

Proposal Basic Information	
Proposal File No	CMC/BP/0171/W07/2023
Owner Name	RAMANUJ PASWAN
Khata No	27,780
Plot No	1983,1986
Village Name	Chas
Use	Residential
SubUse	Bungalow/ Dwelling / Non Apartment

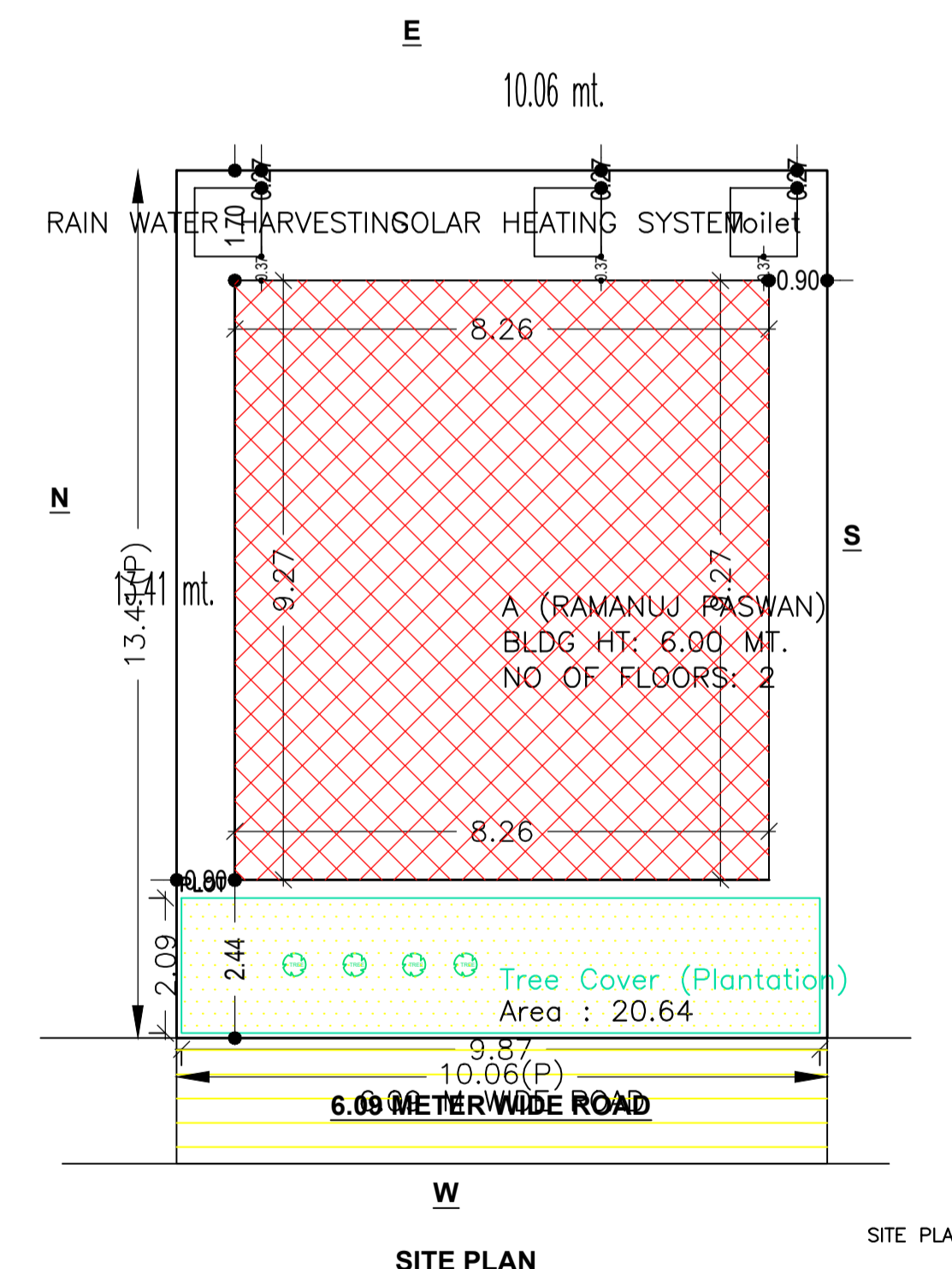
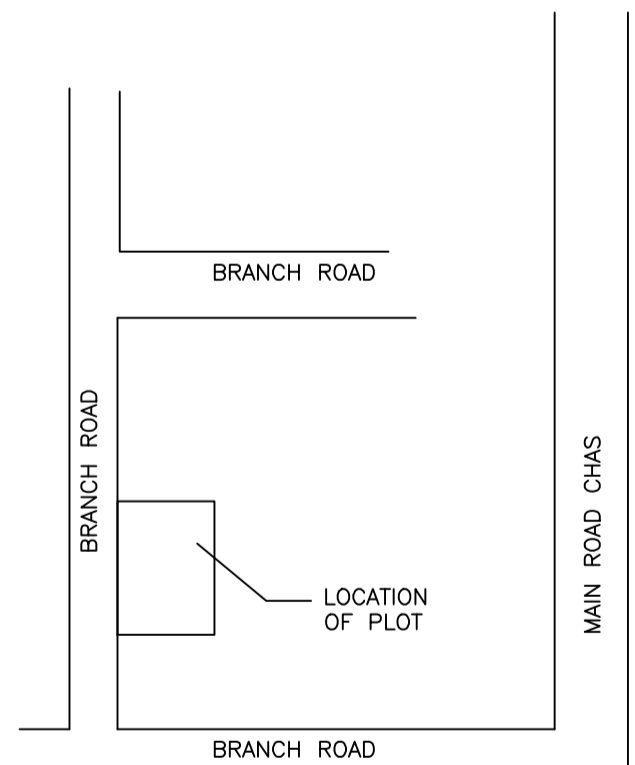
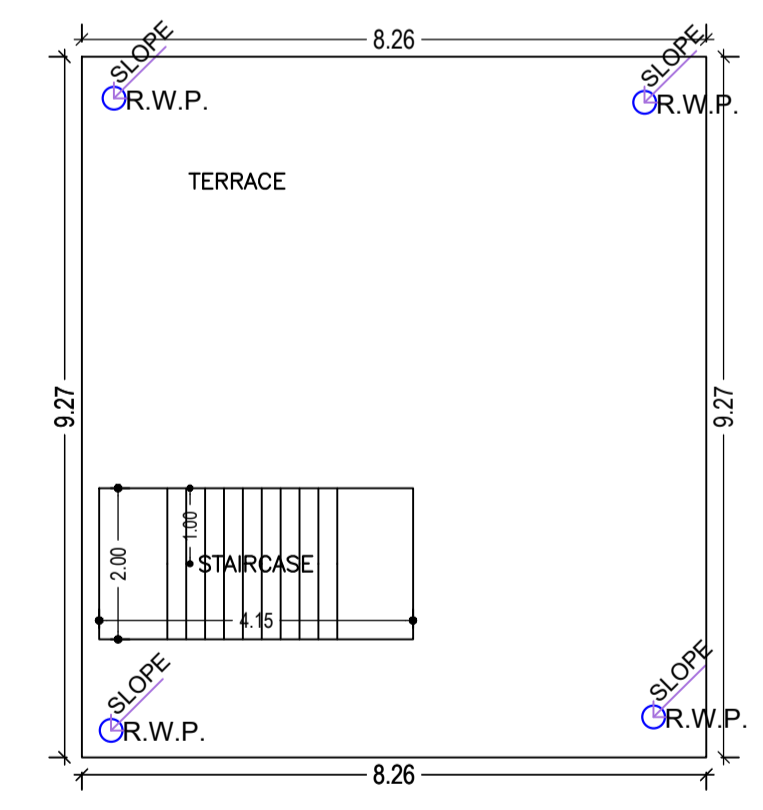
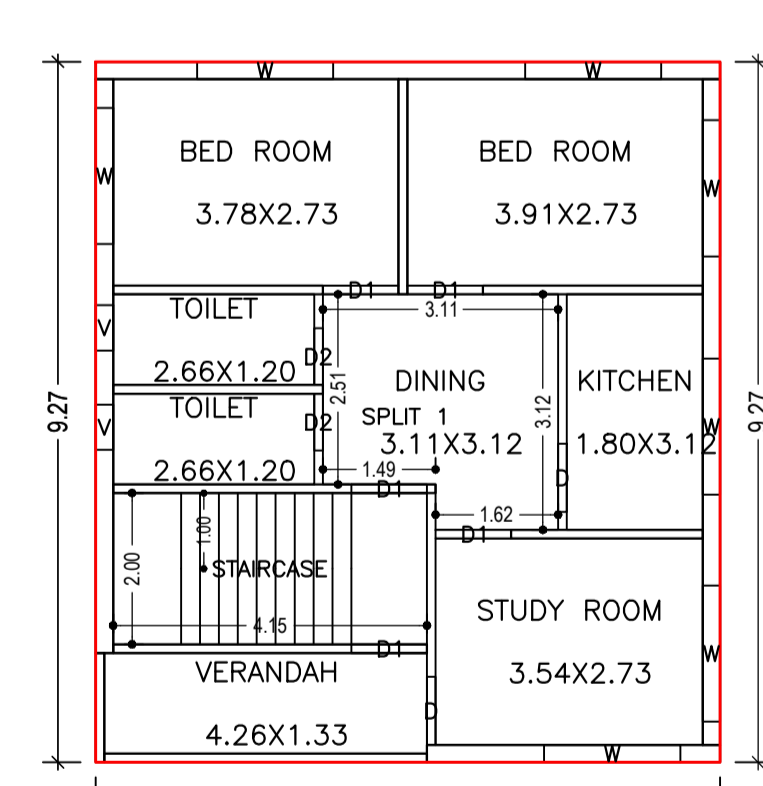
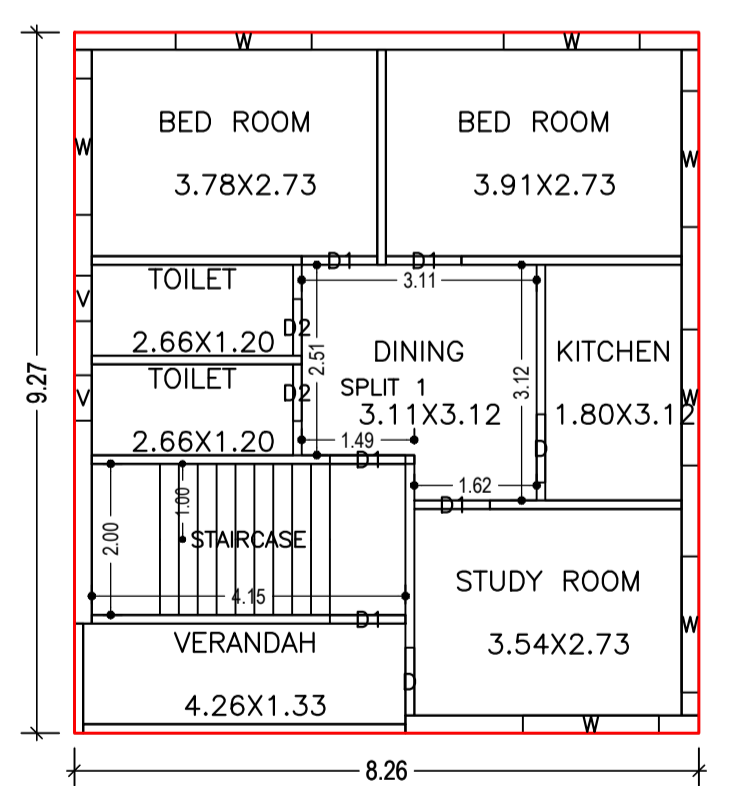
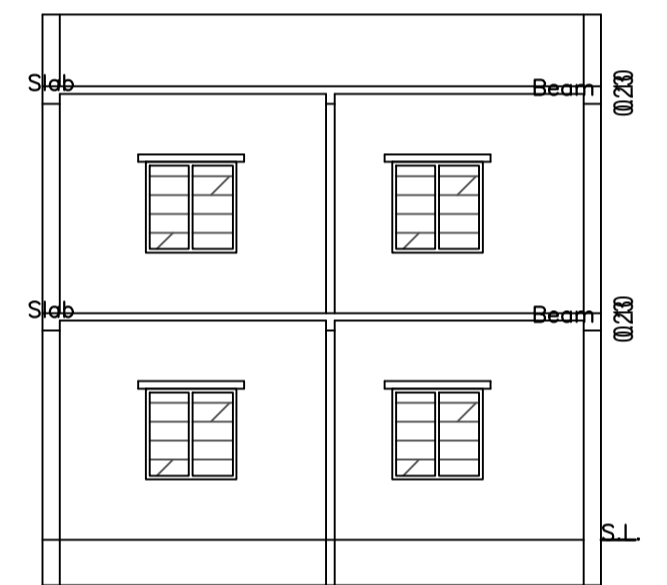
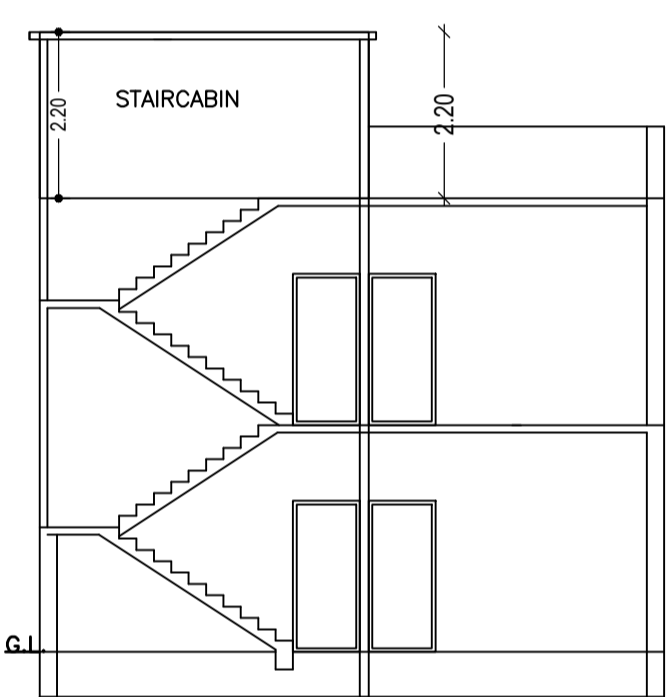
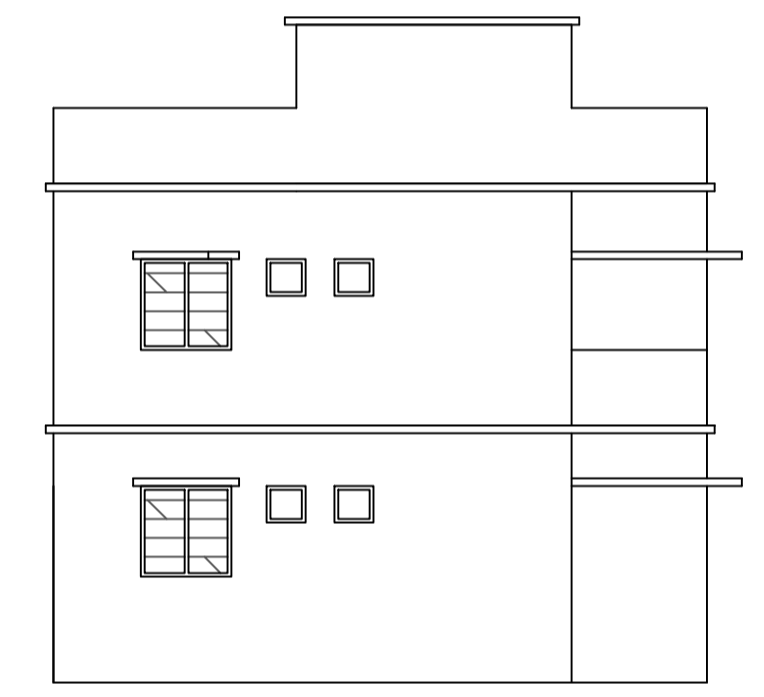
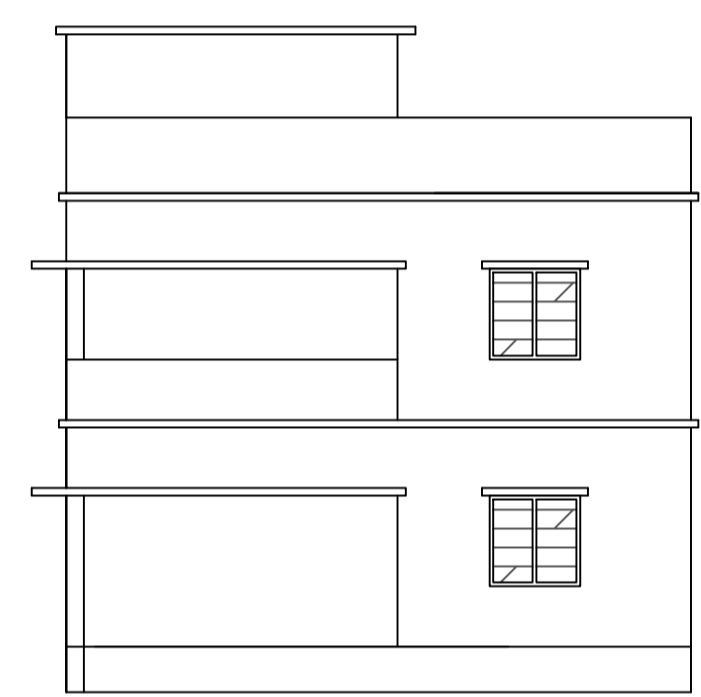
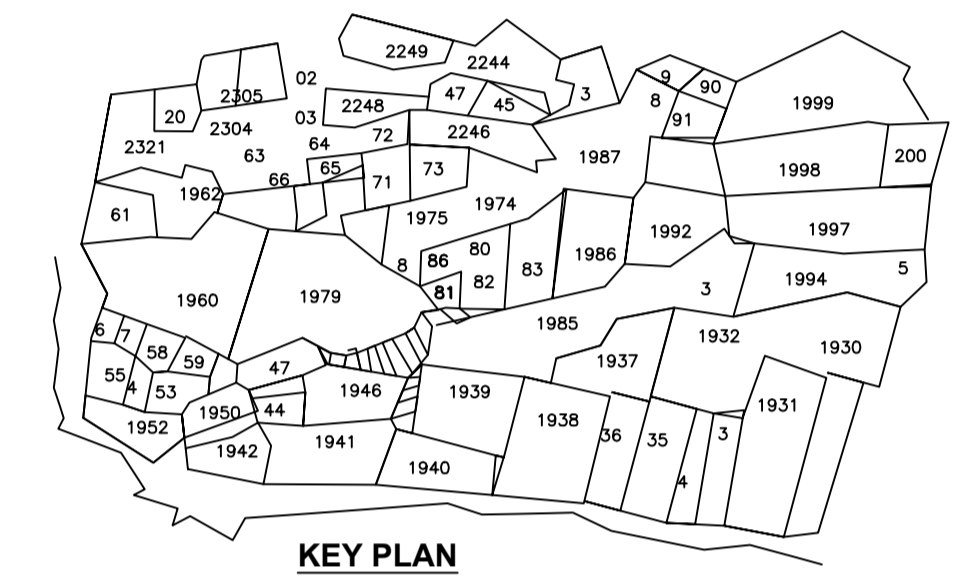
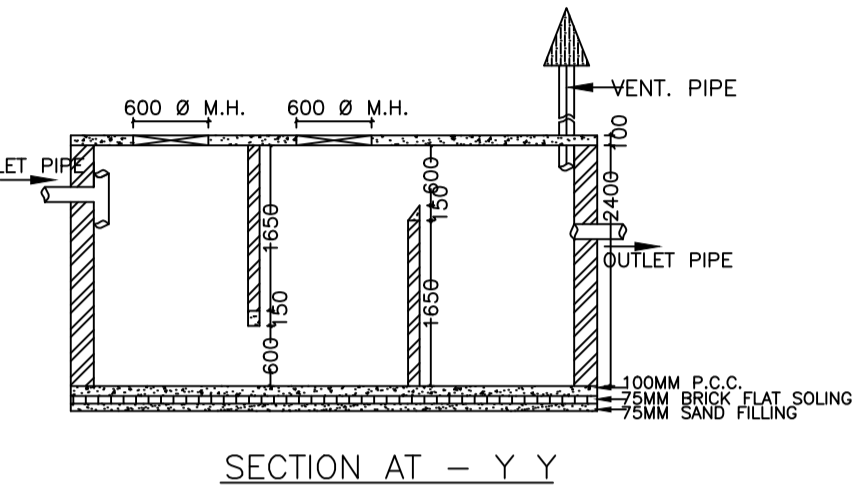
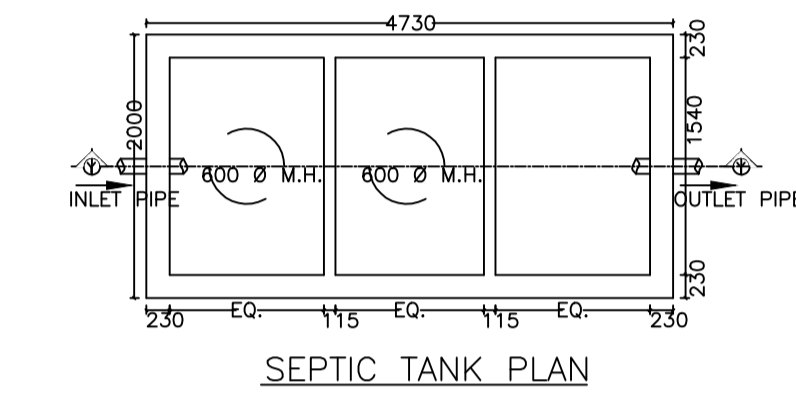
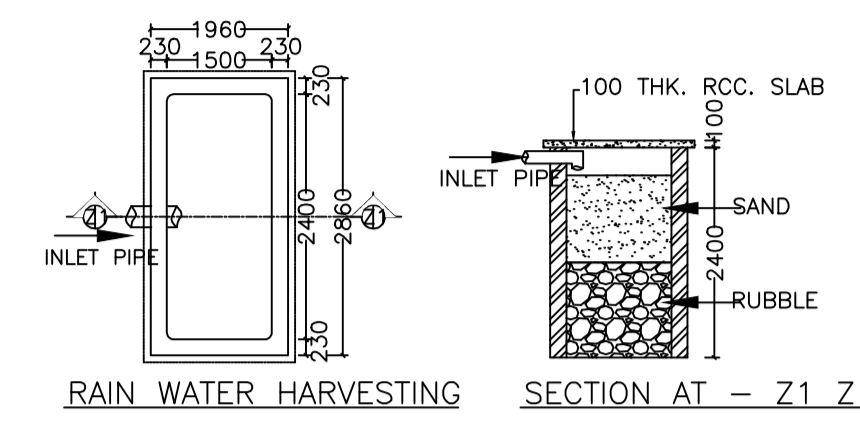
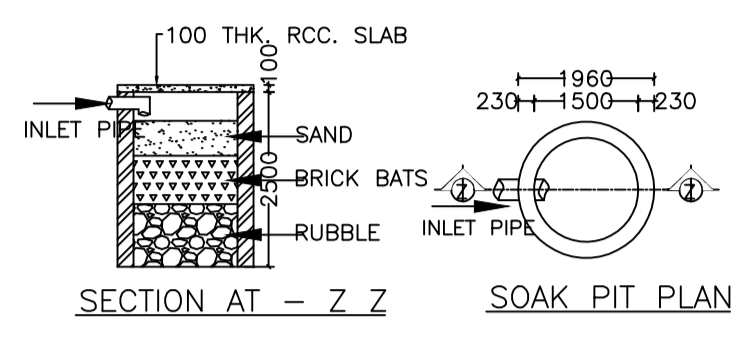
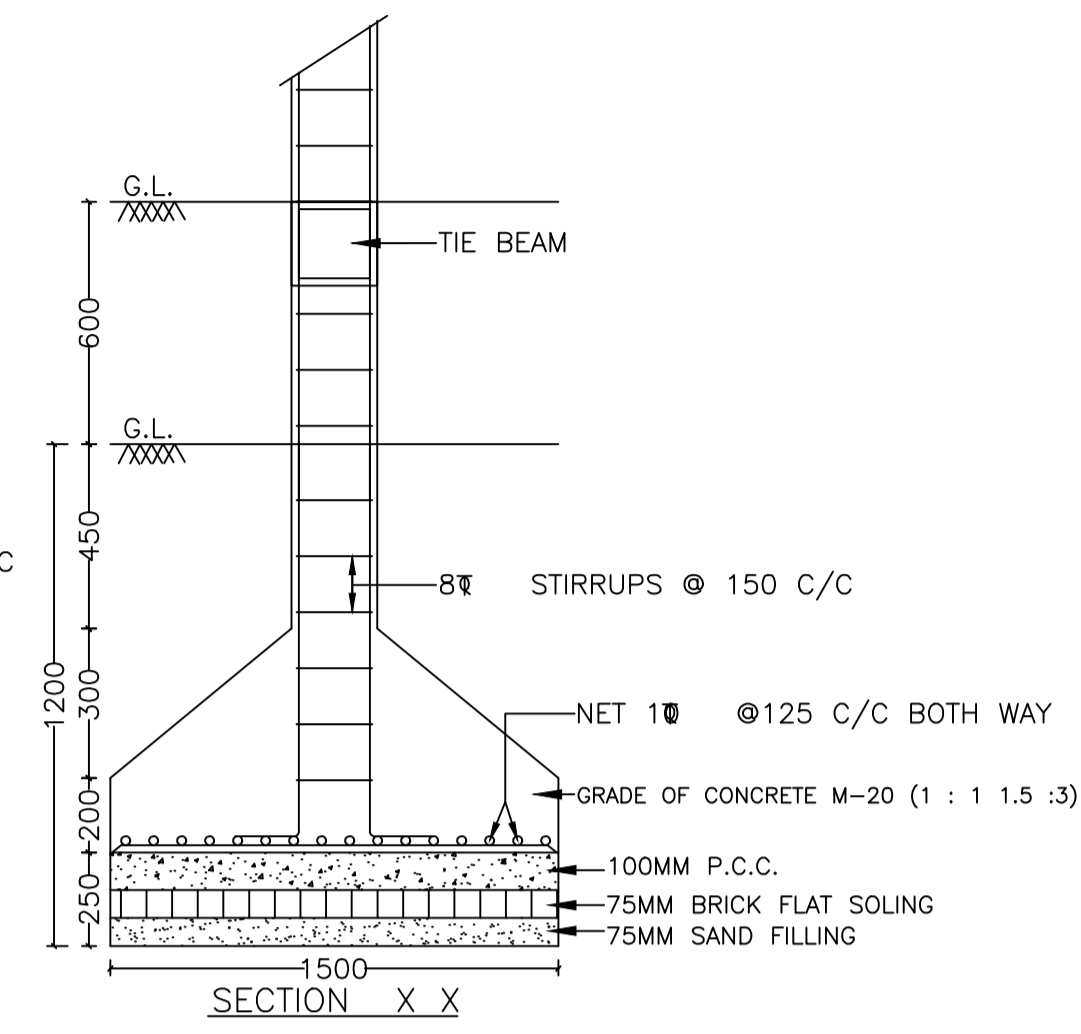
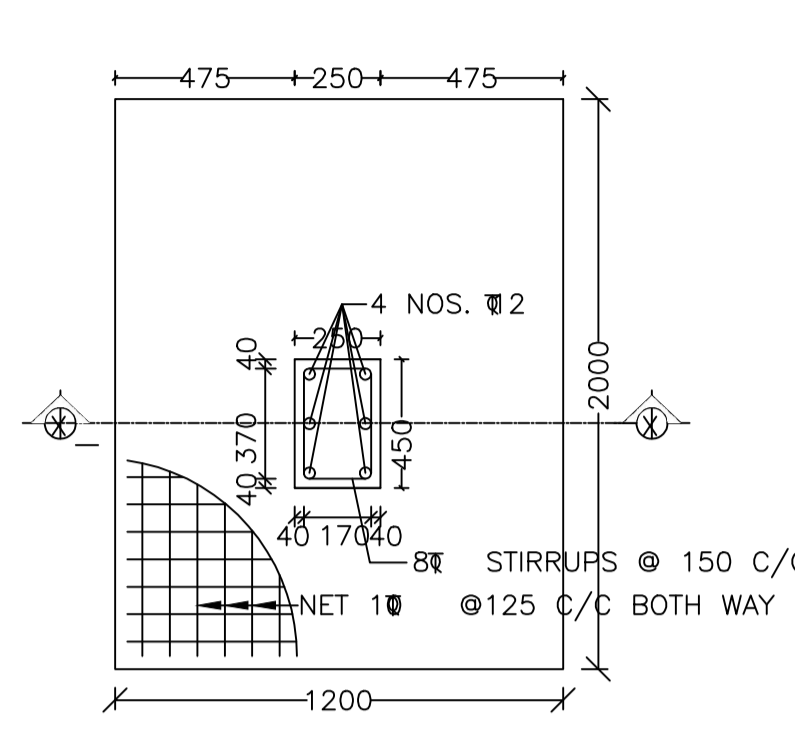

AREA STATEMENT CHAS MUNICIPAL CORPORATION	VERSION NO.: 1.0.66	
	VERSION DATE: 16/10/2020	
PROJECT DETAIL:		
Region: JHARKHAND URBAN LOCAL BODIES	Plot Use: Residential	
District: BOKARO	Plot SubUse: Bungalow/ Dwelling / Non Apartment	
Authority: CHAS MUNICIPAL CORPORATION	Plot/Neary/ReligiousStructure: NA	
Inward No: CMC/BP/0171/W07/2023	Plot/SubPlot No: 1983,1986	
Application Type: General Proposal	North: CTS No. - MEENA DEVI	
Project Type: Building Permission	South: PLOT NO. -DE-4	
Nature of Development: New	East: CTS No. - AJEET KUMAR VERMA	
Location of Development Area: Old Area	West: Road Width - 6.09	
AREA DETAILS:		
AREA OF PLOT (Minimum)	(A)	SQ.MT. 134.90
NET AREA OF PLOT(Gross Plot Area - Deduction from Gross Plot area)	(A-Deductions)	134.90
Deduction for Balance Plot Area(from Gross Plot Area)		
Common Plot		20.64
Total		20.64
BALANCE AREA OF PLOT(Net Plot Area - Recreational/Amenity space)	(A-Deductions)	114.26
PLOT AREA FOR COVERAGE(Net Plot Area)	(A-Deductions)	134.90
Plot Area for FAR (Net Plot Area + RoadWidening Area)	(A-Deductions)	134.90
COVERAGE CHECK		
Permissible Coverage area (70.00 %)		94.43
Proposed Coverage Area (56.73 %)		76.53
Total Prop. Coverage Area (56.73 %)		76.53
Balance coverage area (13.27 %)		17.90
FAR CHECK		
Perm. FAR Area (1,800)		242.82
Total Perm. FAR area		242.82
Residential FAR		153.06
Proposed FAR Area		153.06
Total Proposed FAR Area		153.06
Consumed FAR (Factor)		1.13
Balance FAR Area		89.76
BUILT UP AREA CHECK		
Total Proposed BuiltUp Area		153.06
ARCHITECT (Regd) MANOJ KUMAR		
ENGINEER (Regd)		
SUPERVISOR (Regd)		
OWNER (Regd) RAMANUJ PASWAN		
DEVELOPMENT AUTHORITY LOCAL BODY		

Building :A (RAMANUJ PASWAN)

Floor Name	Total Built Up Area (Sq.mt.)	Proposed FAR Area (Sq.mt.) Resi.	Total FAR Area (Sq.mt.)	Total Consumed Additional FAR Area (Sq.mt.)	Tnmt (No.)
Ground Floor	76.53	76.53	76.53	76.53	01
First Floor	76.53	76.53	76.53	76.53	00
Terrace Floor	0.00	0.00	0.00	0.00	00
Total	153.06	153.06	153.06	153.06	01
Total Number of Same Buildings	1				
Total:	153.06	153.06	153.06	153.06	01

SCHEDULE OF DOOR:

BUILDING NAME	NAME	LENGTH	HEIGHT	NOS
A (RAMANUJ PASWAN)	D2	0.75	2.10	04
A (RAMANUJ PASWAN)	D	0.90	2.10	04
A (RAMANUJ PASWAN)	D1	1.00	2.10	10

SCHEDULE OF WINDOW/VENTILATION:

BUILDING NAME	NAME	LENGTH	HEIGHT	NOS
A (RAMANUJ PASWAN)	V	0.60	1.20	04
A (RAMANUJ PASWAN)	W	1.80	1.20	14

COLOR INDEX

PLOT BOUNDARY	Black
ABUTTING ROAD	Green
PROPOSED CONSTRUCTION	Red
COMMON PLOT	Yellow
ROAD WIDENING AREA	Blue
EXISTING (To be retained)	Blue
EXISTING (To be demolished)	Yellow

Building USE/SUBUSE Details

Building Name	Building Use	Building SubUse	Building Structure
A (RAMANUJ PASWAN)	Residential	Bungalow/ Dwelling / Non Apartment	Non-Highrise

FAR & Tenement Details (Table 4c-1)

Building	No. of Same Bldg	Total Built Up Area (Sq.mt.)	Proposed FAR Area (Sq.mt.) Resi.	Total FAR Area (Sq.mt.)	Total Consumed Additional FAR Area (Sq.mt.)	Tnmt (No.)
A (RAMANUJ PASWAN)	1	153.06	153.06	153.06	153.06	01
Grand Total:	1	153.06	153.06	153.06	153.06	01

UnitBUA Table for Building :A (RAMANUJ PASWAN)

FLOOR	Name	UnitBUA Type	UnitBUA Area	Carpet Area	No. of Rooms	No. of Tenement
GROUND FLOOR PLAN	SPLIT 1	FLAT	120.11	116.93	8	1
FIRST FLOOR PLAN	SPLIT 1	FLAT	0.00	0.00	8	0
Total:	-	-	120.11	116.93	16	1

Buildingwise Floor FAR Details

Floor Name	Building Name A (RAMANUJ PASWAN)		Total	
	Proposed Built Up Area (Sq.mt.)	Proposed FAR Area (Sq.mt.)	Total Proposed Built Up Area (Sq.mt.)	Total FAR Area (Sq.mt.)
Ground Floor	76.53	76.53	76.53	76.53
First Floor	76.53	76.53	76.53	76.53
Terrace Floor	0.00	0.00	0.00	0.00
Total:	153.06	153.06	153.06	153.06

LTP NAME AND SIGNATURE	STRUCTURAL ENG'S NAME AND SIGNATURE	BUILDER NAME AND SIGNATURE	DIGITAL SIGNATURE
MANOJ KUMAR CMC/SUP/0016/2018			