

Proposal Basic Information

Proposal File No.	CMC/BP/0107/W19/2023
Owner Name	SANTOSH KUMAR
Khata No	108
Plot No	5290
Village Name	Chas
Use	Residential
SubUse	Bungalow/ Dwelling / Non Apartment

AREA STATEMENT CHAS MUNICIPAL CORPORATION

VERSION NO.: 1.0.66  
VERSION DATE: 16/10/2020

Region: JHARKHAND URBAN	Plot Use: Residential
LOCAL BODIES	Plot SubUse: Bungalow/ Dwelling / Non Apartment
District: BOKARO	PlotNearbyReligiousStructure: NA
Authority: CHAS MUNICIPAL CORPORATION	PlotSubPlot No: 5290
Inward No: CMC/BP/0107/W19/2023	North: CTS No. - N.P. SINGH & SATYENDRA SINGH
Application Type: General Proposal	South: Road Width - ROAD
Project Type: Building Permission	East: Plot No. - PART PLOT NO- 5290
Nature of Development: Addition or Alteration	West: Road Width - ROAD
Location of Development Area: Old Area	

AREA OF PLOT (Minimum)	(A)	SQ. MT.	211.89
NET AREA OF PLOT (Gross Plot Area - Deduction from Gross Plot area)	(A-Deductions)		211.89
Deduction for Balance Plot Area (from Gross Plot Area)			
Common Plot			24.45
Total			24.45
BALANCE AREA OF PLOT (Net Plot Area - Recreational/Amenity space)	(A-Deductions)		187.44
PLOT AREA FOR COVERAGE (Net Plot Area)	(A-Deductions)		211.89
Plot Area for FAR (Net Plot Area + Road Widening Area)	(A-Deductions)		211.89
COVERAGE CHECK			
Permissible Coverage area (70.00 %)			148.32
Proposed Coverage Area (36.37 %)			77.06
Total Prop. Coverage Area (36.37 %)			77.06
Balance coverage area (33.63 %)			71.26
FAR CHECK			
Perm. FAR Area (1.500)			317.83
Total Perm. FAR area			317.83
Residential FAR			245.99
Proposed FAR Area			245.99
Total Proposed FAR Area			245.99
Consumed FAR (Factor)			1.16
Balance FAR Area			71.84
BUILT UP AREA CHECK			
Total Proposed BuiltUp Area			246.00
ARCHITECT (Regd)	DINABANDHU RAJAK		
ENGINEER (Regd)			
SUPERVISOR (Regd)			
OWNER (Regd)	SANTOSH KUMAR		
DEVELOPMENT AUTHORITY		LOCAL BODY	

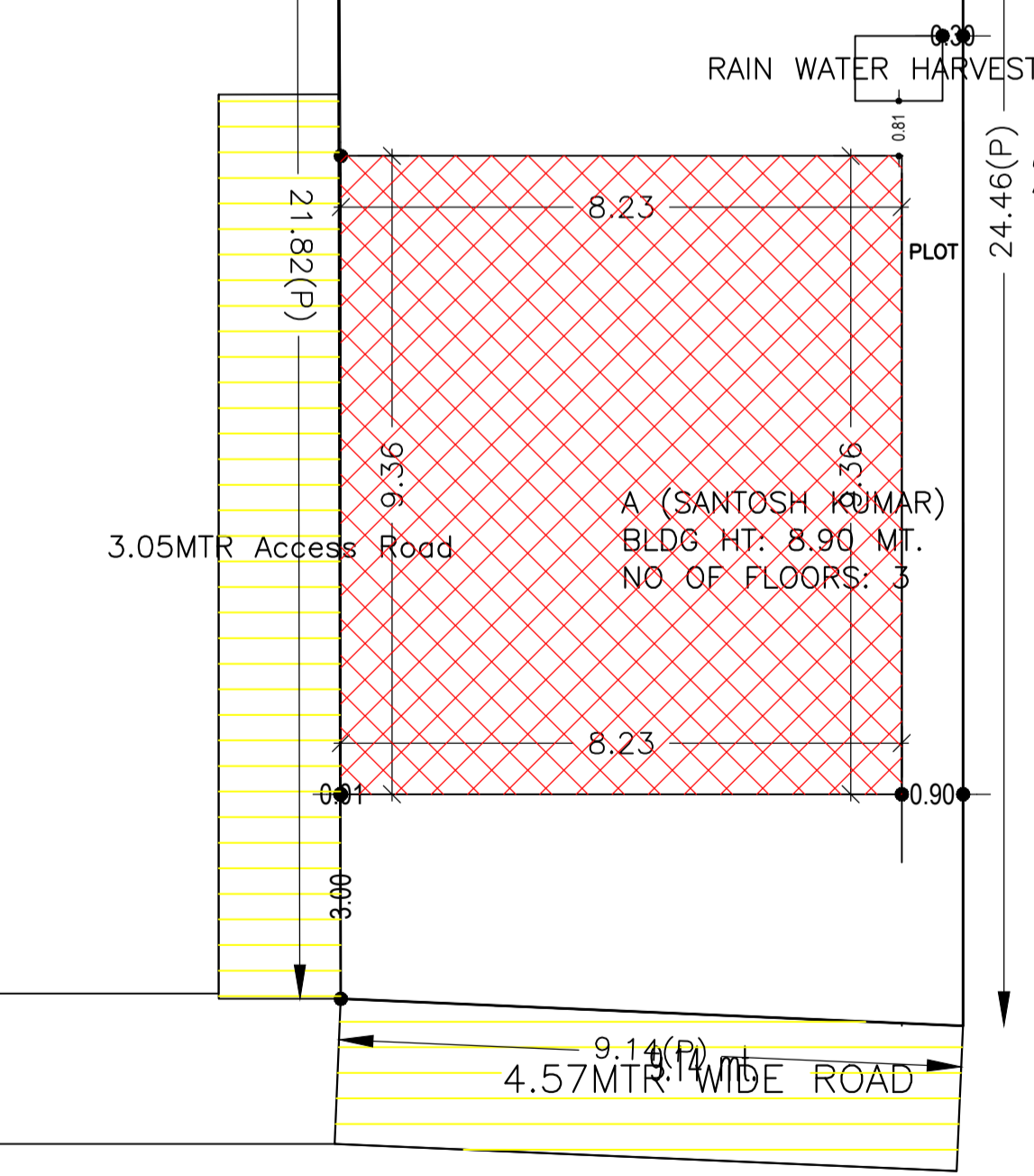
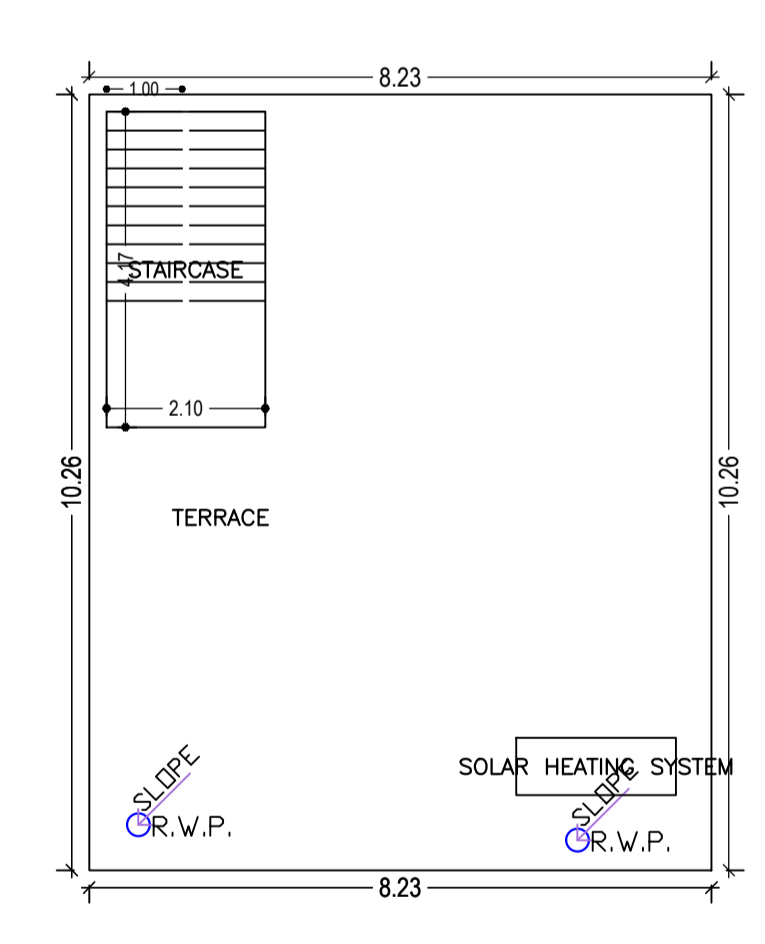
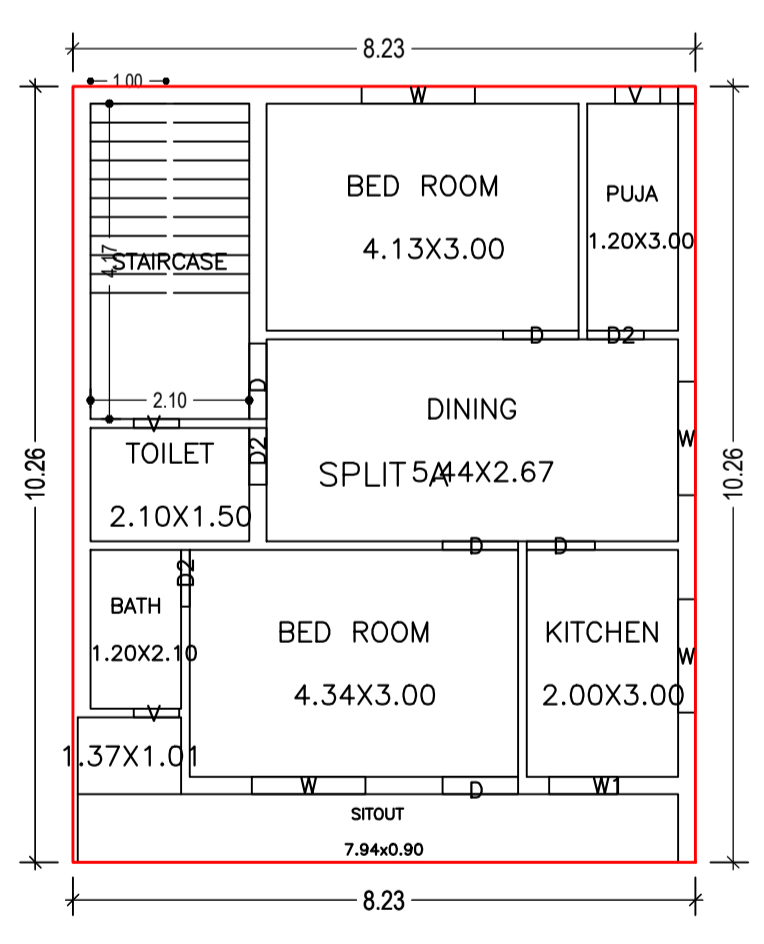
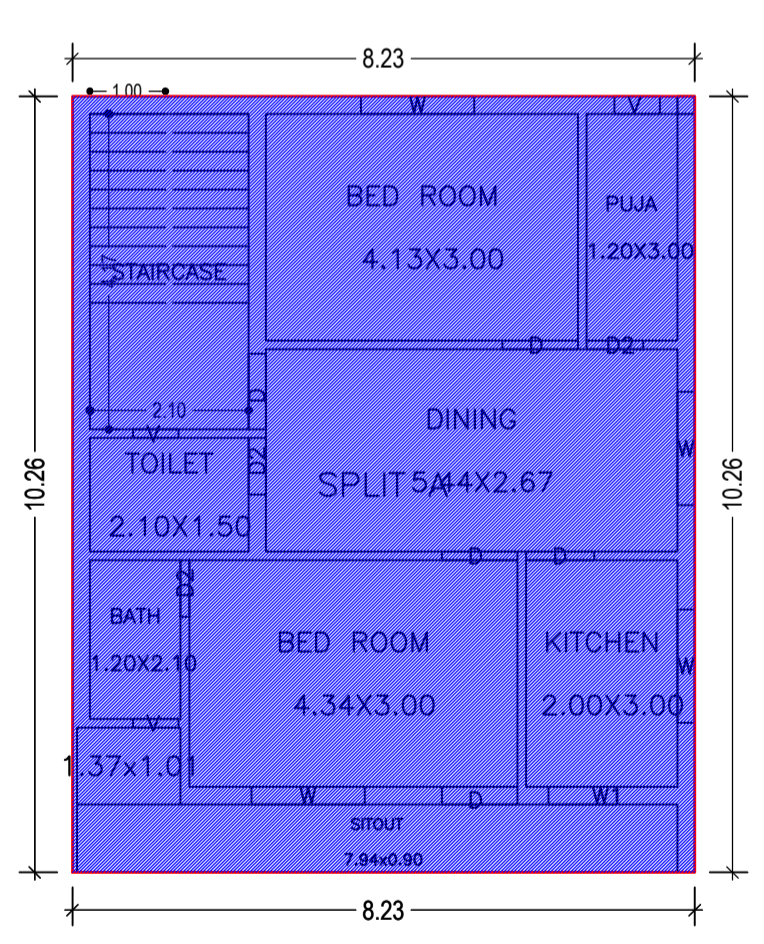
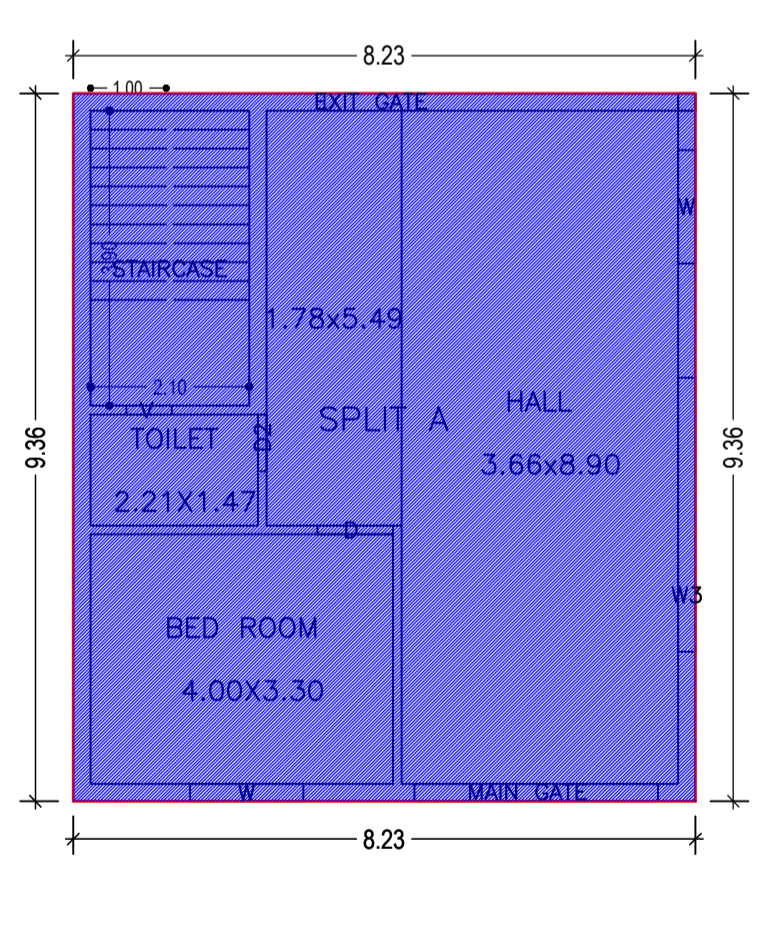
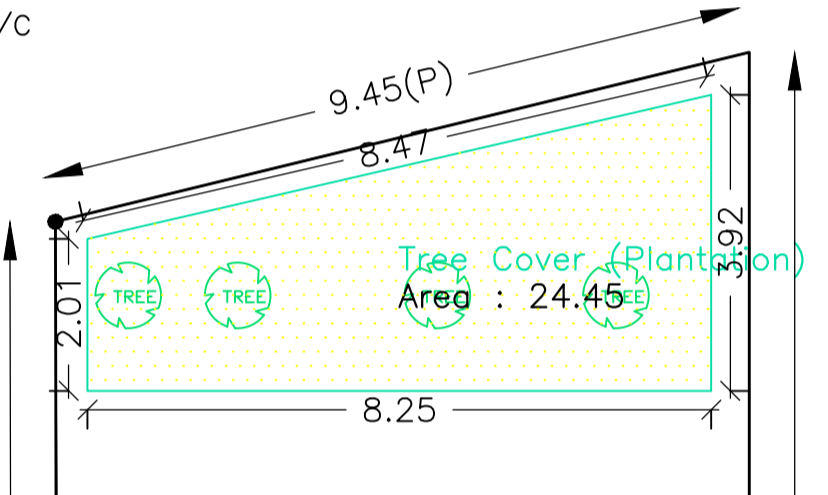
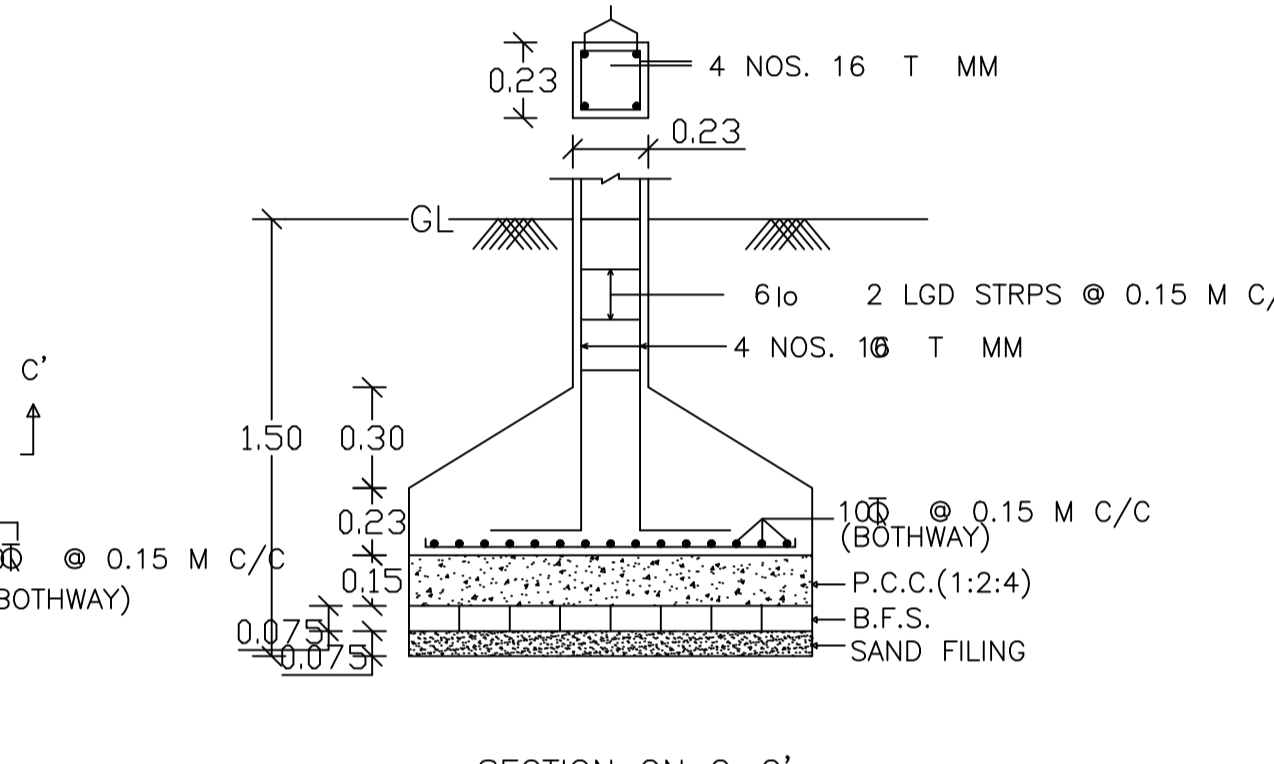
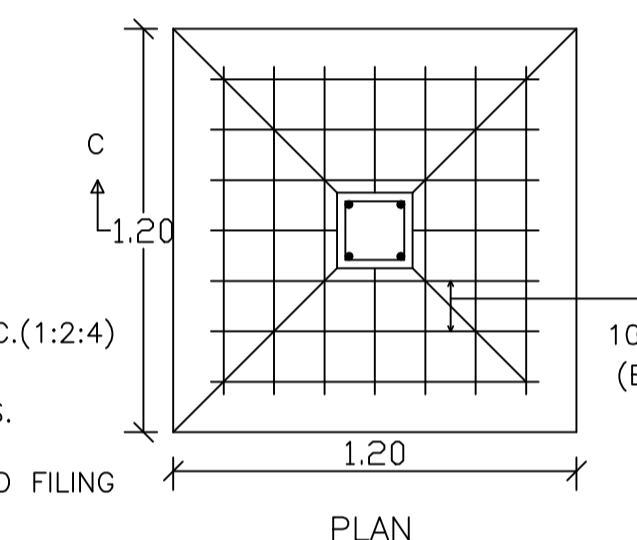
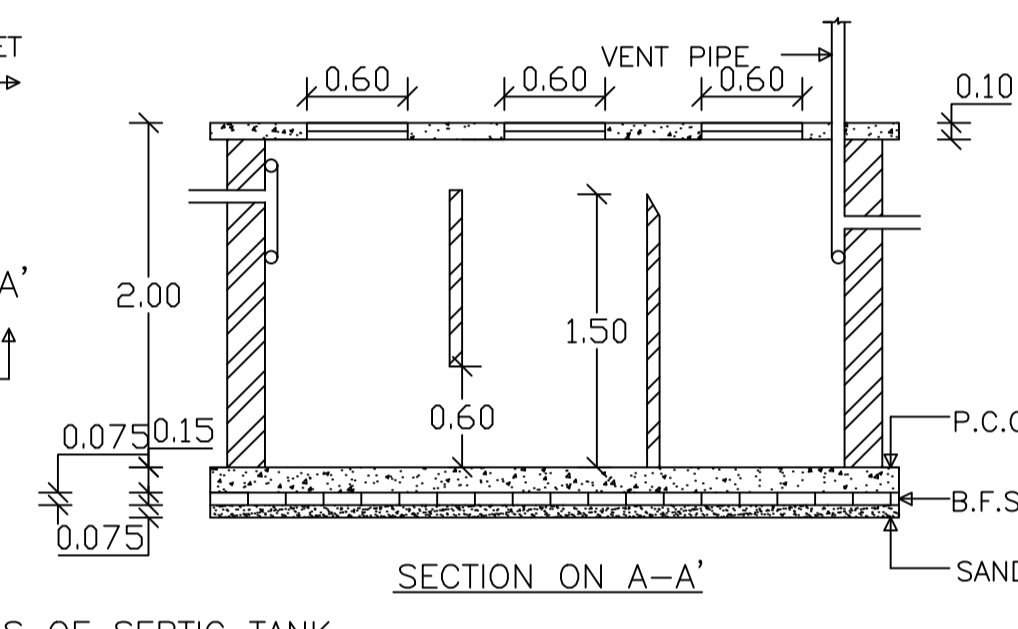
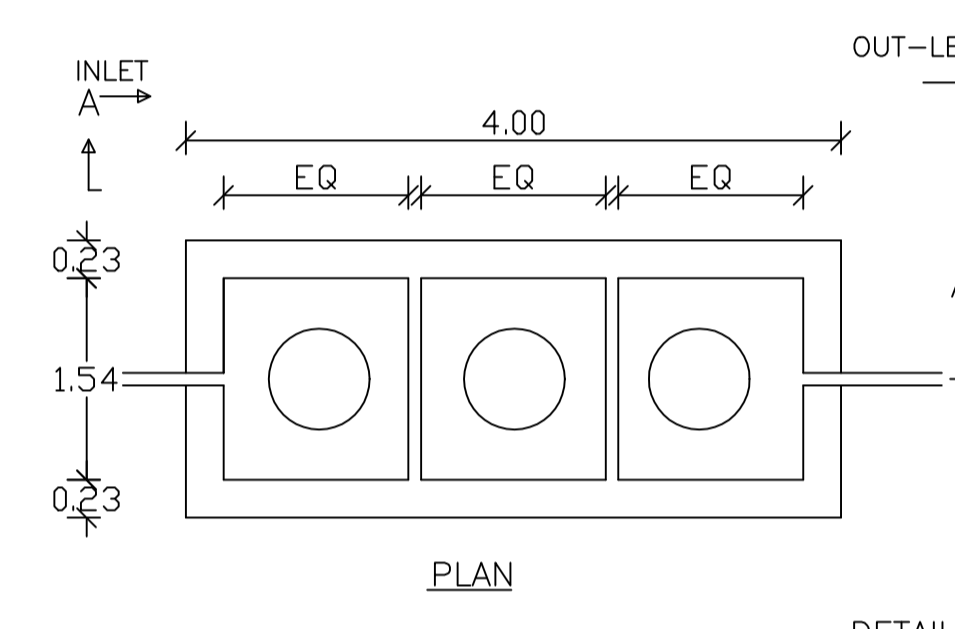

SCHEDULE OF DOOR:

BUILDING NAME	NAME	LENGTH	HEIGHT	NOS
A (SANTOSH KUMAR)	D2	0.75	2.10	07
A (SANTOSH KUMAR)	D	0.90	2.10	02
A (SANTOSH KUMAR)	D	1.00	2.10	09
A (SANTOSH KUMAR)	EXIT GATE	1.22	2.10	01
A (SANTOSH KUMAR)	MAIN GATE	3.22	2.10	01

SCHEDULE OF WINDOW/VENTILATION:

BUILDING NAME	NAME	LENGTH	HEIGHT	NOS
A (SANTOSH KUMAR)	V	0.60	1.20	07
A (SANTOSH KUMAR)	W1	0.90	1.20	02
A (SANTOSH KUMAR)	W	1.50	1.20	10
A (SANTOSH KUMAR)	W3	3.63	1.20	01

Building :A (SANTOSH KUMAR)

Floor Name	Total Built Up Area (Sq.mt.)	Existing Built Up Area (Sq.mt.)	Proposed Built Up Area (Sq.mt.)	Existing FAR Area (Sq.mt.)	Proposed FAR Area (Sq.mt.)	Total FAR Area (Sq.mt.)	Total Consumed Additional FAR Area (Sq.mt.)	Tnmt (No.)
Ground Floor	77.06	77.06	0.00	77.06	0.00	77.06	77.06	01
First Floor	84.47	84.47	0.00	84.47	0.00	84.47	84.47	00
Second Floor	84.47	0.00	84.47	0.00	84.47	84.47	84.47	00
Terrace Floor	0.00	0.00	0.00	0.00	0.00	0.00	0.00	00
Total	246.00	161.53	84.47	161.53	84.47	246.00	246.00	01

Building USE/SUBUSE Details

Building Name	Building Use	Building SubUse	Building Structure
A (SANTOSH KUMAR)	Residential	Bungalow/ Dwelling / Non Apartment	Non-Highrise Building

FAR & Tenement Details (Table 4c-1)

Building	No. of Same Bldg	Total Built Up Area (Sq.mt.)	Existing Built Up Area (Sq.mt.)	Proposed Built Up Area (Sq.mt.)	Existing FAR Area (Sq.mt.)	Proposed FAR Area (Sq.mt.)	Total FAR Area (Sq.mt.)	Total Consumed Additional FAR Area (Sq.mt.)	Tnmt (No.)
A (SANTOSH KUMAR)	1	246.00	161.53	84.47	161.53	84.47	246.00	246.00	01
Grand Total	1	246.00	161.53	84.47	161.53	84.47	246.00	246.00	01

UnitBUA Table for Building :A (SANTOSH KUMAR)

Floor Name	Existing Built Up Area (Sq.mt.)	Proposed Built Up Area (Sq.mt.)	Existing FAR Area (Sq.mt.)	Proposed FAR Area (Sq.mt.)	Total Existing Built Up Area (Sq.mt.)	Total Proposed Built Up Area (Sq.mt.)	Total Existing FAR Area (Sq.mt.)	Total Proposed FAR Area (Sq.mt.)
Ground Floor	77.06	77.06	77.06	0.00	77.06	77.06	77.06	77.06
First Floor	84.47	84.47	84.47	0.00	84.47	84.47	84.47	84.47
Second Floor	84.47	84.47	84.47	0.00	84.47	84.47	84.47	84.47
Terrace Floor	0.00	0.00	0.00	0.00	0.00	0.00	0.00	0.00
Total	246.00	246.00	246.00	0.00	246.00	246.00	246.00	246.00

FLOOR	Name	UnitBUA Type	Entity Type	UnitBUA Area	Carpent Area	No. of Rooms	No. of Tenement
GROUND FLOOR PLAN	SPLIT A	FLAT	Existing	245.99	245.83	3	1
FIRST FLOOR PLAN	SPLIT A	FLAT	Existing	0.00	0.00	8	0
SECOND FLOOR PLAN	SPLIT A	FLAT	Proposed	0.00	0.00	8	0
Total	-	-	-	245.99	245.83	19	1

COLOR INDEX

PLOT BOUNDARY	Black
ABUTTING ROAD	Red
PROPOSED CONSTRUCTION	Green
COMMON PLOT	Blue
ROAD WIDENING AREA	Yellow
EXISTING (To be retained)	Orange
EXISTING (To be demolished)	Purple

LTP NAME AND SIGNATURE

DINABANDHU RAJAK  
CMC/ENG/001/2020

STRUCTURAL ENG'S NAME AND SIGNATURE

BUILDER NAME AND SIGNATURE

DIGITAL SIGNATURE