

Project Title :SRI DHANANJAY PRAMANIK

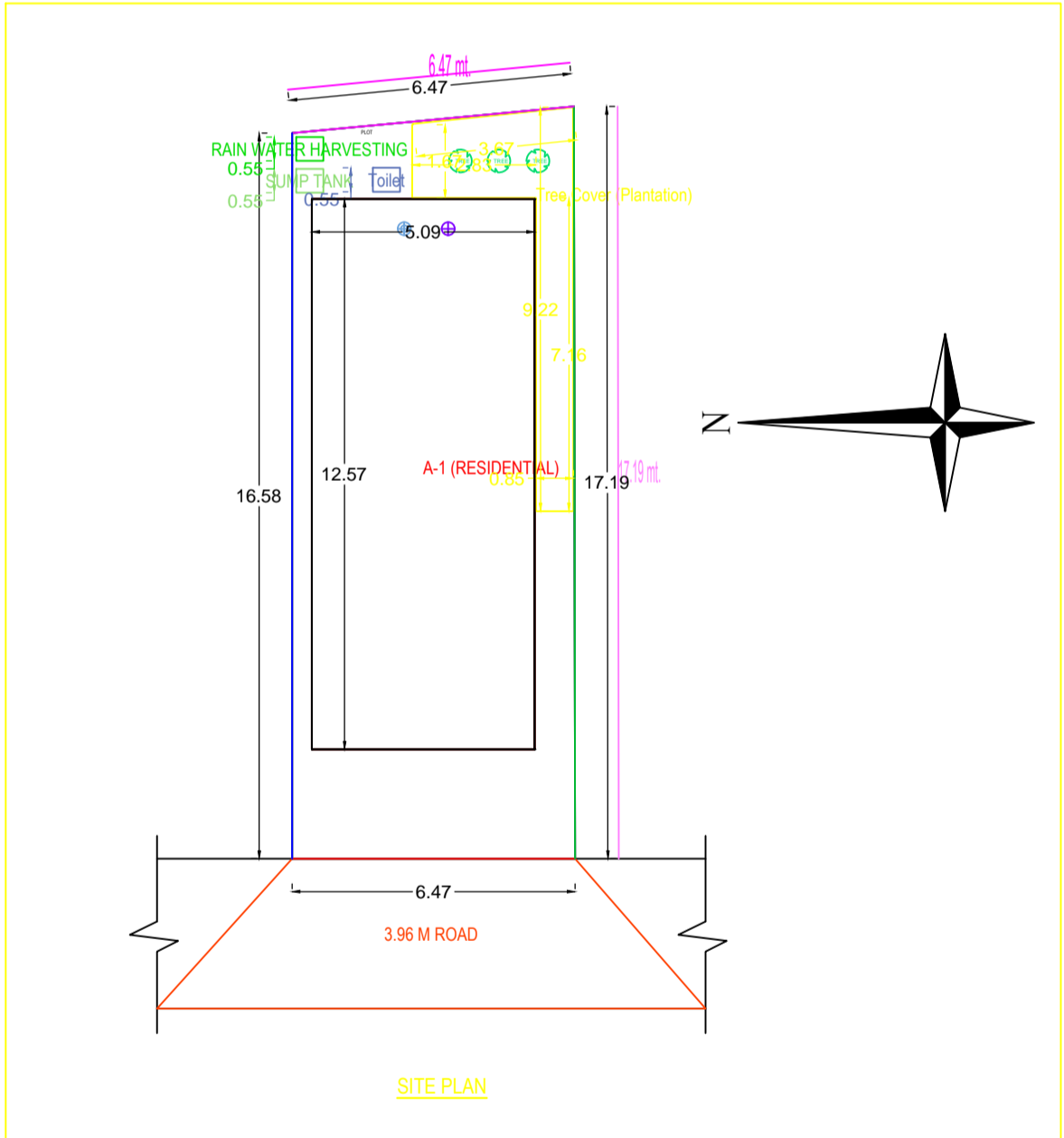
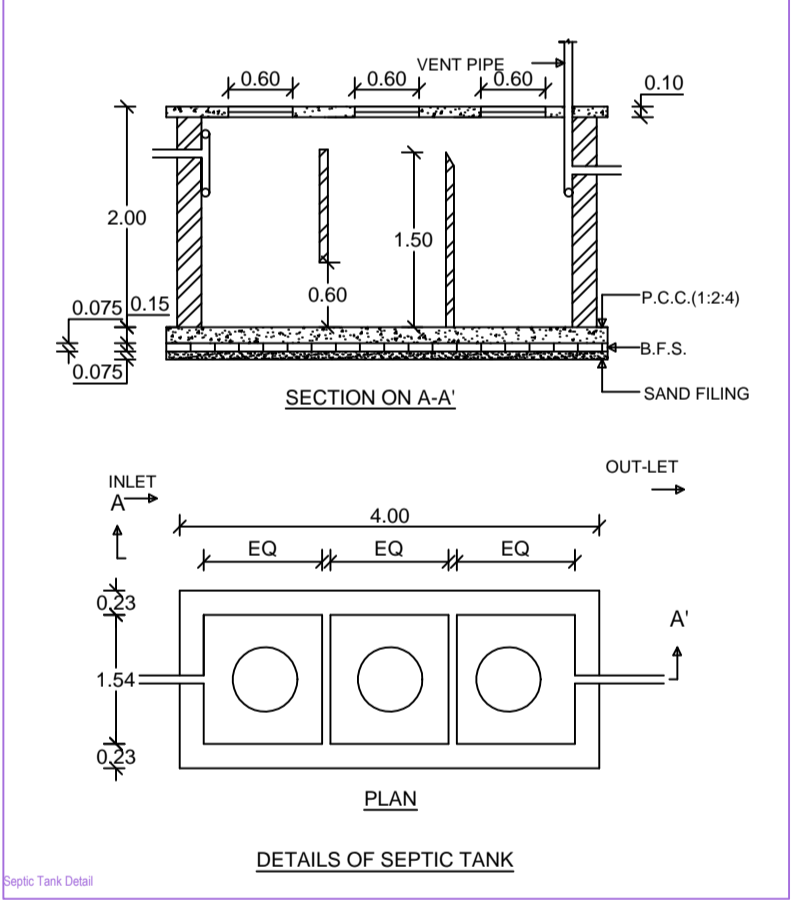
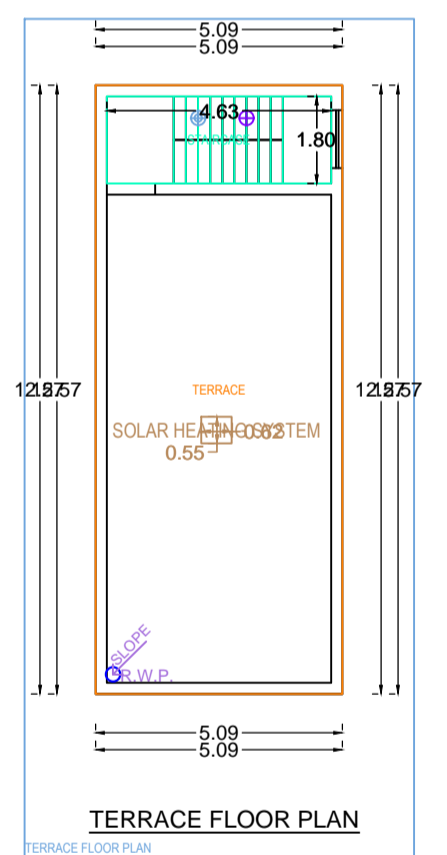
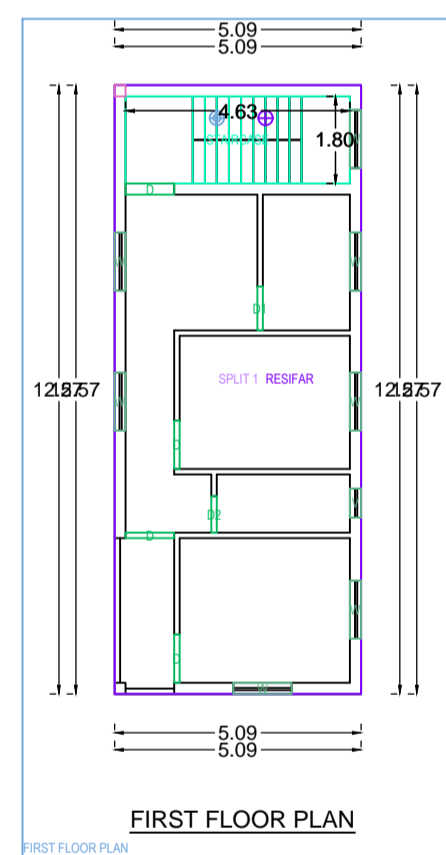
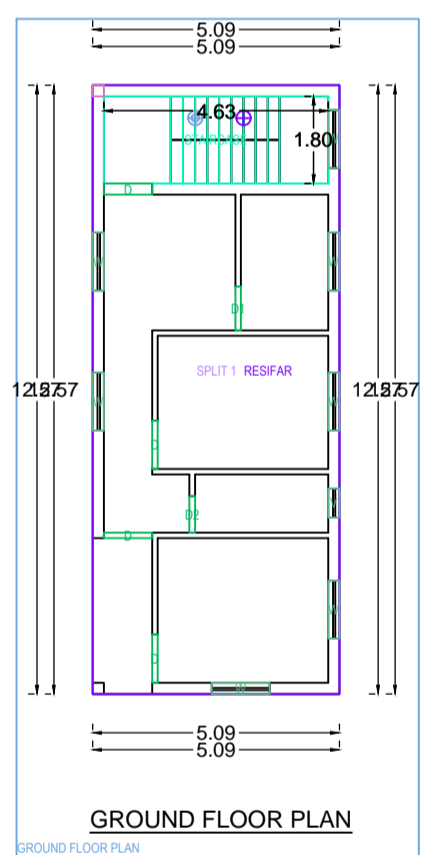
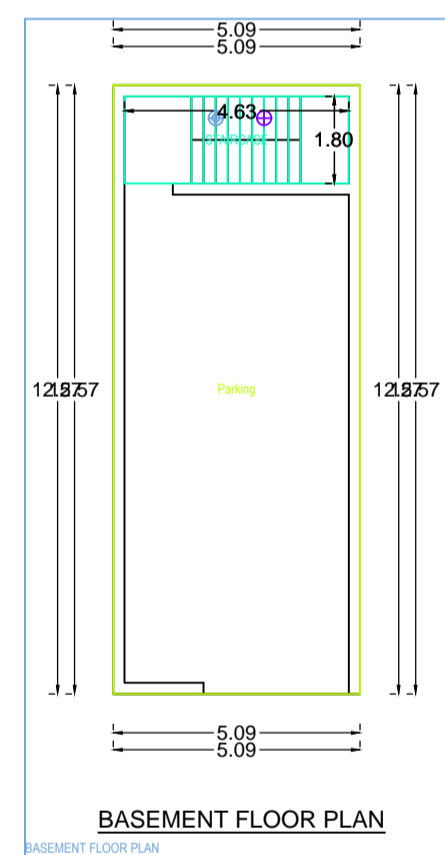
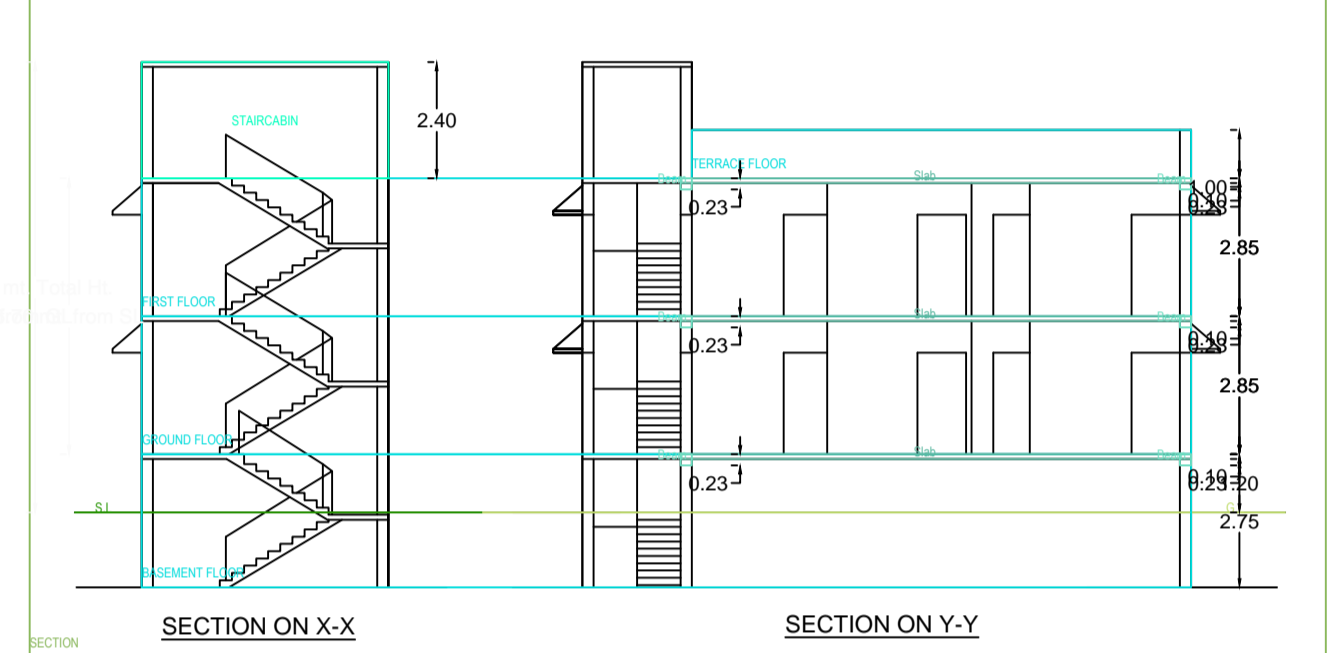
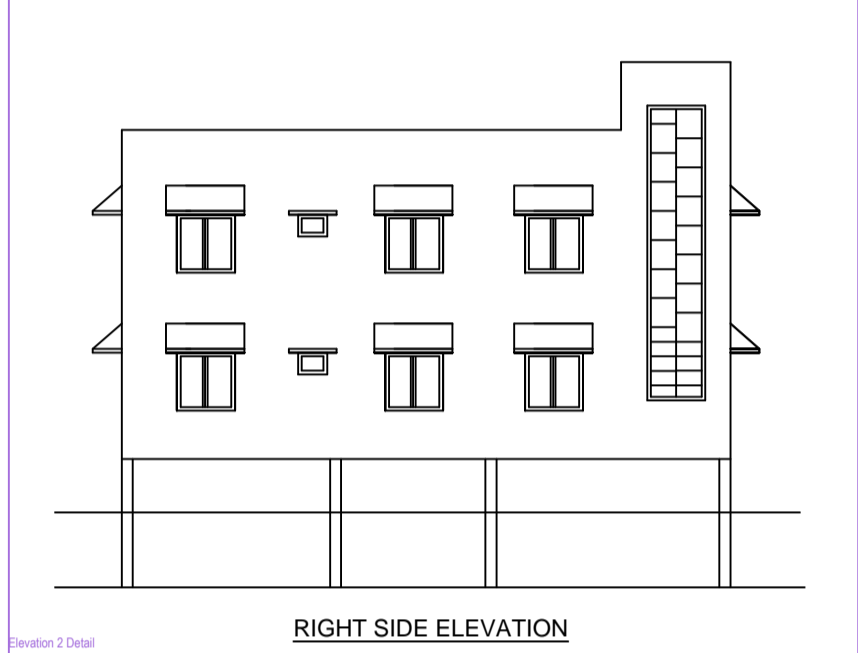
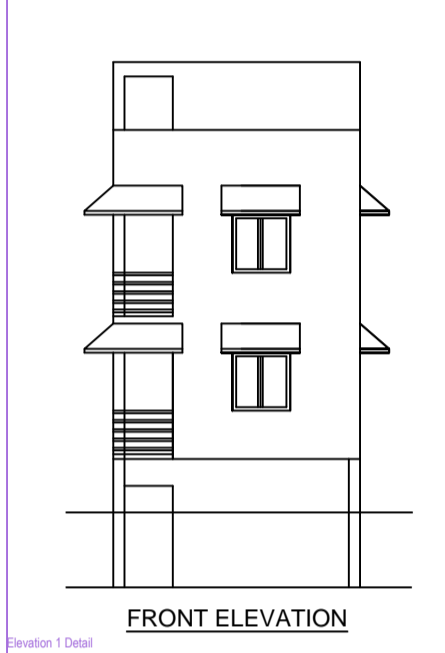
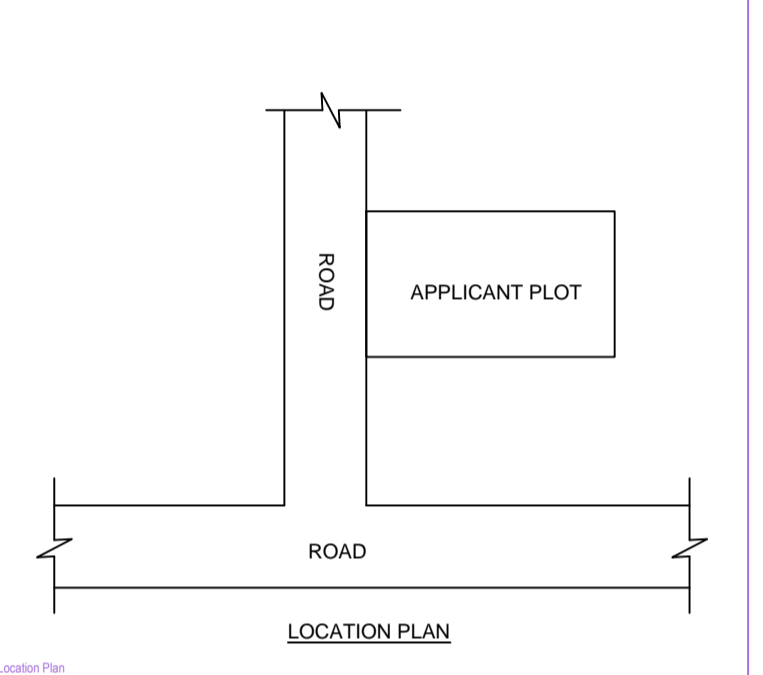
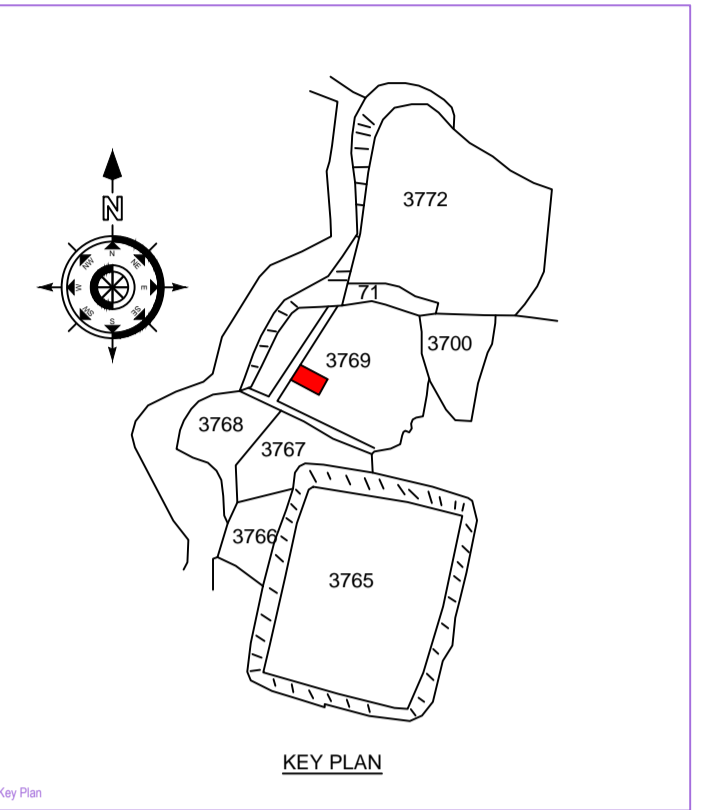
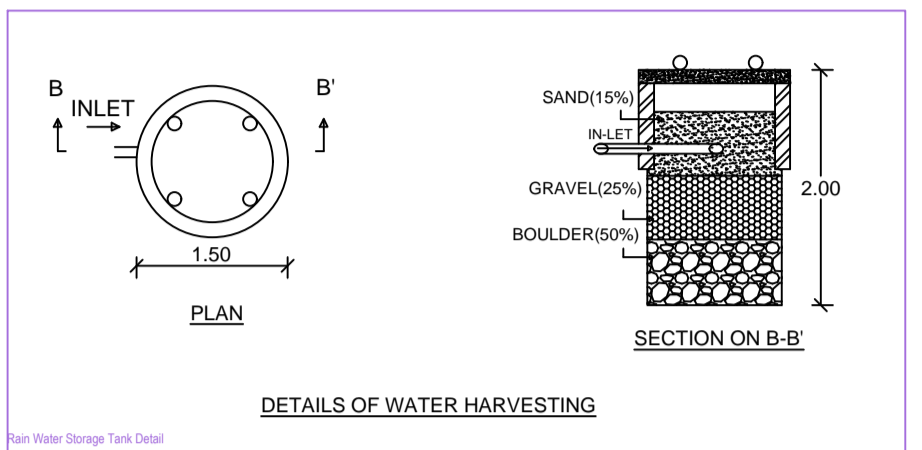
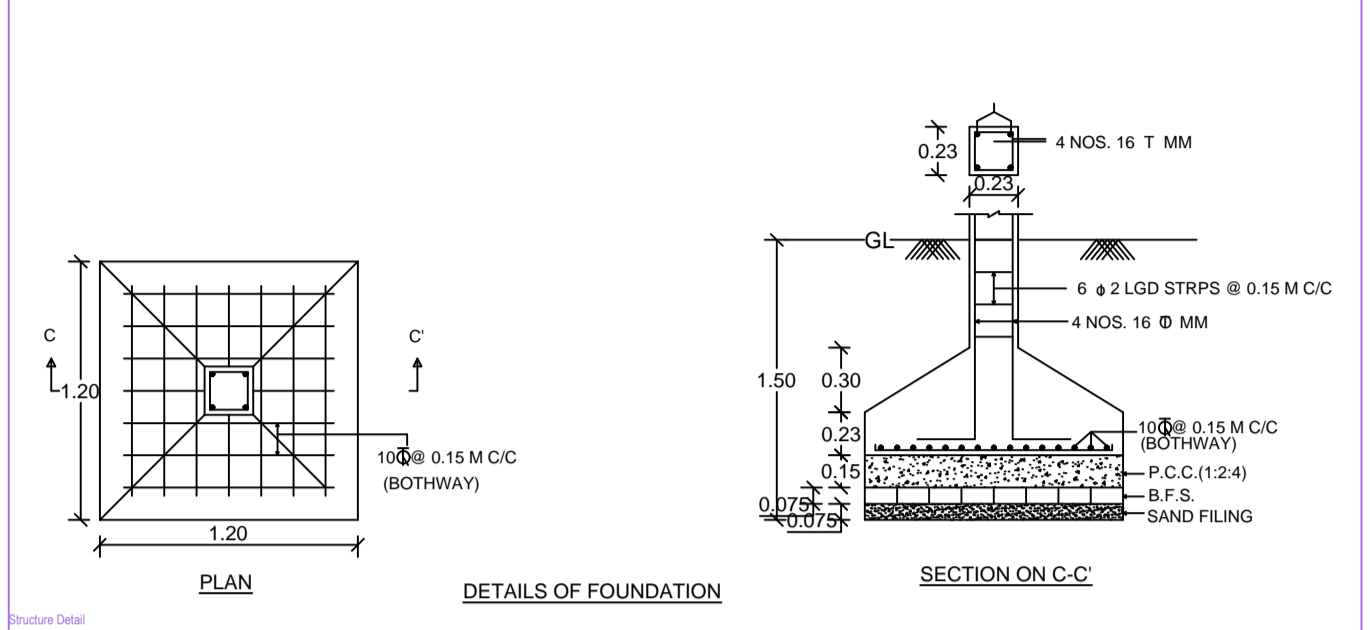

AREA STATEMENT CHAS MUNICIPAL CORPORATION	VERSION NO: 1.0.38
PROJECT DETAIL:	VERSION DATE: 16/10/2020
Plot No. - Residential	Plot Use - Residential
Region - PRAKASHAN URBAN LOCAL BODIES	Plot Sub Use - Singlestorey Dwelling / Non Apartment
District - BOKARO	Land Use Zone - N/A
Application Type - General Proposal	Abutting Road Width -
Project Type - Building Permission	Plot No.
Nature of Development - New	Revenue Survey No/Survey No -
Location - Old Area	Thana No. -
Sub Location - NA	Plotting No. -
Village/Mauza Name -	Khasra No. -
Ward No. -	North -
Road/Street -	South -
	East -
	West -

AREA DETAILS:		SQ.MT
AREA OF PLOT (Minimum)	(A)	108.99
Net Plot Area (Gross Plot Area - Deductions)		108.99
Deductions for Balance Plot Area (from Gross Plot Area)		
- C.P. Area		13.00
- Road		13.00
Balance Plot Area (Net Plot Area - Recreational/Amenity space)	(A-Deductions)	95.99
Plot Area for Coverage (Net Plot Area)	(A-Deductions)	108.99
Plot Area for FSI (Net Plot Area + Road/Widening Area)	(A-Deductions)	108.99
Accessory/Use Area		0.34

COVERAGE CHECK:		
Proposed Coverage Area (88.75%)		64.04
Total Coverage Area (88.75%)		64.04
FAR CHECK:		
Proposed Area of FAR		136.42
Total Area of FAR		136.42

DEVELOPMENT AUTHORITY	LOCAL BODY
-----------------------	------------

COLOR INDEX			
ABUTTING ROAD			
PROPOSED WORK (COVERAGE AREA)			
EXISTING (To be retained)			
EXISTING (To be demolished)			

PARKING CALCULATION:		
Parking Type	Prop. No.	Prop. Area
Other Parking	1	55.70
Total Area	1	55.70

MARGIN DETAIL:					
Building / Wing Name	Road Name	Front Margin	Rear Margin	Side1 Margin	Side2 Margin
A (RESIDENTIAL)	3.96 M ROAD	2.90	1.54	0.45	0.90

BASEMENT MARGIN DETAIL:					
Building / Wing Name	Road Name	Front Margin	Rear Margin	Side1 Margin	Side2 Margin
A (RESIDENTIAL)	3.96 M ROAD	2.90	1.54	0.45	0.90

FAR & Tenement Details (Table 4c-1)							
Building	No. of Same Bldg	Total Built Up Area (Sq.mt)	Deductions (Area in Sq.mt)	Proposed FAR Area (Sq.mt)	Add Area In FAR (Sq.mt)	Total FAR Area (Sq.mt)	Tenr (No.)
A (RESIDENTIAL)	1	192.12	55.70	128.08	8.34	136.42	01
Grand Total:	1	192.12	55.70	128.08	8.34	136.42	01

A (RESIDENTIAL)

Building A (RESIDENTIAL)						
Floor Name	Total Built Up Area (Sq.mt)	Deductions (Area in Sq.mt)	Proposed FAR Area (Sq.mt)	Add Area In FAR (Sq.mt)	Total FAR Area (Sq.mt)	Tenr (No.)
Basement	64.04	55.70	0.00	8.34	8.34	00
Ground Floor	64.04	0.00	64.04	0.00	64.04	01
First Floor	64.04	0.00	64.04	0.00	64.04	00
Terrace Floor	0.00	0.00	0.00	0.00	0.00	00
Total	192.12	55.70	128.08	8.34	136.42	01
Total Number of Same Buildings	1					
Total	192.12	55.70	128.08	8.34	136.42	01

SCHEDULE OF JOINERY:				
BUILDING NAME	NAME	LENGTH	HEIGHT	NOS
A (RESIDENTIAL)	D	2.10	2.10	02
A (RESIDENTIAL)	D1	0.90	2.10	02
A (RESIDENTIAL)	D	1.00	2.10	08
Total				12

SCHEDULE OF JOINERY:				
BUILDING NAME	NAME	LENGTH	HEIGHT	NOS
A (RESIDENTIAL)	V	0.60	1.00	02
A (RESIDENTIAL)	W	1.20	1.20	14
Total				16

UnitBUA Table for Building A (RESIDENTIAL)					
FLOOR	Name	UnitBUA Type	UnitBUA Area	Cost/Plot Area	No. of Tenement
GROUND FLOOR PLAN	SPLIT 1	FLAT	99.06	127.96	1
Total			128.08	127.96	16