

Proposal Basic Information	
Proposal File No.	CMC/BP/0293/W02/2023
Owner Name	1. SMT GITA DEVI 2. SRI. ASHOK KUMAR SHUBHAM DEVELOPER NINETY NINE BUILDERS PVT. LTD. BY ITS DIRECTOR RAM PRATAP SINGH
Khata No	KHATA NO-188
Plot No	PLOT NO-901, 902, 903 & 904
Village Name	Chas
Use	Residential
SubUse	Residential Bldg/Apartment

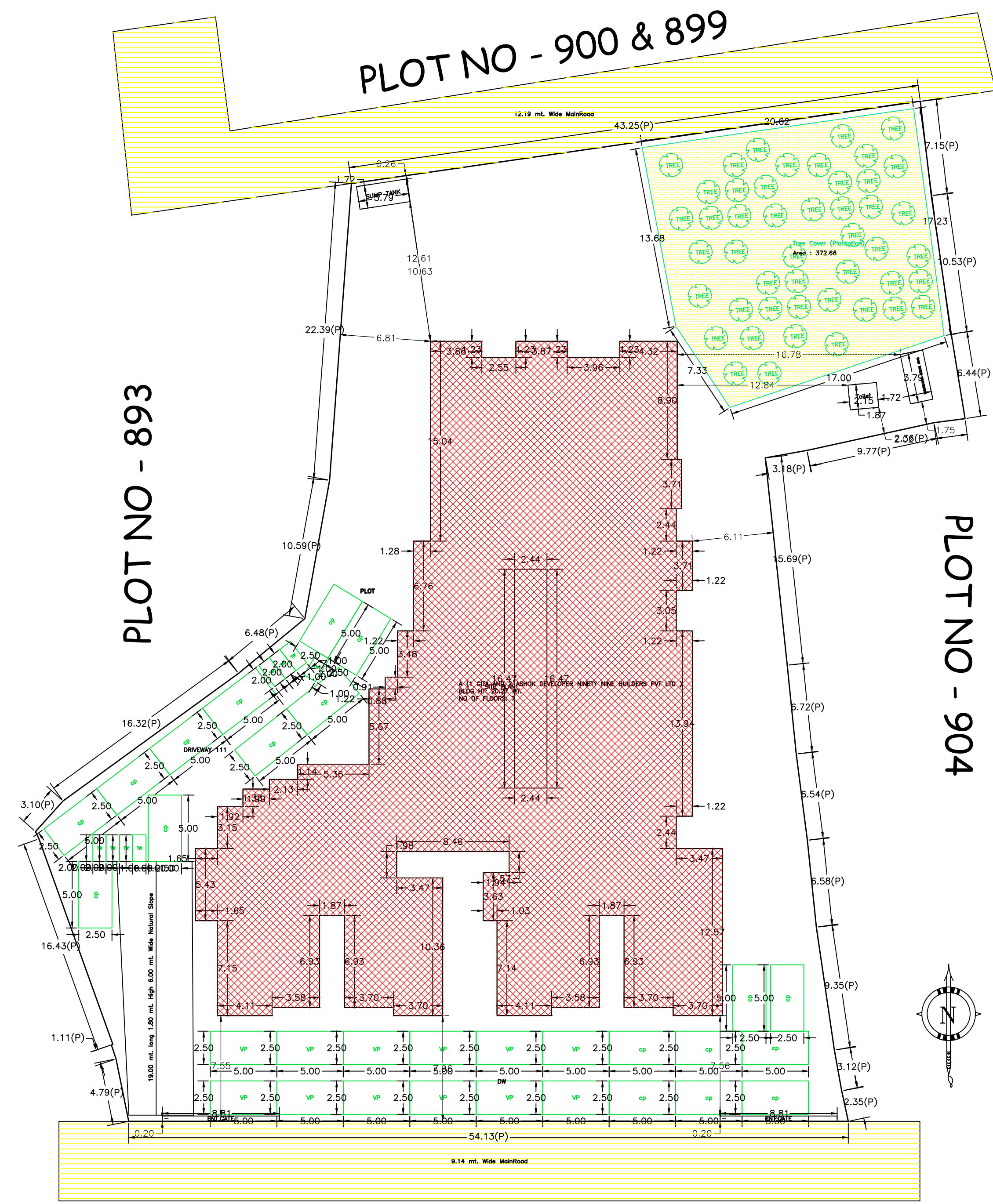
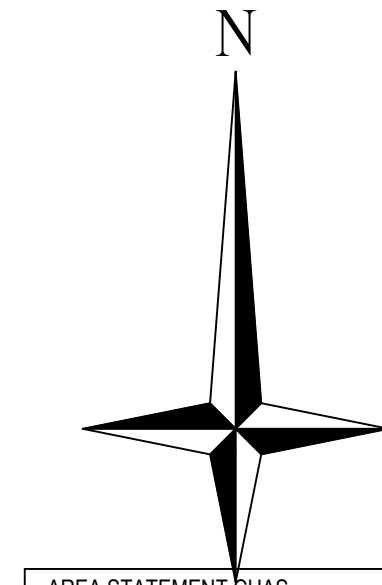

30' WIDE ROAD

SITE PLAN FOR RESIDENTIAL
SCALE - 1" = 8'-0"

AREA STATEMENT CHAS MUNICIPAL CORPORATION		VERSION NO.: 1.0.71
PROJECT DETAIL:		VERSION DATE: 16/10/2020
Region: JHARKHAND URBAN LOCAL BODIES	Plot Use: Residential	
District: BOKARO	Plot SubUse: Residential Bldg/Apartment	
Authority: CHAS MUNICIPAL CORPORATION	Plot/Nearby/Religious Structure: NA	
Inward No: CMC/BP/0293/W02/2023	Plot/SubPlot No: PLOT NO-901, 902, 903 & 904	
Application Type: General Proposal	North: Plot No. - 900 & 899	
Project Type: Building Permission	South: Road Width - 9.14	
Nature of Development: New	East: Plot No. - 904	
Location of Development Area: Old Area	West: Plot No. - 893	
AREA DETAILS:		
AREA OF PLOT (Minimum)	(A)	SQ.MT.
NET AREA OF PLOT (Gross Plot Area - Deduction from Gross Plot area)	(A-Deductions)	3436.15
Deduction for Balance Plot Area (from Gross Plot Area)		
Common Plot		372.66
Total		372.66
BALANCE AREA OF PLOT (Net Plot Area - Recreational/Amenity space)	(A-Deductions)	3063.49
PLOT AREA FOR COVERAGE (Net Plot Area)	(A-Deductions)	3436.15
Plot Area for FAR (Net Plot Area + Road Widening Area)	(A-Deductions)	3436.15
COVERAGE CHECK		
Permissible Coverage area (50.00 %)		1718.07
Proposed Coverage Area (35.27 %)		1211.89
Total Prop. Coverage Area (35.27 %)		1211.89
Balance coverage area (14.73 %)		506.18
FAR CHECK		
Perm. FAR Area (2.500)		8590.38
Total Perm. FAR area		8590.38
Residential FAR		8483.27
Proposed FAR Area		8501.27
Total Proposed FAR Area		8501.27
Consumed FAR (Factor)		2.47
Balance FAR Area		89.11
BUILT UP AREA CHECK		
Total Proposed Built Up Area		9735.35
ARCHITECT (Regd)		RAM PRATAP SINGH
ENGINEER (Regd)		
SUPERVISOR (Regd)		
OWNER (Regd)		1. SMT GITA DEVI 2. SRI. ASHOK KUMAR SHUBHAM DEVELOPER NINETY NINE BUILDERS PVT. LTD. BY ITS DIRECTOR RAM PRATAP SINGH
DEVELOPMENT AUTHORITY		LOCAL BODY

Required Parking (Table 7a)

Building Name	Type	SubUse	Area (Sq.mt.)	Units		Car		Visitors Car		TwoWheeler			
				Reqd.	Prop.	Reqd./Unit	Prop.	Reqd./Unit	Prop.	Reqd./Unit	Prop.		
A (1 GITA AND 2 ASHOK DEVELOPER NINETY NINE BUILDERS PVT LTD)	Residential	Residential Bldg/Apartment	> 0	1	56.00	1.00	56	-	-	-	-	-	
			> 0	1	56.00	-	-	-	-	-	1	56	
			> 0	1	56.00	-	-	1	6	-	-	-	
Total :			-	-	-	56	69	-	6	12	-	56	131

Parking Check (Table 7b)

Vehicle Type	Reqd.		Prop.	
	No.	Area	No.	Area
Car	-	-	69	862.50
Total Car	56	700.00	69	862.50
Visitor's Car Parking	-	-	12	150.00
Total Visitor Parking	6	75.00	12	150.00
TwoWheeler	-	-	131	262.00
Total TwoWheeler	56	112.00	131	262.00
Other Parking	-	-	-	334.35
Total		887.00		1870.85

COLOR INDEX	
PLOT BOUNDARY	Black
ABUTTING ROAD	Green
PROPOSED CONSTRUCTION	Red
COMMON PLOT	Yellow
ROAD WIDENING AREA	Blue
EXISTING (To be retained)	Orange
EXISTING (To be demolished)	Light Blue

Building USE/SUBUSE Details

Building Name	Building Use	Building SubUse	Building Structure	Floor Name	Floor Use	Floor SubUse	FAR Name	FAR Use	FAR SubUse
A (1 GITA AND 2 ASHOK DEVELOPER NINETY NINE BUILDERS PVT LTD)	Residential	Residential Bldg/Apartment	Multistoried	BASEMENT FLOOR PLAN	Residential	Residential Bldg/Apartment	-	-	-
				TYPICAL -GROUND, 1, 2, 3, 4 & 5 FLOOR PLAN	Residential	Residential Bldg/Apartment	Residential FAR	Residential	Residential Bldg/Apartment
				TERRACE FLOOR PLAN	Residential	Residential Bldg/Apartment	-	-	-

FAR & Tenement Details (Table 4c-1)

Building	No. of Same Bldg	Gross Built Up Area (Sq.mt.)	Deductions From Gross BU(A)Area in (Sq.mt.)	Total Built Up Area (Sq.mt.)	Deductions (Area in Sq.mt.)		Proposed FAR Area (Sq.mt.)	Add Area In FAR (Sq.mt.)	Total FAR Area (Sq.mt.)	Total Consumed Additional FAR Area (Sq.mt.)	Trmt (No.)
					Lift	Parking					
A (1 GITA AND 2 ASHOK DEVELOPER NINETY NINE BUILDERS PVT LTD)	1	10016.40	281.05	9735.35	16.19	1217.85	8483.30	18.01	8501.31	8501.31	56
Grand Total :	1	10016.40	281.05	9735.35	16.19	1217.85	8483.30	18.01	8501.31	8501.31	56

Buildingwise Floor FAR Details

Floor Name	Building Name		Total	
	Proposed Built Up Area (Sq.mt.)	Proposed FAR Area (Sq.mt.)	Total Proposed Built Up Area (Sq.mt.)	Total FAR Area (Sq.mt.)
Basement Floor	1252.05	18.01	1252.05	18.01
Ground Floor	1211.90	1211.90	1211.90	1211.90
First Floor	1211.90	1211.90	1211.90	1211.90
Second Floor	1211.90	1211.90	1211.90	1211.90
Third Floor	1211.90	1211.90	1211.90	1211.90
Fourth Floor	1211.90	1211.90	1211.90	1211.90
Fifth Floor	1211.90	1211.90	1211.90	1211.90
Sixth Floor	1211.90	1211.90	1211.90	1211.90
Terrace Floor	0.00	0.00	0.00	0.00
Total :	9735.35	8501.31	9735.35	8501.31

LTP NAME AND SIGNATURE	STRUCTURAL ENG'S NAME AND SIGNATURE	BUILDER NAME AND SIGNATURE	DIGITAL SIGNATURE
RAM PRATAP SINGH CMC/ARC/0005/2019			

Proposal Basic Information

Proposal File No.	CMC/BP/0293/W02/2023
Owner Name	1. SMT GITA DEVI 2. SRI ASHOK KUMAR SHUBHAM DEVELOPER NINETY NINE BUILDERS PVT. LTD. BY ITS DIRECTOR RAM PRATAP SINGH
Khata No	KHATA NO-188
Plot No	PLOT NO-901, 902, 903 & 904
Village Name	Chas
Use	Residential
SubUse	Residential Bldg/Apartment



FRONT ELEVATION
SCALE - 1" = 8'-0"

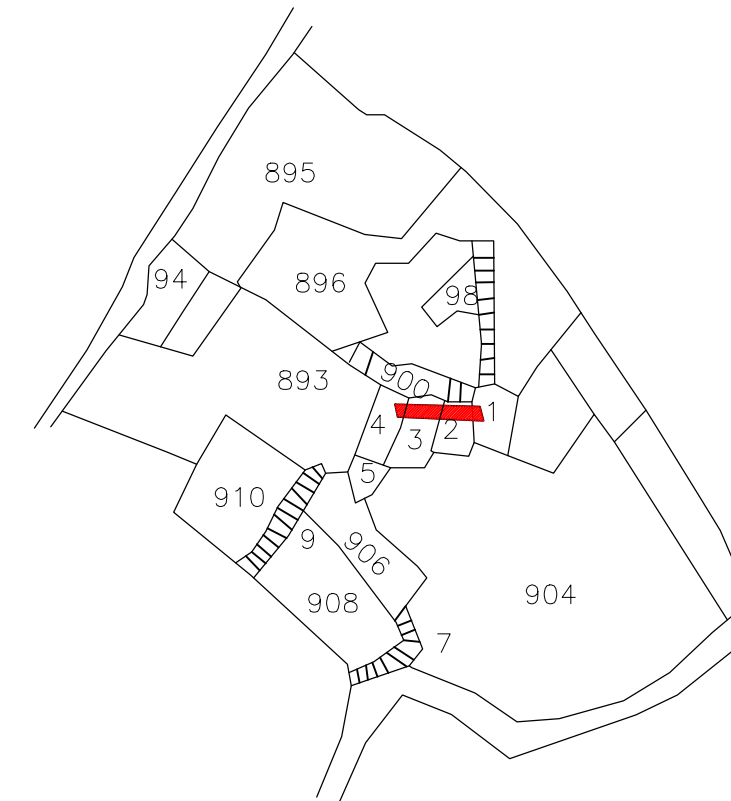

KEY PLAN
NOT TO SCALE

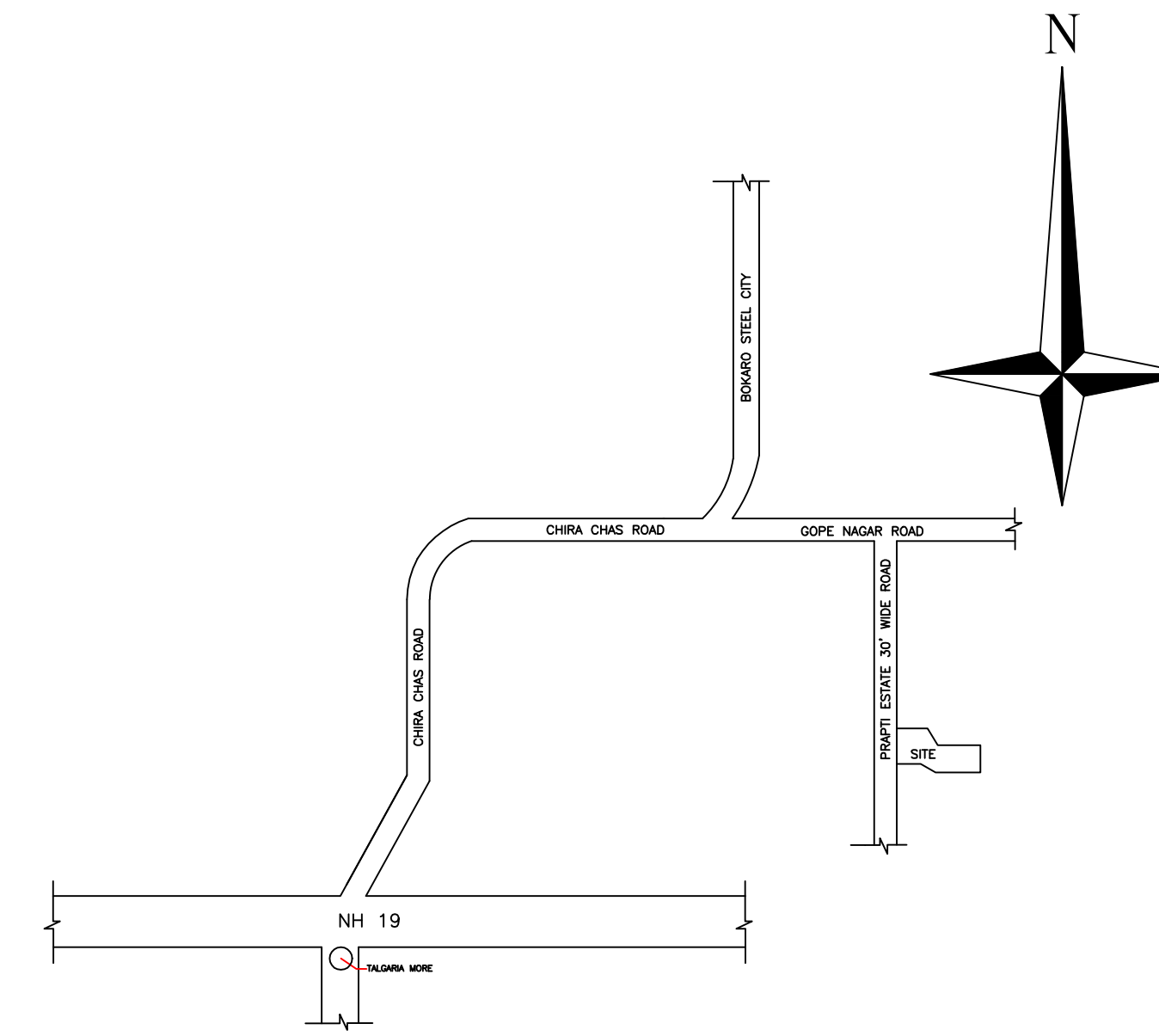

LOCATION PLAN
NOT TO SCALE

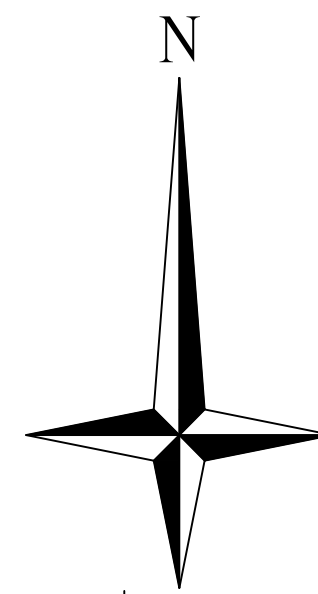

SCHEDULE OF ROOMS

Sl. No.	Room Name	Area (sq. ft.)	Remarks
1	Bed Room	3.97x3.96	
2	Living/Kitchen	3.84x4.22	
3	Hall	3.35x3.35	
4	Bed Room	3.96x3.35	
5	Hall	3.35x3.35	
6	Bed Room	3.66x3.35	
7	Living/Kitchen	6.80x4.05	
8	Drawing Room	4.57x3.35	
9	Bed Room	4.57x3.35	
10	Bed Room	4.57x3.35	
11	Bed Room	4.57x3.35	
12	Bed Room	4.57x3.35	
13	Living/Kitchen	7.62x3.35	
14	Drawing Room	4.57x3.35	
15	Bed Room	4.57x3.35	
16	Bed Room	4.57x3.35	
17	Living/Dining	9.26x7.43	
18	Kitchen	3.30x3.05	
19	Bed Room	3.30x3.05	
20	Bed Room	3.66x4.27	
21	Bed Room	3.30x3.05	
22	Bed Room	3.47x2.76	
23	Bed Room	3.30x3.05	
24	Bed Room	3.47x2.76	

SCHEDULE OF MATERIALS

Sl. No.	Material Name	Quantity	Remarks
1	Concrete		
2	Brick		
3	Steel		
4	Plaster		
5	Paint		
6	Window Glass		
7	Door		
8	Sanitary Ware		
9	Electrical		
10	Roofing		
11	Insulation		
12	Handrails		
13	Staircase		
14	Handrails		
15	Staircase		
16	Handrails		
17	Staircase		
18	Handrails		
19	Staircase		
20	Handrails		
21	Staircase		
22	Handrails		
23	Staircase		
24	Handrails		
25	Staircase		
26	Handrails		
27	Staircase		
28	Handrails		
29	Staircase		
30	Handrails		

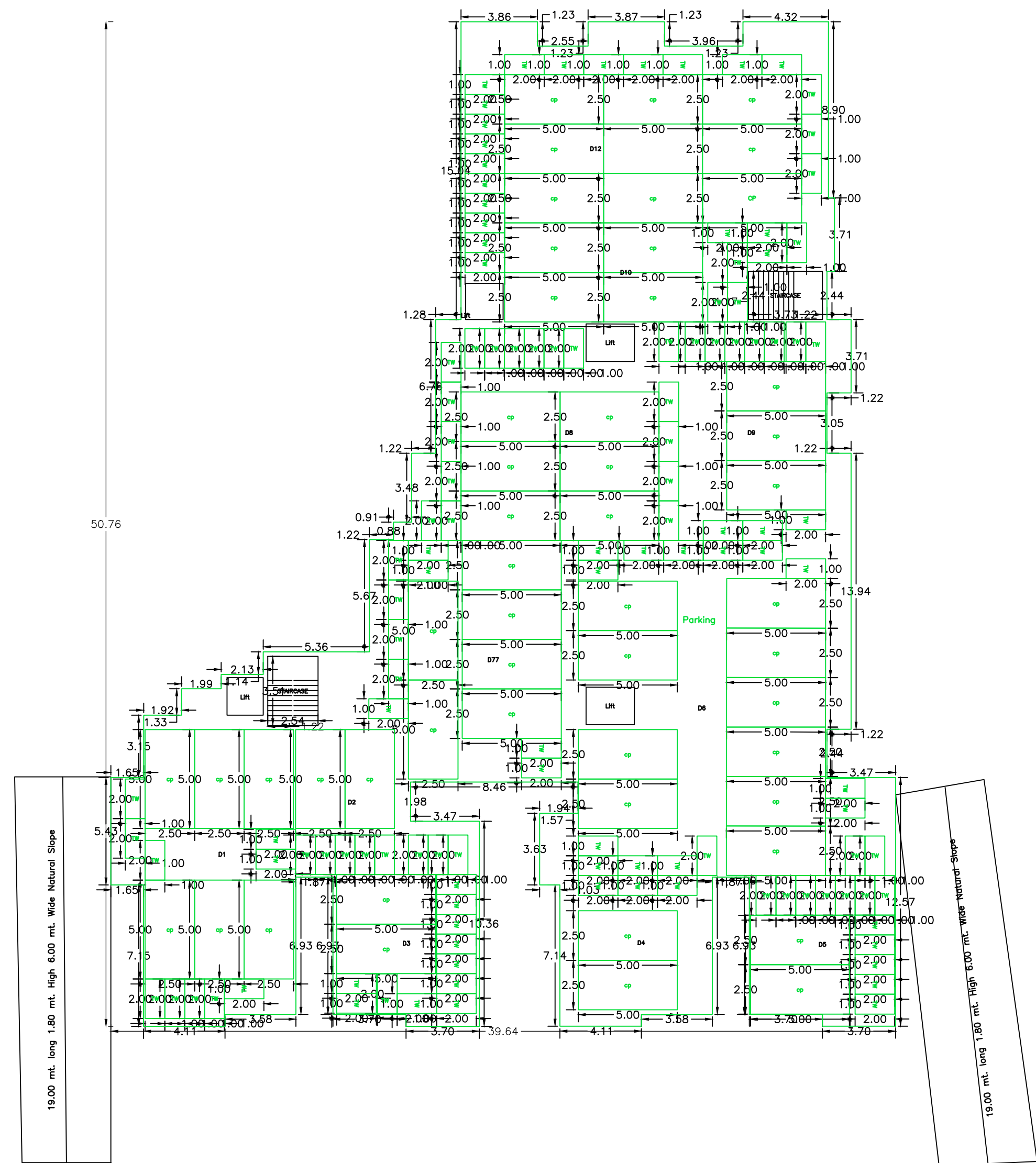

BASEMENT FLOOR PLAN
SCALE 1:100

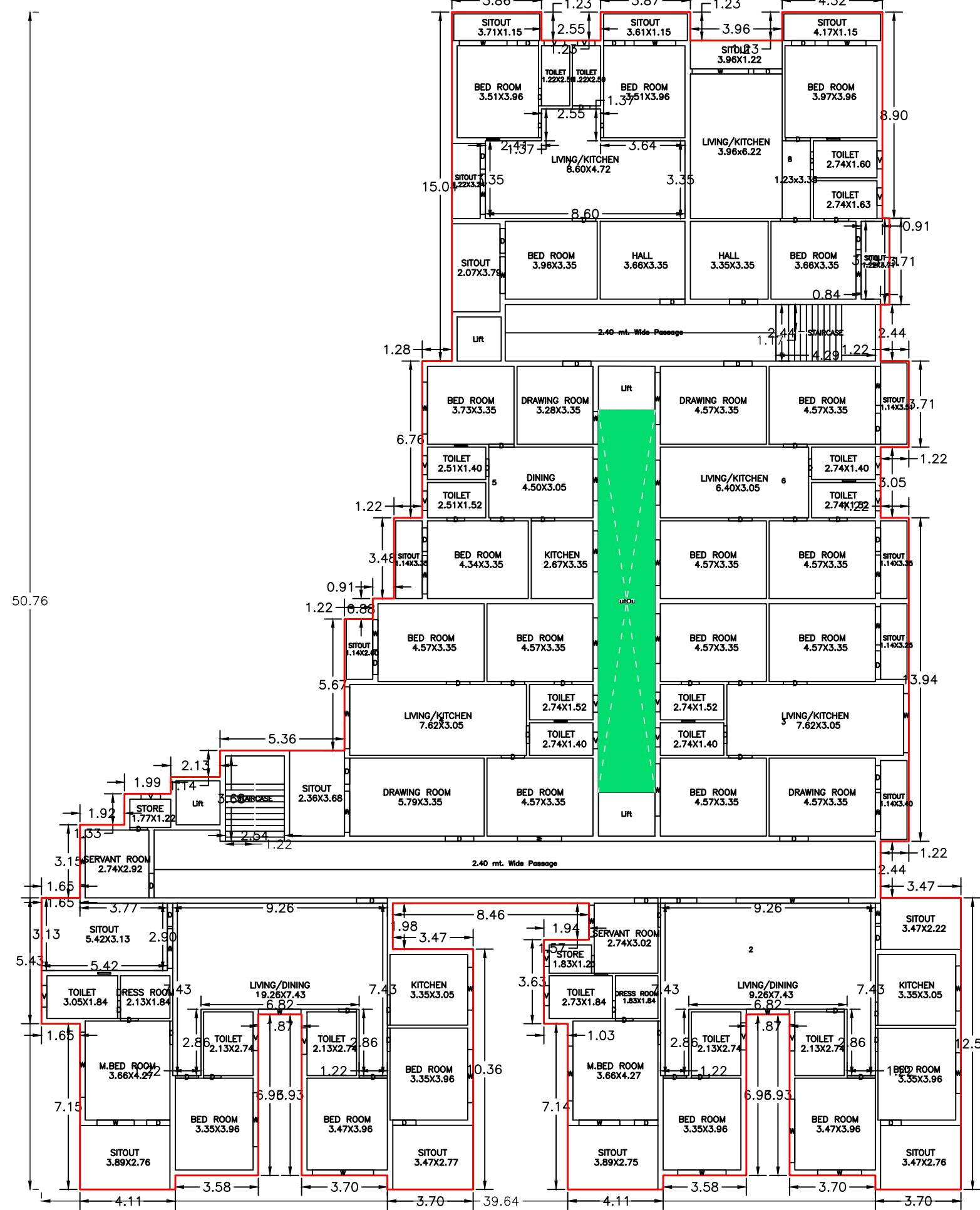

TYPICAL - GROUND, 1, 2, 3, 4, 5 & 6 FLOOR PLAN
(Proposed)
SCALE 1:100

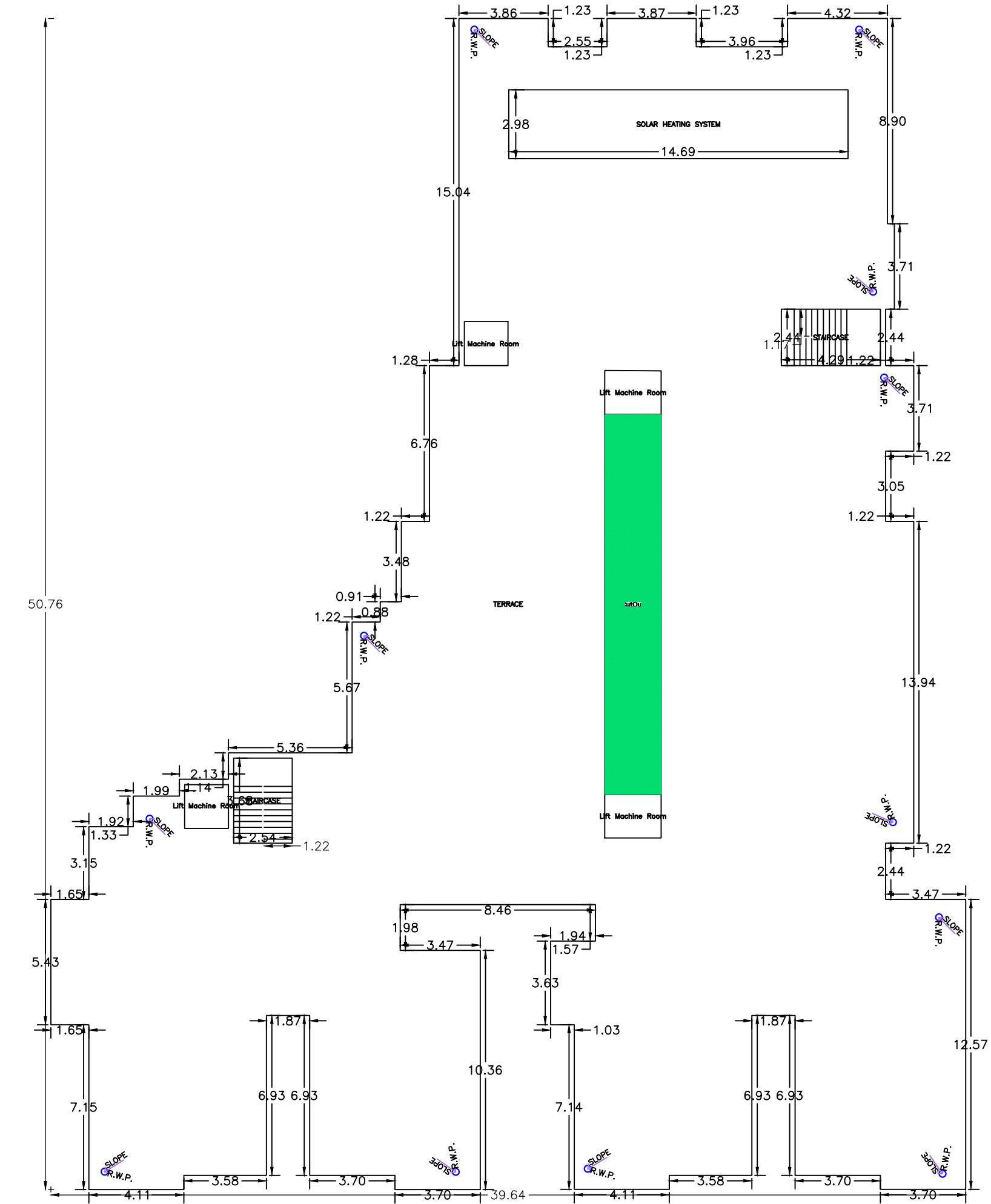

LTP NAME AND SIGNATURE RAM PRATAP SINGH (Proposed) CMC/ARC/0005/2019	STRUCTURAL ENG'S NAME AND SIGNATURE	BUILDER NAME AND SIGNATURE	DIGITAL SIGNATURE
---	-------------------------------------	----------------------------	-------------------

Proposal Basic Information	
Proposal File No.	CMC/BP/0293/W02/2023
Owner Name	1. SMT GITA DEVI 2. SRI ASHOK KUMAR SHUBHAM DEVELOPER NINETY NINE BUILDERS PVT. LTD. BY ITS DIRECTOR RAM PRATAP SINGH
Khata No	KHATA NO-188
Plot No	PLOT NO-901, 902, 903 & 904
Village Name	Chas
Use	Residential
SubUse	Residential Bldg/Apartment



RIGHT SIDE ELEVATION
SCALE - 1" = 8'-0"

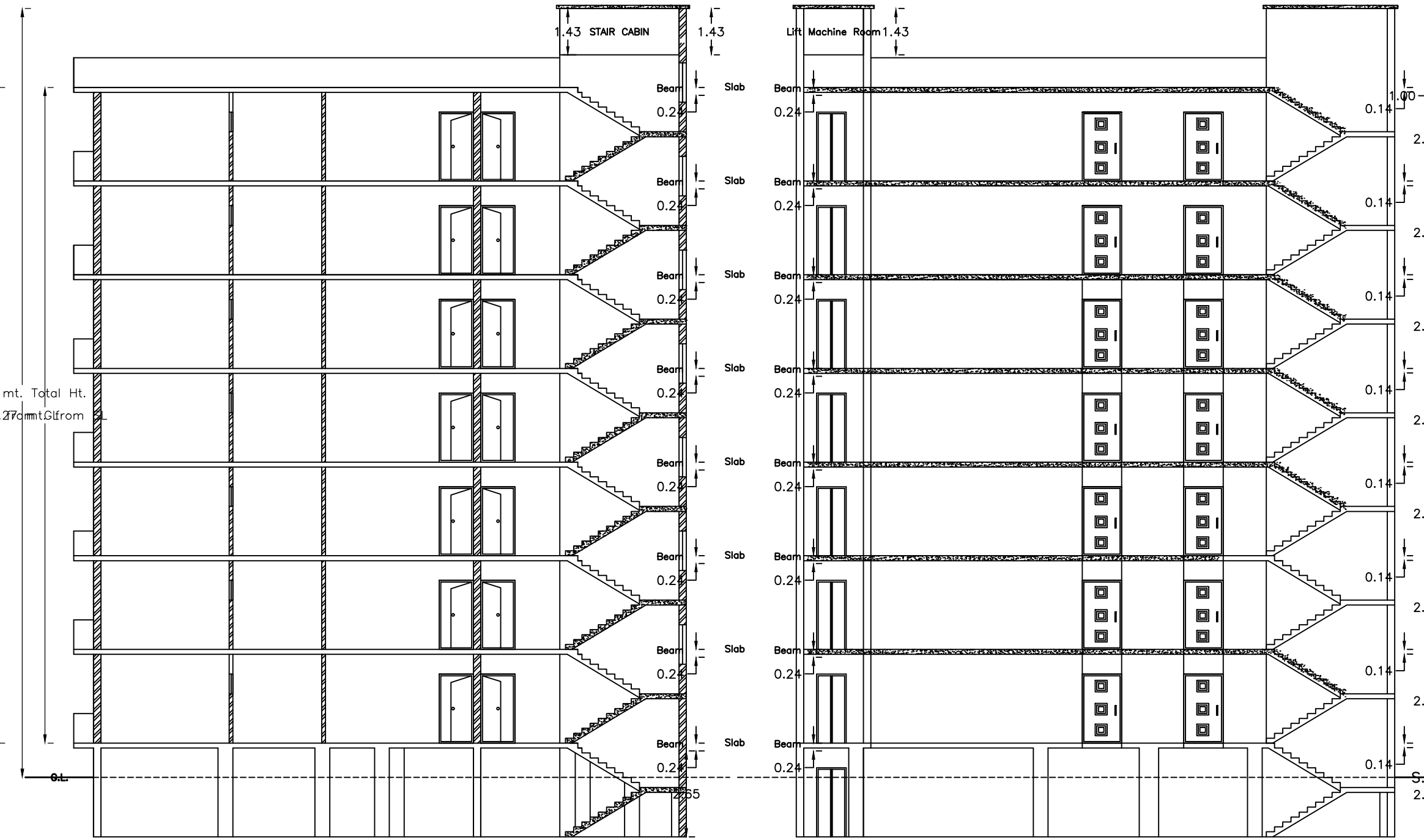

SECTION - XX'
SCALE - 1" = 8'-0"

SECTION - YY'
SCALE - 1" = 8'-0"

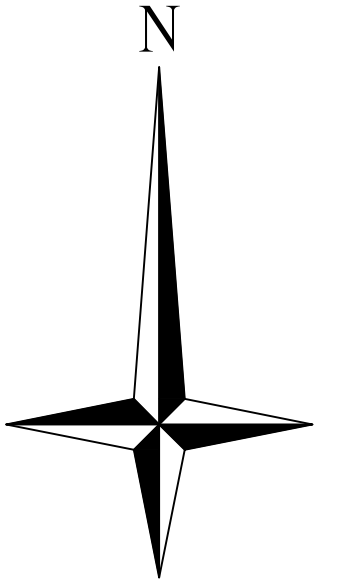

UnitBUA Table for Building :A (1 GITA AND 2 ASHOK DEVELOPER NINETY NINE BUILDERS PVT LTD)

FLOOR	Name	UnitBUA Type	UnitBUA Area	Carpet Area	No. of Rooms	No. of Tenement
TYPICAL - GROUND, 1, 2, 3, 4, 5 & 6 FLOOR PLAN	1	FLAT	193.26	193.22	15	56
	2	FLAT	183.61	183.58	15	
	3	FLAT	106.18	106.15	9	
	4	FLAT	114.13	114.09	9	
	5	FLAT	76.03	75.99	8	
	6	FLAT	102.15	102.12	9	
	7	FLAT	119.96	119.92	11	
	8	FLAT	96.52	96.48	9	
Total:	-	-	6942.83	6940.84	595	56

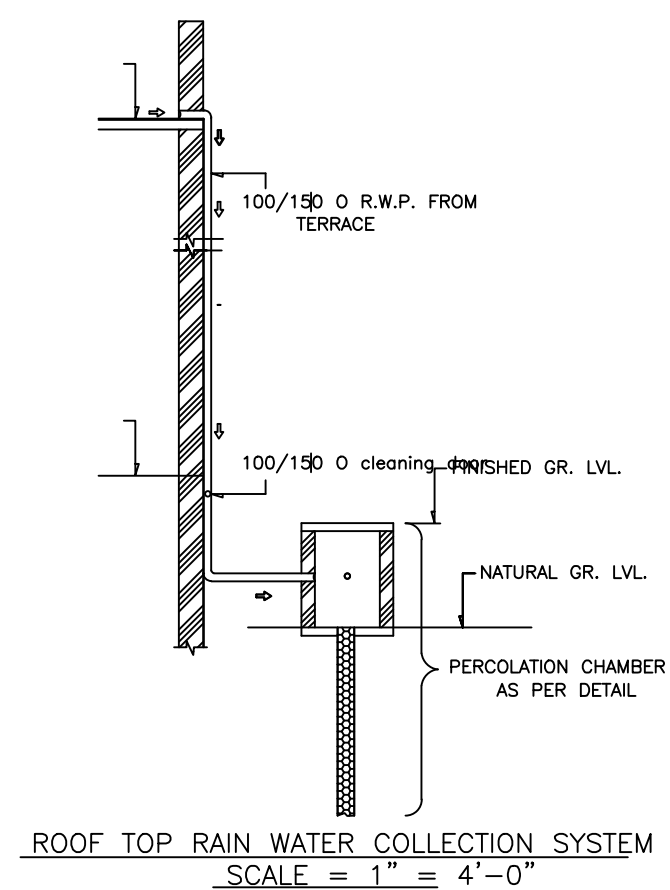

ROOF TOP RAIN WATER COLLECTION SYSTEM
SCALE = 1" = 4'-0"

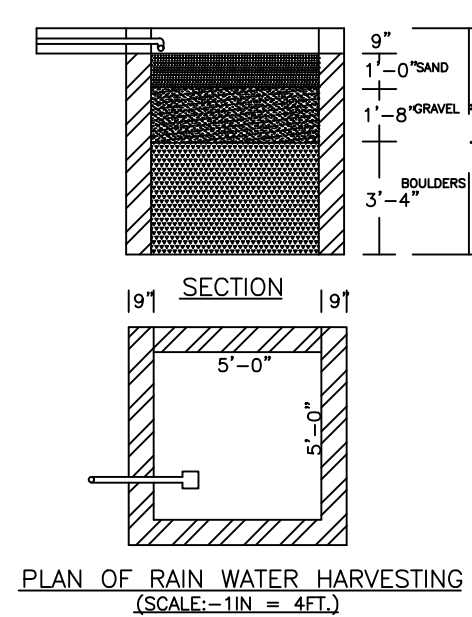

PLAN OF RAIN WATER HARVESTING
SCALE:- 1IN = 4FT

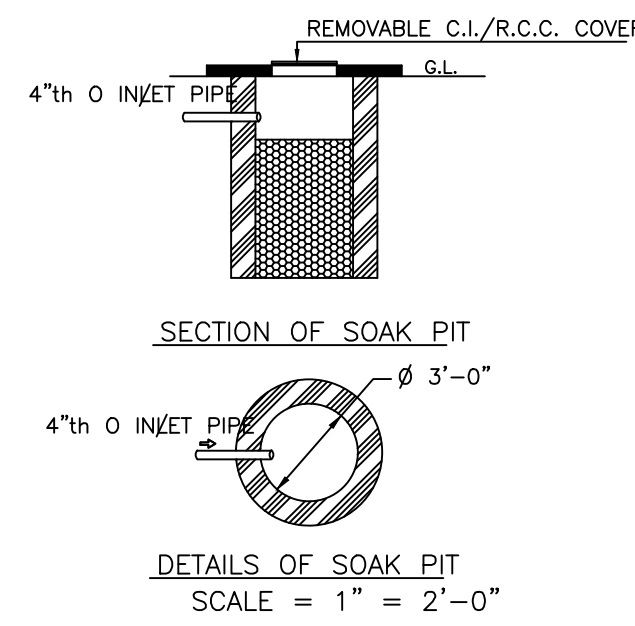

DETAILS OF SOAK PIT
SCALE = 1" = 2'-0"

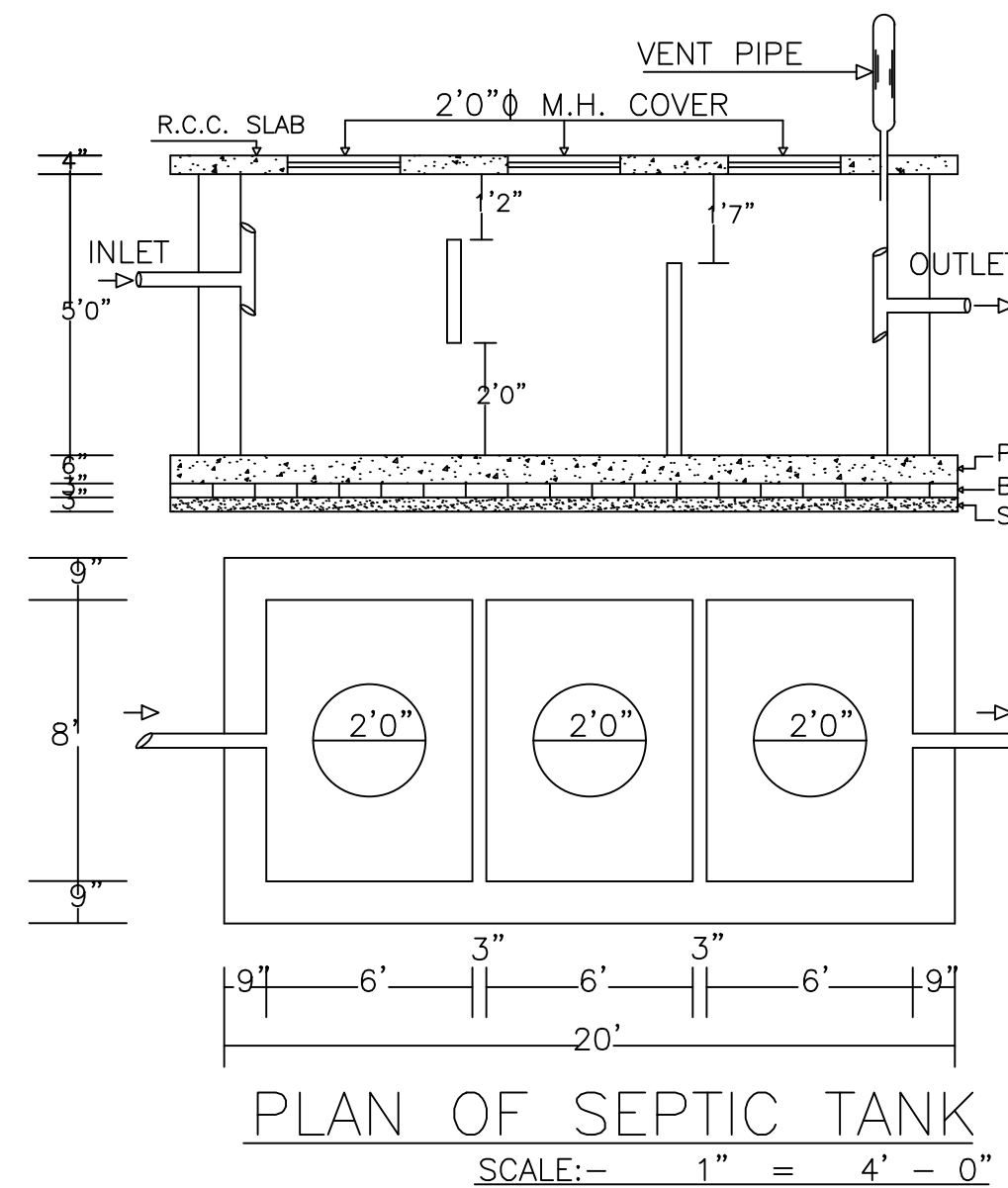

PLAN OF SEPTIC TANK
SCALE:- 1" = 4'-0"

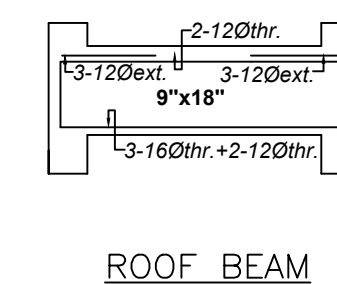

ROOF BEAM

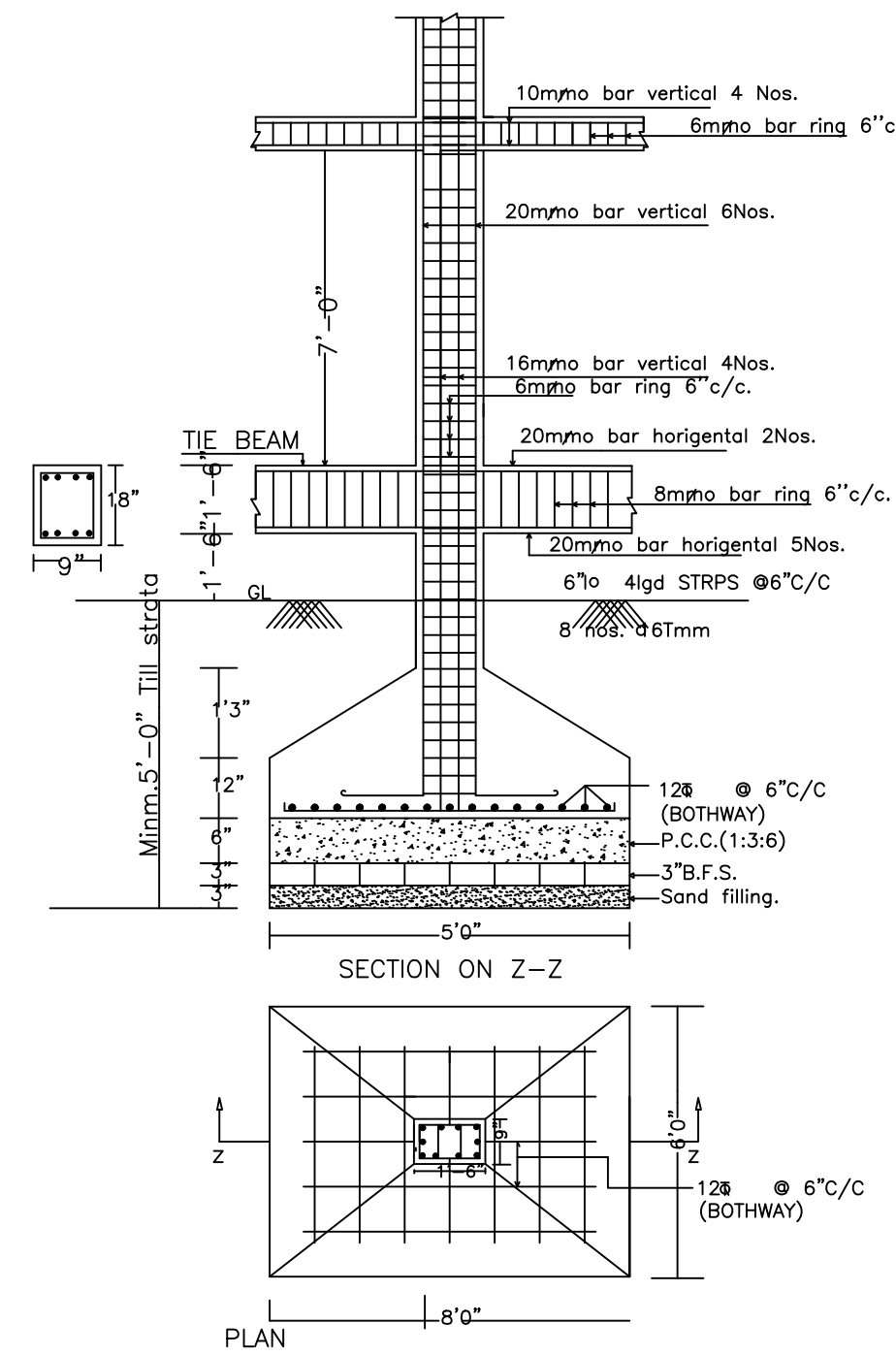

DETAIL OF COLUMNS

Building :A (1 GITA AND 2 ASHOK DEVELOPER NINETY NINE BUILDERS PVT LTD)

Floor Name	Gross Builtup Area	Deductions From Gross BUA/Area in Sq.mt.	Total Built Up Area (Sq.mt.)	Deductions (Area in Sq.mt.)		Proposed FAR Area (Sq.mt.)	Add Area in FAR (Sq.mt.)	Total FAR Area (Sq.mt.)	Total Consumed Additional FAR Area (Sq.mt.)	Trmt (No.)
				Lift	Parking					
Basement Floor	1252.05	0.00	1252.05	16.19	1217.85	0.00	18.01	18.01	18.01	00
Ground Floor	1252.05	40.15	1211.90	0.00	0.00	1211.90	0.00	1211.90	1211.90	08
First Floor	1252.05	40.15	1211.90	0.00	0.00	1211.90	0.00	1211.90	1211.90	08
Second Floor	1252.05	40.15	1211.90	0.00	0.00	1211.90	0.00	1211.90	1211.90	08
Third Floor	1252.05	40.15	1211.90	0.00	0.00	1211.90	0.00	1211.90	1211.90	08
Fourth Floor	1252.05	40.15	1211.90	0.00	0.00	1211.90	0.00	1211.90	1211.90	08
Fifth Floor	1252.05	40.15	1211.90	0.00	0.00	1211.90	0.00	1211.90	1211.90	08
Sixth Floor	1252.05	40.15	1211.90	0.00	0.00	1211.90	0.00	1211.90	1211.90	08
Terrace Floor	0.00	0.00	0.00	0.00	0.00	0.00	0.00	0.00	0.00	00
Total:	10016.40	281.05	9735.35	16.19	1217.85	8483.30	18.01	8501.31	8501.31	56
Total Number of Same Buildings :	1									

LTP NAME AND SIGNATURE	STRUCTURAL ENG'S NAME AND SIGNATURE	BUILDER NAME AND SIGNATURE	DIGITAL SIGNATURE
RAM PRATAP SINGH CMC/ARC/0005/2019			