

Proposal Basic Information

Proposal File No.	CMC/BP/0310/W29/2023
Owner Name	SHWETA SINGH
Khata No	24
Plot No	1017
Village Name	Telidih
Use	Residential
SubUse	Bungalow/ Dwelling / Non Apartment

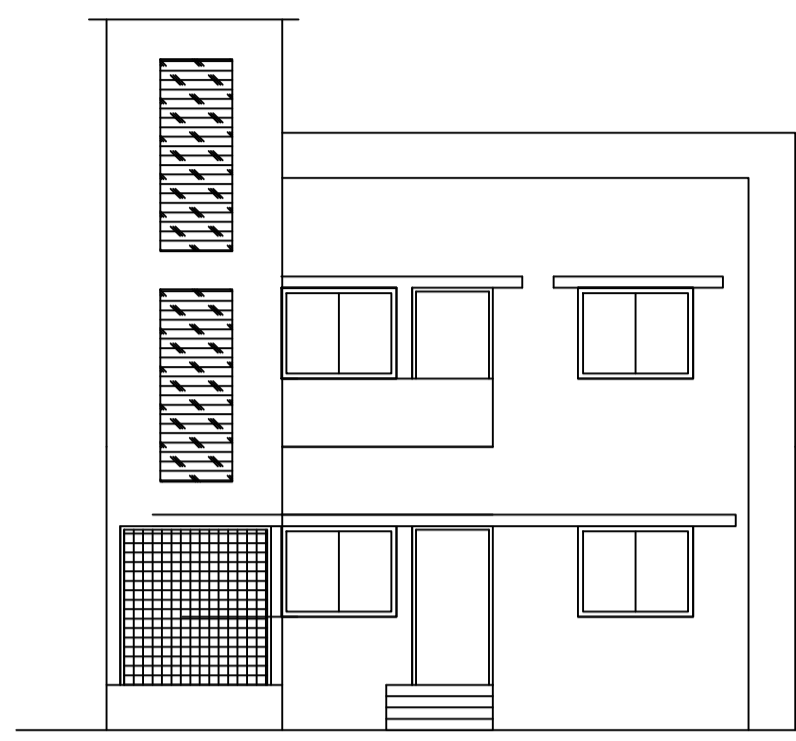

FRONT ELEVATION

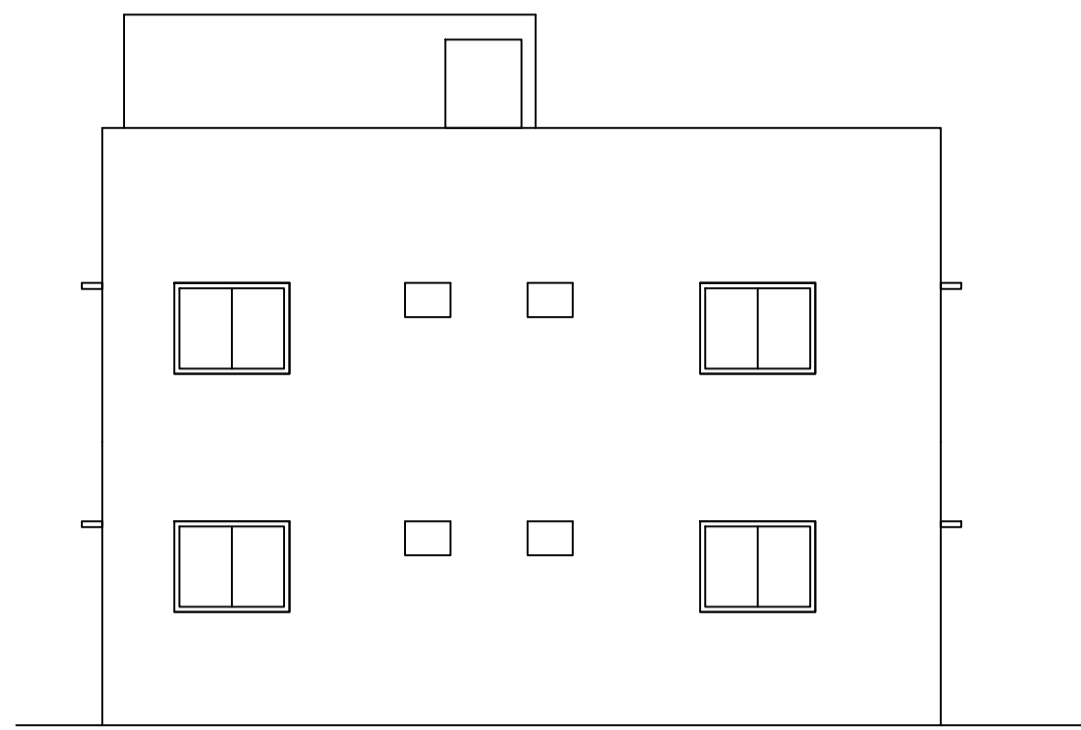

SIDE ELEVATION

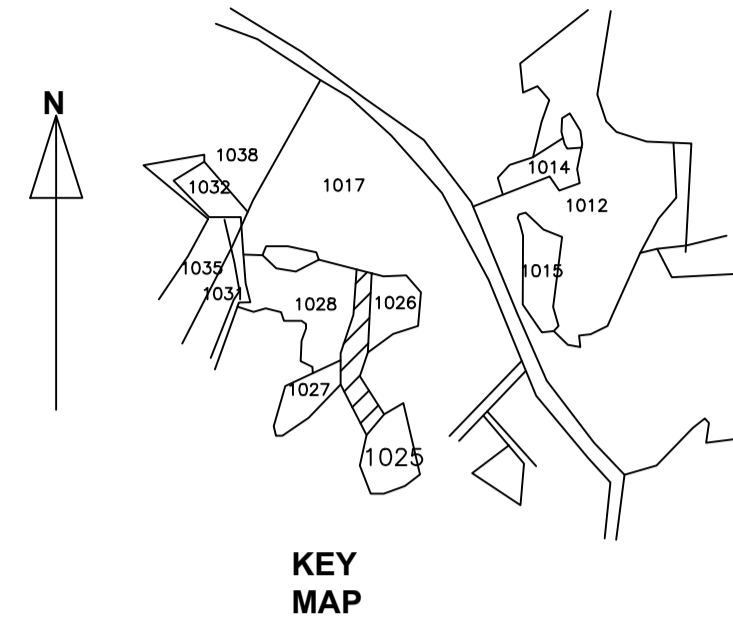

KEY MAP

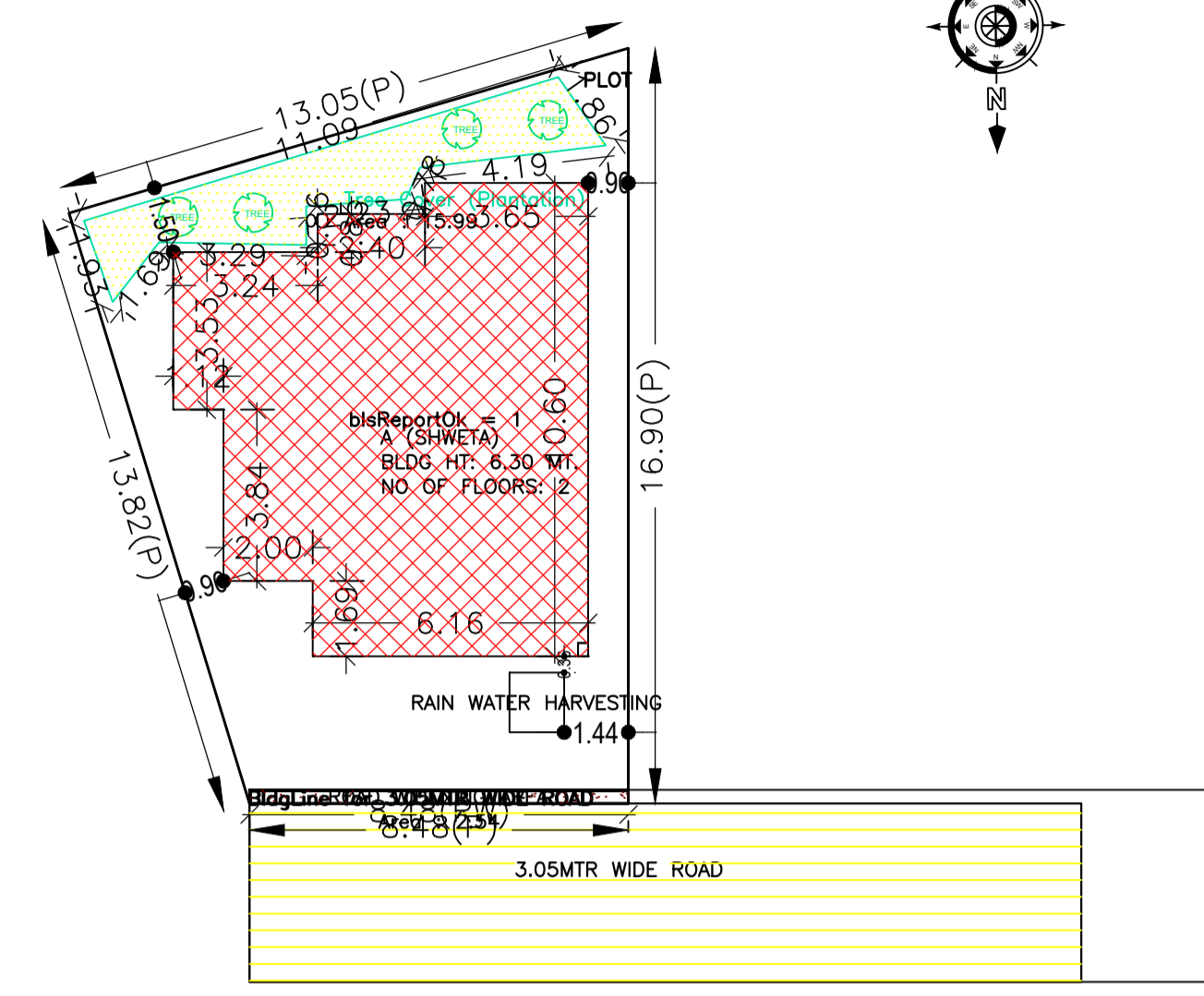

SITE PLAN

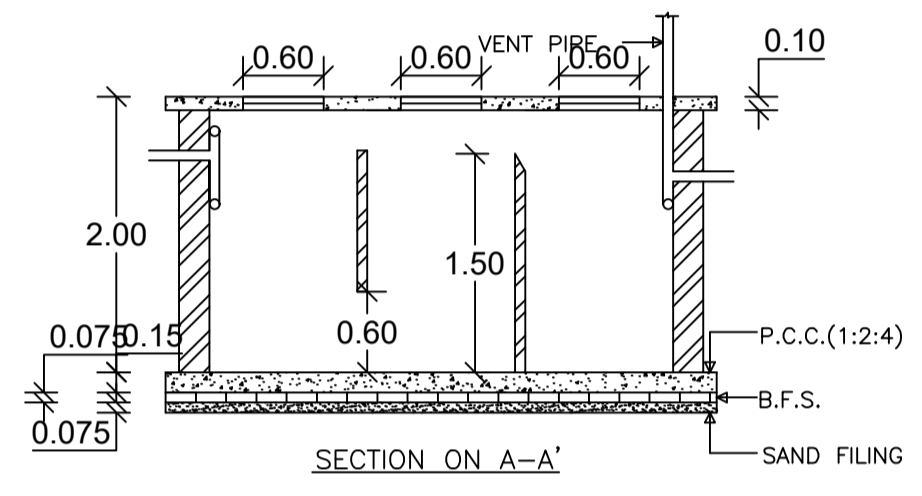

SECTION ON A-A'

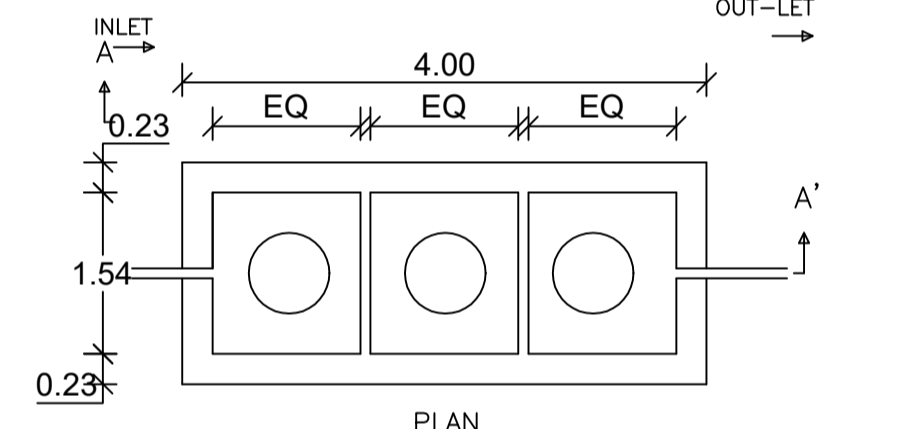

DETAILS OF SEPTIC TANK

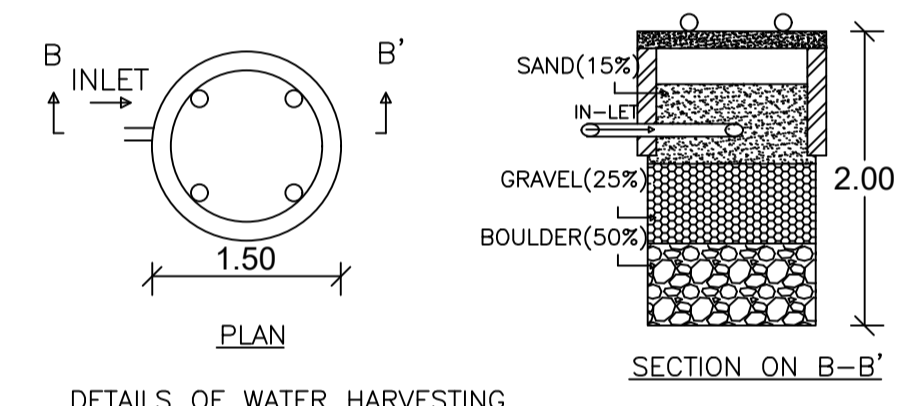

DETAILS OF WATER HARVESTING

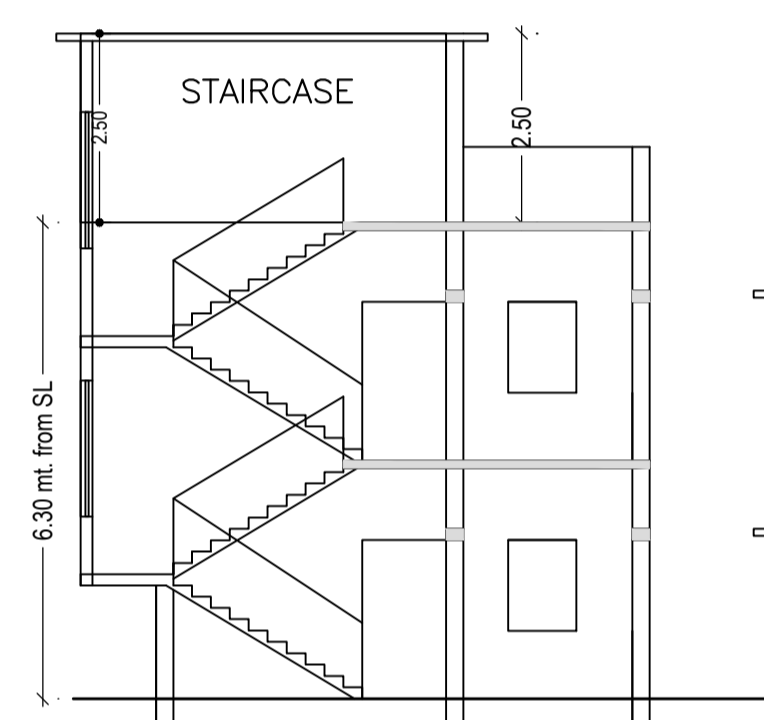

SECTION ON X-X

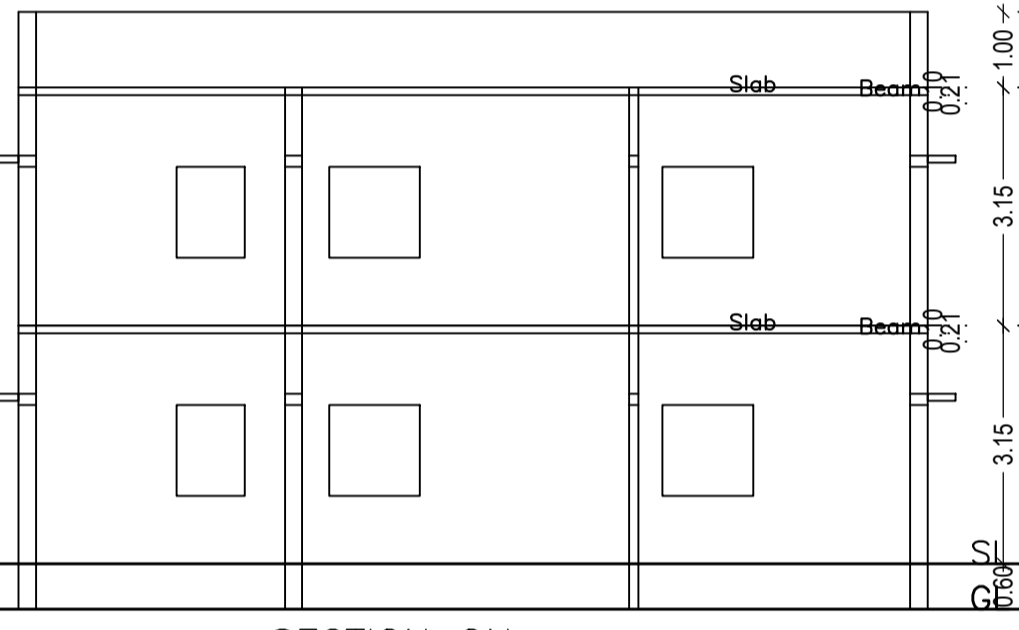

SECTION ON Y-Y

AREA STATEMENT CHAS MUNICIPAL CORPORATION	VERSION NO.: 1.0.68	SQ.MT.
PROJECT DETAIL:	VERSION DATE: 16/10/2020	
Region: JHARKHAND URBAN LOCAL BODIES	Plot Use: Residential	
District: BOKARO	Plot SubUse: Bungalow/ Dwelling / Non Apartment	
Authority: CHAS MUNICIPAL CORPORATION	Plot Nearby/Religious/Structure: NA	
Inward No: CMC/BP/0310/W29/2023	Plot SubPlot No: 1017	
Application Type: General Proposal	North: Road Width - 3.05 MTR WIDE ROAD	
Project Type: Building Permission	South: Plot No. - PLOT NO - 1017 SARITA DEVI	
Nature of Development: New	East: CTS No. - SONIA DEVI AND RASTA	
Location of Development Area: Old Area	West: CTS No. - DHARMENDRA TIWARI	
AREA OF PLOT (Minimum)	(A)	161.88
Deduction for NetPlot Area		
Road Widening Area		2.54
Total		2.54
NET AREA OF PLOT(Gross Plot Area - Deduction from Gross Plot area)	(A-Deductions)	159.34
Deduction for Balance Plot Area(from Gross Plot Area)		
Road Widening Area		2.54
Common Plot		15.99
Total		18.53
BALANCE AREA OF PLOT(Net Plot Area - Recreational/Amenity space)	(A-Deductions)	143.35
PLOT AREA FOR COVERAGE(Net Plot Area)	(A-Deductions)	159.34
Plot Area for FAR (Net Plot Area + RoadWidening Area)	(A-Deductions)	159.34
COVERAGE CHECK		
Permissible Coverage area (70.00 %)		111.54
Proposed Coverage Area (51.58 %)		82.18
Total Prop. Coverage Area (51.58 %)		82.18
Balance coverage area (18.43 %)		29.36
FAR CHECK		
Perm. FAR Area (1.200)		191.21
Total Perm. FAR area		191.21
Residential FAR		164.37
Proposed FAR Area		164.37
Total Proposed FAR Area		164.37
Consumed FAR (Factor)		1.03
Balance FAR Area		26.84
BUILT UP AREA CHECK		
Total Proposed BuiltUp Area		164.36
ARCHITECT (Regd)	AMRIT KUMAR MAHATO	
ENGINEER (Regd)		
SUPERVISOR (Regd)		
OWNER (Regd)	SHWETA SINGH	
DEVELOPMENT AUTHORITY	LOCAL BODY	

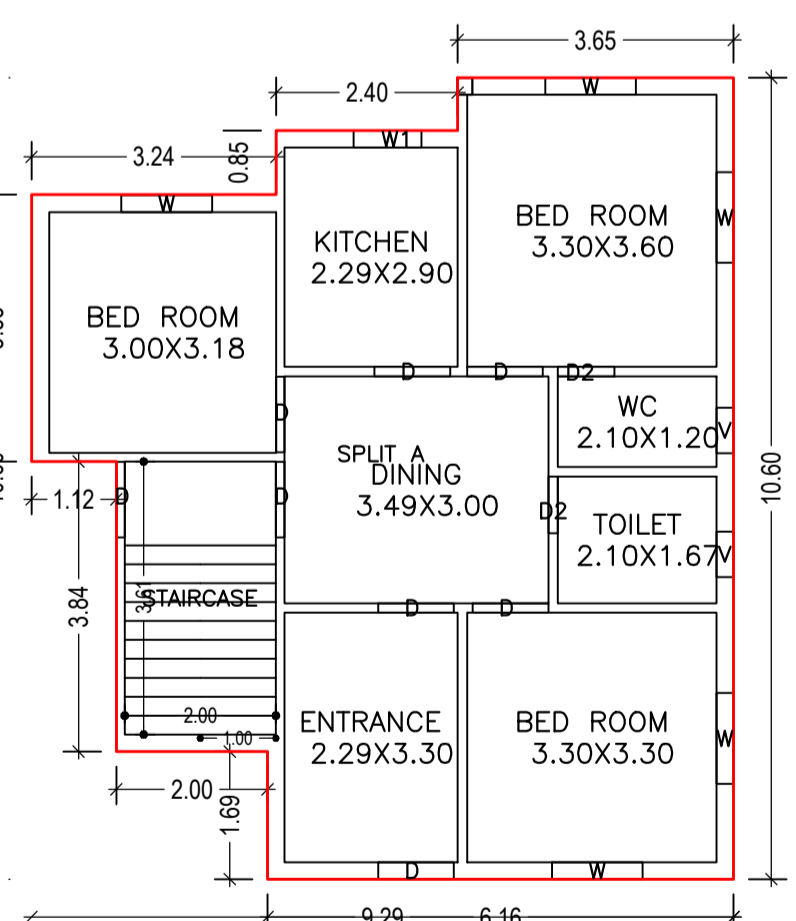

GROUND FLOOR PLAN (Proposed) (SCALE 1:100)

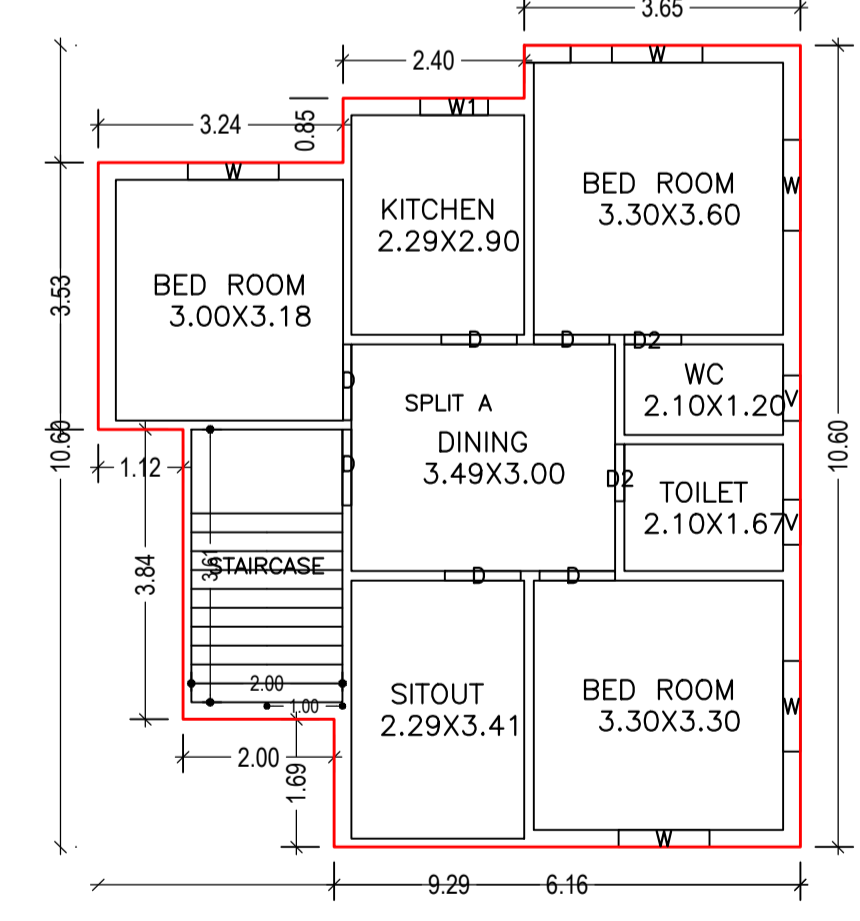

FIRST FLOOR PLAN (Proposed) (SCALE 1:100)

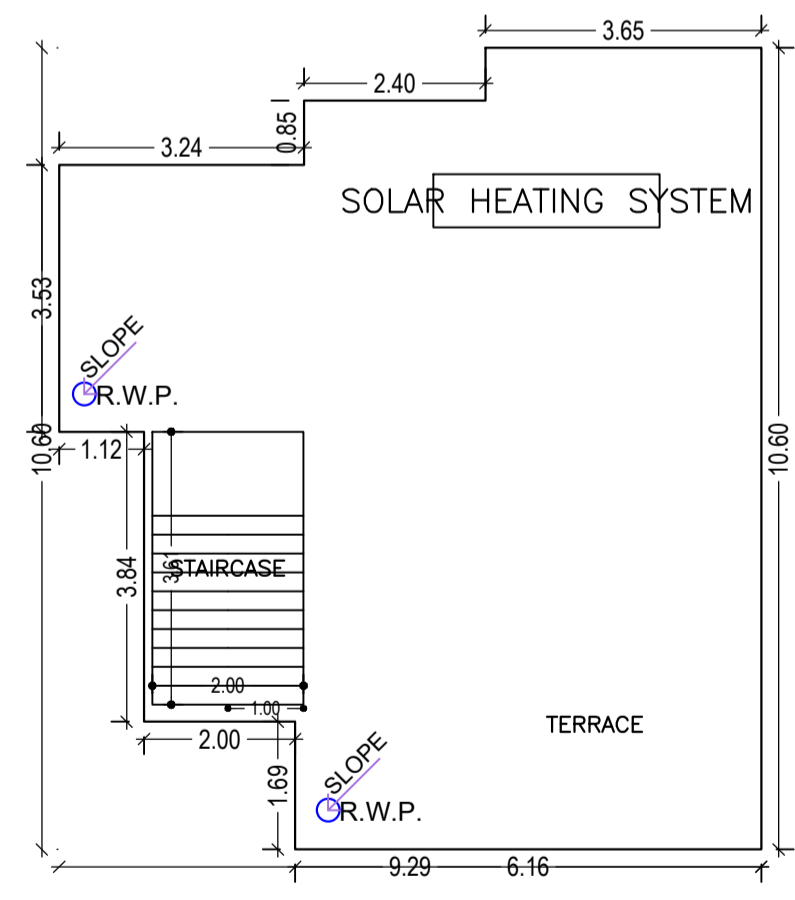

TERRACE FLOOR PLAN (SCALE 1:100)

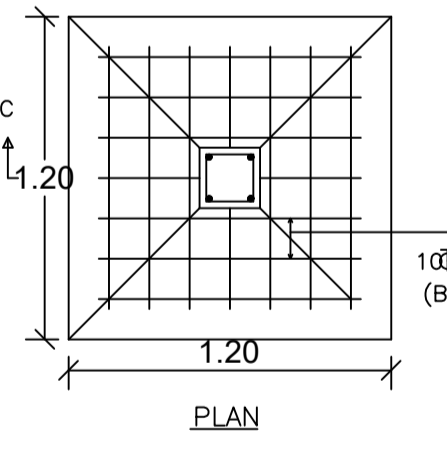

DETAILS OF FOUNDATION

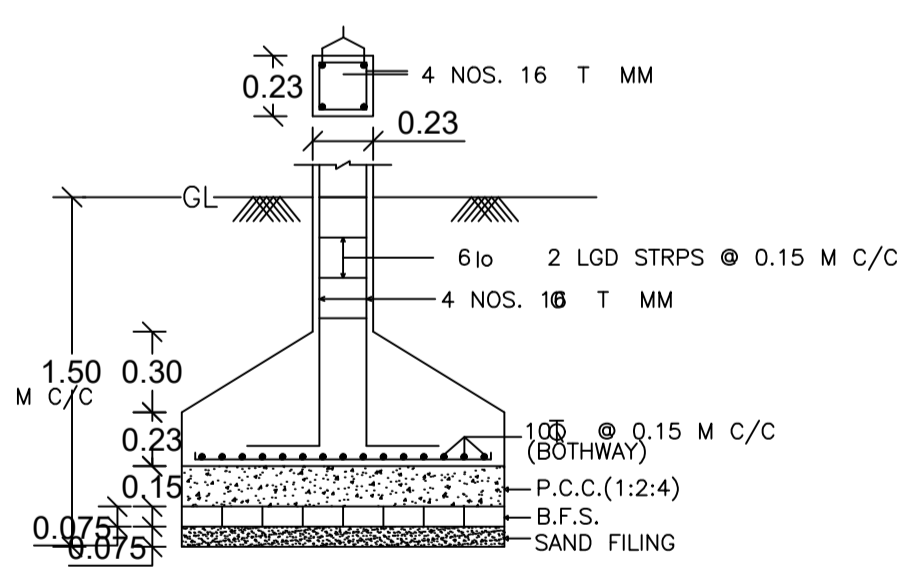

SECTION ON C-C'

Building :A (SHWETA)

Floor Name	Total Built Up Area (Sq.mt.)	Proposed FAR Area (Sq.mt.)	Total FAR Area (Sq.mt.)	Total Consumed Additional FAR Area (Sq.mt.)	Tnmt (No.)
Ground Floor	82.18	82.18	82.18	82.18	01
First Floor	82.18	82.18	82.18	82.18	00
Terrace Floor	0.00	0.00	0.00	0.00	00
Total :	164.36	164.36	164.36	164.36	01
Total Number of Same Buildings :	1				
Total :	164.36	164.36	164.36	164.36	01

SCHEDULE OF DOOR:

BUILDING NAME	NAME	LENGTH	HEIGHT	NOS
A (SHWETA)	D2	0.75	2.10	04
A (SHWETA)	D	1.00	2.10	13

SCHEDULE OF WINDOW/VENTILATION:

BUILDING NAME	NAME	LENGTH	HEIGHT	NOS
A (SHWETA)	V	0.60	0.90	04
A (SHWETA)	W1	0.90	1.20	02
A (SHWETA)	W	1.20	1.20	10

Buildingwise Floor FAR Details

Floor Name	Building Name A (SHWETA)		Total	
	Proposed Built Up Area (Sq.mt.)	Proposed FAR Area (Sq.mt.)	Total Proposed Built Up Area (Sq.mt.)	Total FAR Area (Sq.mt.)
Ground Floor	82.18	82.18	82.18	82.18
First Floor	82.18	82.18	82.18	82.18
Terrace Floor	0.00	0.00	0.00	0.00
Total :	164.36	164.36	164.36	164.36

UnitBUA Table for Building :A (SHWETA)

FLOOR	Name	UnitBUA Type	UnitBUA Area	Carpet Area	No. of Rooms	No. of Tenement
GROUND FLOOR PLAN	SPLIT A	FLAT	164.37	164.18	8	1
FIRST FLOOR PLAN	SPLIT A	FLAT	0.00	0.00	8	0
Total:	-	-	164.37	164.18	16	1

FAR & Tenement Details (Table 4c-1)

Building	No. of Same Bldg	Total Built Up Area (Sq.mt.)	Proposed FAR Area (Sq.mt.)	Total FAR Area (Sq.mt.)	Total Consumed Additional FAR Area (Sq.mt.)	Tnmt (No.)
A (SHWETA)	1	164.36	164.36	164.36	164.36	01
Grand Total :	1	164.36	164.36	164.36	164.36	01

Building USE/SUBUSE Details

Building Name	Building Use	Building SubUse	Building Structure
A (SHWETA)	Residential	Bungalow/ Dwelling / Non Apartment	Non-Highrise

COLOR INDEX

PLOT BOUNDARY	Black
ABUTTING ROAD	Green
PROPOSED CONSTRUCTION COMMON PLOT	Red
ROAD WIDENING AREA	Yellow
EXISTING (To be retained)	Blue
EXISTING (To be demolished)	Orange

LTP NAME AND SIGNATURE	STRUCTURAL ENG'S NAME AND SIGNATURE	BUILDER NAME AND SIGNATURE	DIGITAL SIGNATURE
AMRIT KUMAR MAHATO CMC/DFTM/0004/2019			