

Proposal Basic Information	
Proposal File No.	CMC/BP/0317/W34/2023
Owner Name	RADHA DEVI
Khata No	737
Plot No	7789
Village Name	Chas
Use	Residential
SubUse	Bungalow/ Dwelling / Non Apartment

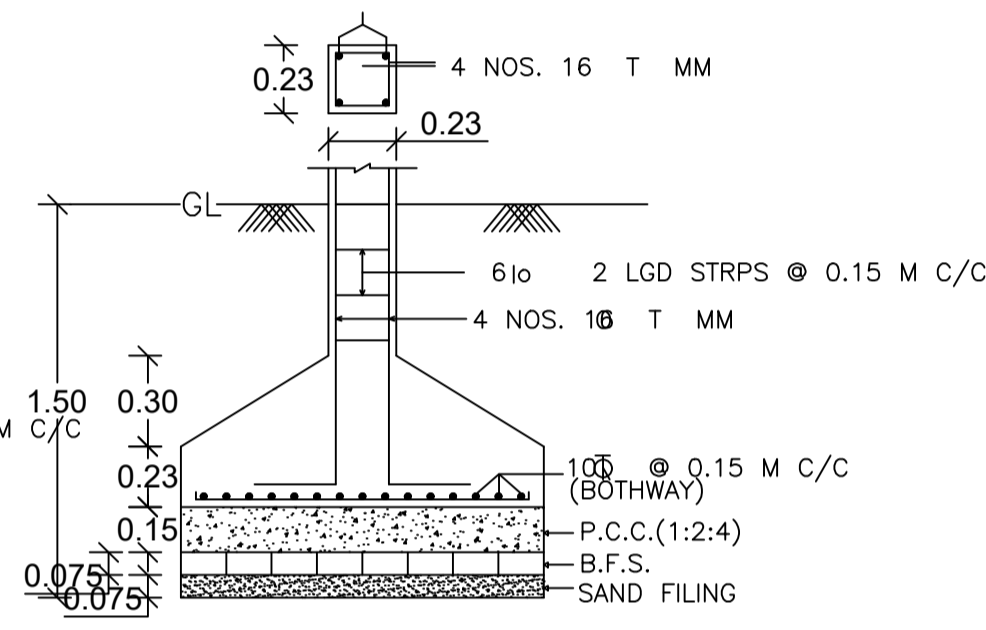

AREA STATEMENT CHAS MUNICIPAL CORPORATION		VERSION NO. : 1.0.68
PROJECT DETAIL:		VERSION DATE: 16/10/2020
Region: JHARKHAND URBAN LOCAL BODIES	Plot Use: Residential	
District: BOKARO	Plot SubUse: Bungalow/ Dwelling / Non Apartment	
Authority: CHAS MUNICIPAL CORPORATION	PlotNearbyReligiousStructure: NA	
Inward No: CMC/BP/0317/W34/2023	Plot/SubPlot No: 7789	
Application Type: General Proposal	North: Road Width - ROAD	
Project Type: Building Permission	South: Road Width - 4.50 MTR WIDE P.C.C. ROAD	
Nature of Development: New	East: CTS No. - KUSUM DEVI	
Location of Development Area: Old Area	West: CTS No. - NU LAND OF VENDEE	
AREA DETAILS:		SQ.MT.
AREA OF PLOT (Minimum)	(A)	201.30
NET AREA OF PLOT(Gross Plot Area - Deduction from Gross Plot area)	(A-Deductions)	201.30
Deduction for Balance Plot Area(from Gross Plot Area)		
Common Plot		14.70
Total		14.70
BALANCE AREA OF PLOT(Net Plot Area - Recreational/Amenity space)	(A-Deductions)	186.59
PLOT AREA FOR COVERAGE(Net Plot Area)	(A-Deductions)	201.30
Plot Area for FAR (Net Plot Area + RoadWidening Area)	(A-Deductions)	201.30
COVERAGE CHECK		
Permissible Coverage area (70.00 %)		140.91
Proposed Coverage Area (62.28 %)		125.36
Total Prop. Coverage Area (62.28 %)		125.36
Balance coverage area (7.72 %)		15.55
FAR CHECK		
Perm. FAR Area (1.500)		301.95
Total Perm. FAR area		301.95
Residential FAR		250.73
Proposed FAR		250.73
Total Proposed FAR Area		250.73
Consumed FAR (Factor)		1.25
Balance FAR Area		51.22
BUILT UP AREA CHECK		
Total Proposed BuiltUp Area		250.72
ARCHITECT (Regd)		AMRIT KUMAR MAHATO
ENGINEER (Regd)		
SUPERVISOR (Regd)		
OWNER (Regd)		RADHA DEVI
DEVELOPMENT AUTHORITY		LOCAL BODY

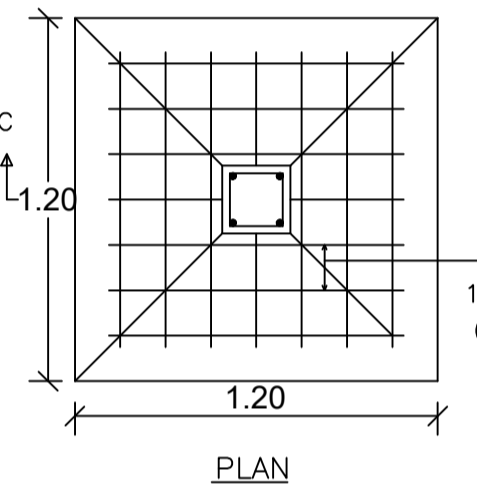
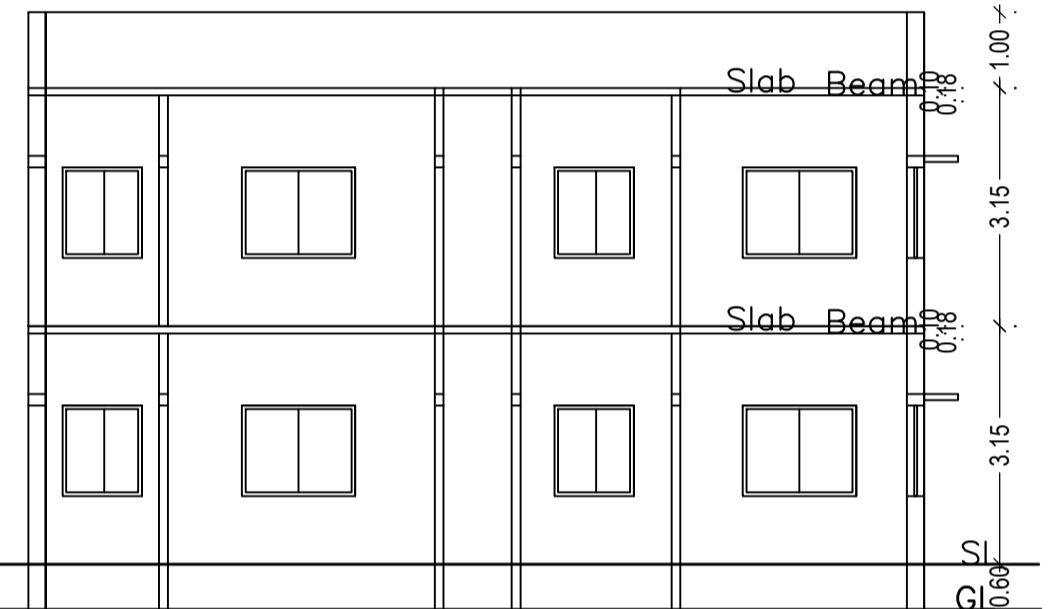
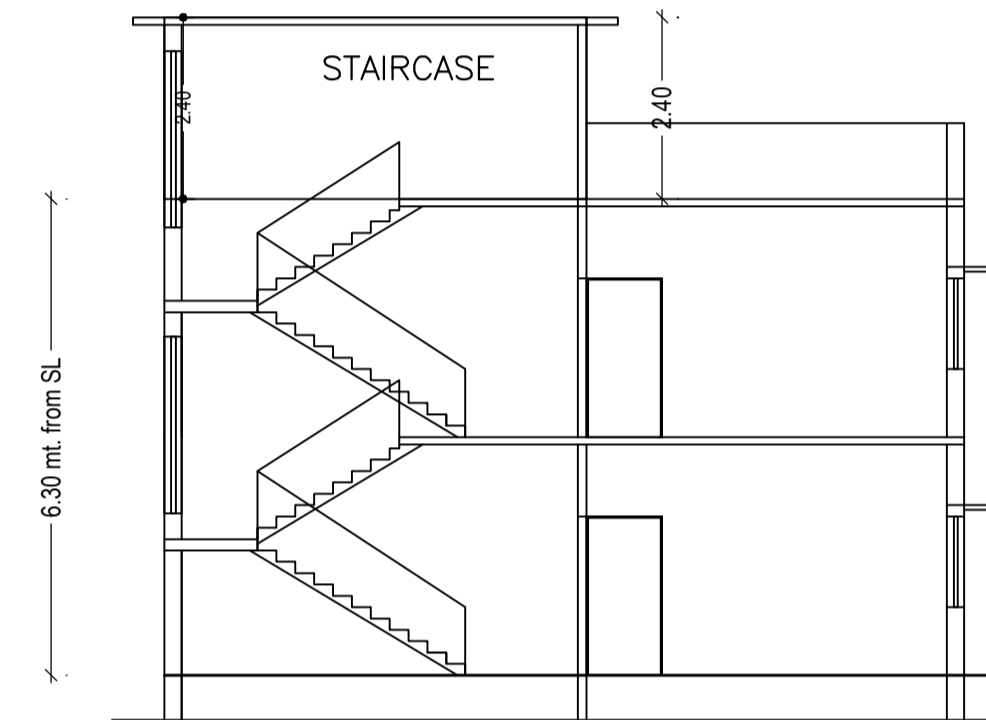
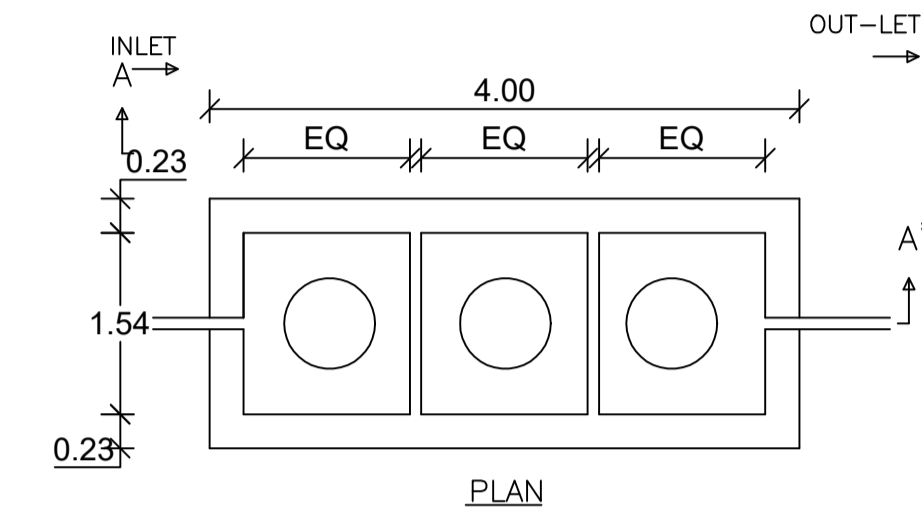
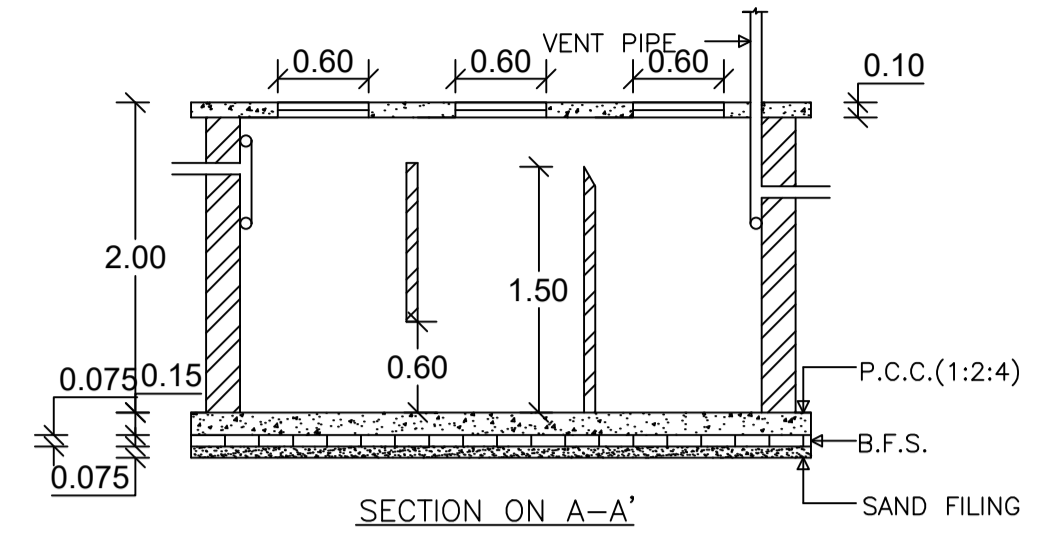
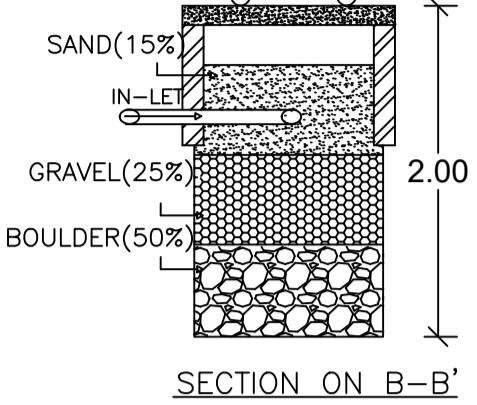
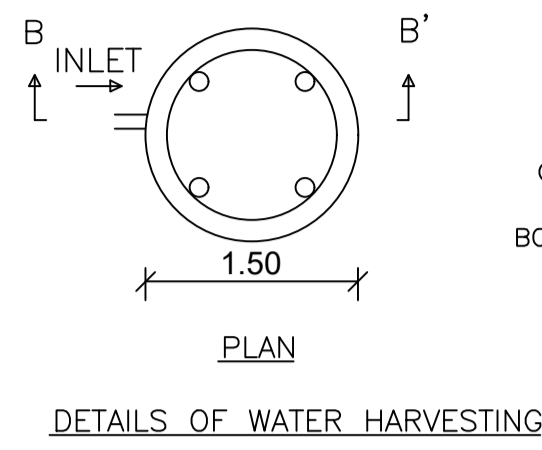
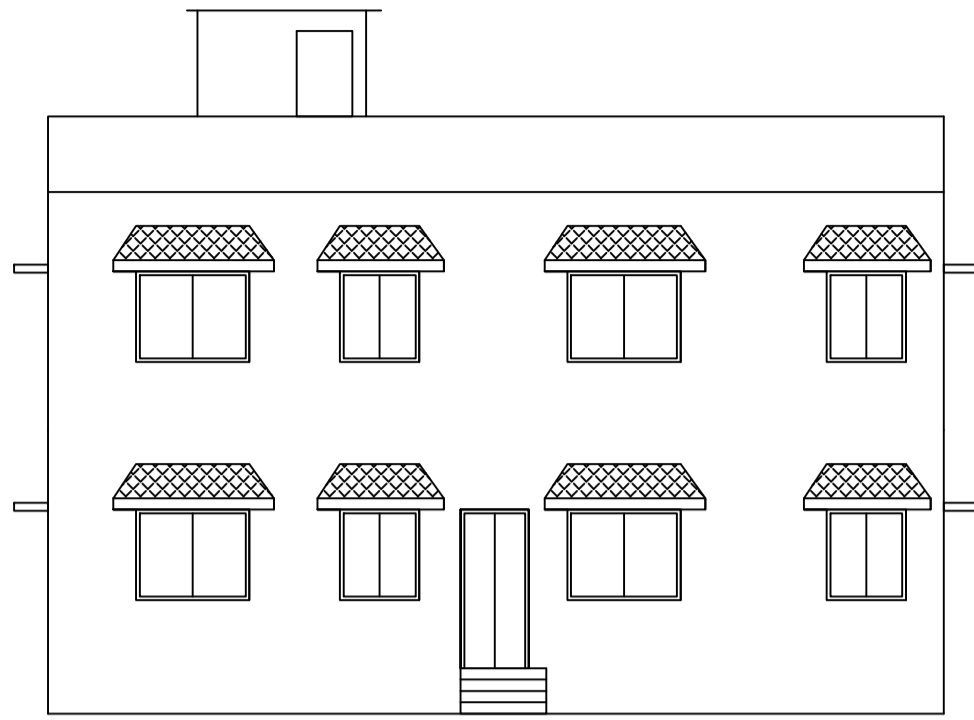
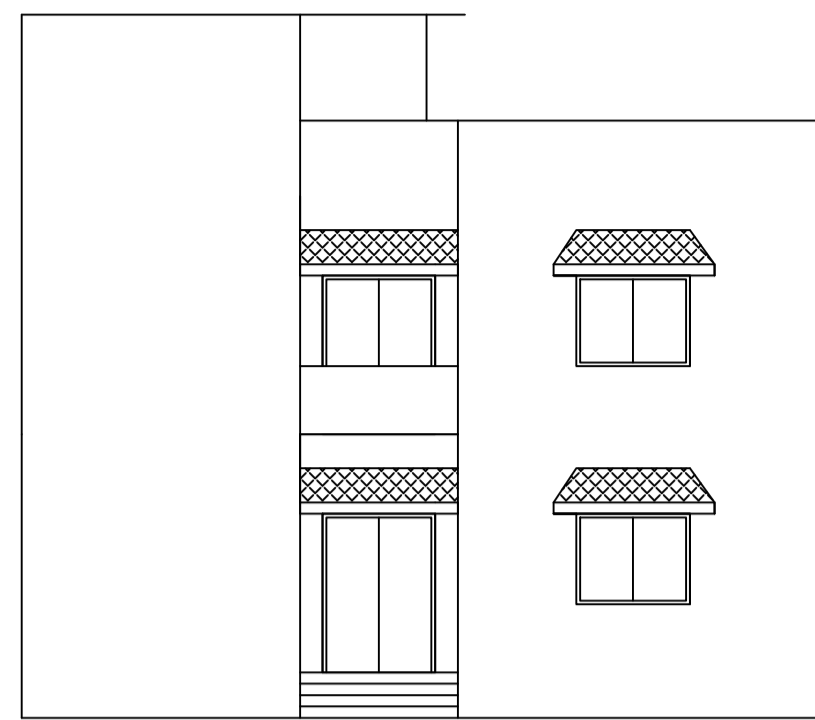
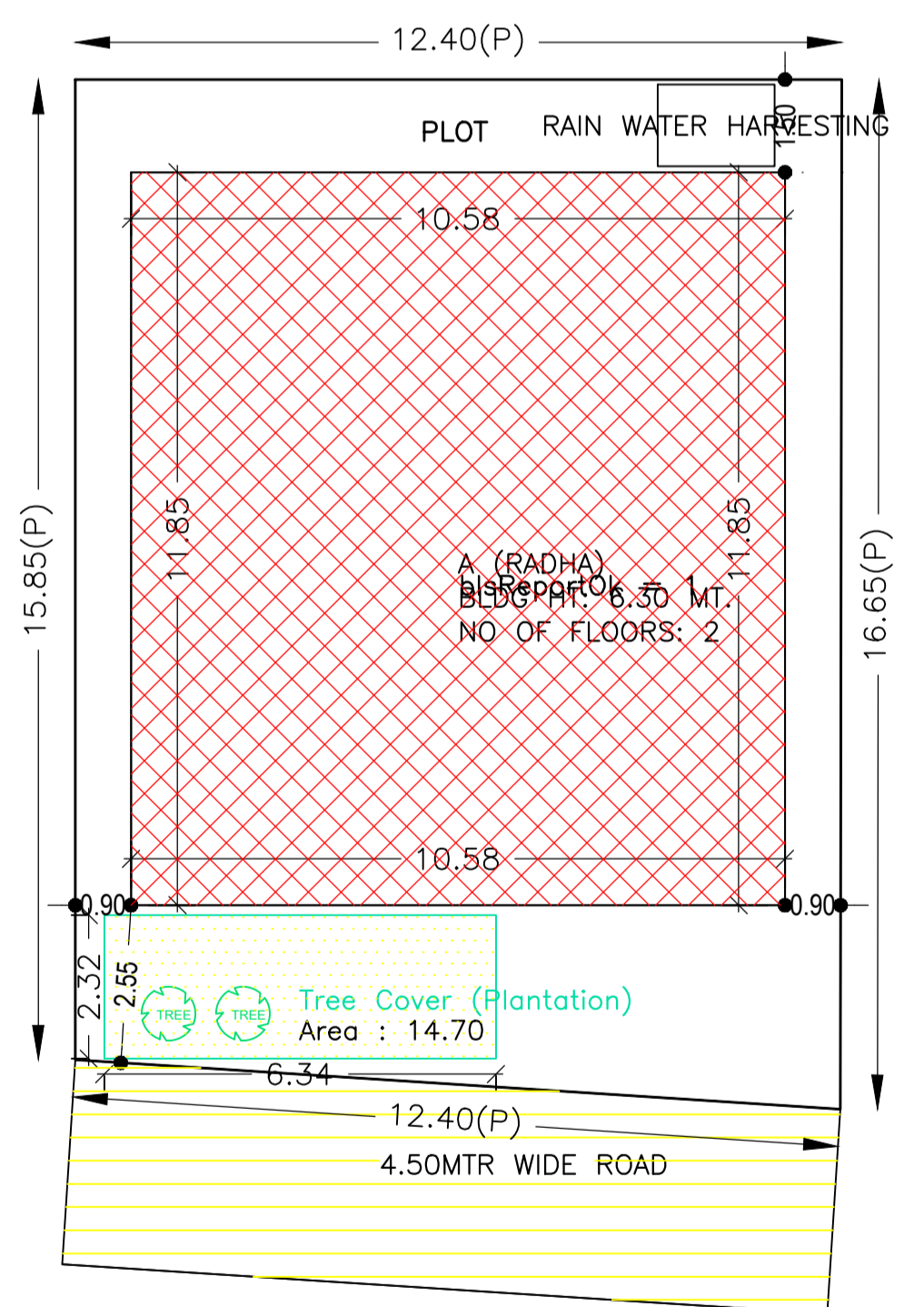
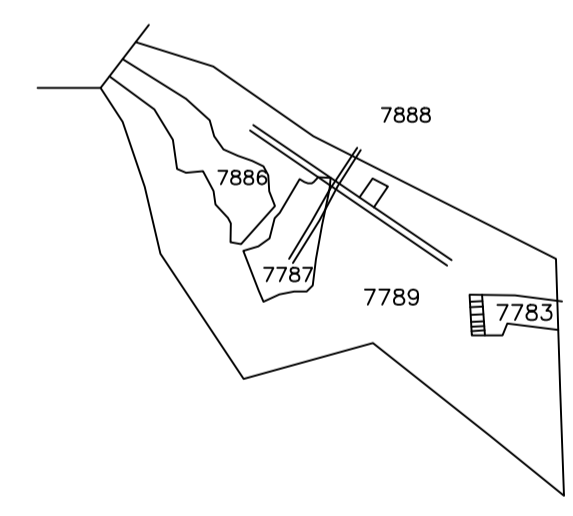
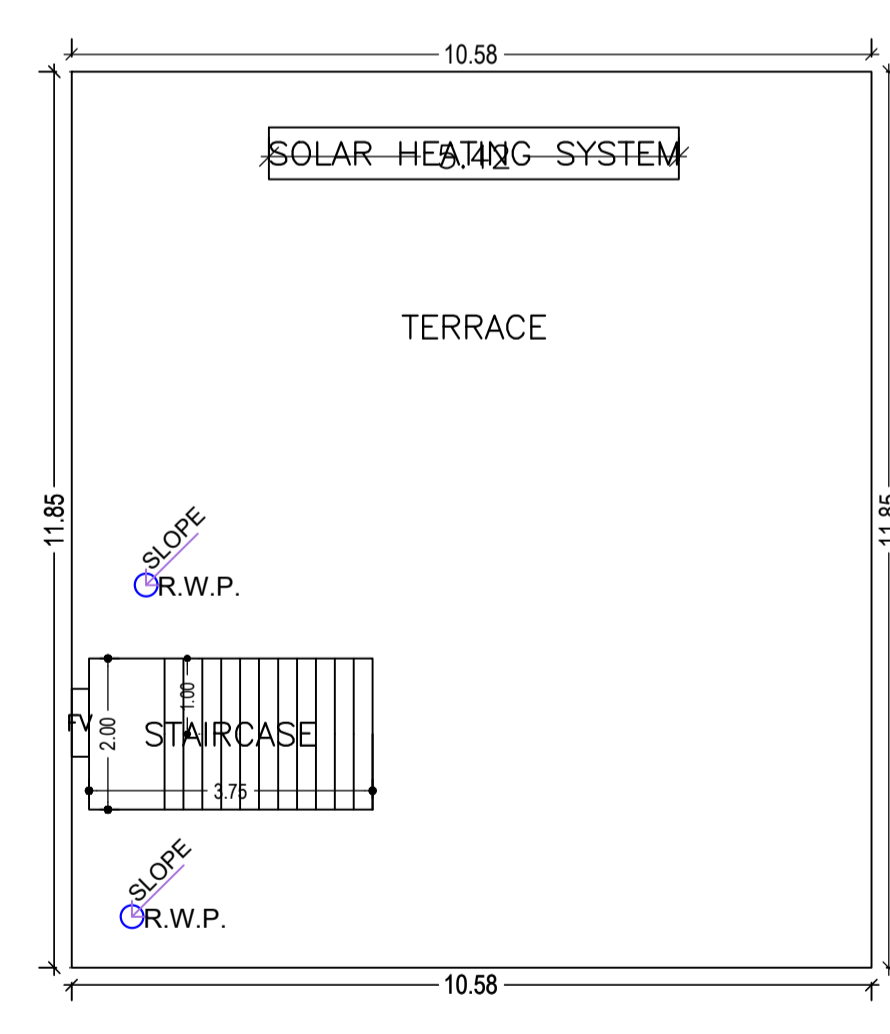
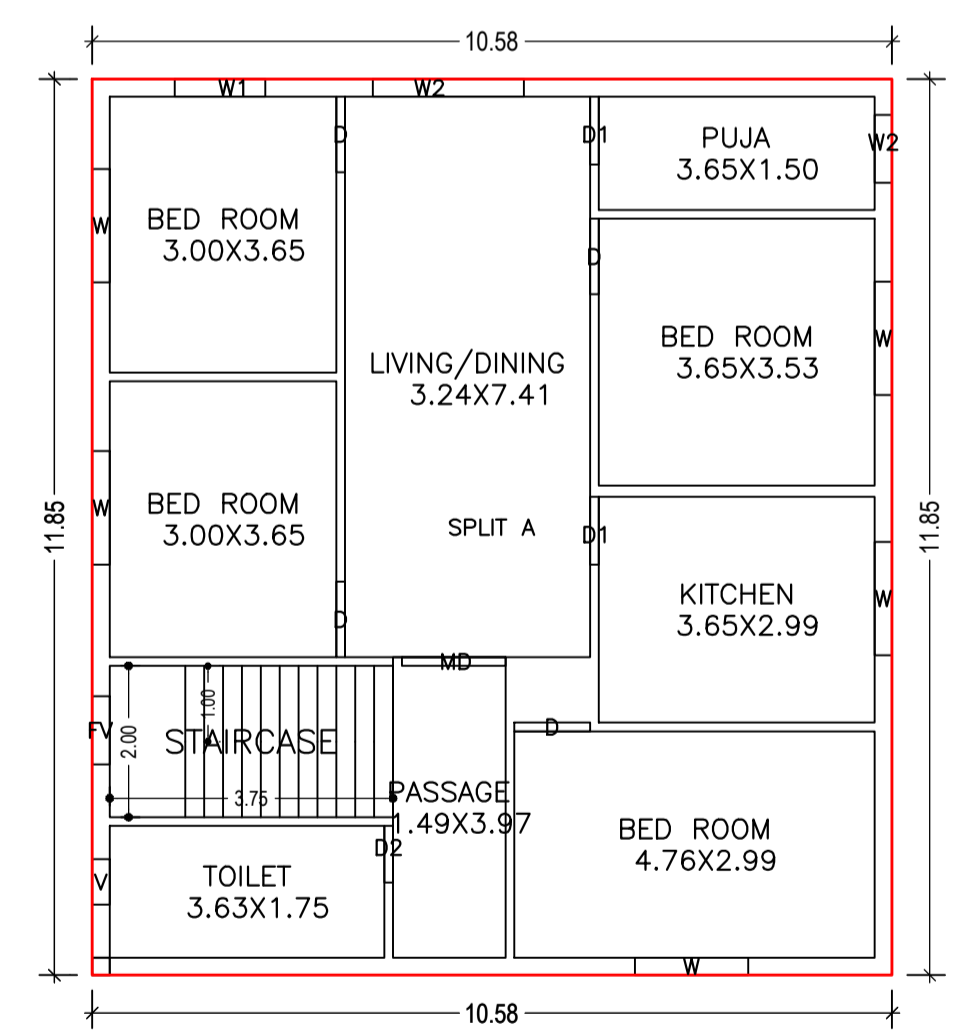
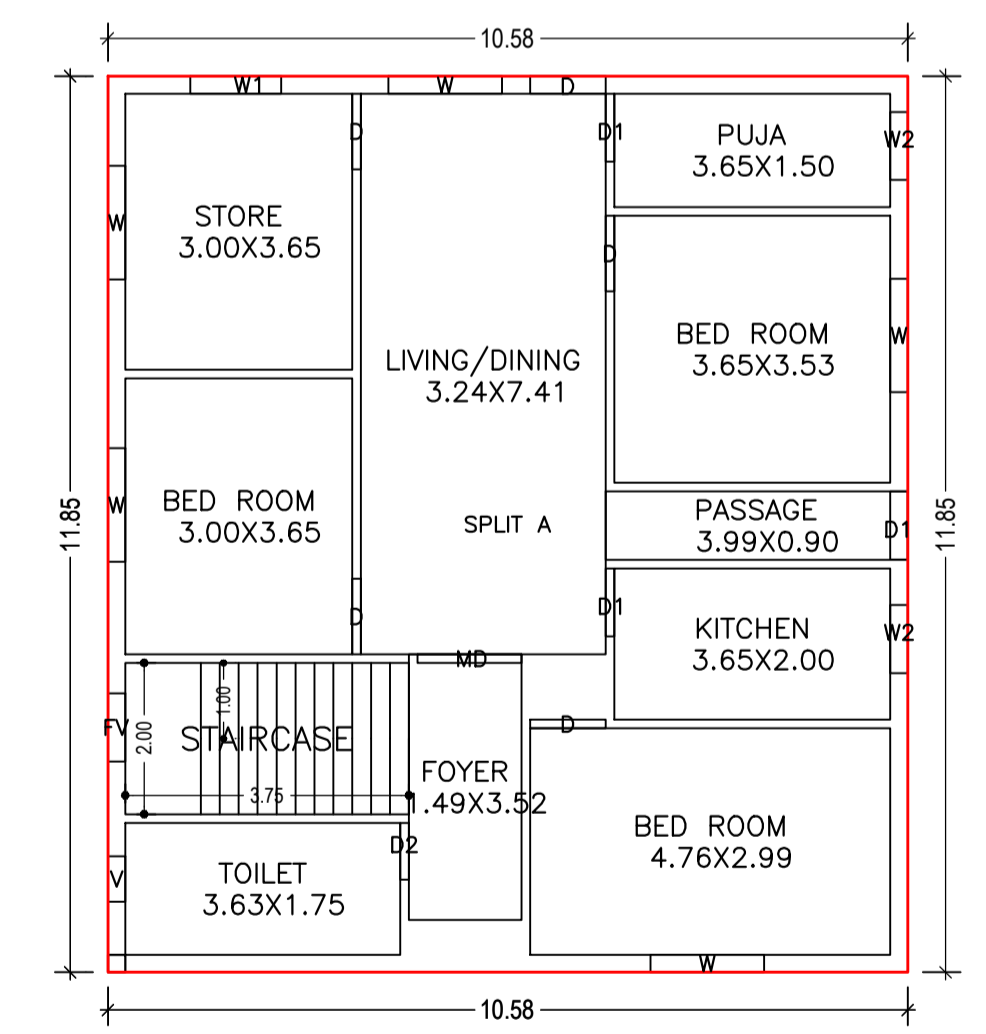

SCHEDULE OF DOOR:

BUILDING NAME	NAME	LENGTH	HEIGHT	NOS
A (RADHA)	D2	0.75	2.10	02
A (RADHA)	D1	0.90	2.10	05
A (RADHA)	D	1.00	2.10	09
A (RADHA)	MD	1.37	2.10	02

SCHEDULE OF WINDOW/VENTILATION:

BUILDING NAME	NAME	LENGTH	HEIGHT	NOS
A (RADHA)	V	0.60	0.90	02
A (RADHA)	W2	0.90	1.20	03
A (RADHA)	FV	0.90	1.50	03
A (RADHA)	W1	1.20	1.20	02
A (RADHA)	W	1.50	1.20	10
A (RADHA)	W2	2.00	1.20	01

Building :A (RADHA)

Floor Name	Total Built Up Area (Sq.mt.)	Proposed FAR Area (Sq.mt.) Resi.	Total FAR Area (Sq.mt.)	Total Consumed Additional FAR Area (Sq.mt.)	Trmt (No.)
Ground Floor	125.36	125.36	125.36	125.36	01
First Floor	125.36	125.36	125.36	125.36	00
Terrace Floor	0.00	0.00	0.00	0.00	00
Total :	250.72	250.72	250.72	250.72	01
Total Number of Same Buildings :	1				
Total :	250.72	250.72	250.72	250.72	01

Building USE/SUBUSE Details

Building Name	Building Use	Building SubUse	Building Structure
A (RADHA)	Residential	Bungalow/ Dwelling / Non Apartment	Non-Highrise

Buildingwise Floor FAR Details

Floor Name	Building Name A (RADHA)		Total	
	Proposed Built Up Area (Sq.mt.)	Proposed FAR Area (Sq.mt.)	Total Proposed Built Up Area (Sq.mt.)	Total FAR Area (Sq.mt.)
Ground Floor	125.36	125.36	125.36	125.36
First Floor	125.36	125.36	125.36	125.36
Terrace Floor	0.00	0.00	0.00	0.00
Total :	250.72	250.72	250.72	250.72

UnitBUA Table for Building :A (RADHA)

FLOOR	Name	UnitBUA Type	UnitBUA Area	Carpet Area	No. of Rooms	No. of Tenement
GROUND FLOOR PLAN	SPLIT A	FLAT	250.73	250.62	10	1
FIRST FLOOR PLAN	SPLIT A	FLAT	0.00	0.00	9	0
Total:	-	-	250.73	250.62	19	1

COLOR INDEX

PLOT BOUNDARY	Black
ABUTTING ROAD	Red
PROPOSED CONSTRUCTION	Green
COMMON PLOT	Blue
ROAD WIDENING AREA	Yellow
EXISTING (To be retained)	Light Blue
EXISTING (To be demolished)	Light Yellow

LTP NAME AND SIGNATURE	STRUCTURAL ENG'S NAME AND SIGNATURE	BUILDER NAME AND SIGNATURE	DIGITAL SIGNATURE
AMRIT KUMAR MAHATO CMC/DFTM/0004/2019			

FAR & Tenement Details (Table 4c-1)

Building	No. of Same Bldg	Total Built Up Area (Sq.mt.)	Proposed FAR Area (Sq.mt.) Resi.	Total FAR Area (Sq.mt.)	Total Consumed Additional FAR Area (Sq.mt.)	Trmt (No.)
A (RADHA)	1	250.72	250.72	250.72	250.72	01
Grand Total :	1	250.72	250.72	250.72	250.72	01