

Proposal Basic Information

Proposal File No.	CMC/BP/0042/W17/2023
Owner Name	CHAMPA DEVI
Khata No	105
Plot No	182
Village Name	Bhawanipur
Use	Residential
SubUse	Bungalow/ Dwelling / Non Apartment

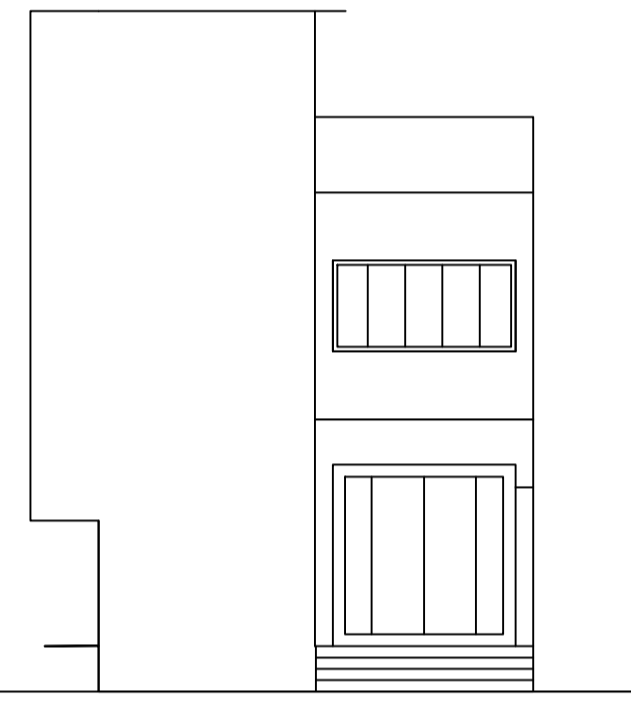

FRONT ELEVATION

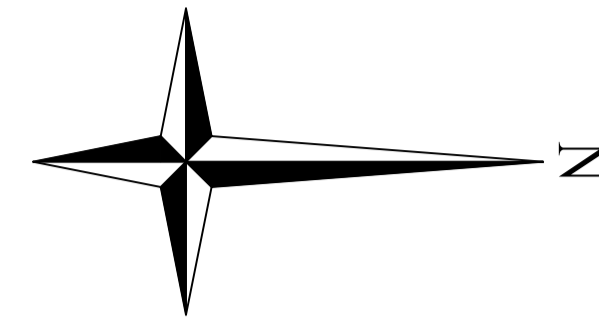
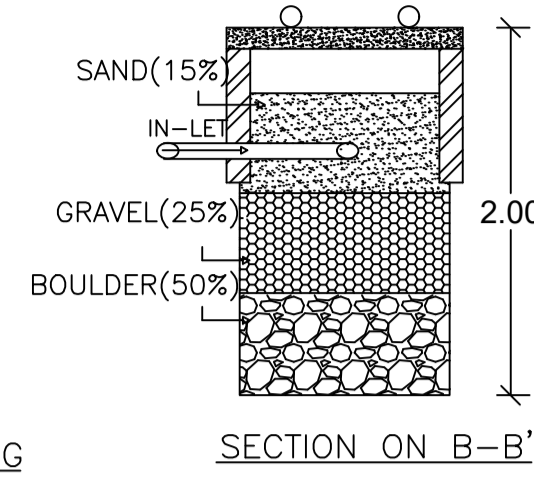
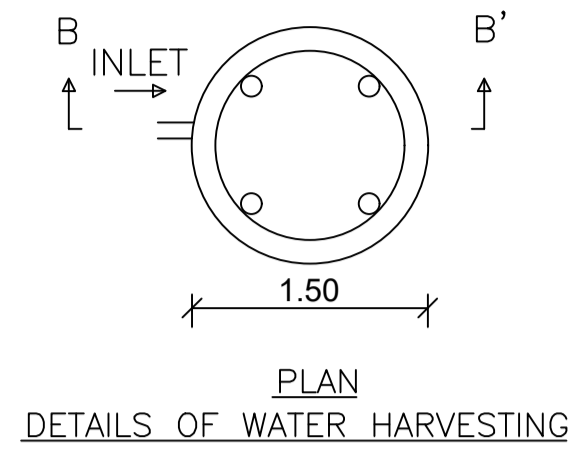
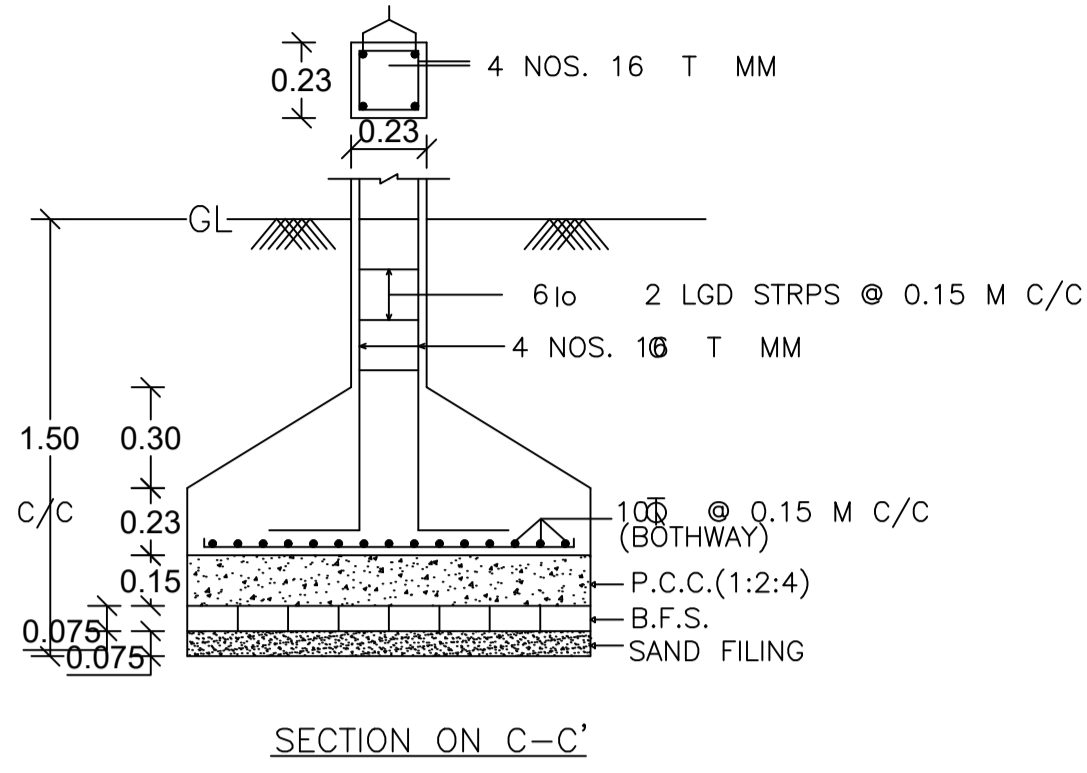
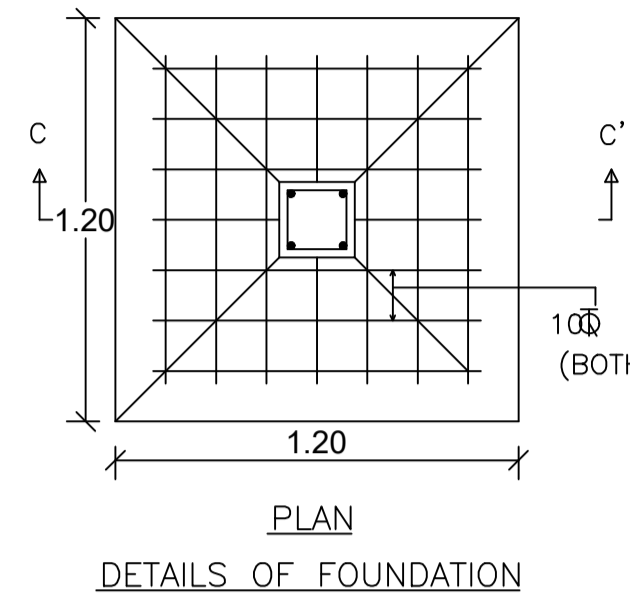
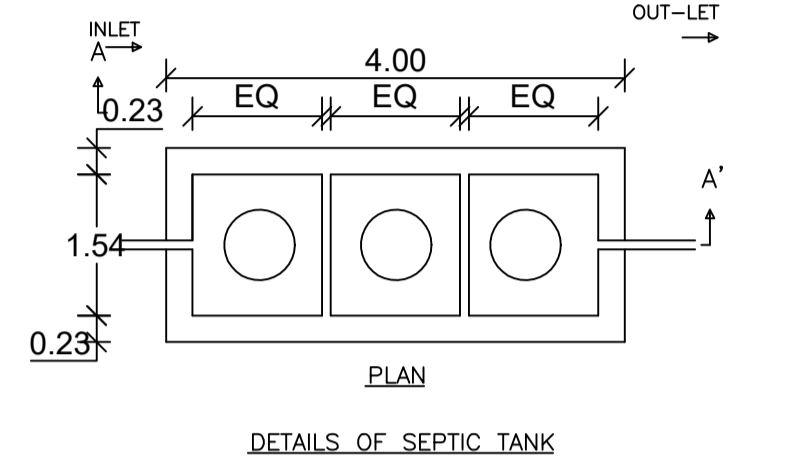
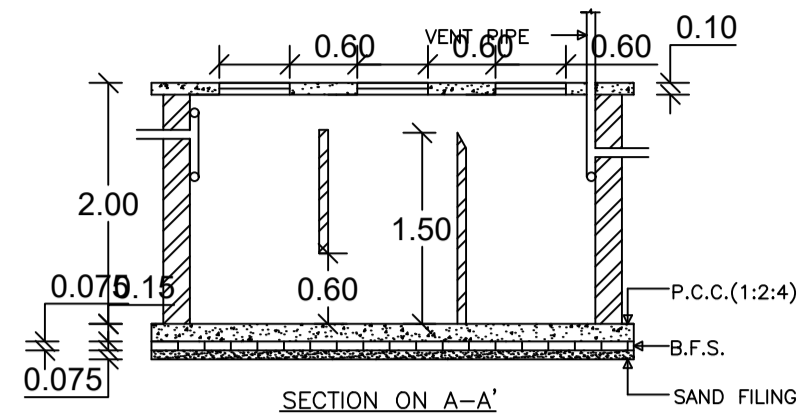
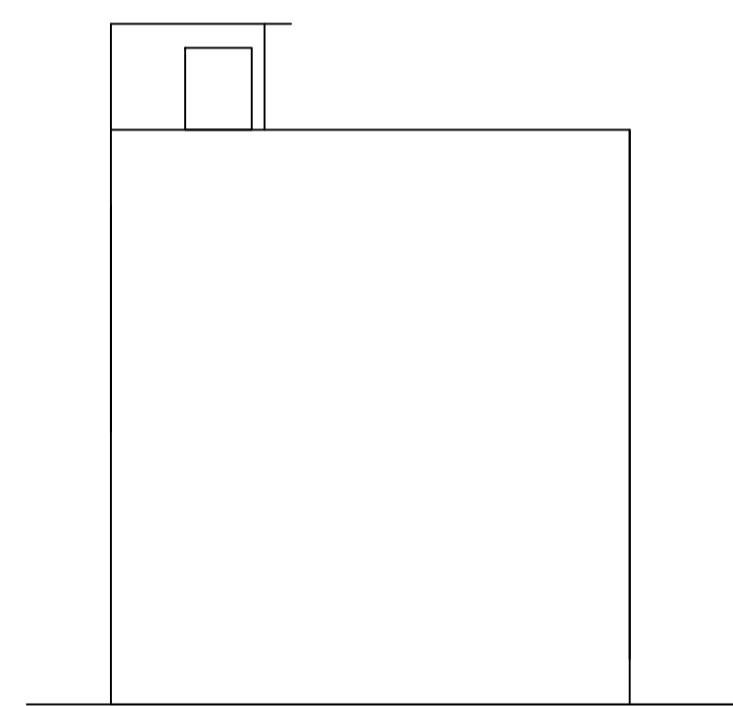

SIDE ELEVATION

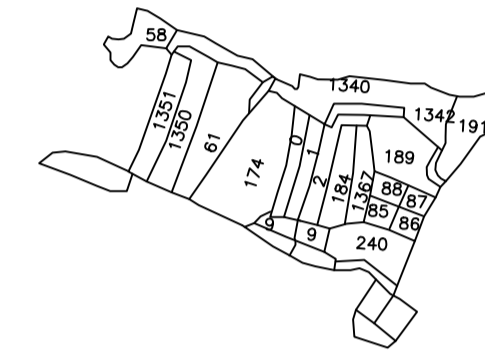
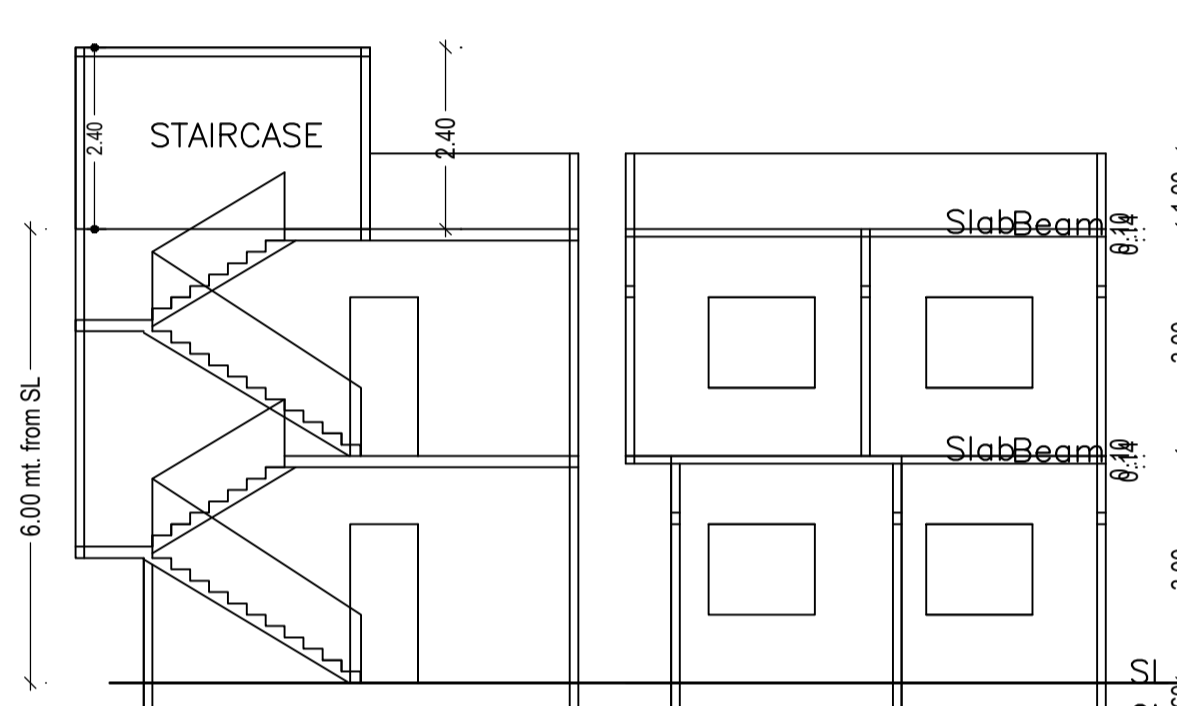

KEY MAP

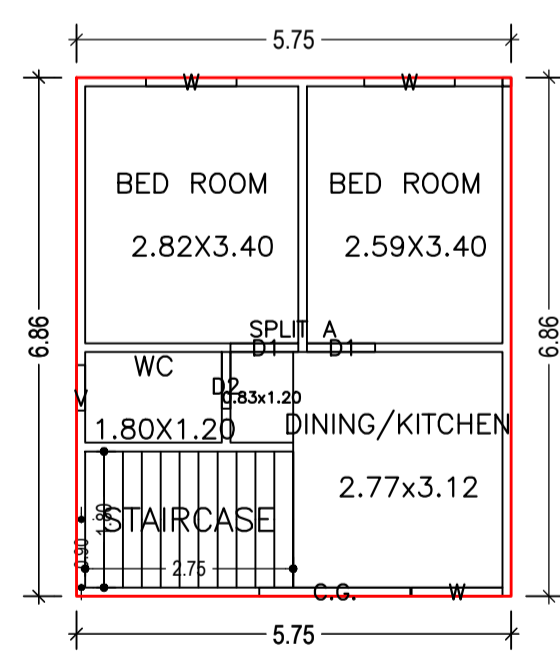
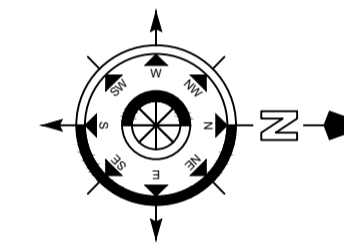

GROUND FLOOR PLAN (Proposed) (SCALE 1:100)

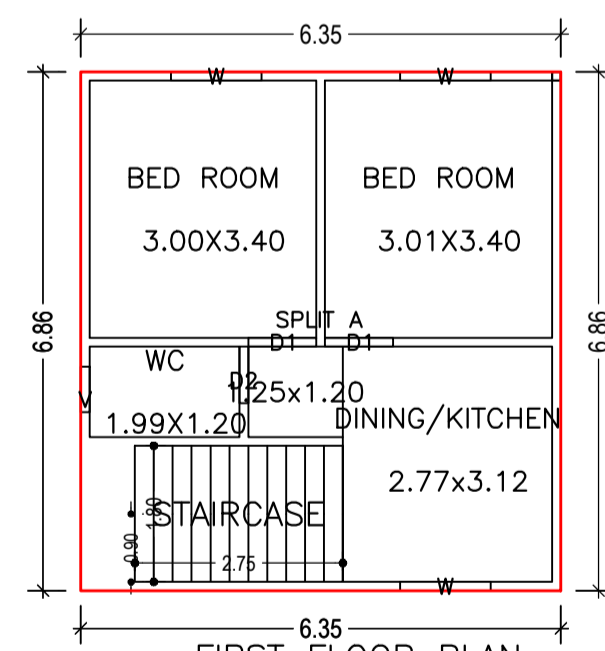

FIRST FLOOR PLAN (Proposed) (SCALE 1:100)

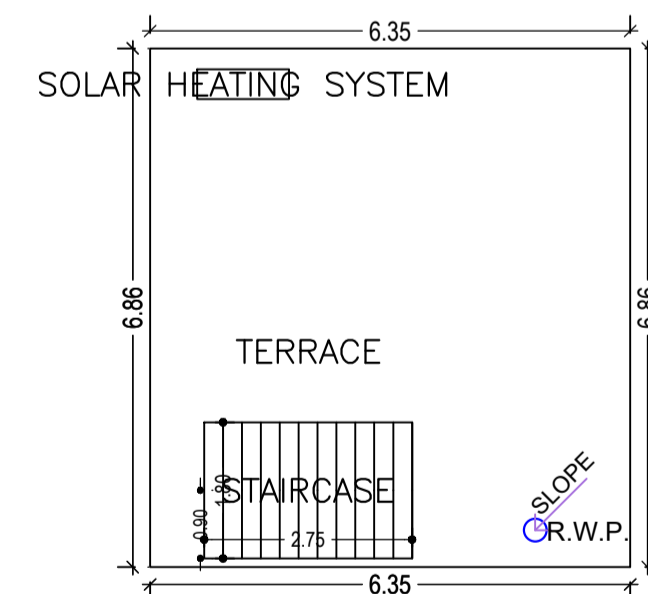

TERRACE FLOOR PLAN (SCALE 1:100)

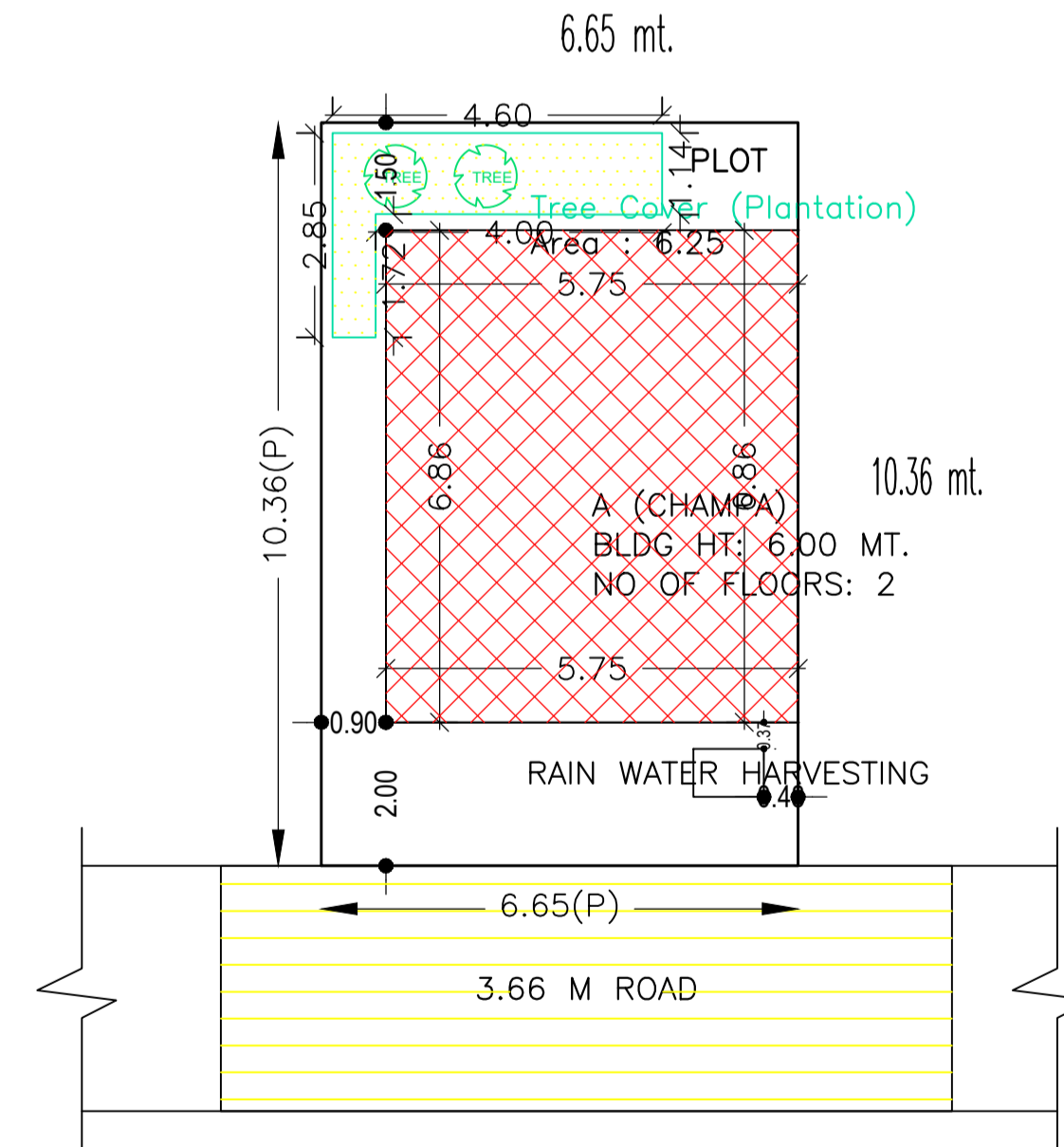

SITE PLAN

AREA STATEMENT CHAS MUNICIPAL CORPORATION	VERSION NO: 1.0.65	SQ. MT.
PROJECT DETAIL:	VERSION DATE: 16/10/2020	
Region: JHARKHAND URBAN	Plot Use: Residential	
LOCAL BODIES	Plot SubUse: Bungalow/ Dwelling / Non Apartment	
District: BOKARO	PlotNearbyReligiousStructure: NA	
Authority: CHAS MUNICIPAL CORPORATION	Plot/ SubPlot No: 182	
Inward No: CMC/BP/0042/W17/2023	North: CTS No. - SAPNA CHOUDHARY	
Application Type: General Proposal	South: CTS No. - SOBHAGI DEVI AND SAHENDRA MEHTA	
Project Type: Building Permission	East: Road Width - ROAD	
Nature of Development: New	West: CTS No. - JAGDISH CHANDRA MAHTO	
Location of Development Area: Old Area		
AREA DETAILS:		
AREA OF PLOT (Minimum)	(A)	68.89
NET AREA OF PLOT(Gross Plot Area - Deduction from Gross Plot area)	(A-Deductions)	68.89
Deduction for Balance Plot Area(from Gross Plot Area)		
Common Plot		6.25
Total		6.25
BALANCE AREA OF PLOT(Net Plot Area - Recreational/Amenity space)	(A-Deductions)	62.65
PLOT AREA FOR COVERAGE(Net Plot Area)	(A-Deductions)	68.89
Plot Area for FAR (Net Plot Area + Road Widening Area)	(A-Deductions)	68.89
COVERAGE CHECK		
Permissible Coverage area ( 70.00 % )		48.22
Proposed Coverage Area ( 57.25 % )		39.44
Total Prop. Coverage Area ( 57.25 % )		39.44
Balance coverage area ( 12.74 % )		8.78
FAR CHECK		
Perm. FAR Area ( 1.500 )		103.33
Total Perm. FAR area		103.33
Residential FAR		83.01
Proposed FAR Area		83.01
Total Proposed FAR Area		83.01
Consumed FAR (Factor)		1.20
Balance FAR Area		20.32
BUILT UP AREA CHECK		
Total Proposed BuiltUp Area		83.01
ARCHITECT (Regd)	AMRIT KUMAR MAHATO	
ENGINEER (Regd)		
SUPERVISOR (Regd)		
OWNER (Regd)	CHAMPA DEVI	
DEVELOPMENT AUTHORITY		LOCAL BODY

Building :A (CHAMPA)

Floor Name	Total Built Up Area (Sq.mt.)	Proposed FAR Area (Sq.mt.) Resi.	Total FAR Area (Sq.mt.)	Total Consumed Additional FAR Area (Sq.mt.)	Tnmt (No.)
Ground Floor	39.45	39.45	39.45	39.45	01
First Floor	43.56	43.56	43.56	43.56	00
Terrace Floor	0.00	0.00	0.00	0.00	00
Total :	83.01	83.01	83.01	83.01	01
Total Number of Same Buildings :	1				
Total :	83.01	83.01	83.01	83.01	01

SCHEDULE OF DOOR:

BUILDING NAME	NAME	LENGTH	HEIGHT	NOS
A (CHAMPA)	D2	0.75	2.10	02
A (CHAMPA)	D1	0.90	2.10	04
A (CHAMPA)	C.G.	2.00	2.10	01

SCHEDULE OF WINDOW/VENTILATION:

BUILDING NAME	NAME	LENGTH	HEIGHT	NOS
A (CHAMPA)	V	0.60	1.20	02
A (CHAMPA)	W	1.20	1.20	06

FAR & Tenement Details (Table 4c-1)

Building	No of Same Bldg	Total Built Up Area (Sq.mt.)	Proposed FAR Area (Sq.mt.) Resi.	Total FAR Area (Sq.mt.)	Total Consumed Additional FAR Area (Sq.mt.)	Tnmt (No.)
A (CHAMPA)	1	83.01	83.01	83.01	83.01	01
Grand Total :	1	83.01	83.01	83.01	83.01	01

Building USE/SUBUSE Details

Building Name	Building Use	Building SubUse	Building Structure
A (CHAMPA)	Residential	Bungalow/ Dwelling / Non Apartment	Non-Highrise

Buildingwise Floor FAR Details

Floor Name	Building Name A (CHAMPA)		Total	
	Proposed Built Up Area (Sq.mt.)	Proposed FAR Area (Sq.mt.)	Total Proposed Built Up Area (Sq.mt.)	Total FAR Area (Sq.mt.)
Ground Floor	39.45	39.45	39.45	39.45
First Floor	43.56	43.56	43.56	43.56
Terrace Floor	0.00	0.00	0.00	0.00
Total :	83.01	83.01	83.01	83.01

LTP NAME AND SIGNATURE	STRUCTURAL ENG'S NAME AND SIGNATURE	BUILDER NAME AND SIGNATURE	DIGITAL SIGNATURE
AMRIT KUMAR MAHATO CMC/DFTM/0004/2019			

COLOR INDEX	
PLOT BOUNDARY	
ABUTTING ROAD	
PROPOSED CONSTRUCTION	
COMMON PLOT	
ROAD WIDENING AREA	
EXISTING (To be retained)	
EXISTING (To be demolished)	

UnitBUA Table for Building :A (CHAMPA)

FLOOR	Name	UnitBUA Type	UnitBUA Area	Carpet Area	No. of Rooms	No. of Tenement
FIRST FLOOR PLAN	SPLIT A	FLAT	0.00	0.00	4	0
GROUND FLOOR PLAN	SPLIT A	FLAT	83.01	82.98	4	1
Total:	-	-	83.01	82.98	8	1