

Proposal Basic Information	
Proposal File No.	CMC/BP/0067/W07/2023
Owner Name	SAMEER KUMAR
Khata No	632
Plot No	3148
Village Name	Chas
Use	Residential
SubUse	Bungalow/ Dwelling / Non Apartment

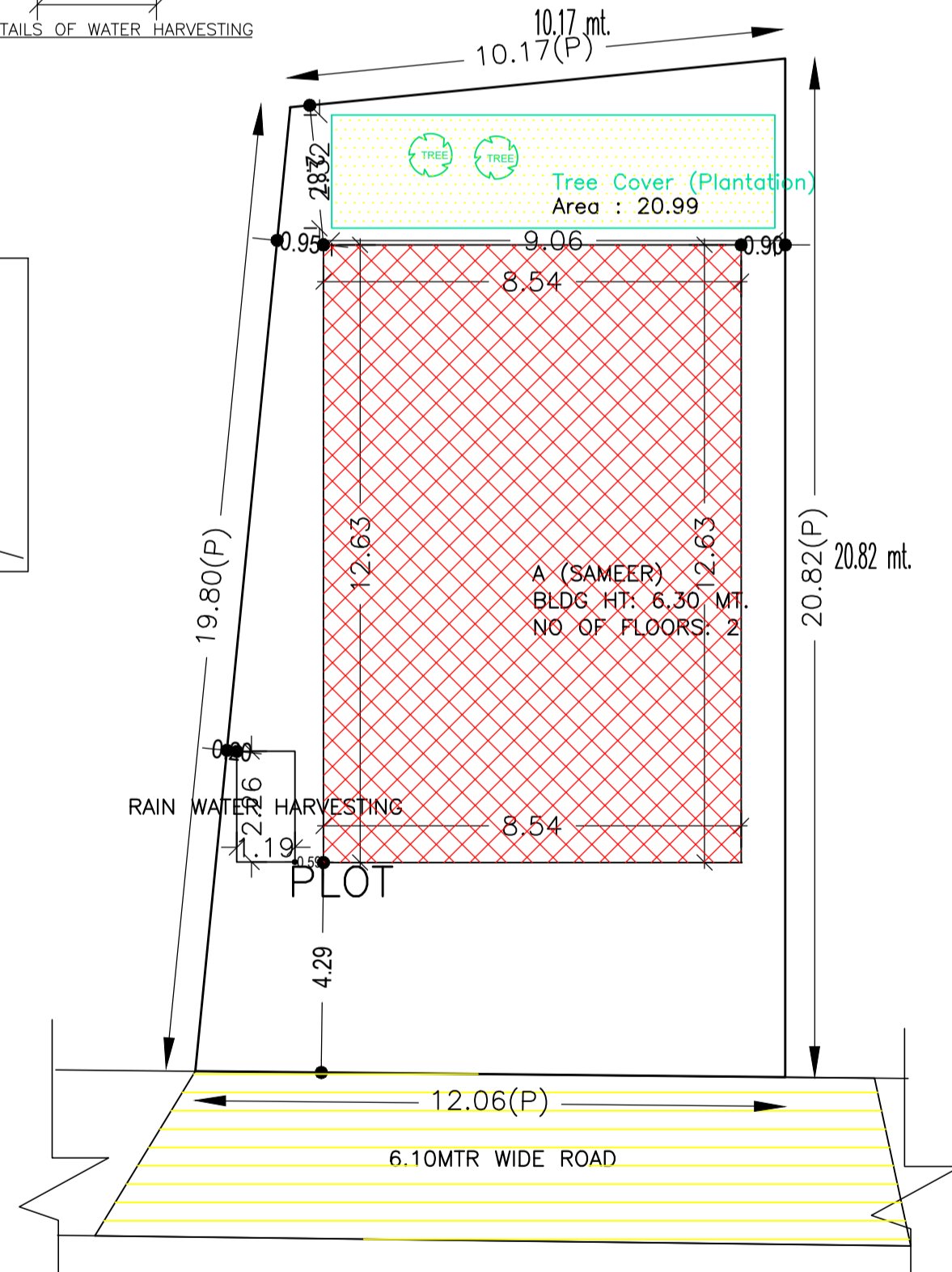
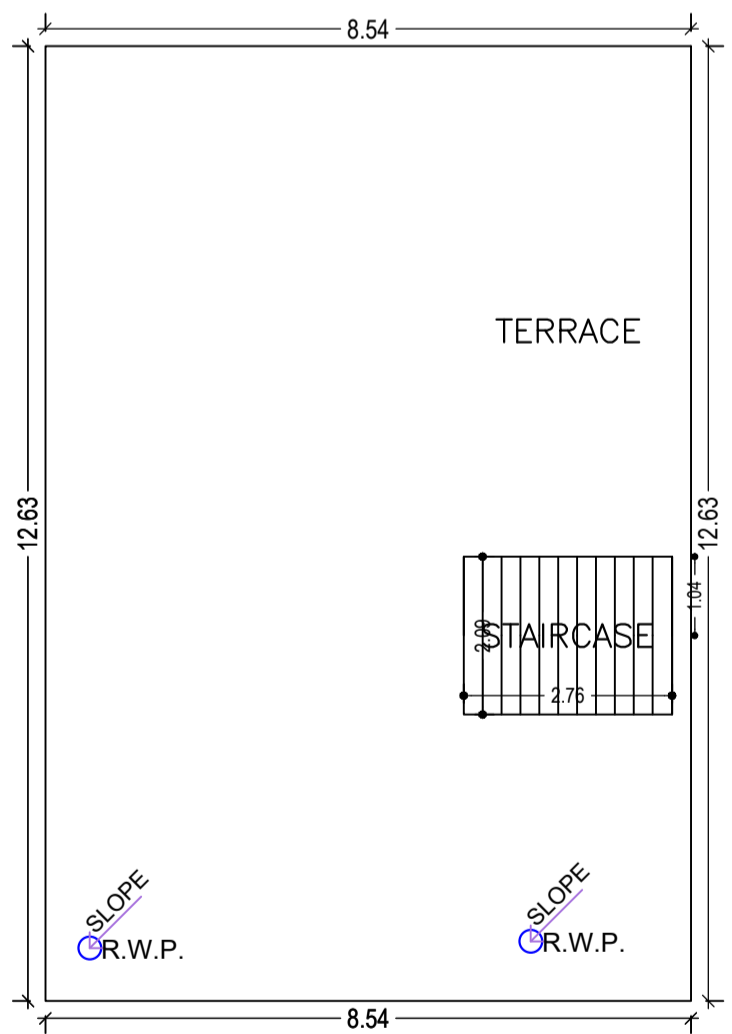
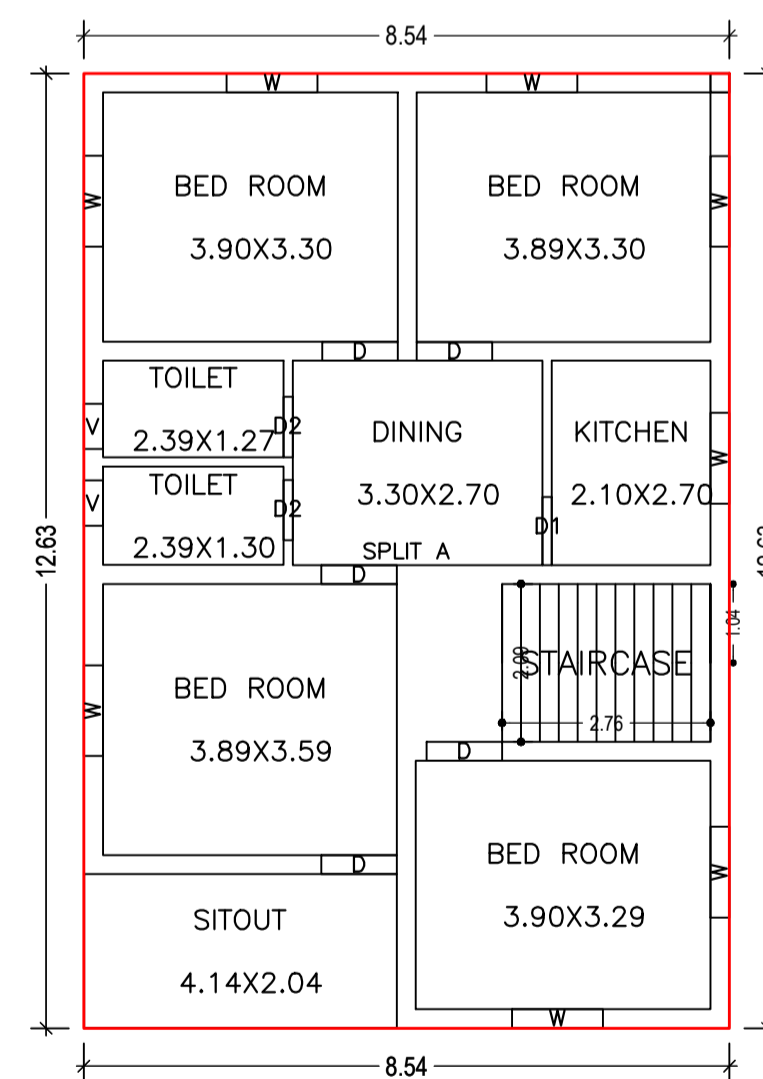
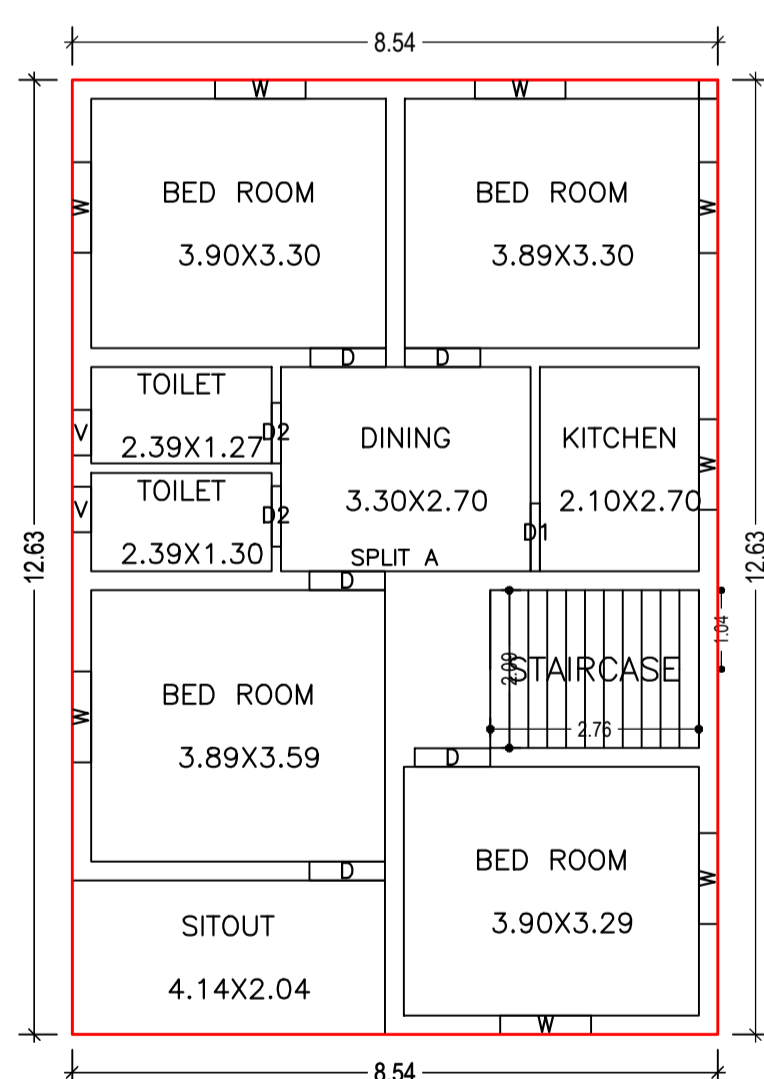
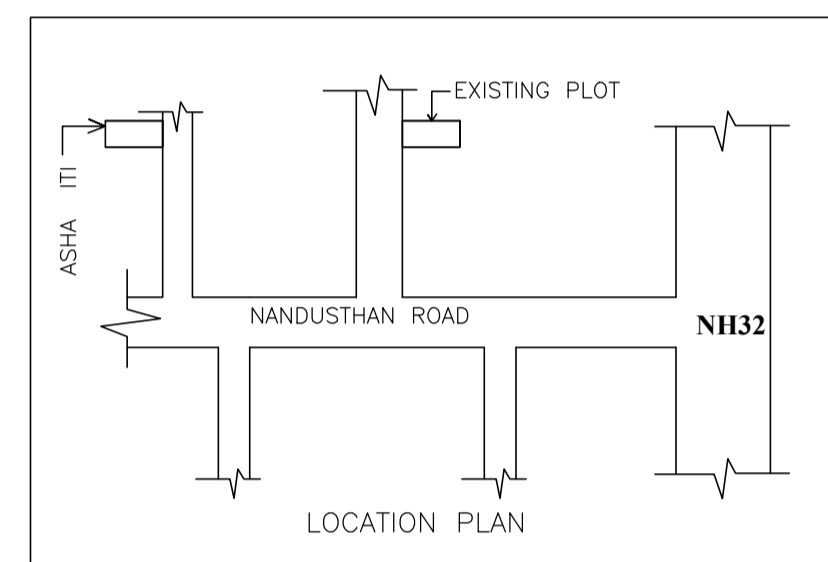
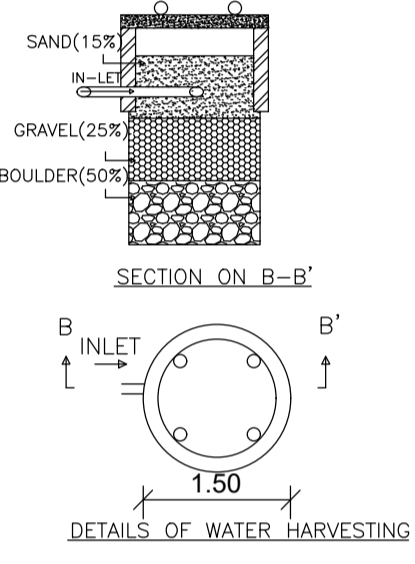
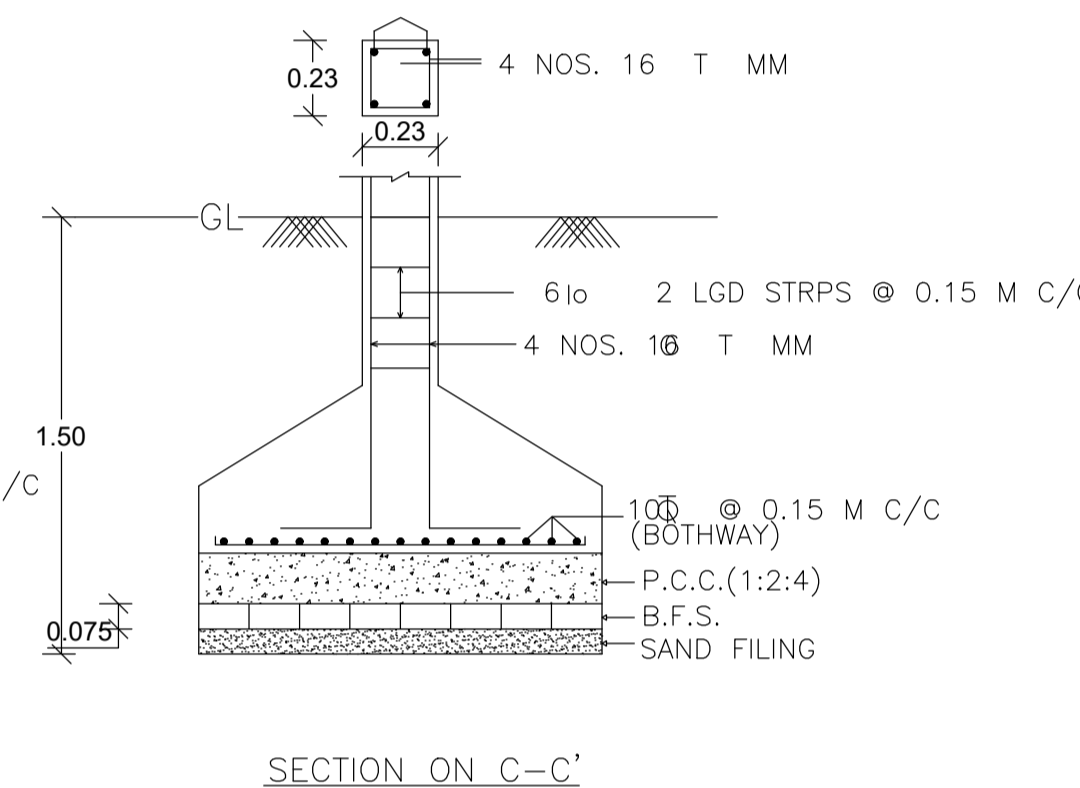
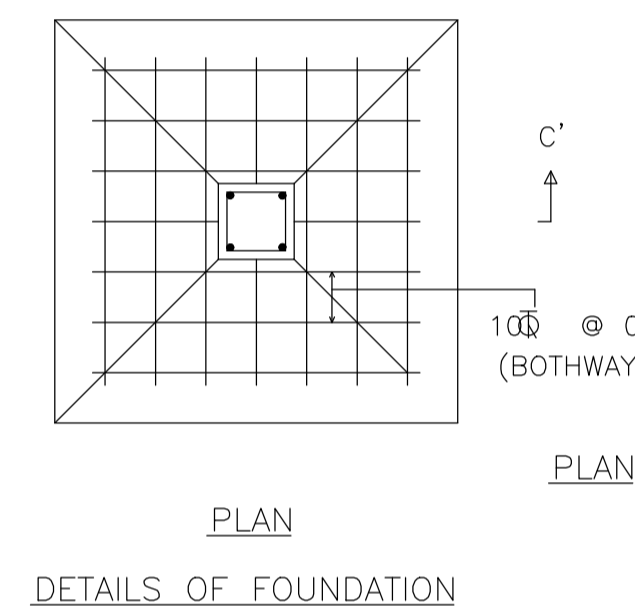
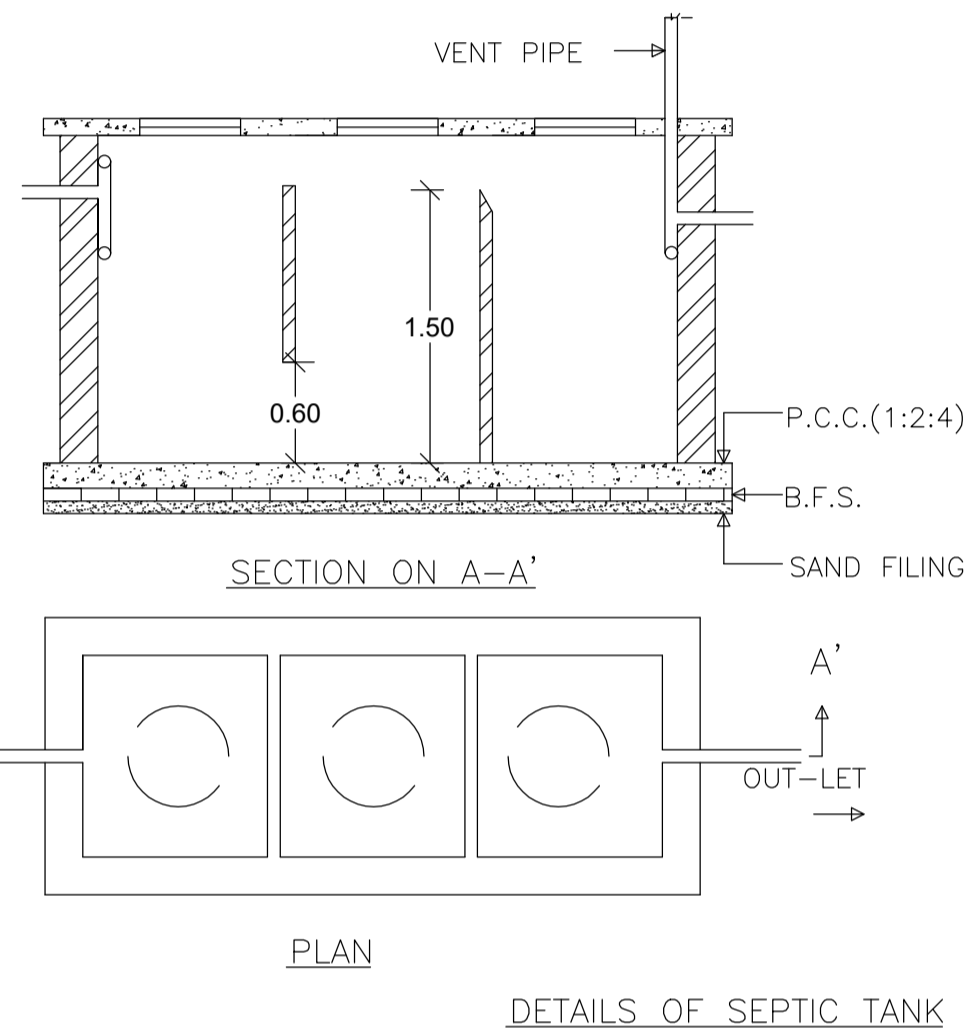
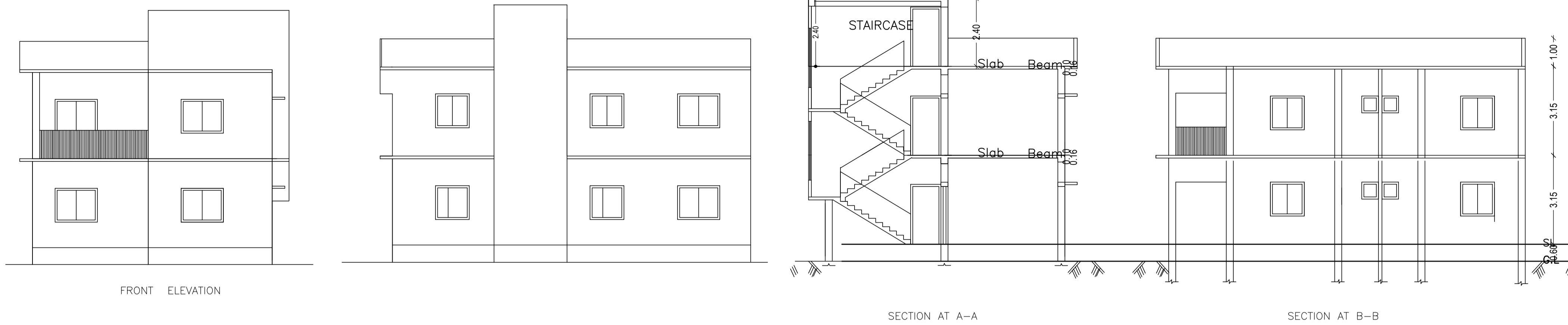
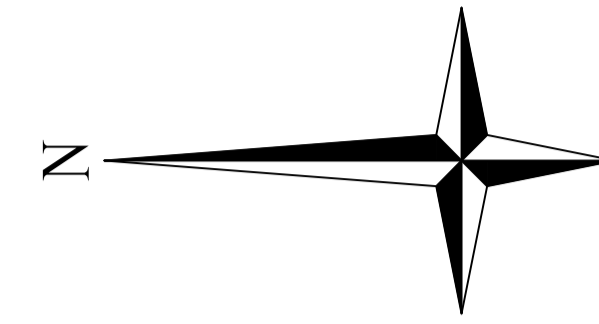

AREA STATEMENT CHAS MUNICIPAL CORPORATION		VERSION NO. : 1.0.65
PROJECT DETAIL:		VERSION DATE: 16/10/2020
Region: JHARKHAND URBAN LOCAL BODIES	Plot Use: Residential	
District: BOKARO	Plot SubUse: Bungalow/ Dwelling / Non Apartment	
Authority: CHAS MUNICIPAL CORPORATION	PlotNearby/ReligiousStructure: NA	
Inward No: CMC/BP/0067/W07/2023	Plot/SubPlot No: 3148	
Application Type: General Proposal	North: Survey No. - SURVEY PLOT NO.- 3147,3149	
Project Type: Building Permission	South: Plot No. - SURVEY PLOT NO.- 3149	
Nature of Development: New	East: Plot No. - SURVEY PLOT NO.- 3147	
Location of Development Area: Old Area	West: Road Width - ROAD	
AREA OF PLOT (Minimum)	(A)	SQ.MT. 224.36
NET AREA OF PLOT(Gross Plot Area - Deduction from Gross Plot area)	(A-Deductions)	224.36
Deduction for Balance Plot Area(from Gross Plot Area)		
Common Plot		20.99
Total		20.99
BALANCE AREA OF PLOT(Net Plot Area - Recreational/Amenity space)	(A-Deductions)	203.37
PLOT AREA FOR COVERAGE(Net Plot Area)	(A-Deductions)	224.36
Plot Area for FAR (Net Plot Area + RoadWidening Area)	(A-Deductions)	224.36
COVERAGE CHECK		
Permissible Coverage area (70.00 %)		157.05
Proposed Coverage Area (48.06 %)		107.82
Total Prop. Coverage Area (48.06 %)		107.82
Balance coverage area (21.94 %)		49.23
FAR CHECK		
Perm. FAR Area (2.500)		560.90
Total Perm. FAR area		560.90
Residential FAR		215.64
Proposed FAR Area		215.64
Total Proposed FAR Area		215.64
Consumed FAR (Factor)		0.96
Balance FAR Area		345.26
BUILT UP AREA CHECK		
Total Proposed BuiltUp Area		215.64
ARCHITECT (Regd)		AMRIT KUMAR MAHATO
ENGINEER (Regd)		
SUPERVISOR (Regd)		
OWNER (Regd)		SAMEER KUMAR
DEVELOPMENT AUTHORITY		LOCAL BODY

Buildingwise Floor FAR Details				
Floor Name	Building Name A (SAMEER)		Total	
	Proposed Built Up Area (Sq.mt.)	Proposed FAR Area (Sq.mt.)	Total Proposed Built Up Area (Sq.mt.)	Total FAR Area (Sq.mt.)
Ground Floor	107.82	107.82	107.82	107.82
First Floor	107.82	107.82	107.82	107.82
Terrace Floor	0.00	0.00	0.00	0.00
Total :	215.64	215.64	215.64	215.64

Building :A (SAMEER)					
Floor Name	Total Built Up Area (Sq.mt.)	Proposed FAR Area (Sq.mt.) Resi.	Total FAR Area (Sq.mt.)	Total Consumed Additional FAR Area (Sq.mt.)	Tnmt (No.)
Ground Floor	107.82	107.82	107.82	107.82	01
First Floor	107.82	107.82	107.82	107.82	00
Terrace Floor	0.00	0.00	0.00	0.00	00
Total :	215.64	215.64	215.64	215.64	01
Total Number of Same Buildings :	1				
Total :	215.64	215.64	215.64	215.64	01

SCHEDULE OF DOOR:				
BUILDING NAME	NAME	LENGTH	HEIGHT	NOS
A (SAMEER)	D2	0.80	2.10	04
A (SAMEER)	D1	0.90	2.10	02
A (SAMEER)	D	1.00	2.10	10

SCHEDULE OF WINDOW/VENTILATION:				
BUILDING NAME	NAME	LENGTH	HEIGHT	NOS
A (SAMEER)	V	0.60	1.20	04
A (SAMEER)	W	1.20	1.20	16

FAR & Tenement Details (Table 4c-1)

Building	No. of Same Bldg	Total Built Up Area (Sq.mt.)	Proposed FAR Area (Sq.mt.) Resi.	Total FAR Area (Sq.mt.)	Total Consumed Additional FAR Area (Sq.mt.)	Tnmt (No.)
A (SAMEER)	1	215.64	215.64	215.64	215.64	01
Grand Total :	1	215.64	215.64	215.64	215.64	01

UnitBUA Table for Building :A (SAMEER)

FLOOR	Name	UnitBUA Type	UnitBUA Area	Carpet Area	No. of Rooms	No. of Tenement
GROUND FLOOR PLAN	SPLIT A	FLAT	215.64	215.51	9	1
FIRST FLOOR PLAN	SPLIT A	FLAT	0.00	0.00	9	0
Total:	-	-	215.64	215.51	18	1

COLOR INDEX	
PLOT BOUNDARY	Black
ABUTTING ROAD	Green
PROPOSED CONSTRUCTION	Red
COMMON PLOT	Yellow
ROAD WIDENING AREA	Blue
EXISTING (To be retained)	Light Blue
EXISTING (To be demolished)	Dark Blue

LTP NAME AND SIGNATURE	STRUCTURAL ENG'S NAME AND SIGNATURE	BUILDER NAME AND SIGNATURE	DIGITAL SIGNATURE
AMRIT KUMAR MAHATO CMC/DFTMN/004/2019			

Building USE/SUBUSE Details

Building Name	Building Use	Building SubUse	Building Structure
A (SAMEER)	Residential	Bungalow/ Dwelling / Non Apartment	Non-Highrise