

Proposal Basic Information

Proposal File No.	CMC/BP/0057/W02/2023
Owner Name	PRITI KUMARI DEVI
Khata No	188
Plot No	684,686
Village Name	Chas
Use	Residential
SubUse	Bungalow/ Dwelling / Non Apartment

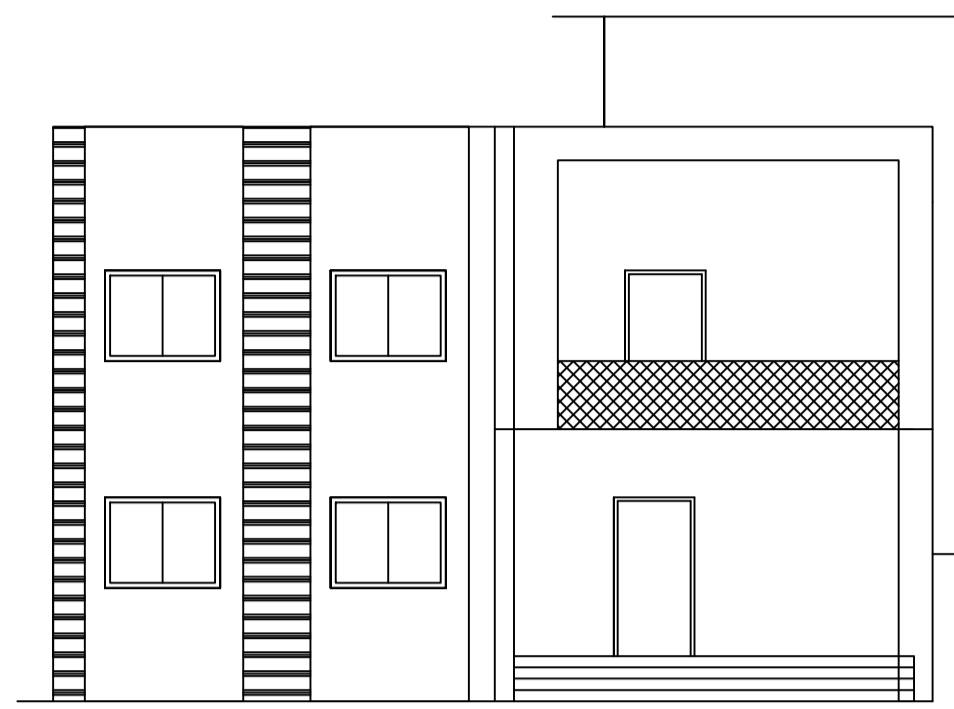

FRONT ELEVATION

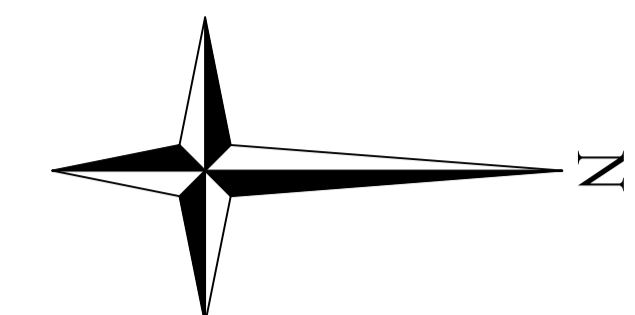
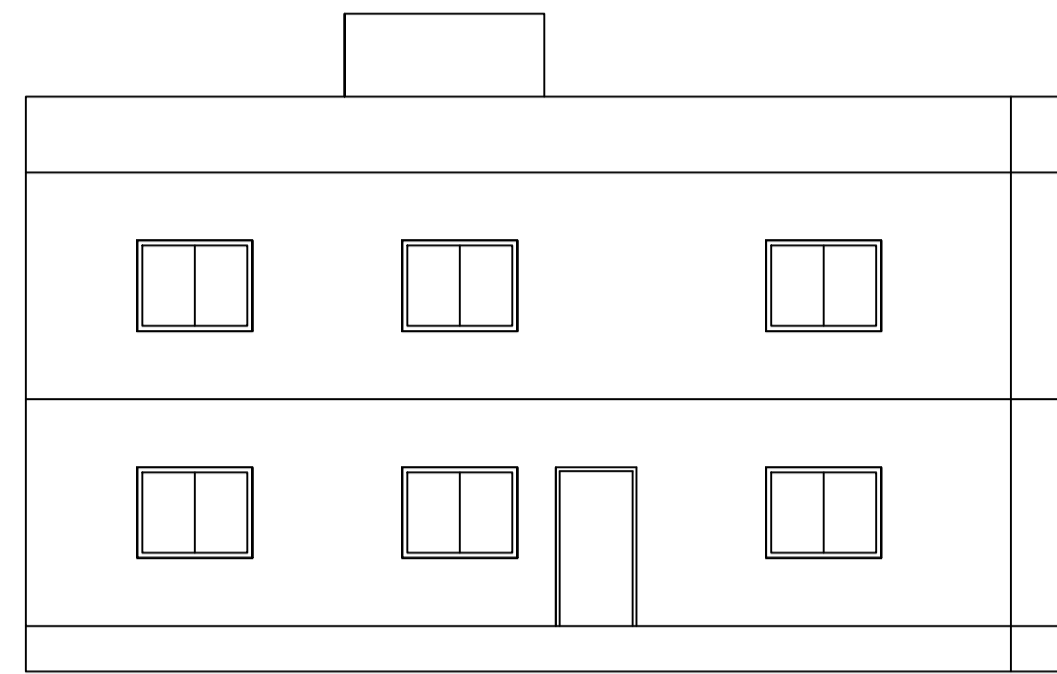

SIDE ELEVATION

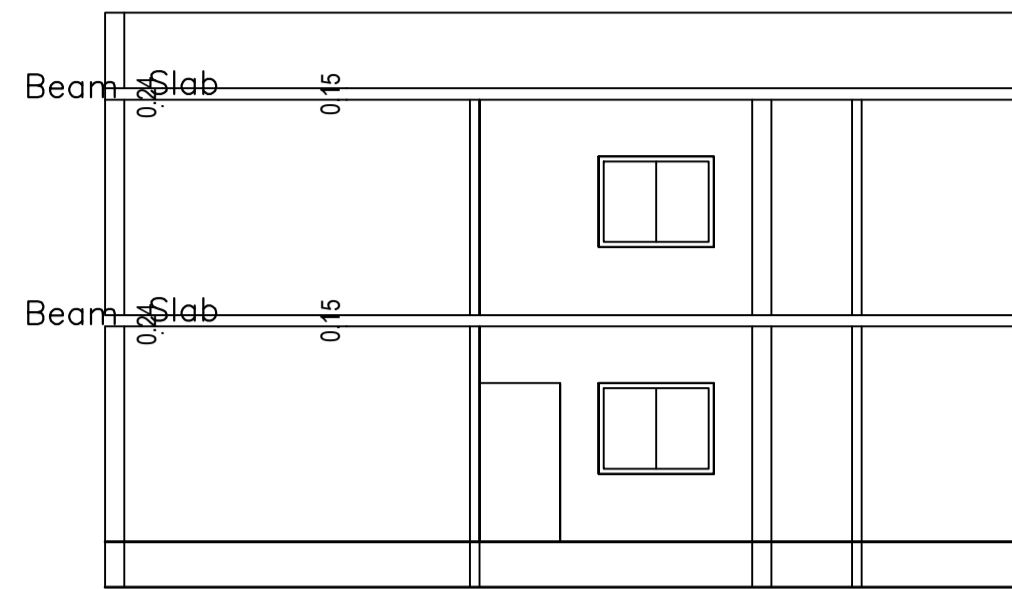

SECTION ON X-X

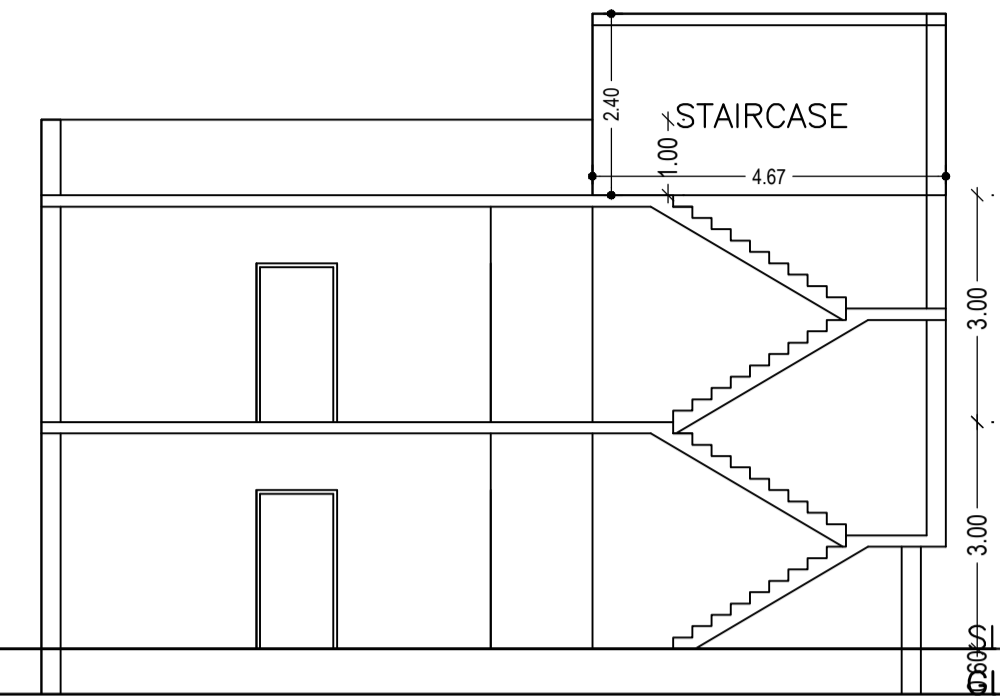

SECTION ON Y-Y

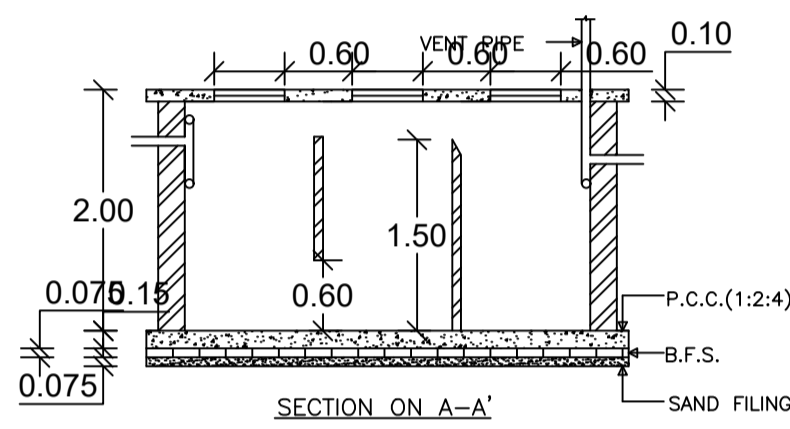

SECTION ON A-A

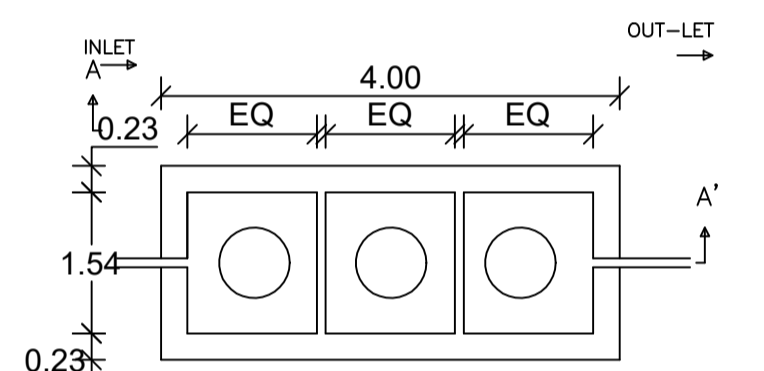

PLAN

DETAILS OF SEPTIC TANK

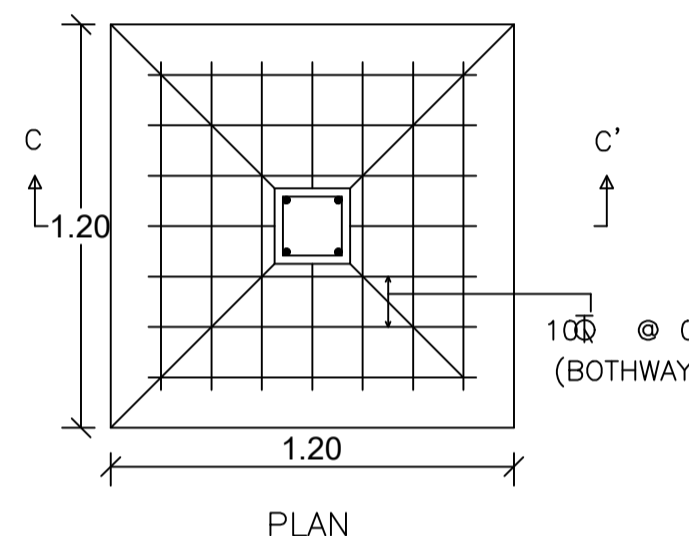

PLAN

DETAILS OF FOUNDATION

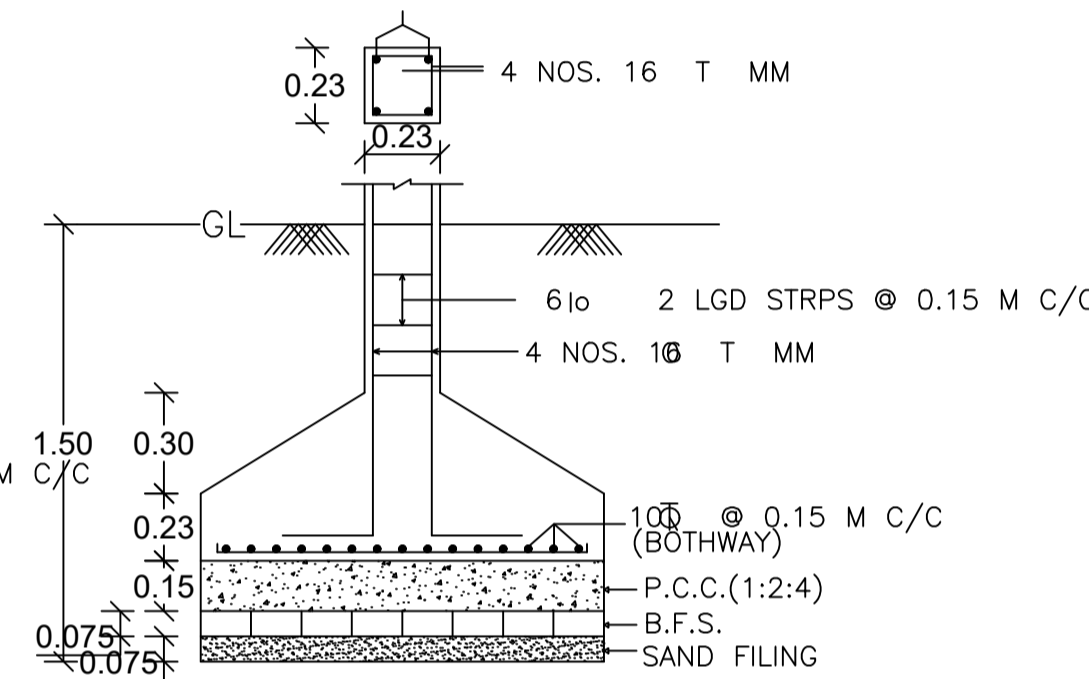

SECTION ON C-C

DETAILS OF FOUNDATION

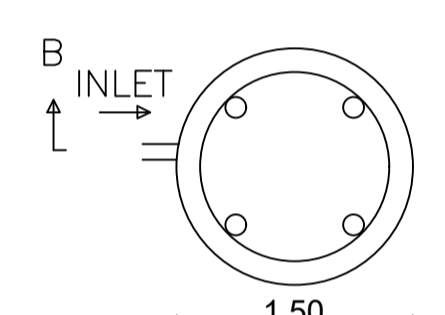
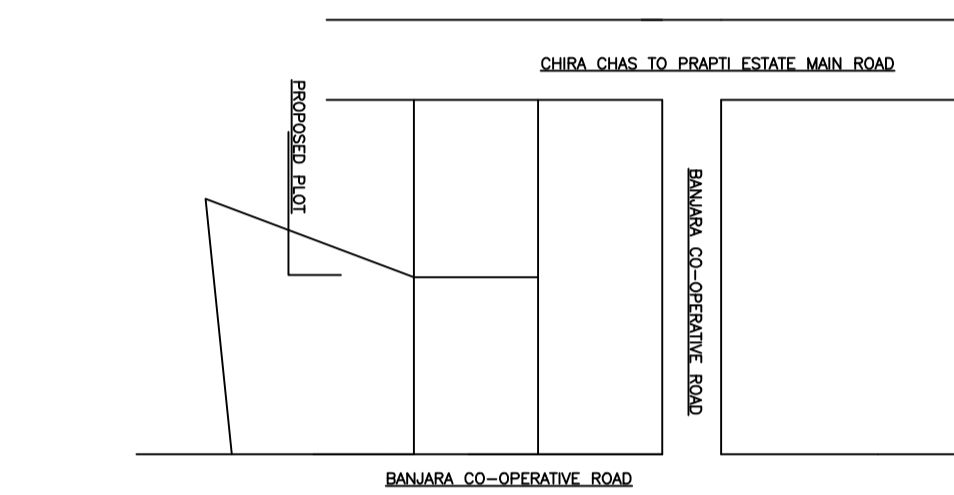

PLAN

DETAILS OF WATER HARVESTING

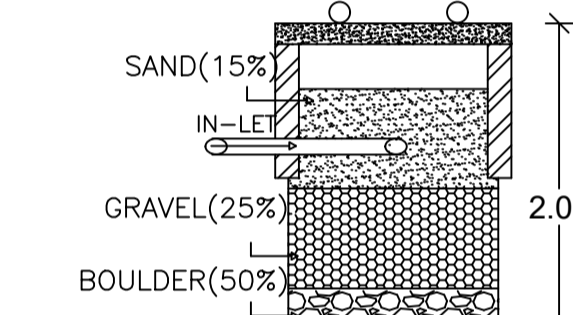

SECTION ON B-B

DETAILS OF WATER HARVESTING

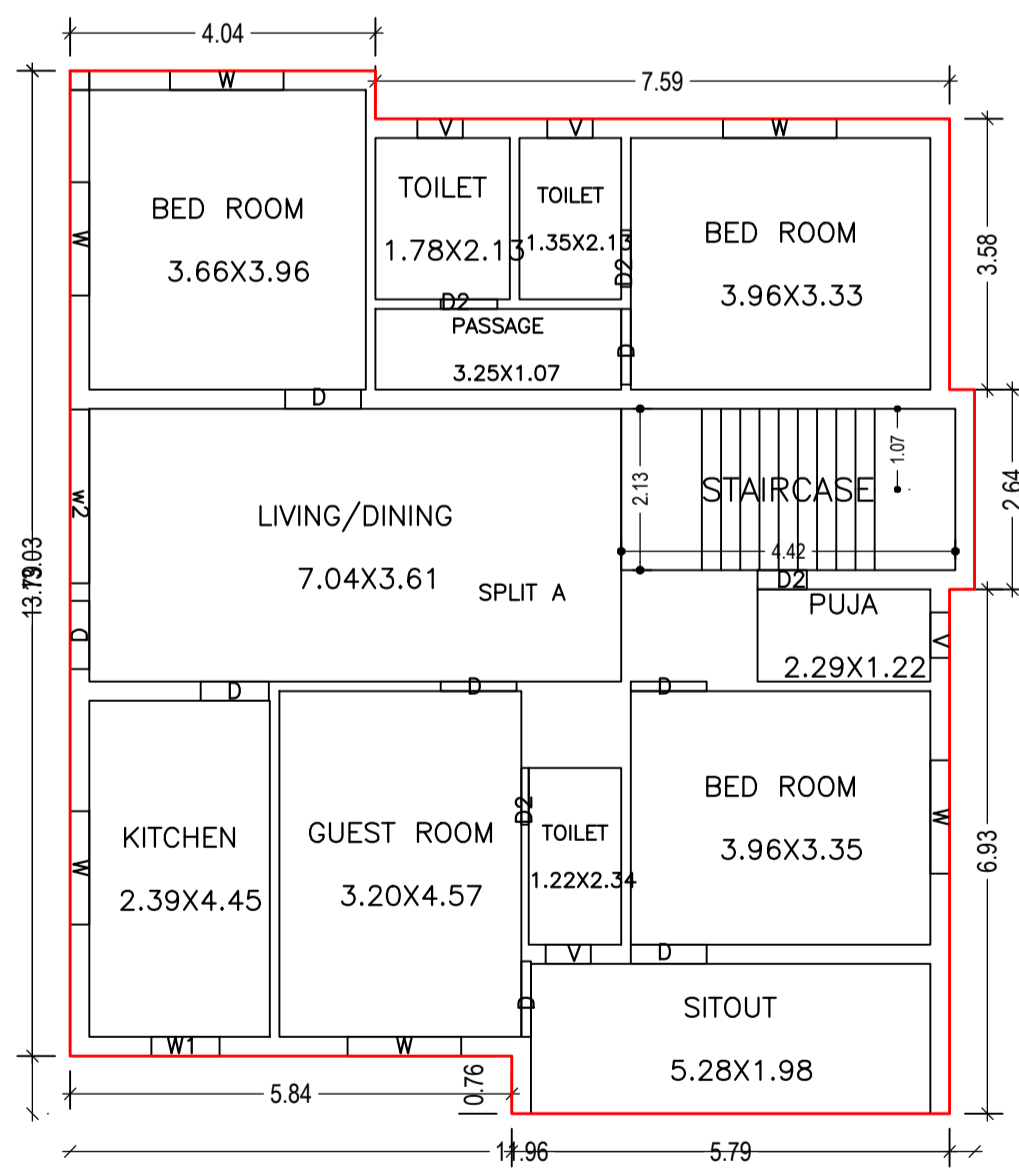
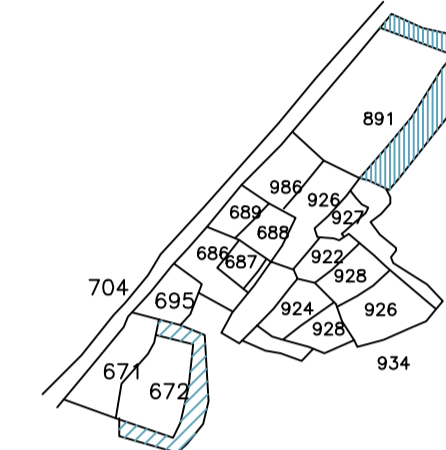

GROUND FLOOR PLAN (Proposed) (SCALE 1:100)

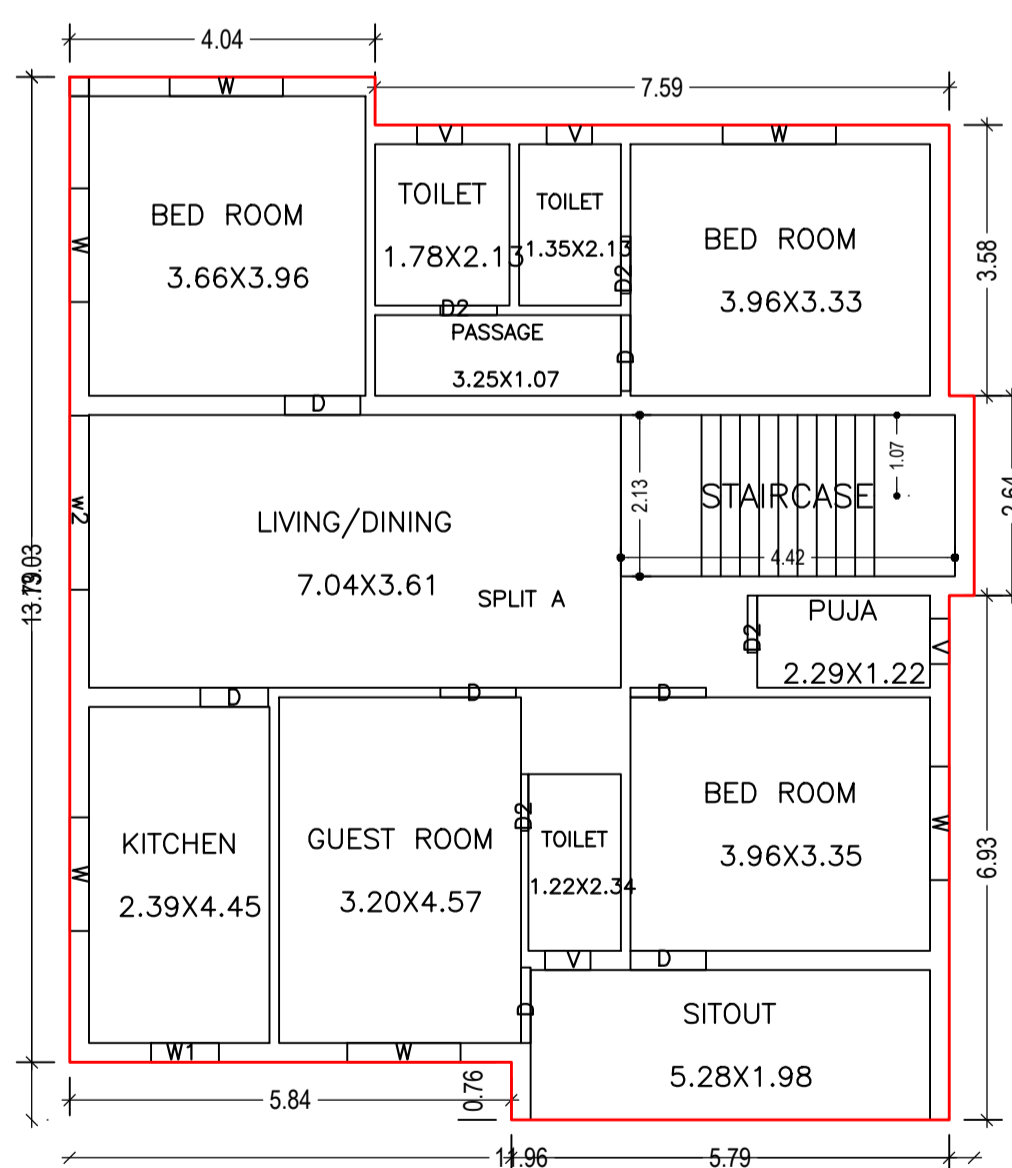

FIRST FLOOR PLAN (Proposed) (SCALE 1:100)

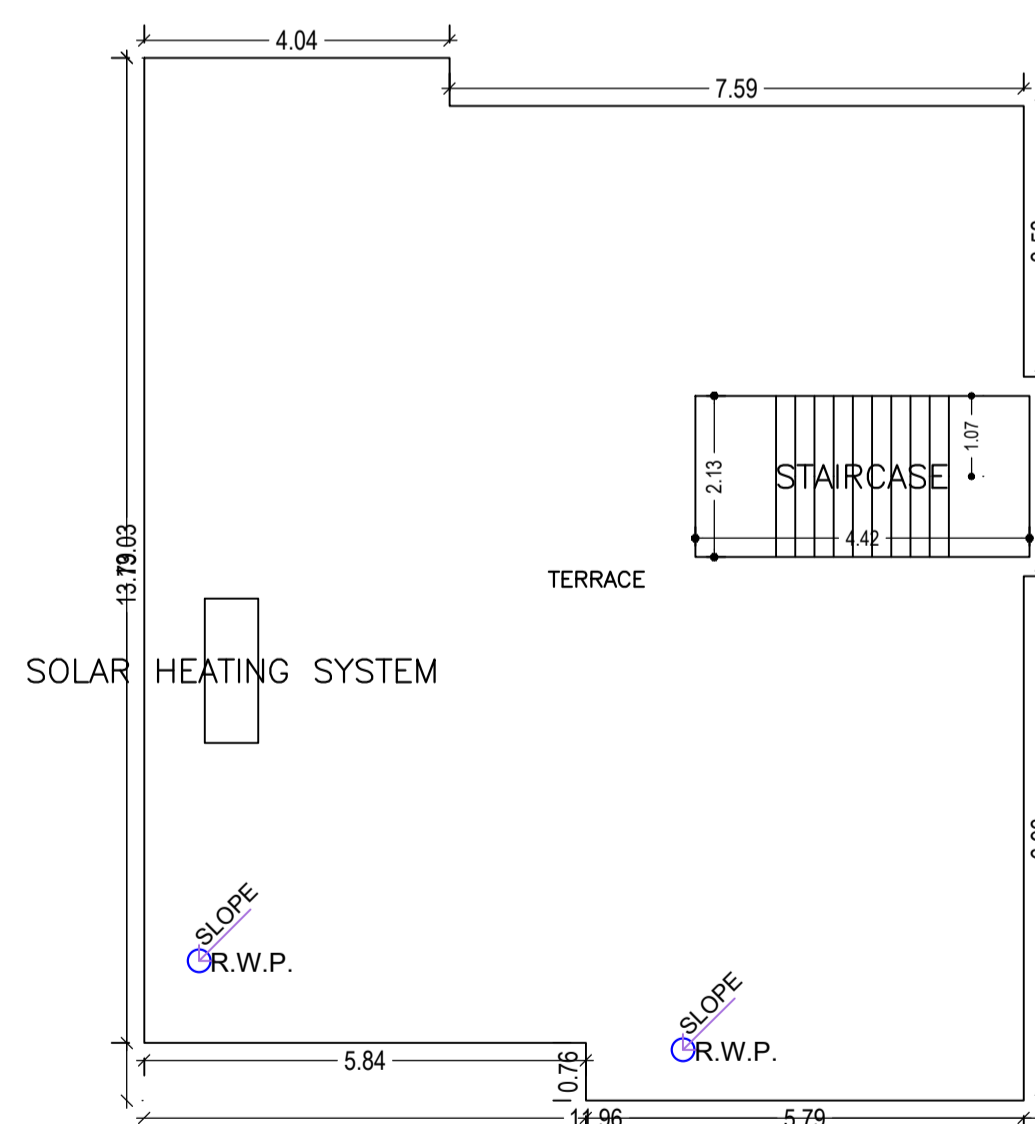

TERRACE FLOOR PLAN (SCALE 1:100)

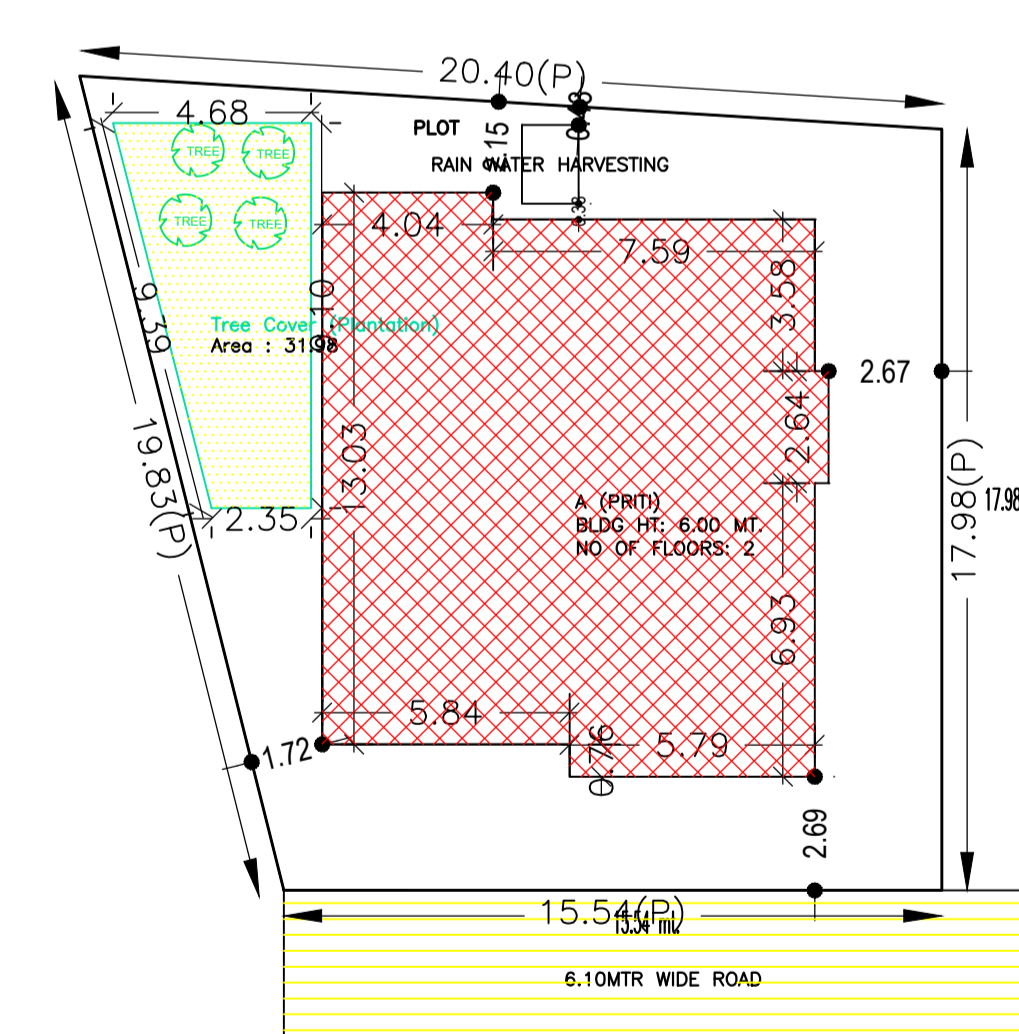

SITE PLAN

AREA STATEMENT CHAS MUNICIPAL CORPORATION	VERSION NO.: 1.0.66
PROJECT DETAIL:	VERSION DATE: 16/10/2020
Region: JHARKHAND URBAN LOCAL BODIES	Plot Use: Residential
District: BOKARO	Plot SubUse: Bungalow/ Dwelling / Non Apartment
Authority: CHAS MUNICIPAL CORPORATION	PlotNearbyReligiousStructure: NA
Inward No: CMC/BP/0057/W02/2023	Plot/SubPlot No: 684,686
Application Type: General Proposal	North: Plot No. - CO-OPERATIVE PLOT NO. - G-03
Project Type: Building Permission	South: Plot No. - CO-OPERATIVE PLOT NO. - G-1
Nature of Development: New	East: Road Width - ROAD
Location of Development Area: Old Area	West: Plot No. - SURVEY PLOT NO. - 685
AREA DETAILS:	SQ.MT.
AREA OF PLOT (Minimum)	(A) 332.50
NET AREA OF PLOT(Gross Plot Area - Deduction from Gross Plot area)	(A-Deductions) 332.50
Deduction for Balance Plot Area(from Gross Plot Area)	
Common Plot	31.98
Total	31.98
BALANCE AREA OF PLOT(Net Plot Area - Recreational/Amenity spaces)	(A-Deductions) 300.52
PLOT AREA FOR COVERAGE(Net Plot Area)	(A-Deductions) 332.50
Plot Area for FAR (Net Plot Area + RoadWidening Area)	(A-Deductions) 332.50
COVERAGE CHECK	
Permissible Coverage area ( 60.00 % )	199.50
Proposed Coverage Area ( 45.73 % )	152.05
Total Prop. Coverage Area ( 45.73 % )	152.05
Balance coverage area ( 14.27 % )	47.45
FAR CHECK	
Perm. FAR Area ( 2.500 )	831.25
Total Perm. FAR area	831.25
Residential FAR	304.09
Proposed FAR Area	304.09
Total Proposed FAR Area	304.09
Consumed FAR (Factor)	0.91
Balance FAR Area	527.16
BUILT UP AREA CHECK	
Total Proposed BuiltUp Area	304.10
ARCHITECT (Regd)	AMRIT KUMAR MAHATO
ENGINEER (Regd)	
SUPERVISOR (Regd)	PRITI KUMARI DEVI
OWNER (Regd)	
DEVELOPMENT AUTHORITY	LOCAL BODY

SCHEDULE OF DOOR:

BUILDING NAME	NAME	LENGTH	HEIGHT	NOS
A (PRITI)	D2	0.65	2.10	01
A (PRITI)	D2	0.75	2.10	07
A (PRITI)	D	0.90	2.10	03
A (PRITI)	D	1.00	2.10	12

SCHEDULE OF WINDOW/VENTILATION:

BUILDING NAME	NAME	LENGTH	HEIGHT	NOS
A (PRITI)	V	0.60	1.20	08
A (PRITI)	W1	0.90	1.20	02
A (PRITI)	W	1.50	1.20	12
A (PRITI)	W2	2.30	1.20	02

Building :A (PRITI)

Floor Name	Total Built Up Area (Sq.mt.)	Proposed FAR Area (Sq.mt.) Resi.	Total FAR Area (Sq.mt.)	Total Consumed Additional FAR Area (Sq.mt.)	Tnmt (No.)
Ground Floor	152.05	152.05	152.05	152.05	01
First Floor	152.05	152.05	152.05	152.05	00
Terrace Floor	0.00	0.00	0.00	0.00	00
Total :	304.10	304.10	304.10	304.10	01
Total Number of Same Buildings :	1				
Total :	304.10	304.10	304.10	304.10	01

Buildingwise Floor FAR Details

Floor Name	Building Name		Total	
	Proposed Built Up Area (Sq.mt.)	Proposed FAR Area (Sq.mt.)	Total Proposed Built Up Area (Sq.mt.)	Total FAR Area (Sq.mt.)
Ground Floor	152.05	152.05	152.05	152.05
First Floor	152.05	152.05	152.05	152.05
Terrace Floor	0.00	0.00	0.00	0.00
Total :	304.10	304.10	304.10	304.10

UnitBUA Table for Building :A (PRITI)

FLOOR	Name	UnitBUA Type	UnitBUA Area	Carpet Area	No. of Rooms	No. of Tenement
GROUND FLOOR PLAN	SPLIT A	FLAT	304.09	303.96	12	1
FIRST FLOOR PLAN	SPLIT A	FLAT	0.00	0.00	12	0
Total:	-	-	304.09	303.96	24	1

FAR & Tenement Details (Table 4c-1) (Proposed) (SCALE 1:100)

Building	No. of Same Bldg	Total Built Up Area (Sq.mt.)	Proposed FAR Area (Sq.mt.) Resi.	Total FAR Area (Sq.mt.)	Total Consumed Additional FAR Area (Sq.mt.)	Tnmt (No.)
A (PRITI)	1	304.10	304.10	304.10	304.10	01
Grand Total :	1	304.10	304.10	304.10	304.10	01

Building USE/SUBUSE Details

Building Name	Building Use	Building SubUse	Building Structure
A (PRITI)	Residential	Bungalow/ Dwelling / Non Apartment	Non-Highrise

COLOR INDEX

PLOT BOUNDARY	Black
ABUTTING ROAD	Red
PROPOSED CONSTRUCTION COMMON PLOT	Green
ROAD WIDENING AREA	Yellow
EXISTING (To be retained)	Blue
EXISTING (To be demolished)	Orange

LTP NAME AND SIGNATURE	STRUCTURAL ENG'S NAME AND SIGNATURE	BUILDER NAME AND SIGNATURE	DIGITAL SIGNATURE
AMRIT KUMAR MAHATO CMC/DFTM/0004/2019			