

Proposal Basic Information

Proposal File No.	CMP/0228/W05/2023
Owner Name	SHYAM LAL RAM
Khata No	102
Plot No	1217, 118
Village Name	Jamgora
Use	Residential
SubUse	Bungalow/ Dwelling / Non Apartment

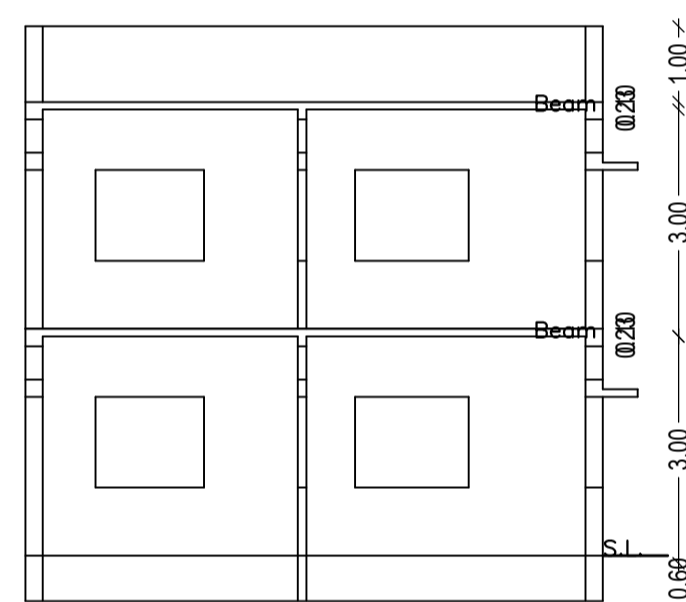
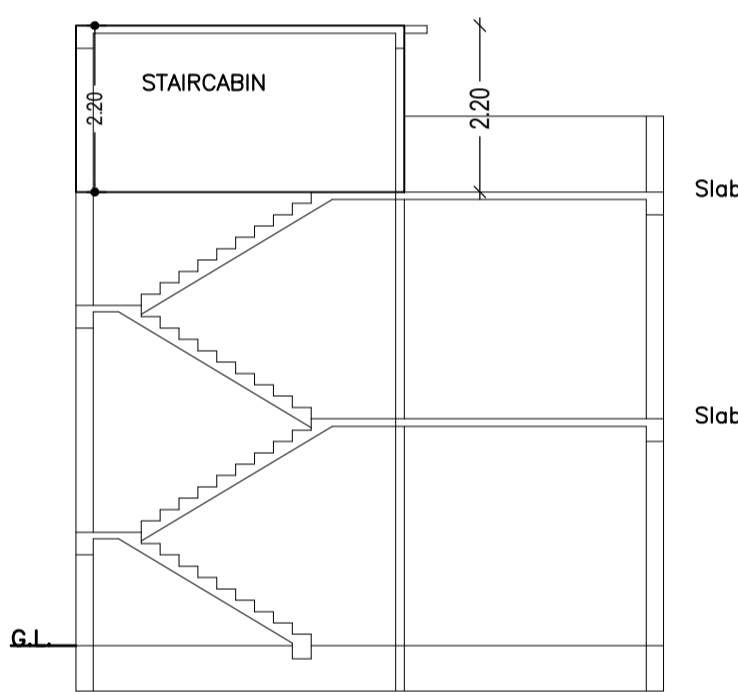
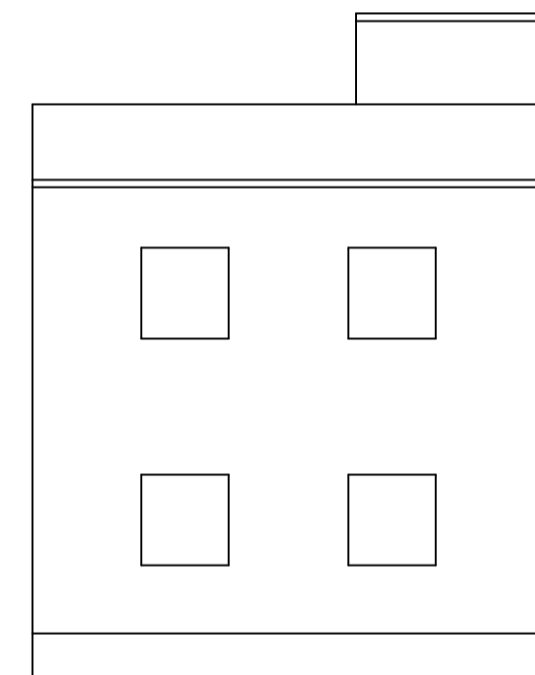
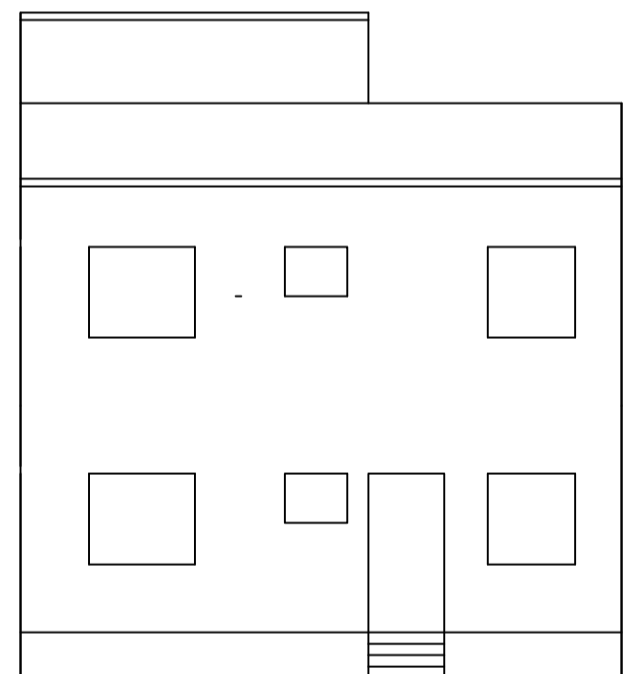
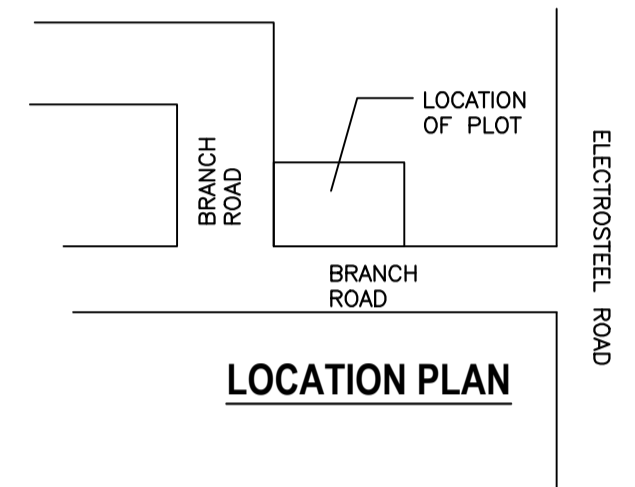
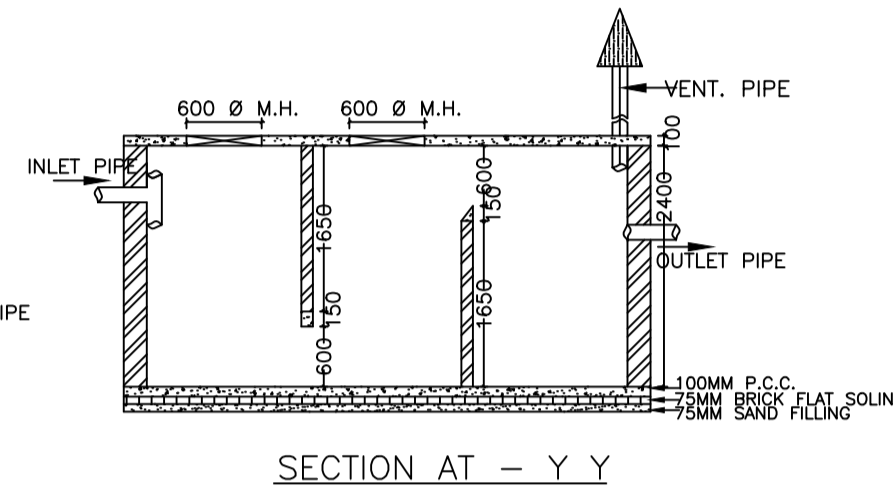
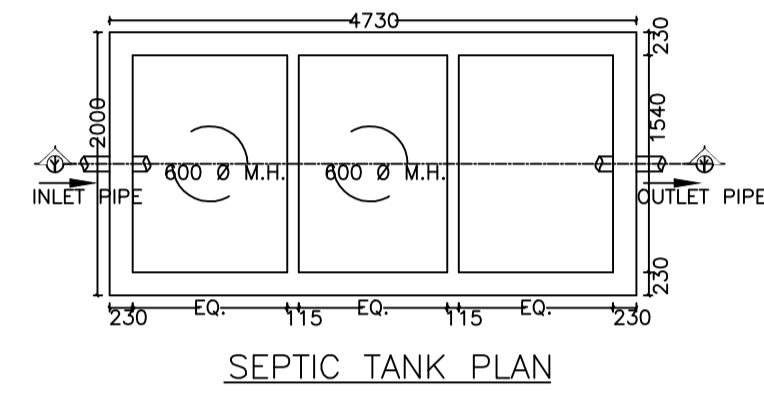
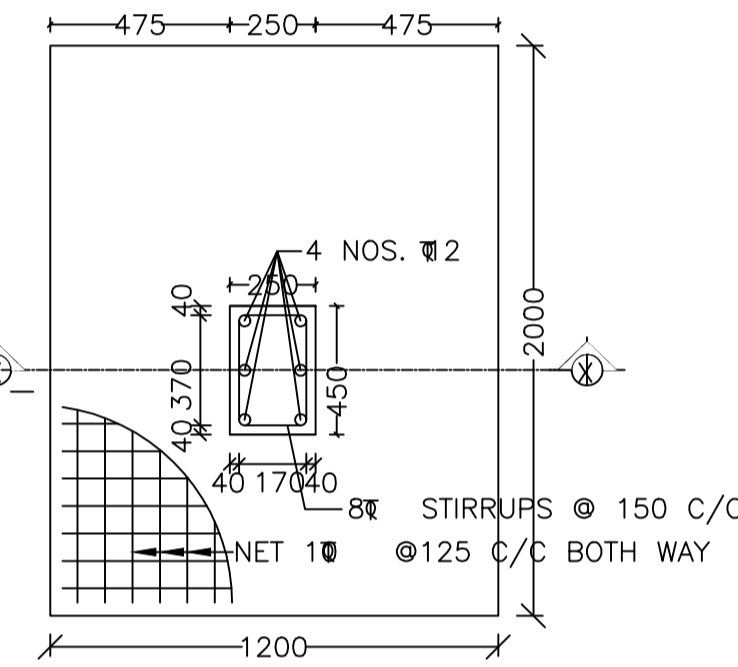
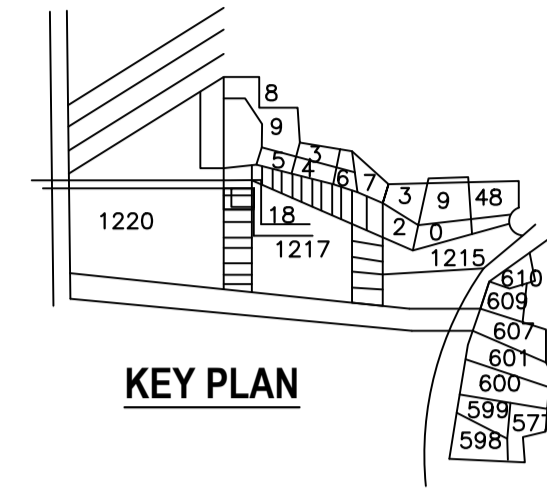
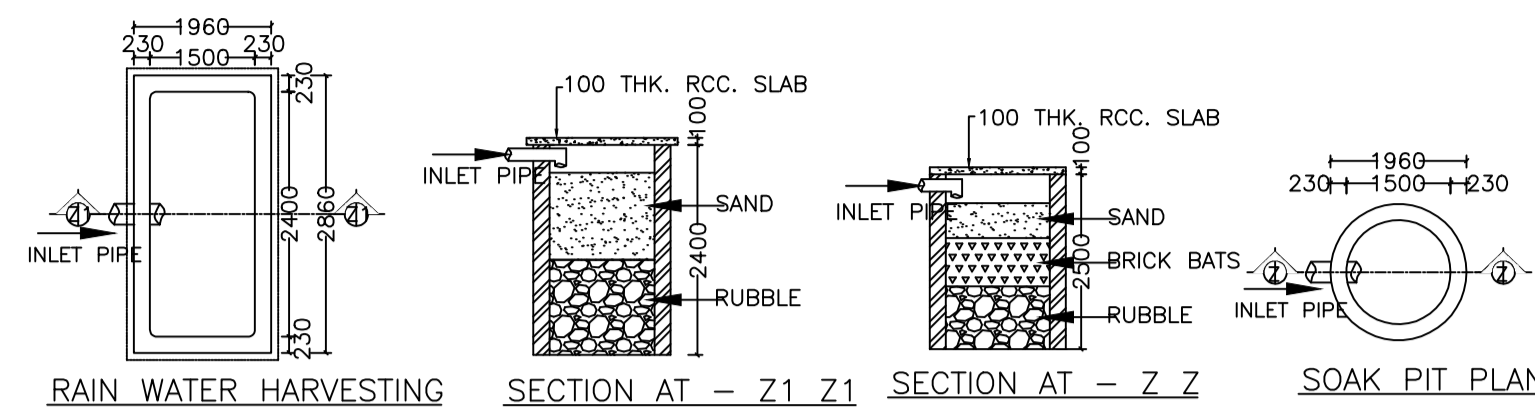
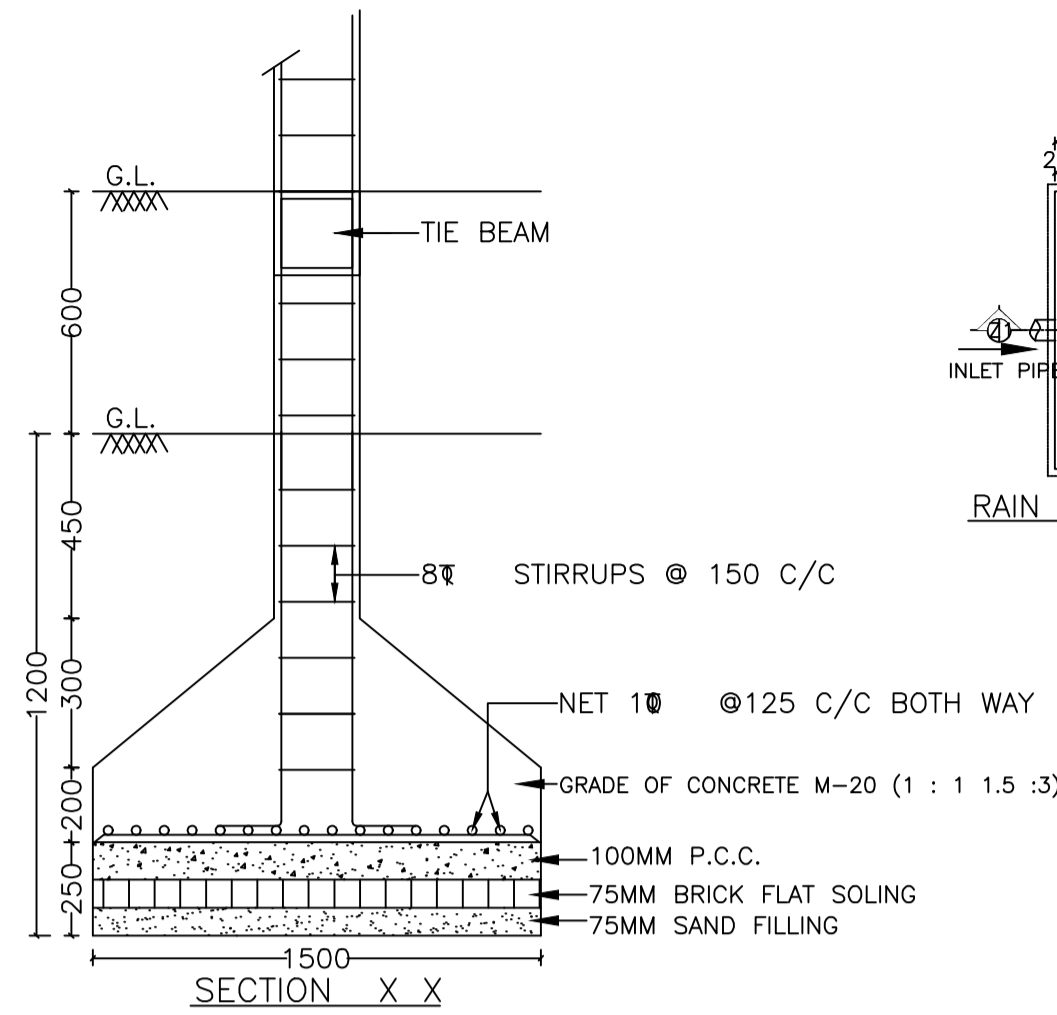

AREA STATEMENT CHAS MUNICIPAL CORPORATION	VERSION NO. : 1.0.66	
	VERSION DATE: 16/10/2020	
PROJECT DETAIL:		
Region : JHARKHAND URBAN LOCAL BODIES	Plot Use: Residential	
District: BOKARO	Plot SubUse: Bungalow/ Dwelling / Non Apartment	
Authority: CHAS MUNICIPAL CORPORATION	PlotNearby/Religious/Structure: NA	
Inward No: CMC/EP/0028/W05/2023	Plot/SubPlot No: 1217,1218	
Application Type: General Proposal	North: Road Width - 6	
Project Type: Building Permission	South: Plot No. - 11	
Nature of Development: New	East: Road Width - 6	
Location of Development Area: Old Area	West: Plot No. - 6	
AREA DETAILS:		
AREA OF PLOT (Minimum)	(A)	SQ.MT.
NET AREA OF PLOT(Gross Plot Area - Deduction from Gross Plot area)	(A-Deductions)	91.20
Deduction for Balance Plot Area(from Gross Plot Area)		
Common Plot		14.06
Total		14.06
BALANCE AREA OF PLOT(Net Plot Area - Recreational/Amenity space)	(A-Deductions)	77.14
PLOT AREA FOR COVERAGE(Net Plot Area)	(A-Deductions)	91.20
Plot Area for FAR (Net Plot Area + RoadWidening Area)	(A-Deductions)	91.20
COVERAGE CHECK		
Permissible Coverage area (70.00 %)		63.84
Proposed Coverage Area (60.45 %)		55.13
Total Prop. Coverage Area (60.45 %)		55.13
Balance coverage area (9.55 %)		8.71
FAR CHECK		
Perm. FAR Area (1.800)		164.16
Total Perm. FAR area		164.16
Residential FAR		110.27
Proposed FAR Area		110.27
Total Proposed FAR Area		110.27
Consumed FAR (Factor)		1.21
Balance FAR Area		53.89
BUILT UP AREA CHECK		
Total Proposed BuiltUp Area		110.26
ARCHITECT (Regd)	MANOJ KUMAR	
ENGINEER (Regd)		
SUPERVISOR (Regd)		
OWNER (Regd)	SHYAM LAL RAM	
DEVELOPMENT AUTHORITY		LOCAL BODY

Building :A (SHYAM LAL RAM)

Floor Name	Total Built Up Area (Sq.mt.)	Proposed FAR Area (Sq.mt.) Resi.	Total FAR Area (Sq.mt.)	Total Consumed Additional FAR Area (Sq.mt.)	Tnmt (No.)
Ground Floor	55.13	55.13	55.13	55.13	01
First Floor	55.13	55.13	55.13	55.13	00
Terrace Floor	0.00	0.00	0.00	0.00	00
Total :	110.26	110.26	110.26	110.26	01
Total Number of Same Buildings	1				
Total :	110.26	110.26	110.26	110.26	01

SCHEDULE OF DOOR:

BUILDING NAME	NAME	LENGTH	HEIGHT	NOS
A (SHYAM LAL RAM)	D2	0.75	2.10	02
A (SHYAM LAL RAM)	D1	0.90	2.10	02
A (SHYAM LAL RAM)	D	1.00	2.10	06

SCHEDULE OF WINDOW/VENTILATION:

BUILDING NAME	NAME	LENGTH	HEIGHT	NOS
A (SHYAM LAL RAM)	V	0.60	1.20	02
A (SHYAM LAL RAM)	W	1.50	1.20	14

Buildingwise Floor FAR Details

Floor Name	Building Name A (SHYAM LAL RAM)		Total	
	Proposed Built Up Area (Sq.mt.)	Proposed FAR Area (Sq.mt.)	Total Proposed Built Up Area (Sq.mt.)	Total FAR Area (Sq.mt.)
Ground Floor	55.13	55.13	55.13	55.13
First Floor	55.13	55.13	55.13	55.13
Terrace Floor	0.00	0.00	0.00	0.00
Total :	110.26	110.26	110.26	110.26

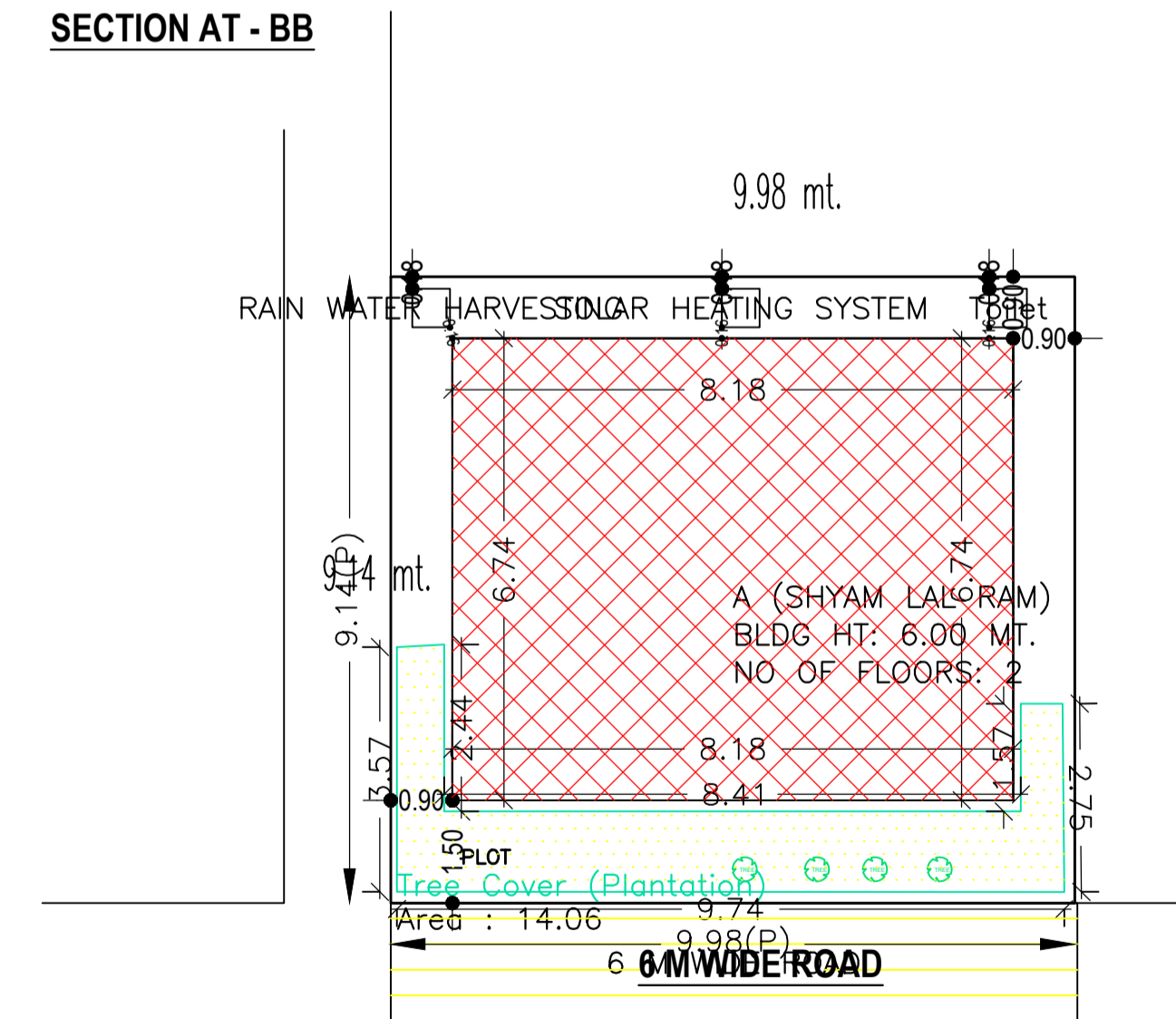
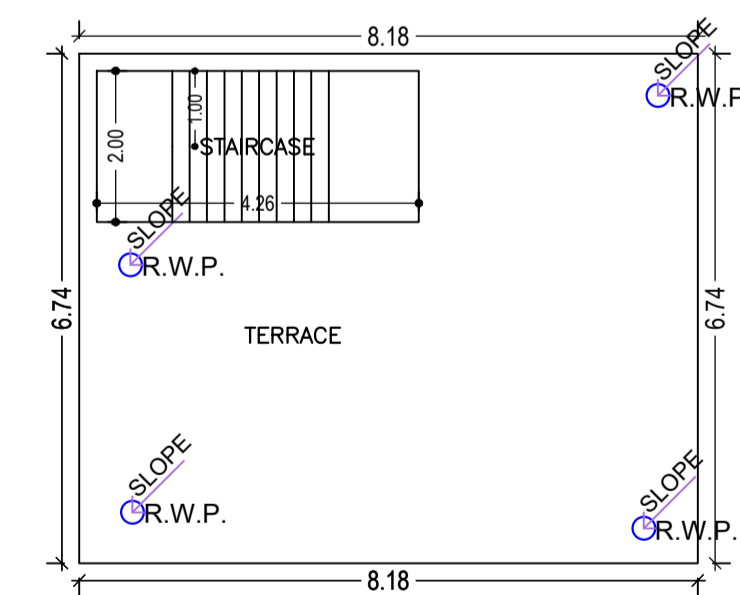
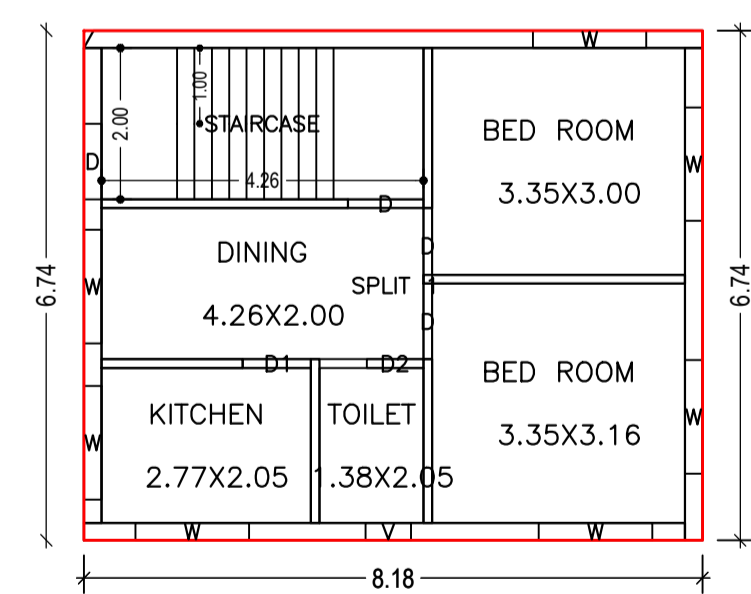
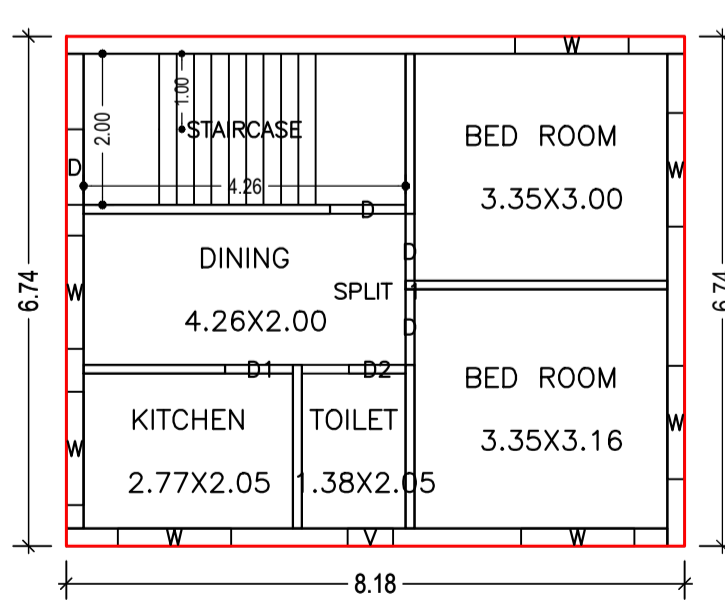

FAR & Tenement Details (Table 4c-1)

Building	No. of Same Bldg	Total Built Up Area (Sq.mt.)	Proposed FAR Area (Sq.mt.) Resi.	Total FAR Area (Sq.mt.)	Total Consumed Additional FAR Area (Sq.mt.)	Tnmt (No.)
A (SHYAM LAL RAM)	1	110.26	110.26	110.26	110.26	01
Grand Total :	1	110.26	110.26	110.26	110.26	01

COLOR INDEX

PLOT BOUNDARY	Black
ABUTTING ROAD	Red
PROPOSED CONSTRUCTION	Green
COMMON PLOT	Yellow
ROAD WIDENING AREA	Blue
EXISTING (To be retained)	Light Blue
EXISTING (To be demolished)	White

UnitBUA Table for Building :A (SHYAM LAL RAM)

FLOOR	Name	UnitBUA Type	UnitBUA Area	Carpet Area	No. of Rooms	No. of Tenement
GROUND FLOOR PLAN	SPLIT 1	FLAT	78.46	76.24	5	1
FIRST FLOOR PLAN	SPLIT 1	FLAT	0.00	0.00	5	0
Total:	-	-	78.46	76.24	10	1

LTP NAME AND SIGNATURE	STRUCTURAL ENG'S NAME AND SIGNATURE	BUILDER NAME AND SIGNATURE	DIGITAL SIGNATURE
MANOJ KUMAR CMC/SUP/0016/2018			