

Proposal Basic Information	
Proposal File No.	CMC/BP/0187/W02/2023
Owner Name	RAJIV KUMAR UPADHYAY
Khata No	01
Plot No	1274
Village Name	Chas
Use	Residential
SubUse	Bungalow/ Dwelling / Non Apartment

AREA STATEMENT CHAS MUNICIPAL CORPORATION		VERSION NO. : 1.0.66
PROJECT DETAIL:		VERSION DATE: 16/10/2020
Region: JHARKHAND URBAN LOCAL BODIES	Plot Use: Residential	
District: BOKARO	Plot SubUse: Bungalow/ Dwelling / Non Apartment	
Authority: CHAS MUNICIPAL CORPORATION	PlotNearbyReligiousStructure: NA	
Inward No: CMC/BP/0187/W02/2023	PlotSubPlot No: 1274	
Application Type: General Proposal	North: Plot No. - PART OF PLOT	
Project Type: Building Permission	South: CTS No. - KISHORI SHARMA	
Nature of Development: New	East: CTS No. - GITA SINGH & NARENDRA KUMAR SINGH	
Location of Development Area: Old Area	West: Road Width - ROAD	
AREA DETAILS:		SQ.MT.
AREA OF PLOT (Minimum)	(A)	222.96
NET AREA OF PLOT(Gross Plot Area - Deduction from Gross Plot area)	(A-Deductions)	222.96
Deduction for Balance Plot Area(from Gross Plot Area)		
Common Plot		19.02
Total		19.02
BALANCE AREA OF PLOT(Net Plot Area - Recreational/Amenity space)	(A-Deductions)	203.94
PLOT AREA FOR COVERAGE(Net Plot Area)	(A-Deductions)	222.96
Plot Area for FAR (Net Plot Area + Road Widening Area)	(A-Deductions)	222.96
COVERAGE CHECK		
Permissible Coverage area (70.00 %)		156.07
Proposed Coverage Area (46.45 %)		103.56
Total Prop. Coverage Area (46.45 %)		103.56
Balance coverage area (23.55 %)		52.51
FAR CHECK		
Perm. FAR Area (2.500)		557.40
Total Perm. FAR Area		557.40
Residential FAR		209.49
Proposed FAR Area		209.49
Total Proposed FAR Area		209.49
Consumed FAR (Factor)		0.94
Balance FAR Area		347.91
BUILT UP AREA CHECK		
Total Proposed BuiltUp Area		211.86
ARCHITECT (Regd)		AMRIT KUMAR MAHATO
ENGINEER (Regd)		
SUPERVISOR (Regd)		RAJIV KUMAR UPADHYAY
OWNER (Regd)		
DEVELOPMENT AUTHORITY		LOCAL BODY

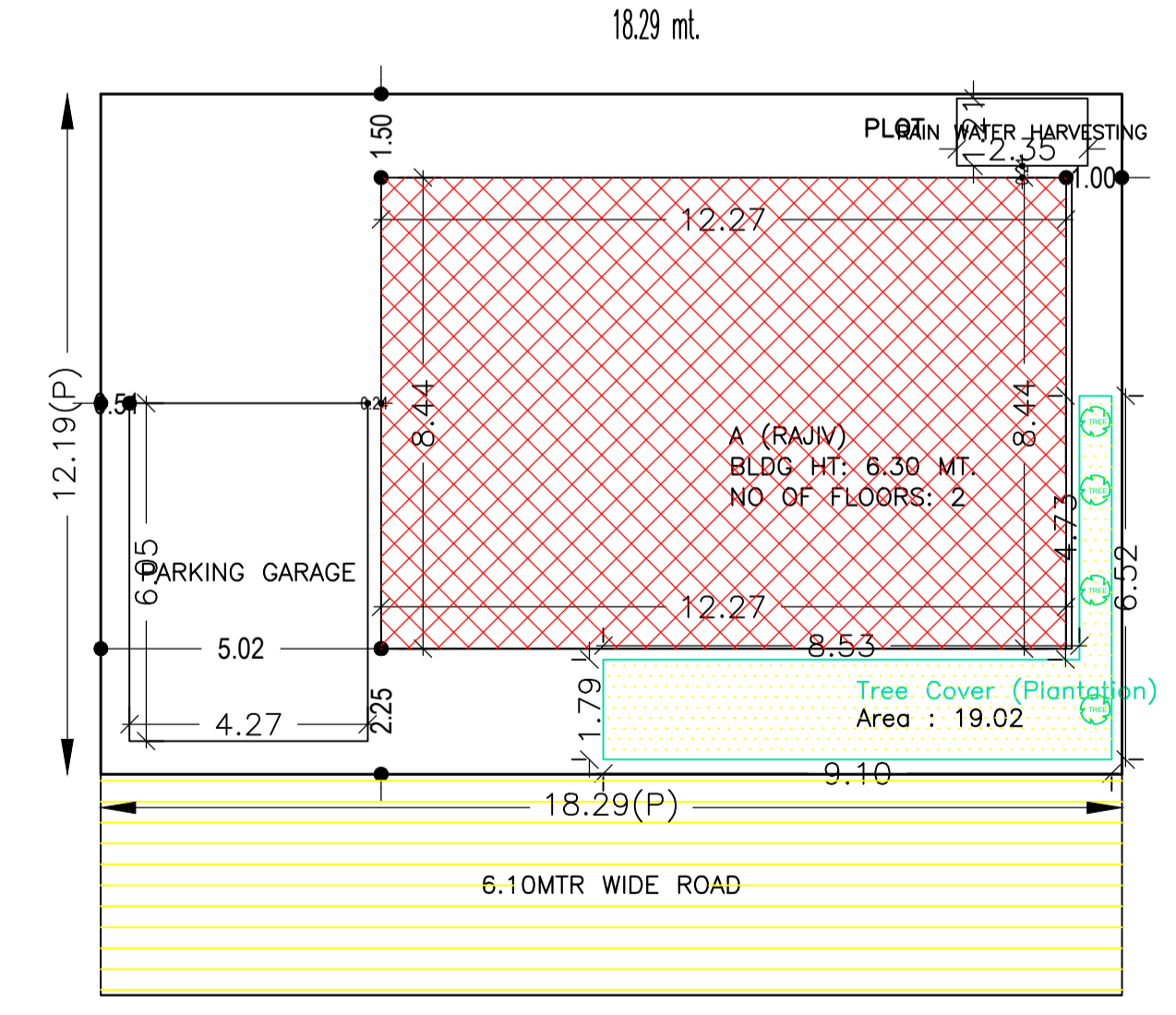
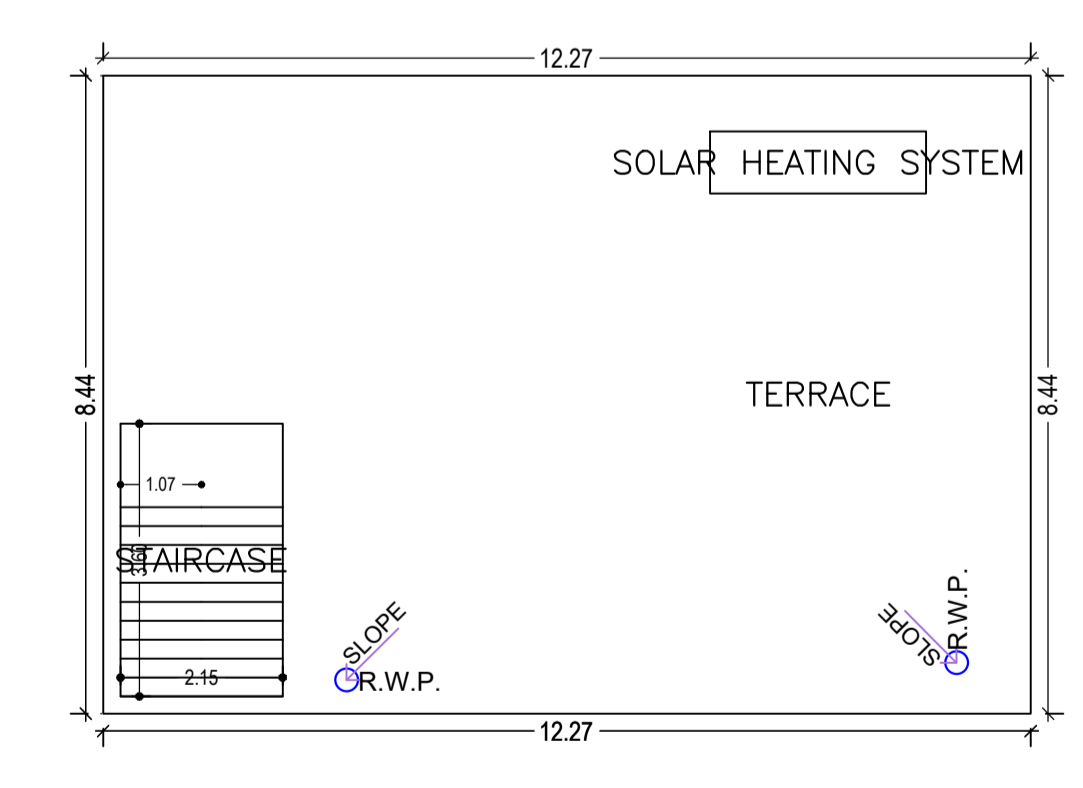
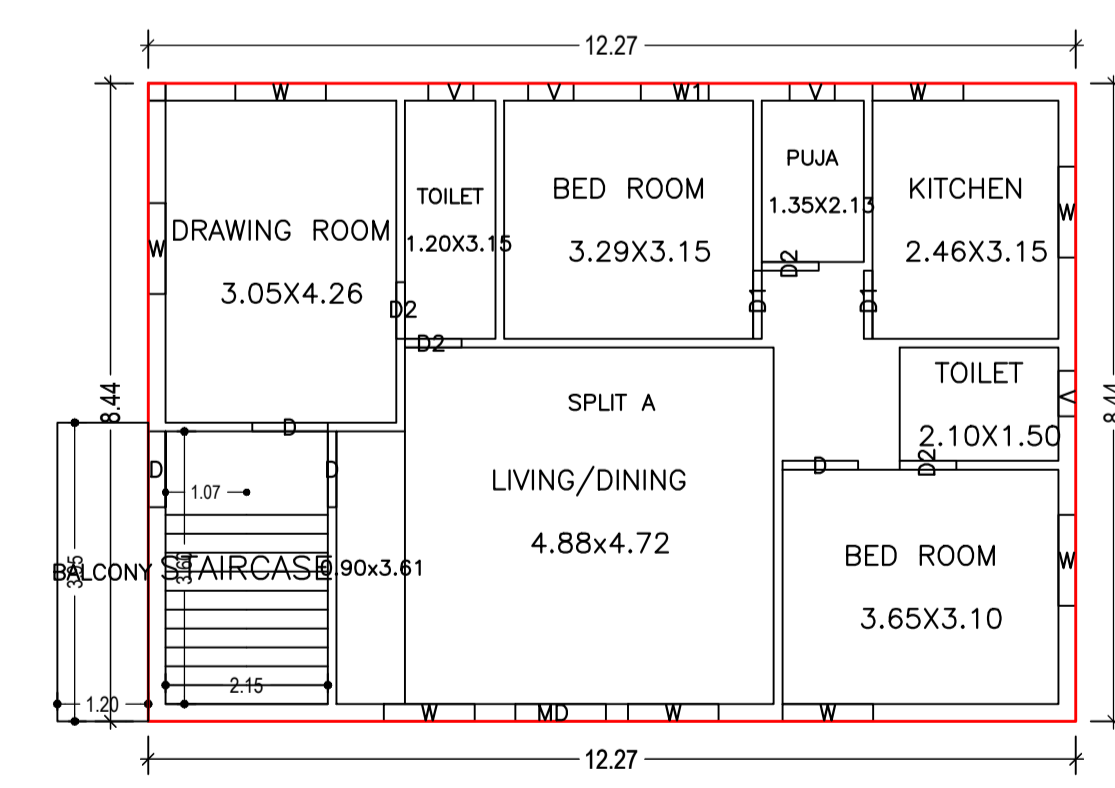
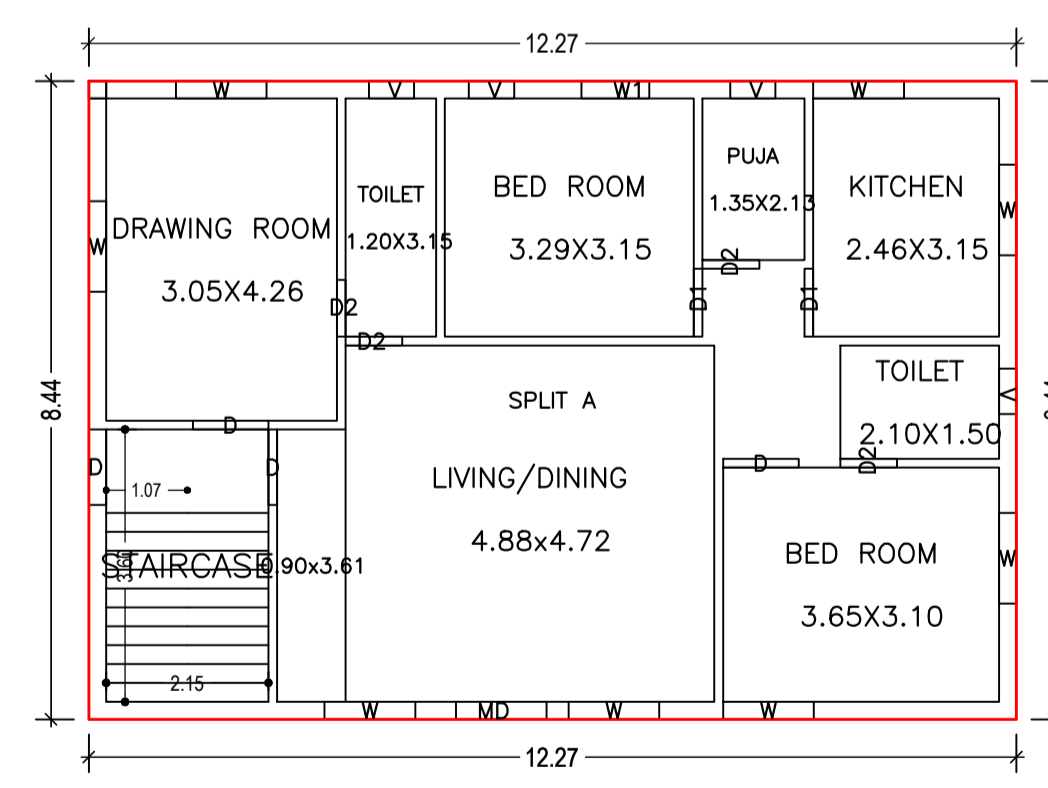
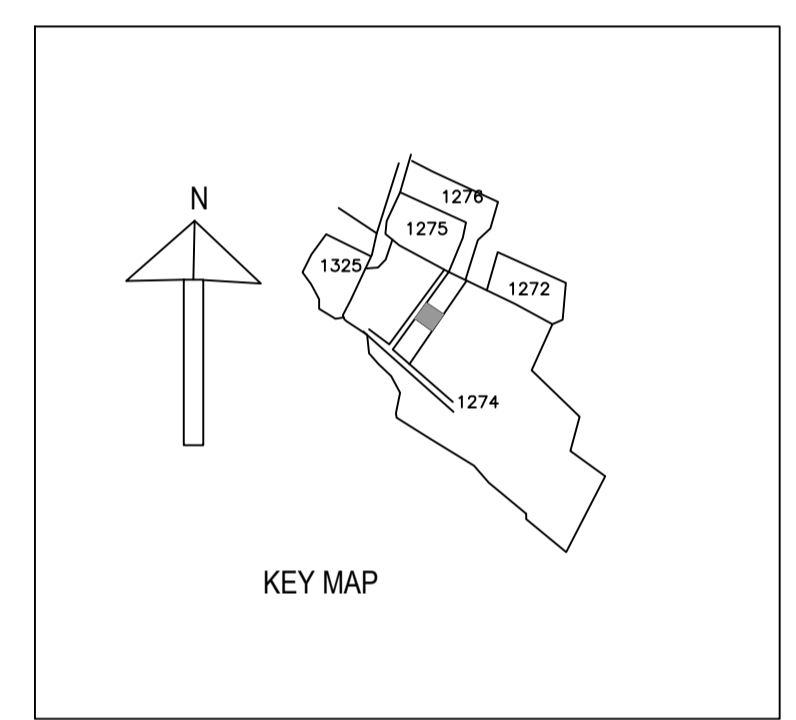
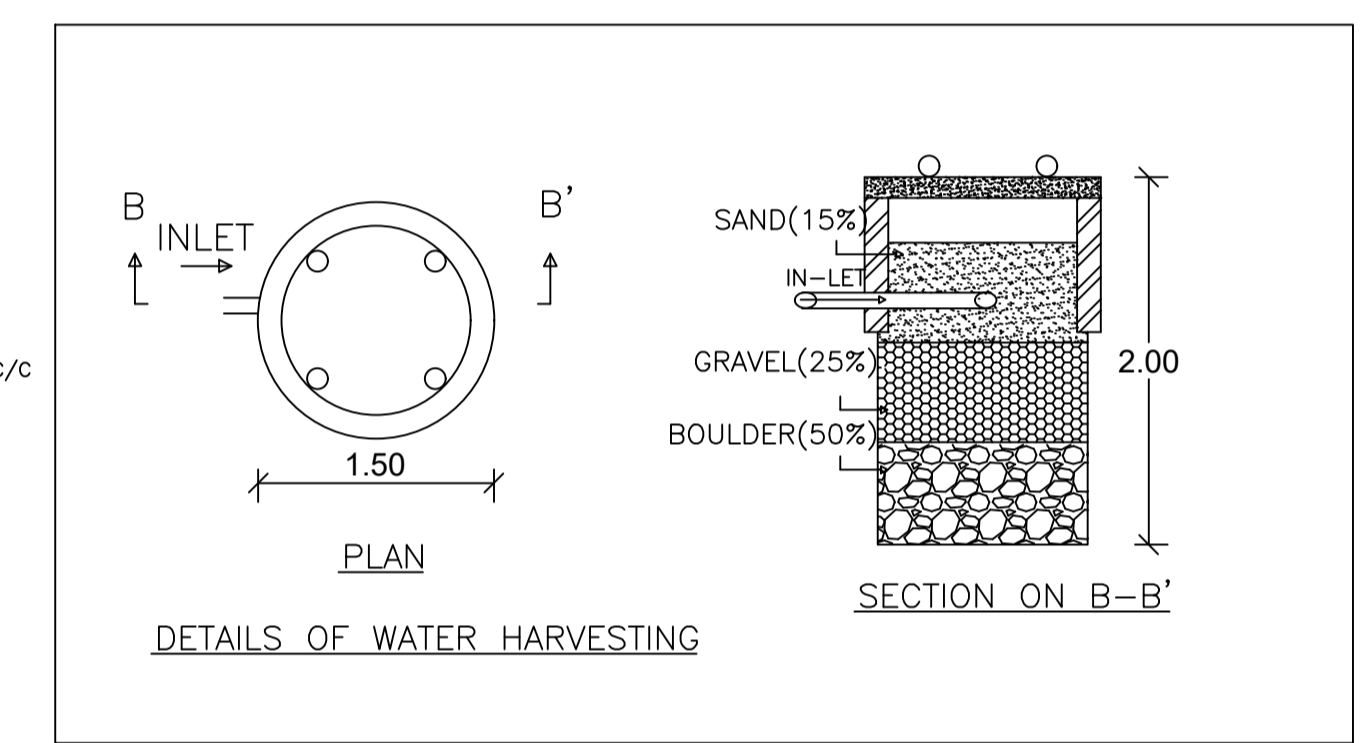
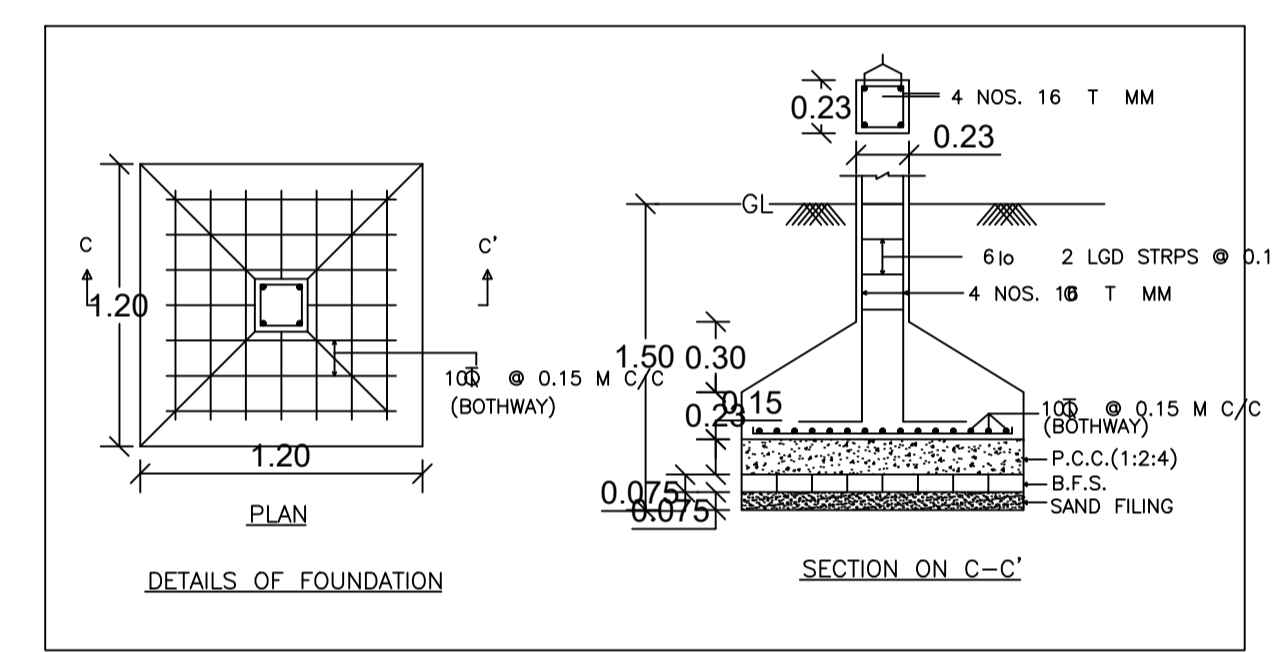
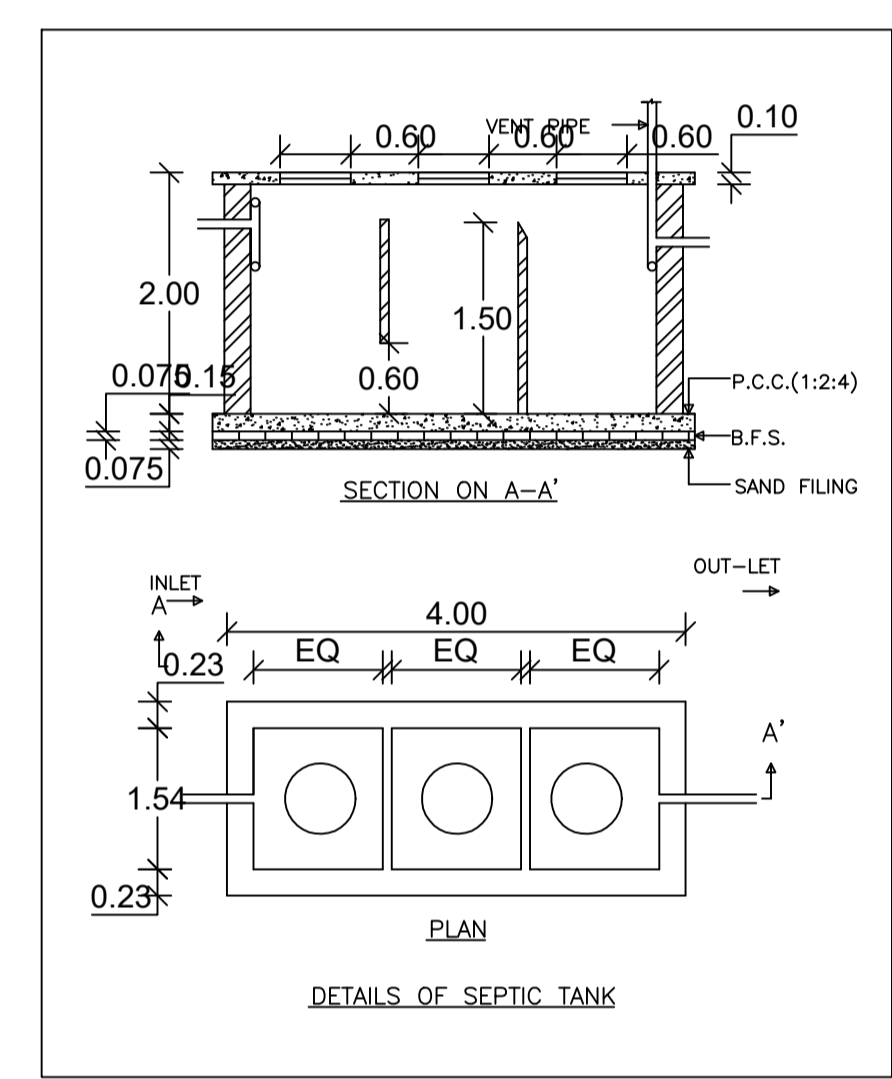

Building :A (RAJIV)						
Floor Name	Total Built Up Area (Sq.mt.)	Deductions (Area in Sq.mt.)	Proposed FAR Area (Sq.mt.)	Total FAR Area (Sq.mt.)	Total Consumed Additional FAR Area (Sq.mt.)	Tnmt (No.)
Ground Floor	103.56	0.00	103.56	103.56	103.56	01
First Floor	108.30	2.37	105.93	105.93	105.93	01
Terrace Floor	0.00	0.00	0.00	0.00	0.00	00
Total	211.86	2.37	209.49	209.49	209.49	01

SCHEDULE OF DOOR:					
BUILDING NAME	NAME	LENGTH	HEIGHT	NOS	
A (RAJIV)	D2	0.75	2.10	08	
A (RAJIV)	D1	0.90	2.10	04	
A (RAJIV)	D	1.00	2.10	06	
A (RAJIV)	MD	1.20	2.10	02	

SCHEDULE OF WINDOW/VENTILATION:					
BUILDING NAME	NAME	LENGTH	HEIGHT	NOS	
A (RAJIV)	V	0.60	1.20	08	
A (RAJIV)	W1	0.90	1.20	02	
A (RAJIV)	W	1.20	1.20	16	

Buildingwise Floor FAR Details				
Floor Name	Building Name		Total	
	Proposed Built Up Area (Sq.mt.)	Proposed FAR Area (Sq.mt.)	Total Proposed Built Up Area (Sq.mt.)	Total FAR Area (Sq.mt.)
Ground Floor	103.56	103.56	103.56	103.56
First Floor	108.30	105.93	108.30	105.93
Terrace Floor	0.00	0.00	0.00	0.00
Total :	211.86	209.49	211.86	209.49

UnitBUA Table for Building :A (RAJIV)						
FLOOR	Name	UnitBUA Type	UnitBUA Area	Carpet Area	No. of Rooms	No. of Tenement
GROUND FLOOR PLAN	SPLIT A	FLAT	211.86	207.01	8	1
FIRST FLOOR PLAN	SPLIT A	FLAT	0.00	0.00	8	0
Total:	-	-	211.86	207.01	16	1

FAR & Tenement Details (Table 4c-1)							
Building	No. of Same Bldg	Total Built Up Area (Sq.mt.)	Deductions (Area in Sq.mt.)	Proposed FAR Area (Sq.mt.)	Total FAR Area (Sq.mt.)	Total Consumed Additional FAR Area (Sq.mt.)	Tnmt (No.)
A (RAJIV)	1	211.86	2.37	209.49	209.49	209.49	01
Grand Total :	1	211.86	2.37	209.49	209.49	209.49	01

Building USE/SUBUSE Details			
Building Name	Building Use	Building SubUse	Building Structure
A (RAJIV)	Residential	Bungalow/ Dwelling / Non Apartment	Non-Highrise

Balcony Calculations Table			
FLOOR	SIZE	AREA	TOTAL AREA
FIRST FLOOR PLAN	1.20 X 3.95 X 1 X 1	4.74	4.74
Total	-	-	4.74

COLOR INDEX	
PLOT BOUNDARY	
ABUTTING ROAD	
PROPOSED CONSTRUCTION	
COMMON PLOT	
ROAD WIDENING AREA	
EXISTING (To be retained)	
EXISTING (To be demolished)	

LTP NAME AND SIGNATURE	STRUCTURAL ENG'S NAME AND SIGNATURE	BUILDER NAME AND SIGNATURE	DIGITAL SIGNATURE
AMRIT KUMAR MAHATO CMC/DFTM/0004/2019			