

Proposal Basic Information

Proposal File No.	CMC/BP/0158/W17/2023
Owner Name	SHRI RAMKALEBAR PRASAD AND OTHER
Khata No	118
Plot No	165,169
Village Name	Bhawanipur
Use	Residential
SubUse	Bungalow/ Dwelling / Non Apartment

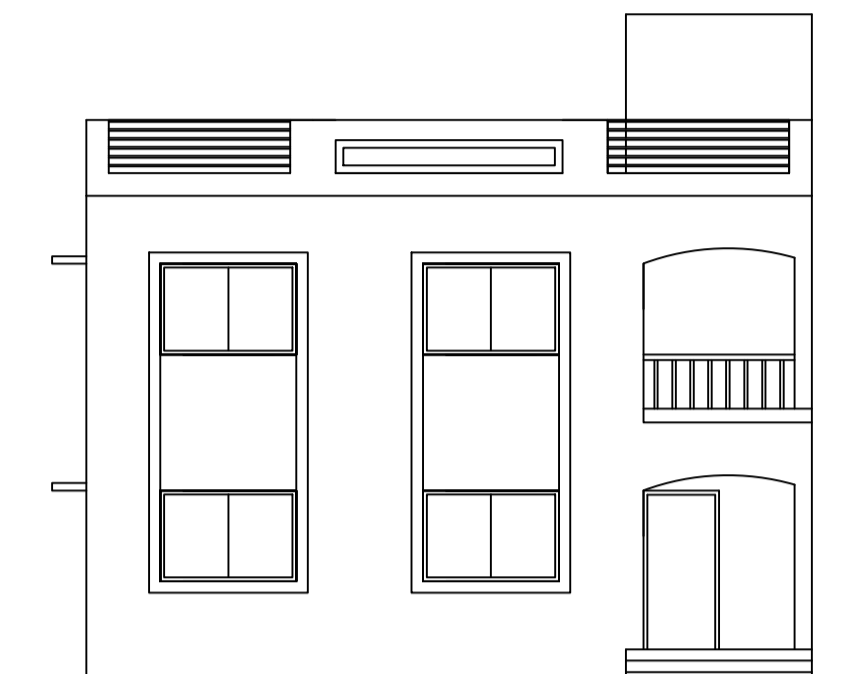

FRONT ELEVATION

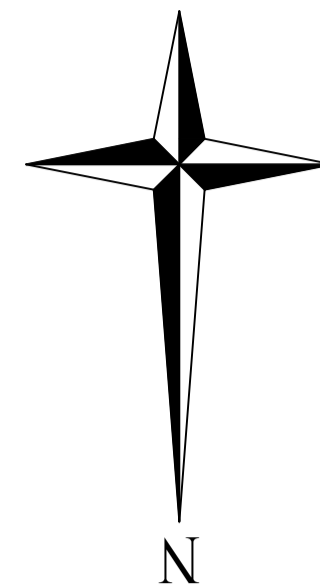
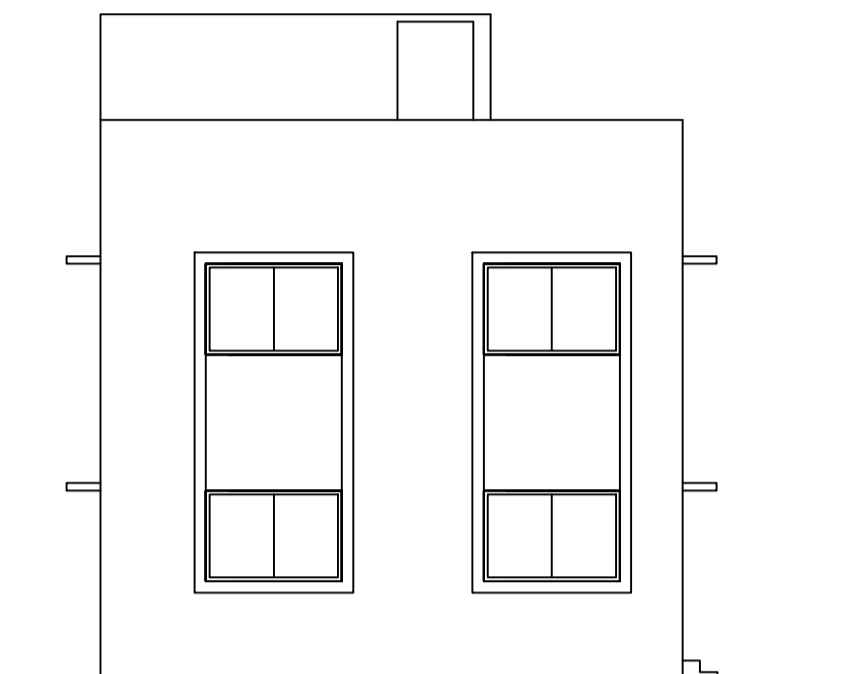

SIDE ELEVATION

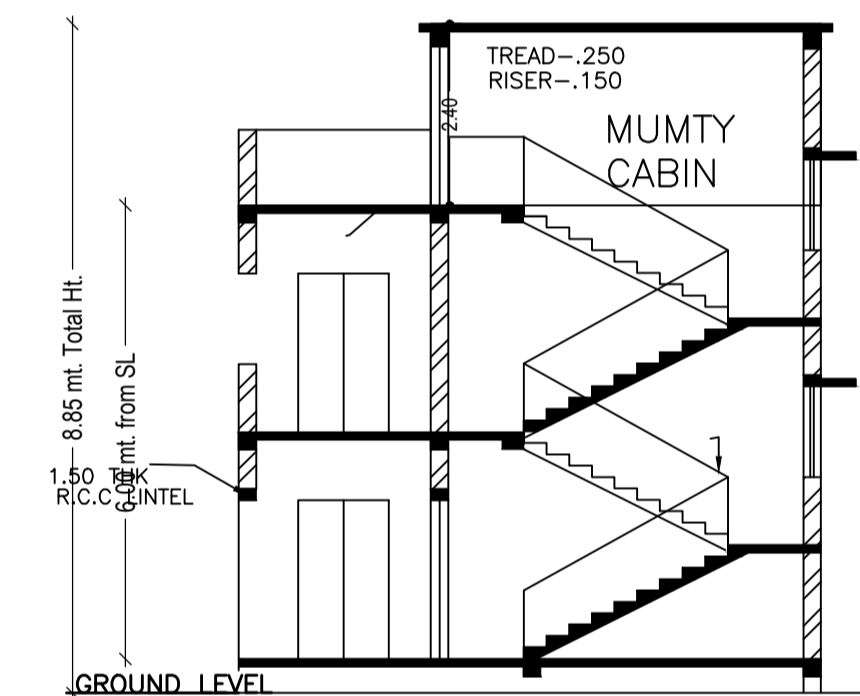
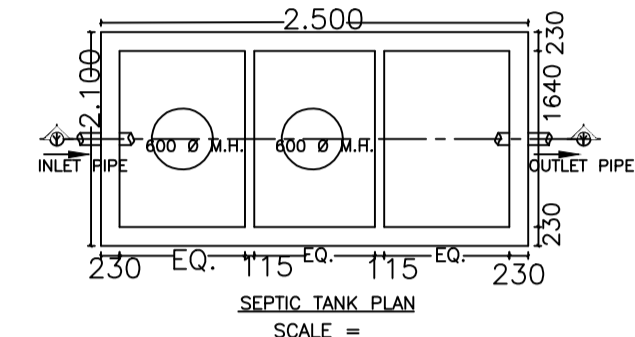
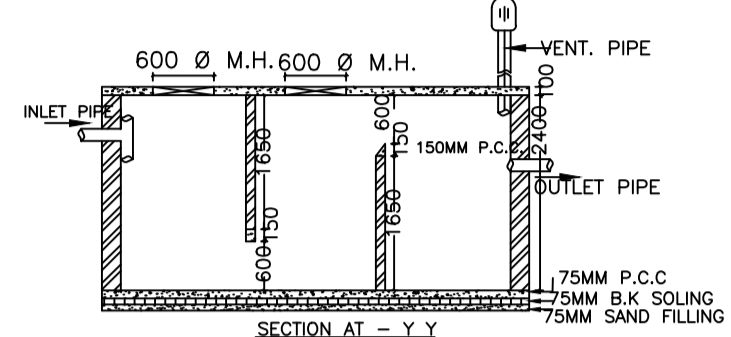
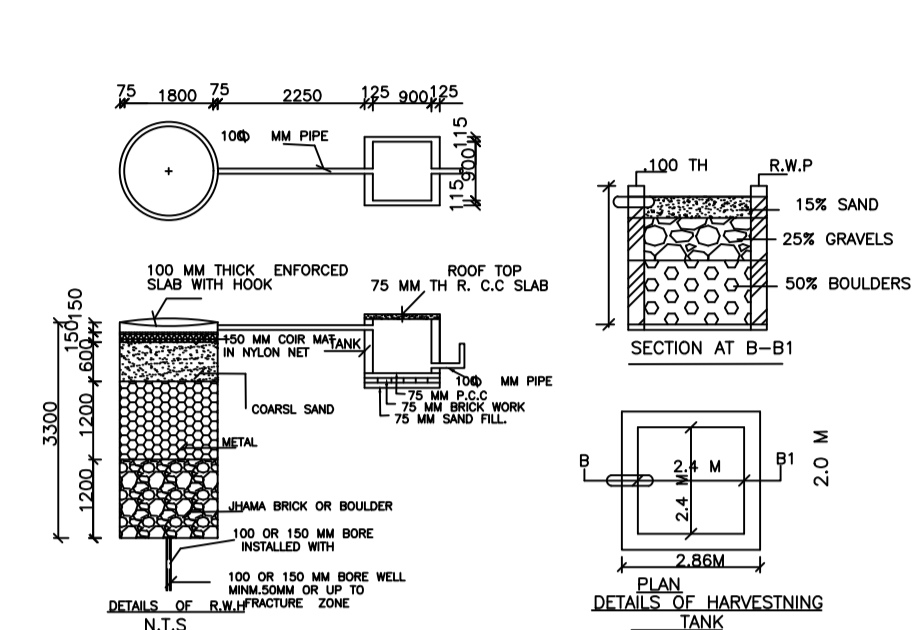

SECTION AT A-A

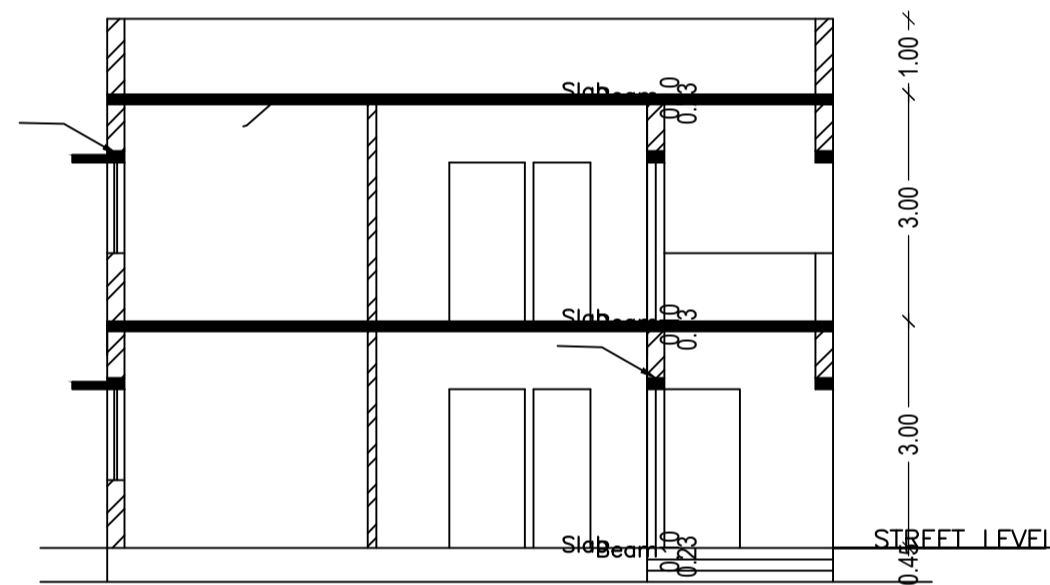

SECTION AT B-B

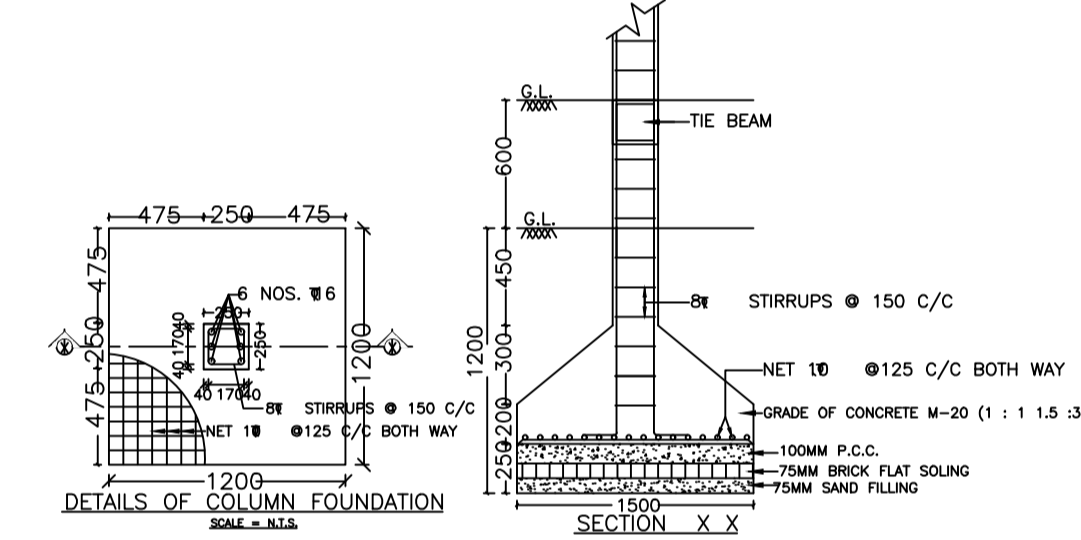

DETAILS OF COLUMN FOUNDATION

SECTION X-X

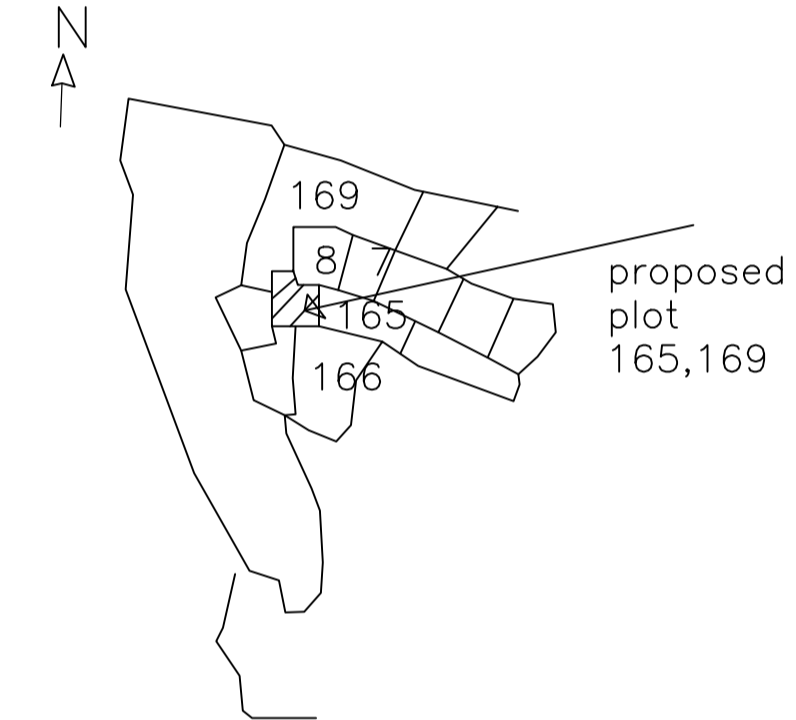
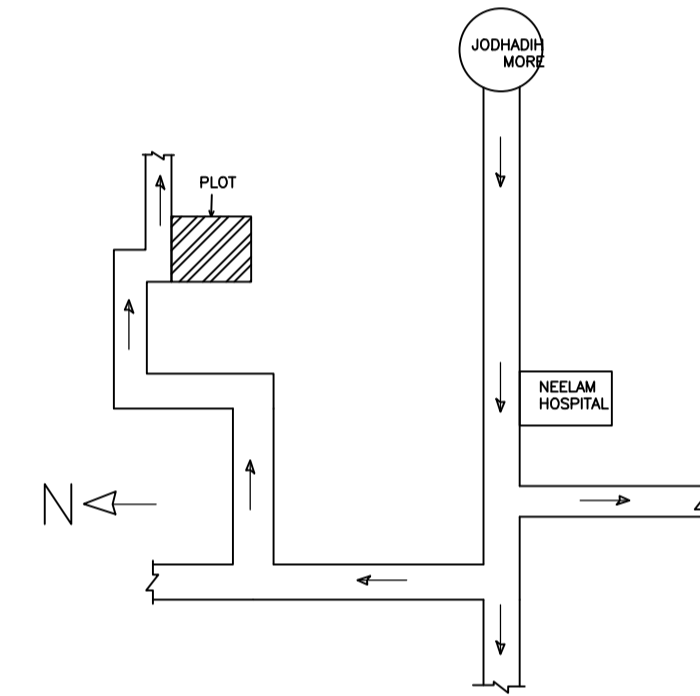

AREA STATEMENT CHAS MUNICIPAL CORPORATION	VERSION NO. 1.0.66	VERSION DATE: 16/10/2020
PROJECT DETAIL:		
Region: JHARKHAND URBAN	Plot Use: Residential	
LOCAL BODIES	Plot SubUse: Bungalow/ Dwelling / Non Apartment	
District: BOKARO	Plot Nearby/Religious/Structure: NA	
Authority: CHAS MUNICIPAL CORPORATION	Plot No: 165,169	
Inward No: CMC/BP/0158/W17/2023	Plot SubPlot No: 165,169	
Application Type: General Proposal	North: Road Width - 4 MTR	
Project Type: Building Permission	South: Plot No. - PLOT NO-160	
Nature of Development: New	East: Plot No. - PLOT NO-166	
Location of Development Area: Old Area	West: Plot No. - PLOT NO-164	
AREA DETAILS:		
AREA OF PLOT (Minimum)	(A)	SO MT
NET AREA OF PLOT (Gross Plot Area - Deduction from Gross Plot Area)	(A-Deductions)	118.72
Deduction for Balance Plot Area (from Gross Plot Area)		7.94
Common Plot		7.94
Total		7.94
BALANCE AREA OF PLOT (Net Plot Area - Recreational/Amenity space)	(A-Deductions)	110.78
PLOT AREA FOR COVERAGE (Net Plot Area)	(A-Deductions)	118.72
Plot Area for FAR (Net Plot Area + Road/Widening Area)	(A-Deductions)	118.72
COVERAGE CHECK		
Permissible Coverage area (70.00 %)		83.10
Proposed Coverage Area (56.44 %)		67.00
Total Prop. Coverage Area (56.44 %)		67.00
Balance coverage area (13.56 %)		16.10
FAR CHECK		
Perm. FAR Area (1.500)		178.08
Total Perm. FAR area		178.08
Residential FAR		134.00
Total Proposed FAR Area		134.00
Consumed FAR (Factor)		1.13
Balance FAR Area		44.08
BUILT UP AREA CHECK		
Total Proposed Built Up Area		134.00
ARCHITECT (Regd)		RAGHUNATH MAHATO
ENGINEER (Regd)		
SUPERVISOR (Regd)		
OWNER (Regd)		SHRI RAMKALEBAR PRASAD AND OTHER
DEVELOPMENT AUTHORITY		LOCAL BODY

Building :RP (BUILDING)					
Floor Name	Total Built Up Area (Sq.mt.)	Proposed FAR Area (Sq.mt.)	Total FAR Area (Sq.mt.)	Total Consumed Additional FAR Area (Sq.mt.)	Trent (No.)
Ground Floor	67.00	67.00	67.00	67.00	01
First Floor	67.00	67.00	67.00	67.00	00
Terrace Floor	0.00	0.00	0.00	0.00	00
Total	134.00	134.00	134.00	134.00	01
Total Number of Same Buildings	1				
Total	134.00	134.00	134.00	134.00	01

SCHEDULE OF DOOR:				
BUILDING NAME	NAME	LENGTH	HEIGHT	NOS
RP (BUILDING)	D3	0.75	2.10	02
RP (BUILDING)	D2	0.90	2.10	02
RP (BUILDING)	D1	1.00	2.10	08
RP (BUILDING)	D	1.20	2.10	02
SCHEDULE OF WINDOW/VENTILATION:				
BUILDING NAME	NAME	LENGTH	HEIGHT	NOS
RP (BUILDING)	V	0.75	0.60	02
RP (BUILDING)	W1	1.20	1.20	05
RP (BUILDING)	W	1.50	1.20	10

UnitBUA Table for Building :RP (BUILDING)						
FLOOR	Name	UnitBUA Type	UnitBUA Area	Carpet Area	No. of Rooms	No. of Tenement
GROUND FLOOR	SPLIT RP	FLAT	102.22	99.61	6	1
FIRST FLOOR	SPLIT RP	FLAT	0.00	0.00	6	0
Total	-	-	102.22	99.61	12	1

Buildingwise Floor FAR Details				
Floor Name	Proposed Built Up Area (Sq.mt.)	Proposed FAR Area (Sq.mt.)	Total Proposed Built Up Area (Sq.mt.)	Total FAR Area (Sq.mt.)
Ground Floor	67.00	67.00	67.00	67.00
First Floor	67.00	67.00	67.00	67.00
Terrace Floor	0.00	0.00	0.00	0.00
Total	134.00	134.00	134.00	134.00

FAR & Tenement Details (Table 4c-1)						
Building	No. of Same Bldg	Total Built Up Area (Sq.mt.)	Proposed FAR Area (Sq.mt.)	Total FAR Area (Sq.mt.)	Total Consumed Additional FAR Area (Sq.mt.)	Trent (No.)
RP (BUILDING)	1	134.00	134.00	134.00	134.00	01
Grand Total	1	134.00	134.00	134.00	134.00	01

Building USE/SUBUSE Details			
Building Name	Building Use	Building SubUse	Building Structure
RP (BUILDING)	Residential	Bungalow/ Dwelling / Non Apartment	Non-Highrise

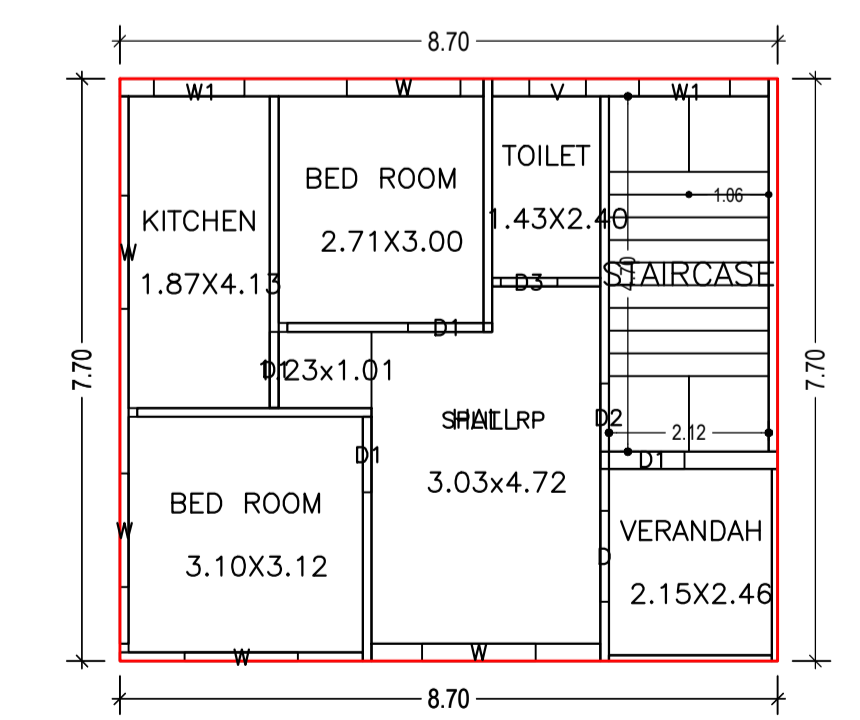

GROUND FLOOR PLAN (Proposed) (SCALE 1:100)

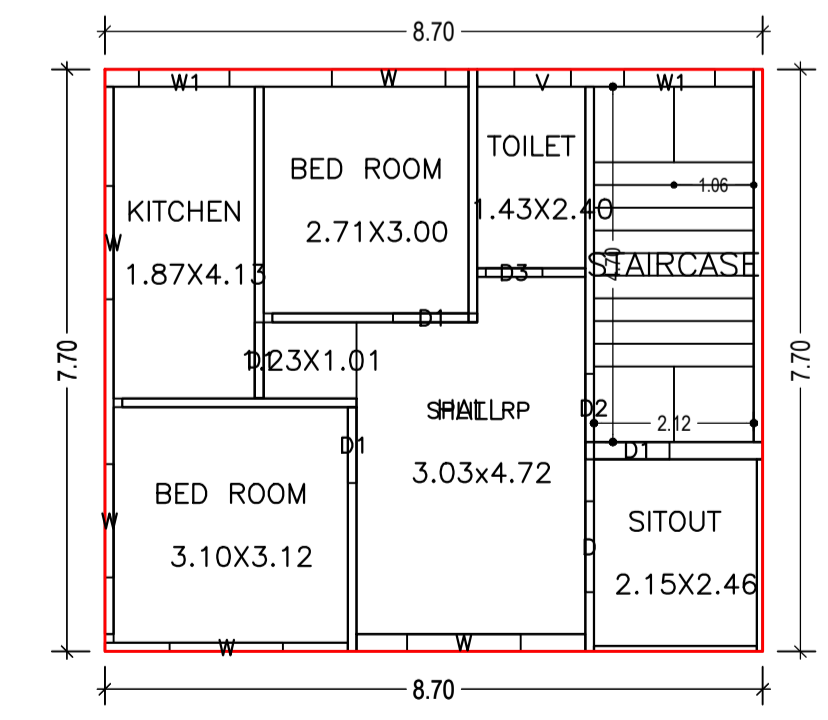

FIRST FLOOR PLAN (Proposed) (SCALE 1:100)

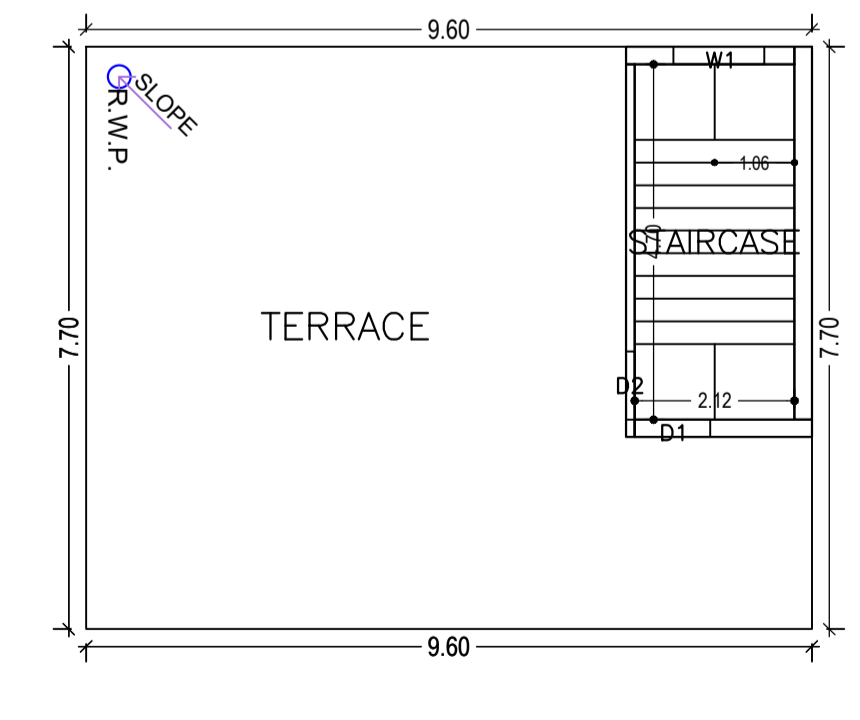

TERRACE FLOOR PLAN (SCALE 1:100)

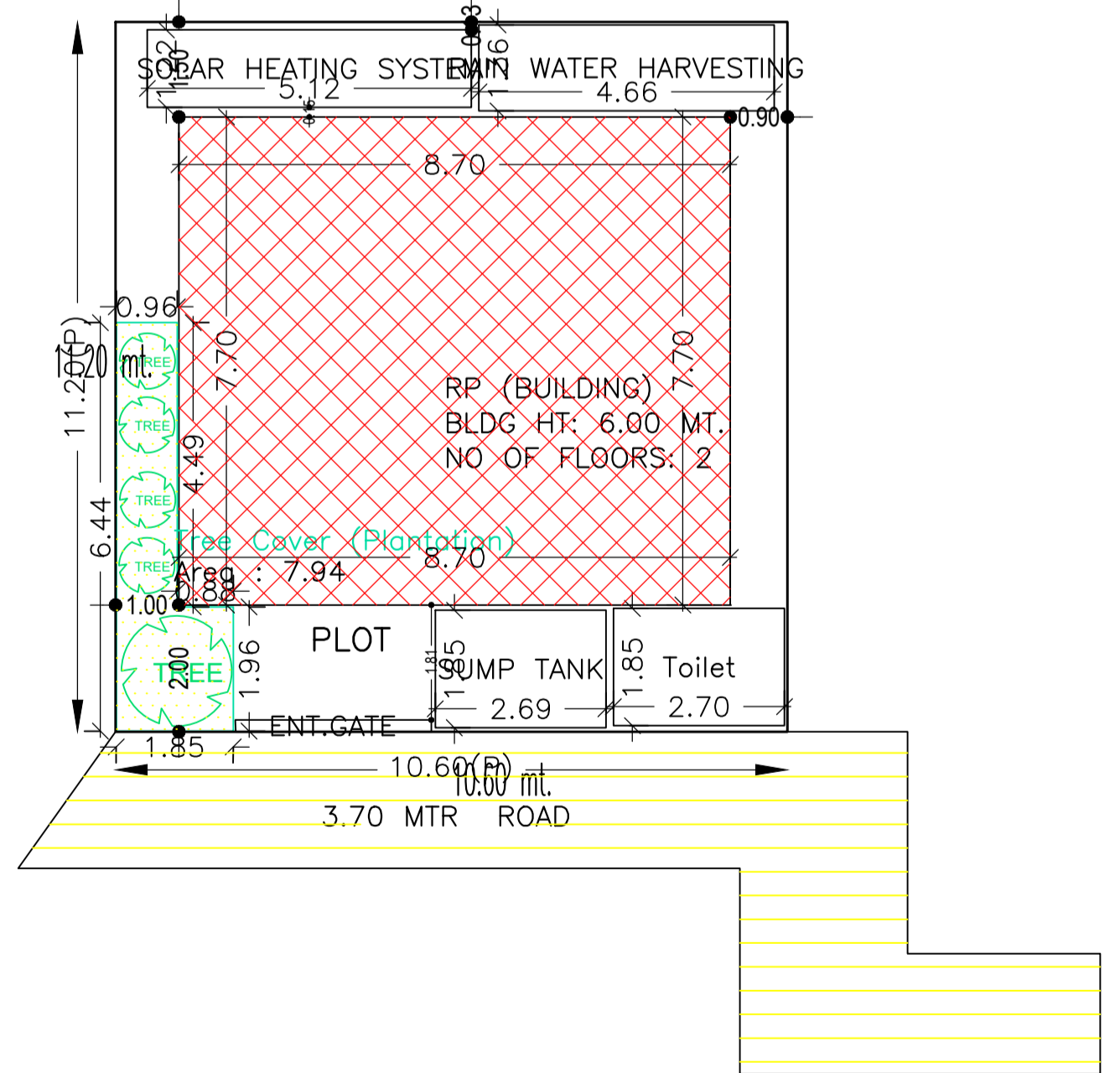

SITE PLAN

COLOR INDEX	
PLOT BOUNDARY	Black
ABUTTING ROAD	Red
PROPOSED CONSTRUCTION COMMON PLOT	Green
ROAD WIDENING AREA	Yellow
EXISTING (To be retained)	Blue
EXISTING (To be demolished)	Orange

LTP NAME AND SIGNATURE	STRUCTURAL ENG'S NAME AND SIGNATURE	BUILDER NAME AND SIGNATURE	DIGITAL SIGNATURE
RAGHUNATH MAHATO CMC/DFTM/0033/2017			