

Project Title :SHRI RAMKAIL ESHWAR PRASAD

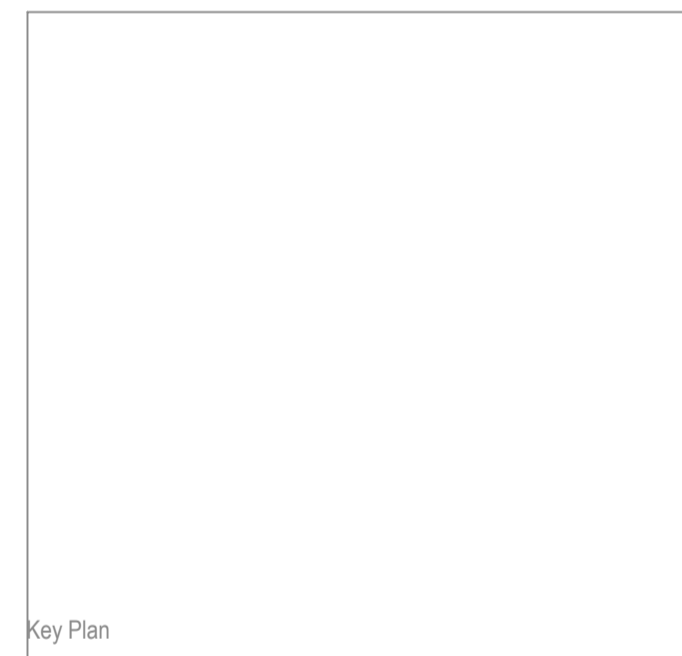
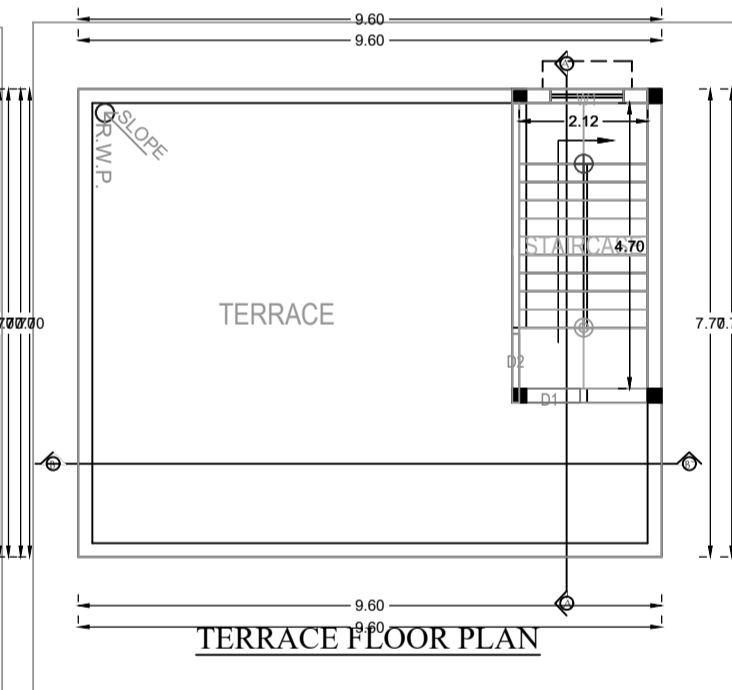
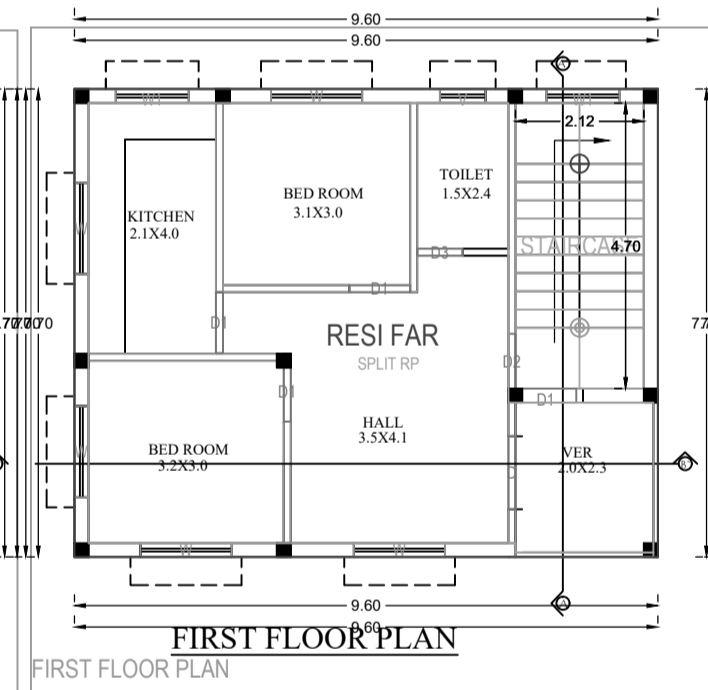
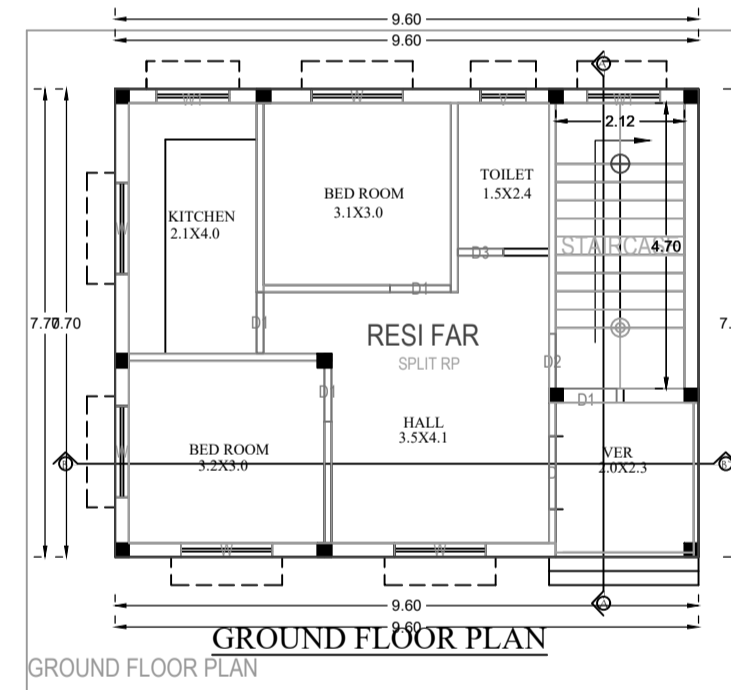
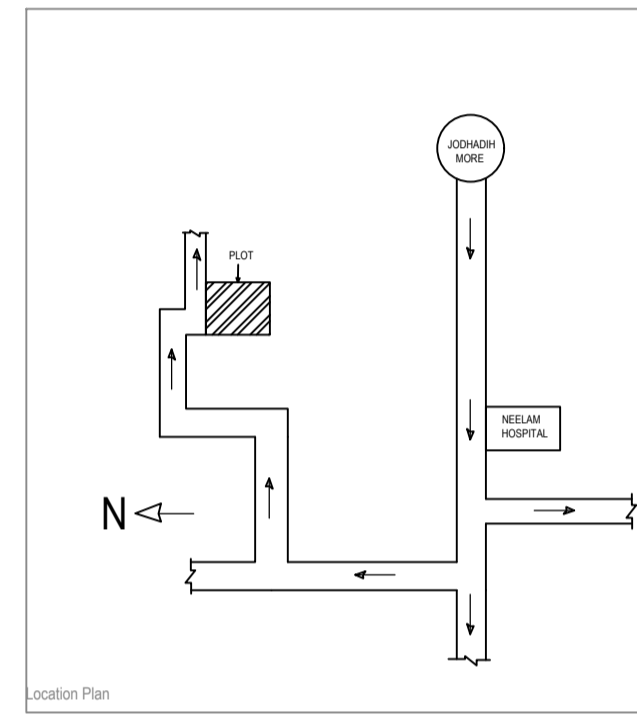
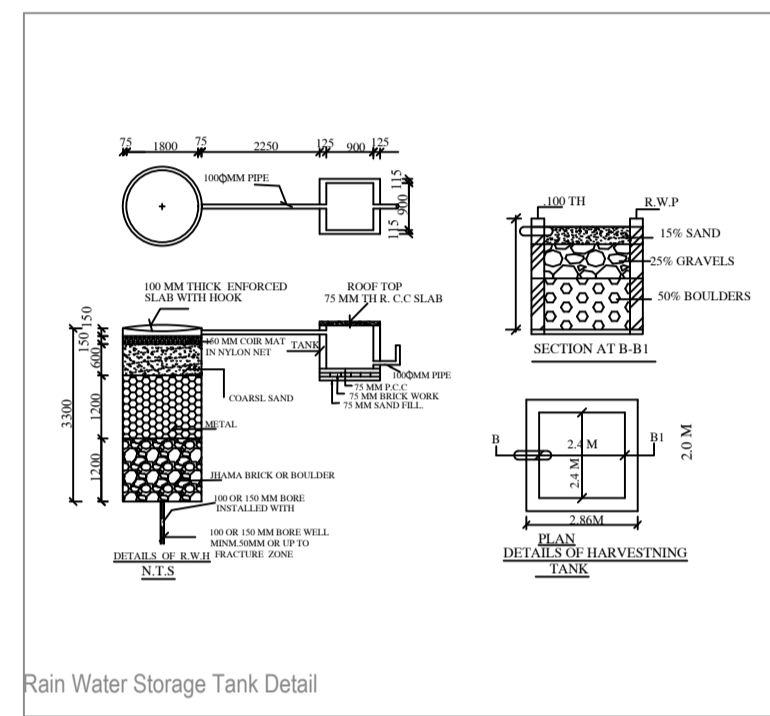
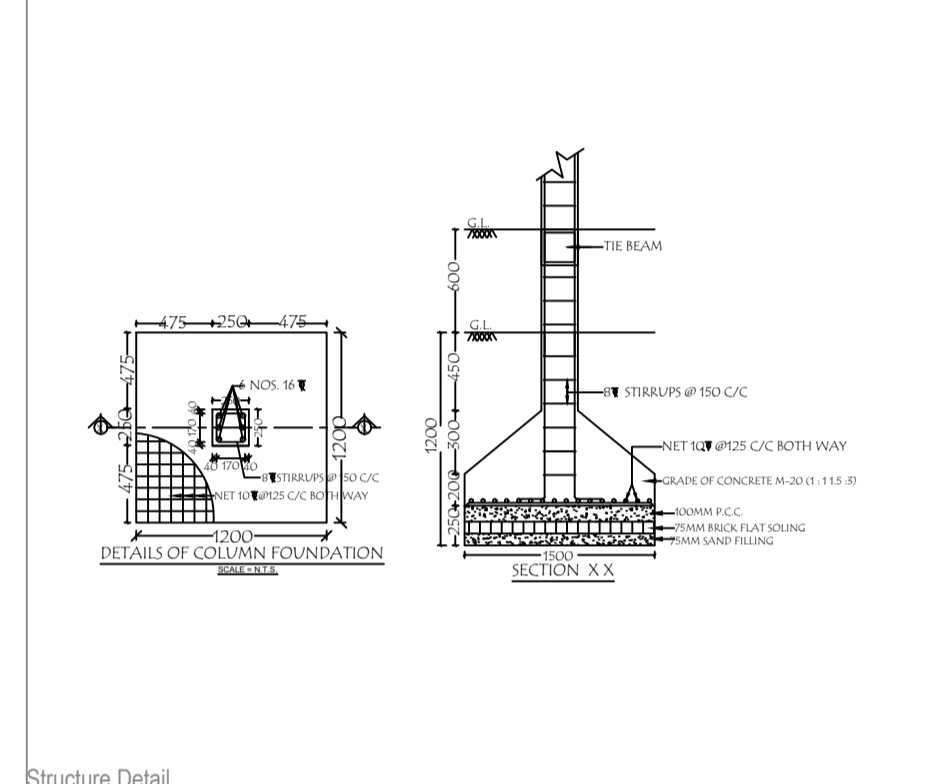
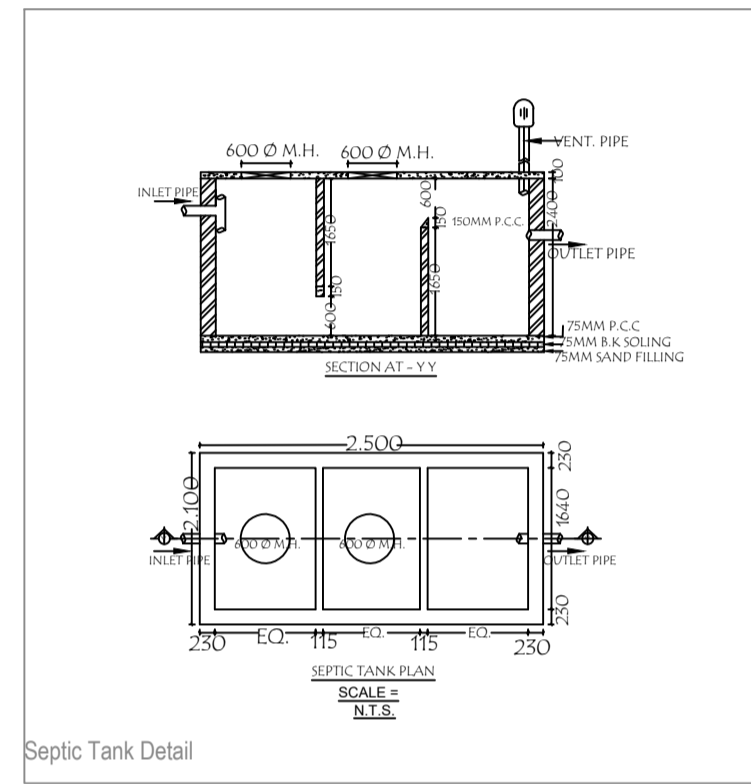
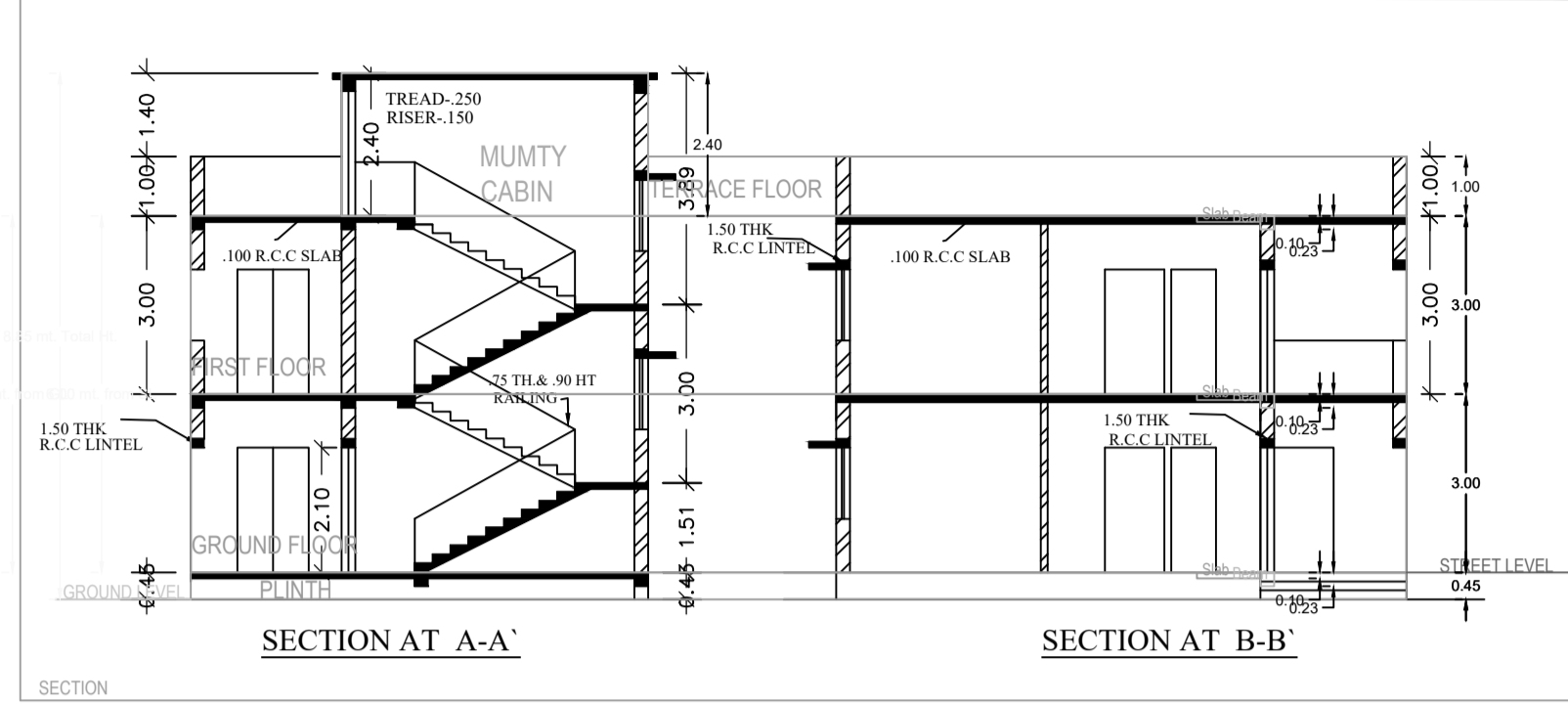
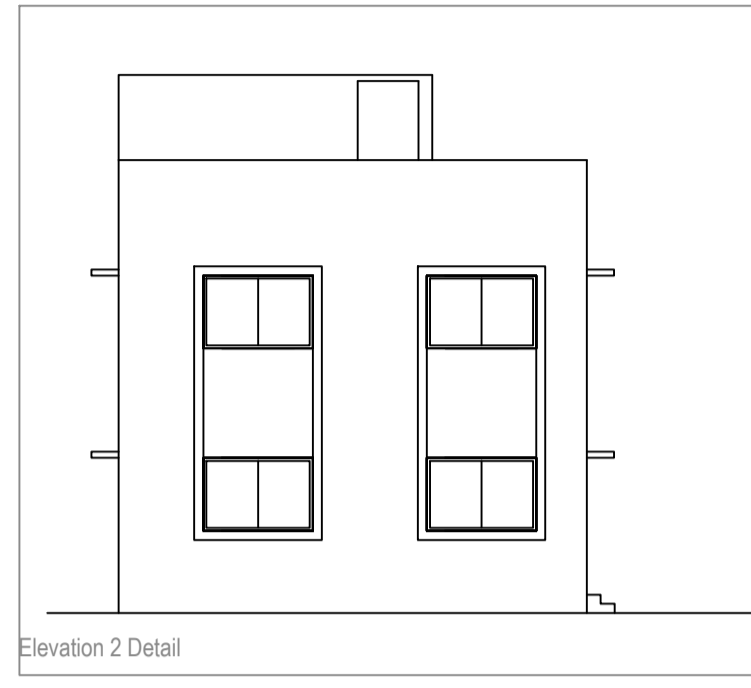
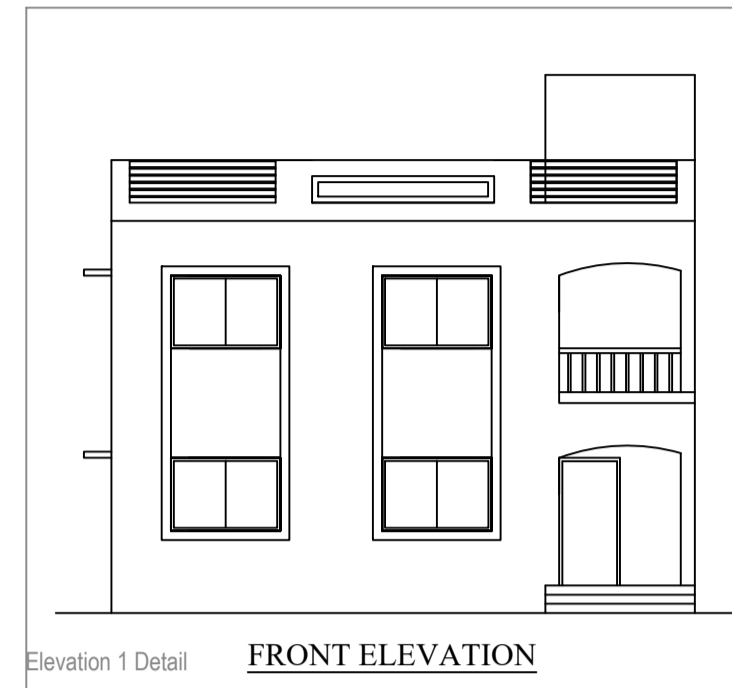

Building :RP (BUILDING)

Floor Name	Total Built Up Area (Sq.mt.)	Proposed FAR Area (Sq.mt.)	Total FAR Area (Sq.mt.)	Tnmt (No.)
Ground Floor...	73.92	73.92	73.92	01
First Floor...	73.92	73.92	73.92	00
Terrace Floor...	0.00	0.00	0.00	00
Total	147.84	147.84	147.84	01
Total Number of Same Buildings	1	147.84	147.84	01

SCHEDULE OF JOINERY:

BUILDING NAME	NAME	LENGTH	HEIGHT	NOS
RP (BUILDING)	D3	0.75	2.10	02
RP (BUILDING)	D2	0.90	2.10	03
RP (BUILDING)	D1	1.00	2.10	09
RP (BUILDING)	D	1.20	2.10	02
Total	-	-	-	16

SCHEDULE OF JOINERY:

BUILDING NAME	NAME	LENGTH	HEIGHT	NOS
RP (BUILDING)	V	0.75	1.00	02
RP (BUILDING)	W1	1.20	1.20	05
RP (BUILDING)	W	1.50	1.20	10
Total	-	-	-	17

UnitBUA Table for Building :RP (BUILDING)

FLOOR	Name	UnitBUA Type	UnitBUA Area	Carpet Area	No. of Rooms	No. of Tenement
GROUND FLOOR PLAN	SPLIT RP	FLAT	111.78	107.60	6	1
Total	-	-	111.78	107.60	12	1

AREA STATEMENT: CHAS MUNICIPAL CORPORATION	VERSION NO: 1.0.36	
PROJECT DETAIL:	VERSION DATE: 16/10/2020	
Inward No.:	Plot Use: Residential	
Region: BHARHAT URBAN LOCAL BODIES	Plot SubUse: Bungalow/ Dwelling / Non Apartment	
District: BHARHAT	Land Use Zone: Residential	
Application Type: General Proposal	Abutting Road Width: -	
Project Type: Building Permission	Plot No.:	
Nature of Development: New	Revenue Survey No/Survey No: -	
Location: Old Area	Thana No: -	
Sub Location: NA	Holding No: -	
Village/Mauza Name: -	Khata No: -	
Ward No: -	North: -	
Road/Street: -	East: -	
	West: -	
AREA DETAILS:	SQ.MT.	
AREA OF PLOT (Minimum)	(A)	118.72
Net Plot Area (Gross Plot Area - Deduction from Gross Plot Area)	(A-Deductions)	118.72
Deductions for Balance Plot Area (from Gross Plot Area)		
COF Area		7.94
Total		7.94
Balance Plot Area (Net Plot Area - Recreational/Amenity space)	(A-Deductions)	110.78
Plot Area for Coverage (Net Plot Area)	(A-Deductions)	118.72
Plot Area for FSI (Net Plot Area + Road Widening Area)	(A-Deductions)	118.72
Accessory Use Area		4.99
COVERAGE CHECK		
Proposed Coverage Area (62.26 %)		73.92
Total Coverage Area (62.26 %)		73.92
FAR CHECK		
Proposed Area of FAR		147.84
Total Area of FAR		147.84
BUILT UP AREA CHECK		
Total Proposed Built Up Area		147.84
ARCH / ENGG / SUPERVISOR (Regd)		OWNER
DEVELOPMENT AUTHORITY		LOCAL BODY

COLOR INDEX

PLOT BOUNDARY	██████████
ABUTTING ROAD	██████████
PROPOSED WORK (COVERAGE AREA)	██████████
EXISTING (To be retained)	██████████
EXISTING (To be demolished)	██████████

MARGIN DETAIL:

Building / Wing Name	Road Name	Front Margin	Rear Margin	Side1 Margin	Side2 Margin
RP-1 (BUILDING)	4 MTR ROAD	2.00	1.50	1.00	0.00

FAR & Tenement Details (Table 4c-1)

Building	No. of Same Bldg	Total Built Up Area (Sq.mt.)	Proposed FAR Area (Sq.mt.)	Total FAR Area (Sq.mt.)	Tnmt (No.)
RP (BUILDING)	1	147.84	147.84	147.84	01
Grand Total:	1	147.84	147.84	147.84	01

