

Proposal Basic Information	
Proposal File No.	CMC/BP/0239/W17/2023
Owner Name	SMT RENU KUMARI
Khata No	66
Plot No	3772
Village Name	Chas
Use	Residential
SubUse	Bungalow/ Dwelling / Non Apartment

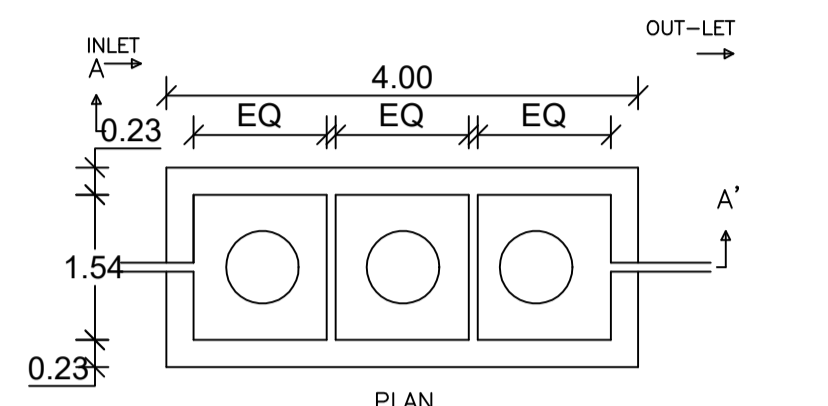

DETAILS OF SEPTIC TANK

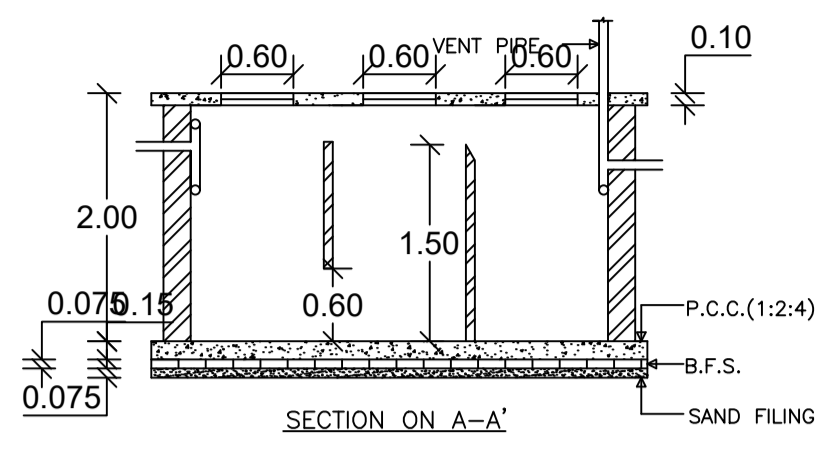
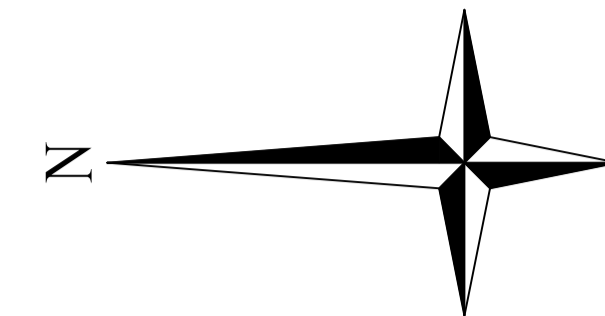
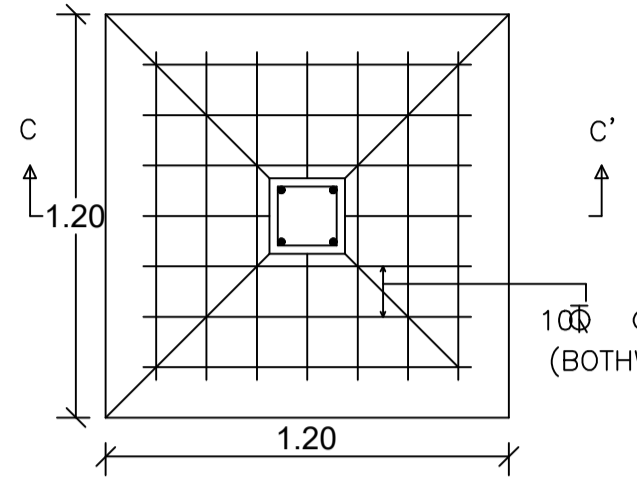

DETAILS OF FOUNDATION

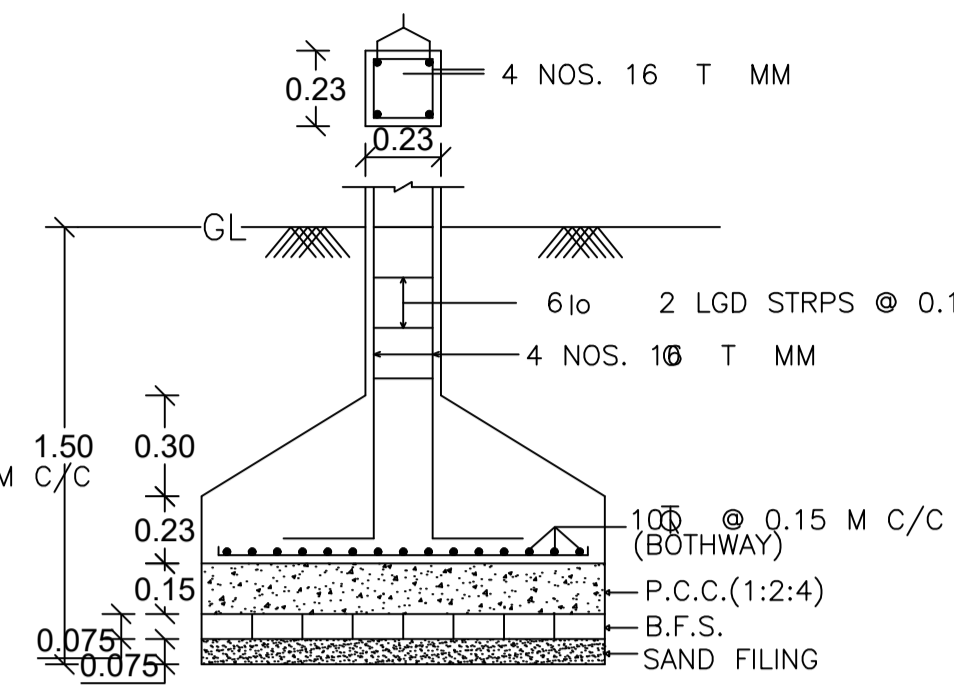

SECTION ON C-C'

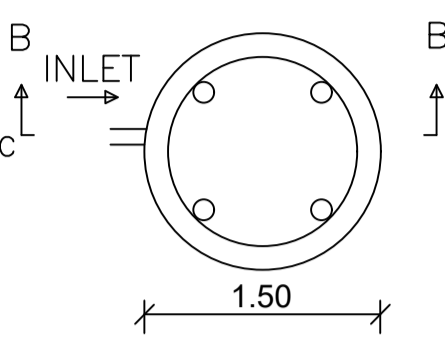

DETAILS OF WATER HARVESTING

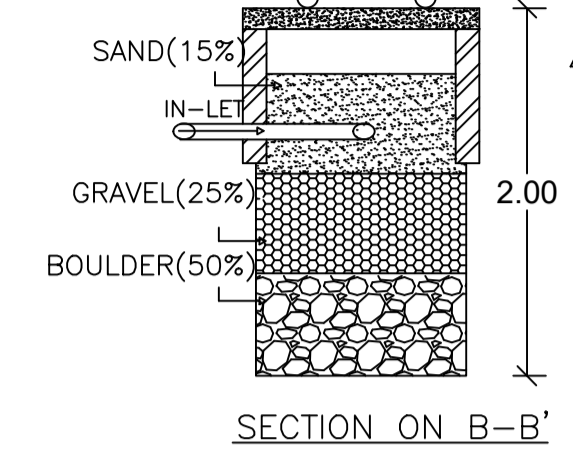

SECTION ON B-B'

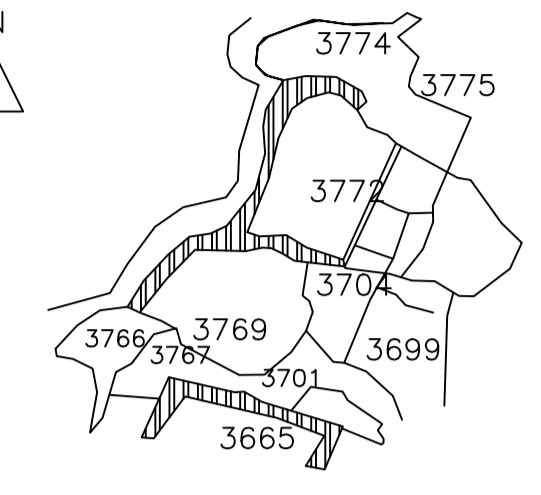

KEY MAP

AREA STATEMENT CHAS MUNICIPAL CORPORATION		VERSION NO. 1.0.66	VERSION DATE: 16/10/2020
PROJECT DETAIL:			
Region: JHARKHAND URBAN LOCAL BODIES	Plot Use: Residential		
District: BOKARO	Plot SubUse: Bungalow/ Dwelling / Non Apartment		
Authority: CHAS MUNICIPAL CORPORATION	PlotNearbyReligiousStructure: NA		
Inward_No: CMC/BP/0239/W17/2023	Plot/SubPlot No: 3772		
Application Type: General Proposal	North: Plot No. - PLOTING NO.-E/3 MARK LAND		
Project Type: Building Permission	South: Plot No. - PLOT NO. - 3700		
Nature of Development: New	East: Plot No. - PLOTING NO.-E/2 MARK LAND		
Location of Development Area: Old Area	West: Road Width - ROAD		
AREA DETAILS:			
AREA OF PLOT (Minimum)	(A)		SQ.MT. 202.03
NET AREA OF PLOT(Gross Plot Area - Deduction from Gross Plot area)	(A-Deductions)		202.03
Deduction for Balance Plot Area(from Gross Plot Area)			
Common Plot			19.23
Total			19.23
BALANCE AREA OF PLOT(Net Plot Area - Recreational/Amenity space)	(A-Deductions)		182.80
PLOT AREA FOR COVERAGE(Net Plot Area)	(A-Deductions)		202.03
Plot Area for FAR (Net Plot Area + Road Widening Area)	(A-Deductions)		202.03
COVERAGE CHECK			
Permissible Coverage area (70.00 %)			141.42
Proposed Coverage Area (51.05 %)			103.14
Total Prop. Coverage Area (51.05 %)			103.14
Balance coverage area (18.95 %)			38.28
FAR CHECK			
Perm. FAR area (1.500)			303.04
Total Perm. FAR area			303.04
Residential FAR			206.28
Proposed FAR Area			206.28
Total Proposed FAR Area			206.28
Consumed FAR (Factor)			1.02
Balance FAR Area			96.76
BUILT UP AREA CHECK			
Total Proposed BuiltUp Area			206.28
ARCHITECT (Regd)			AMRIT KUMAR MAHATO
ENGINEER (Regd)			
SUPERVISOR (Regd)			
OWNER (Regd)			SMT RENU KUMARI
DEVELOPMENT AUTHORITY		LOCAL BODY	

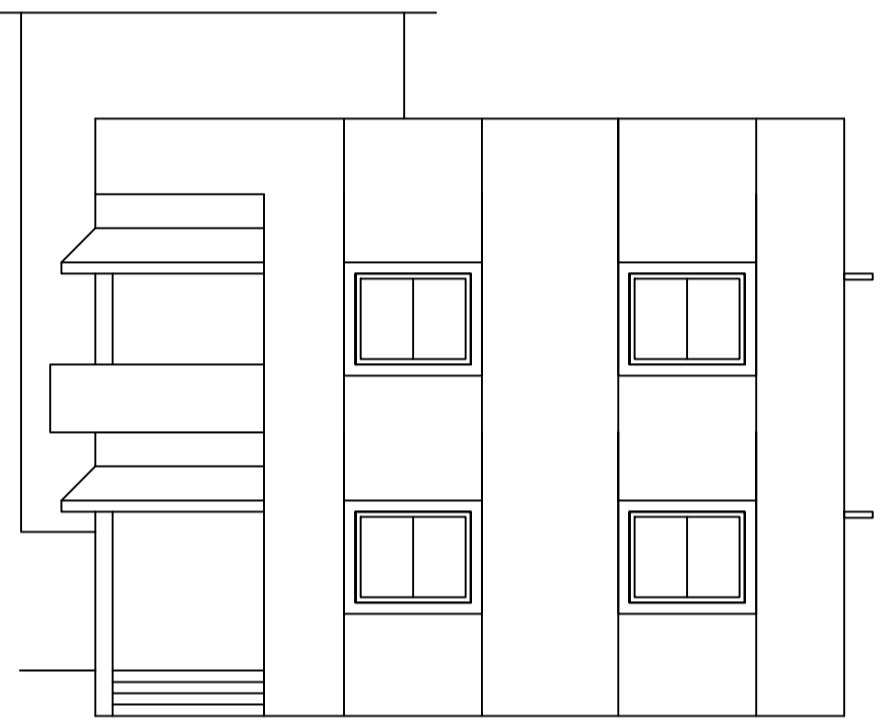

FRONT ELEVATION

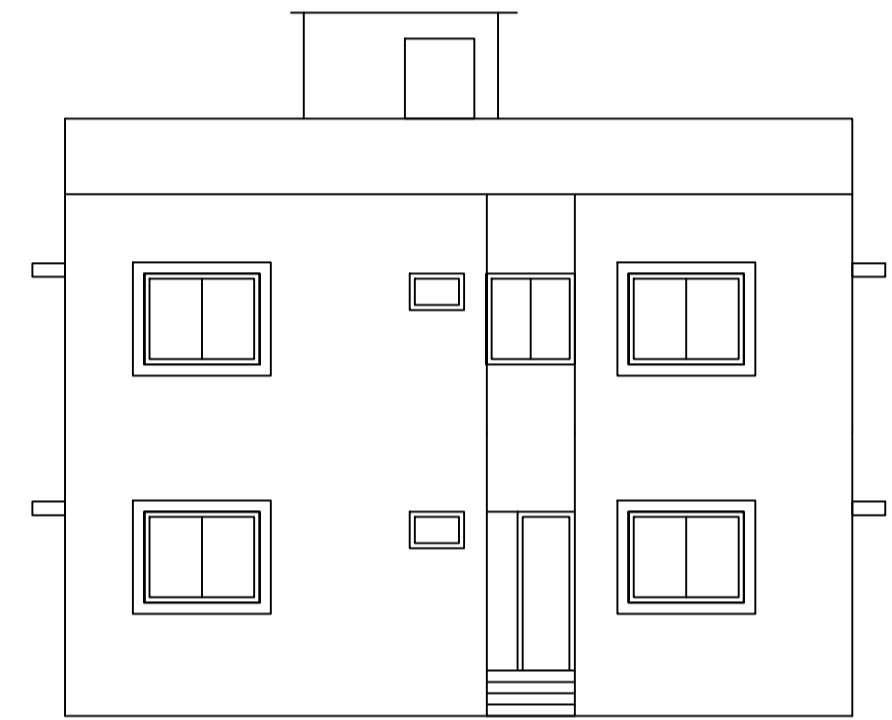

SIDE ELEVATION

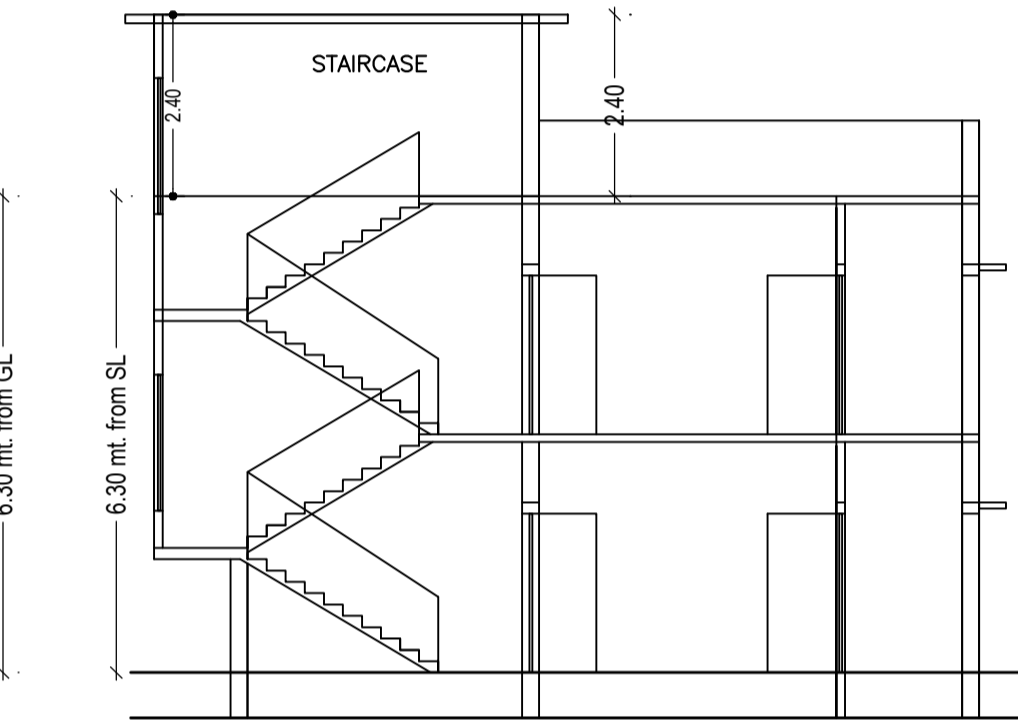

SECTION ON X-X'

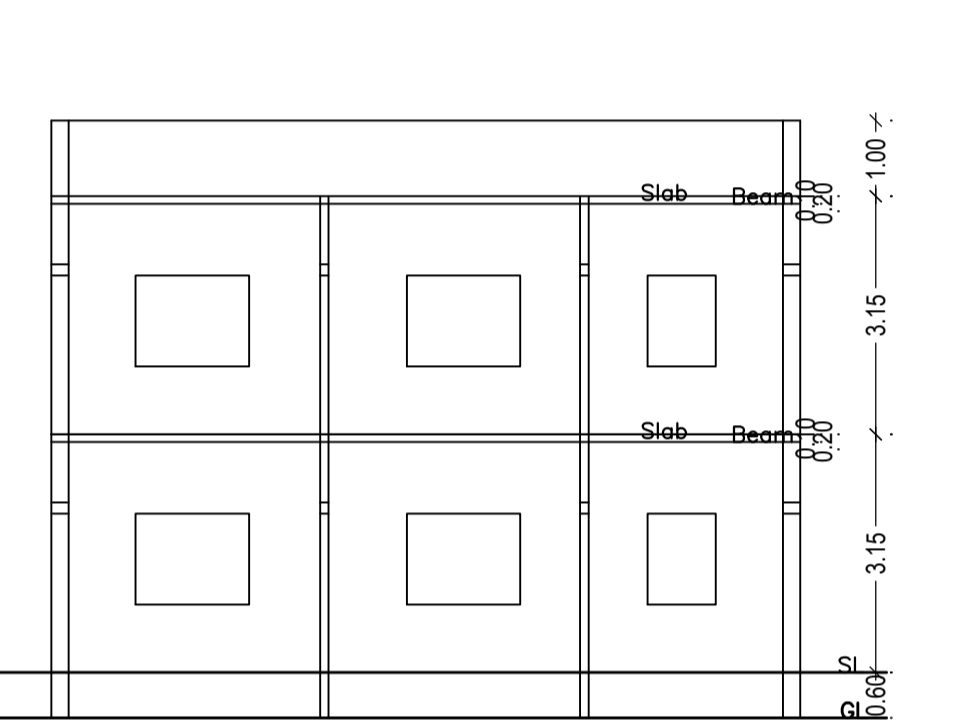

SECTION ON Y-Y'

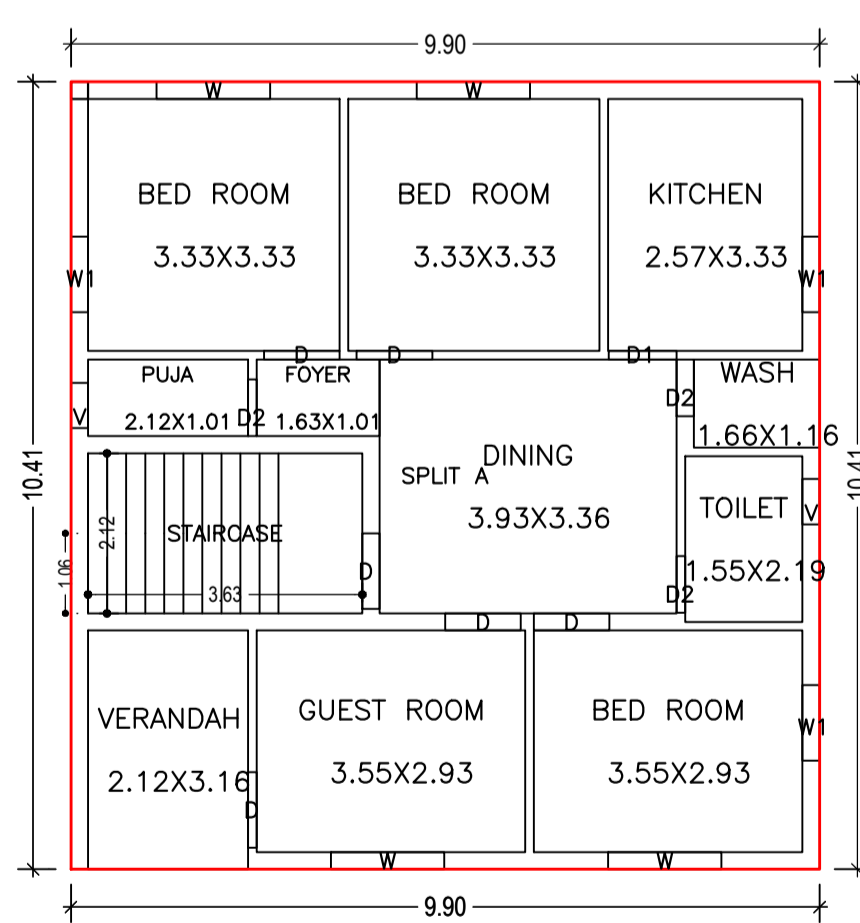

GROUND FLOOR PLAN (Proposed) (SCALE 1:100)

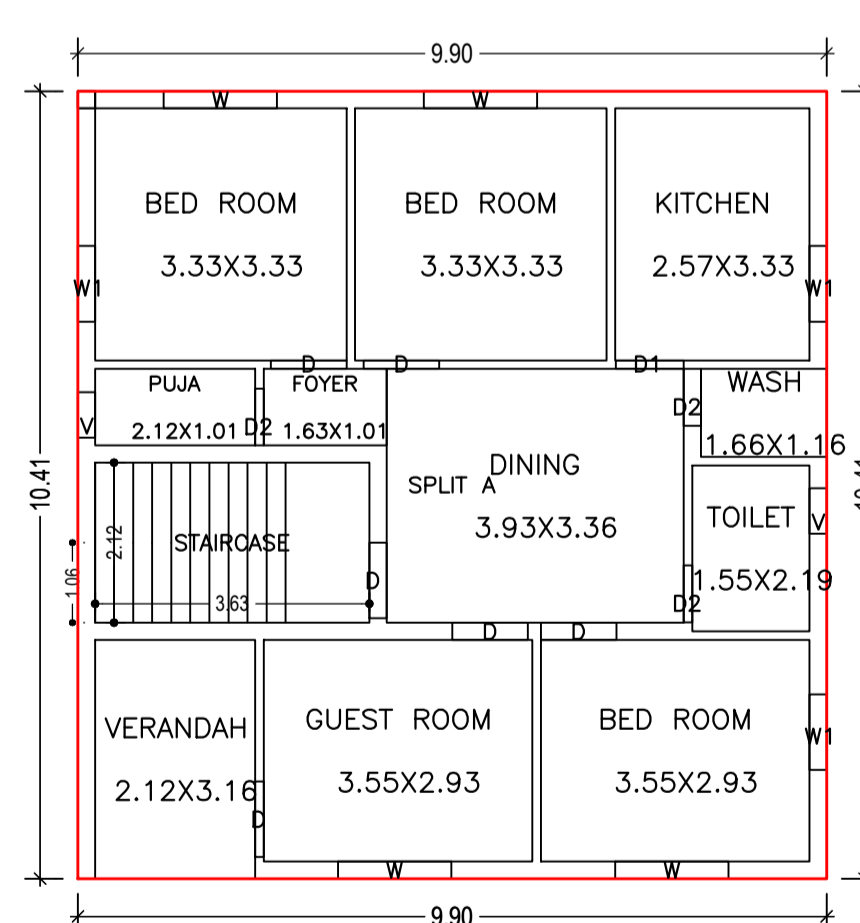

FIRST FLOOR PLAN (Proposed) (SCALE 1:100)

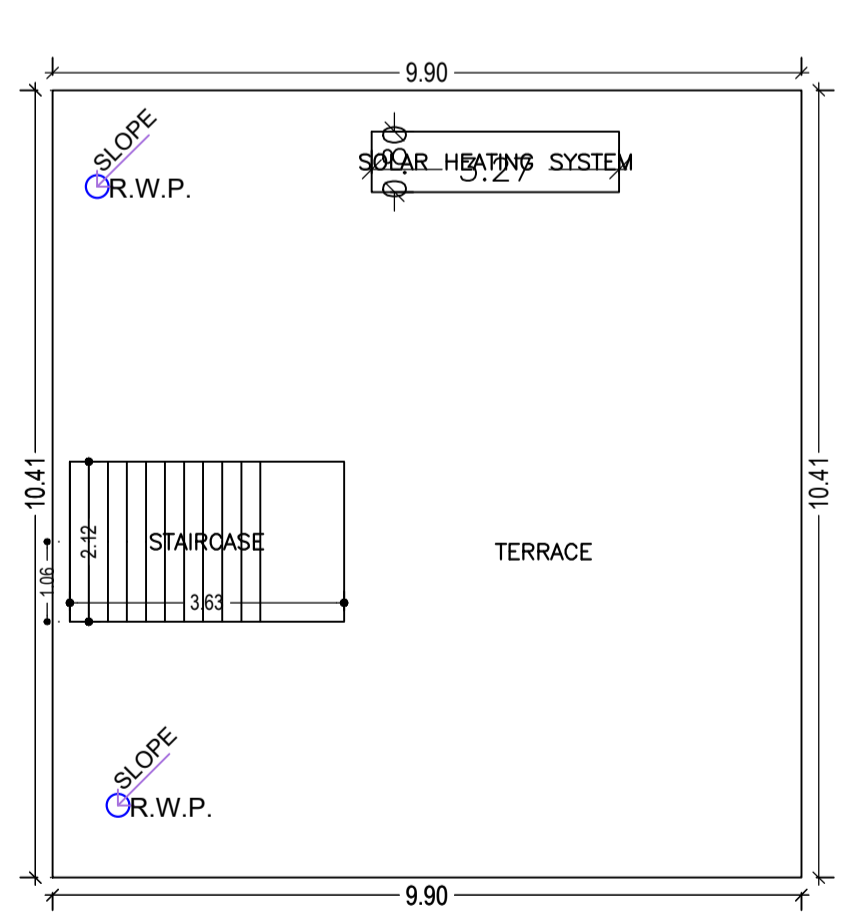

TERRACE FLOOR PLAN (SCALE 1:100)

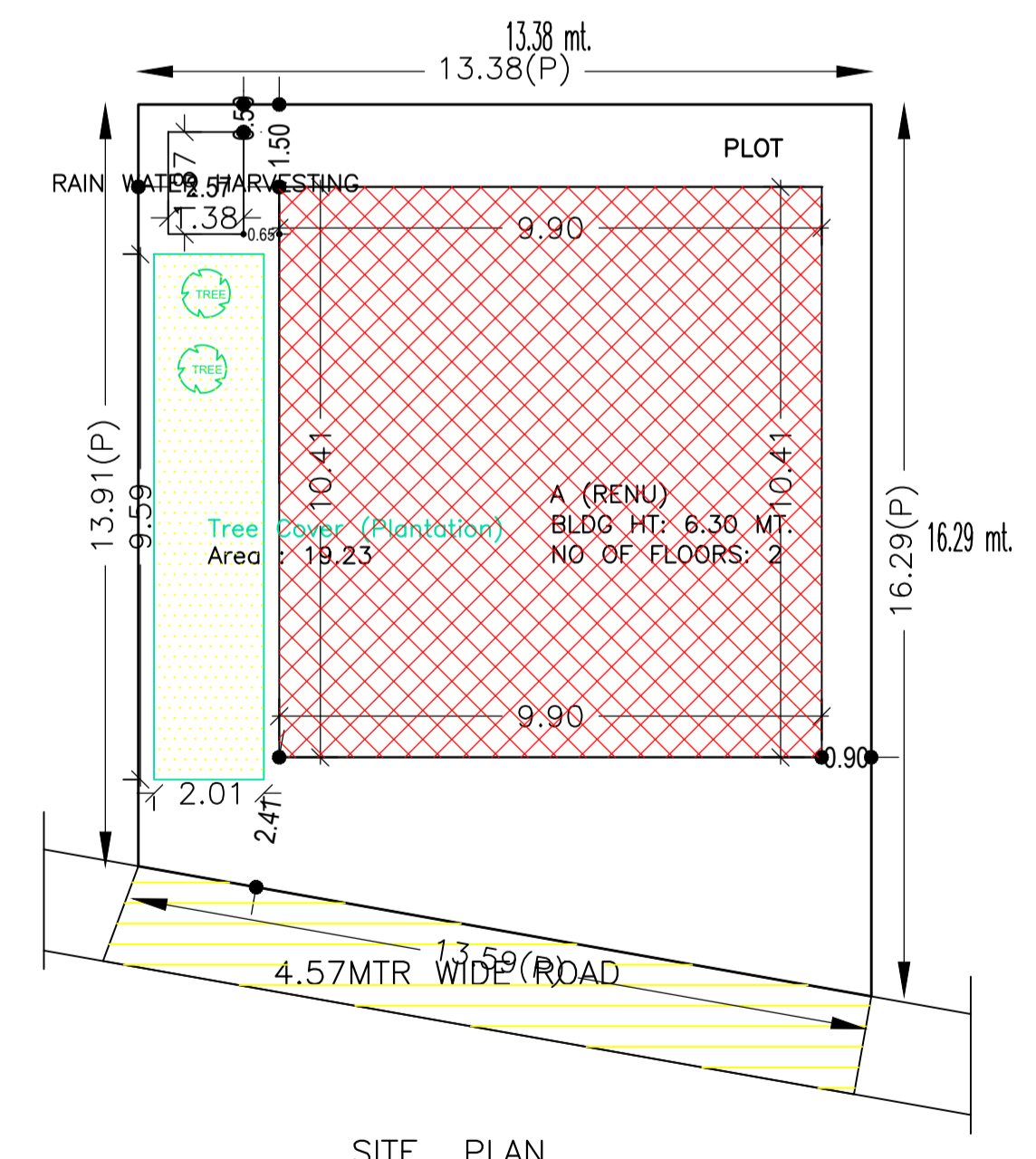

SITE PLAN

SCHEDULE OF DOOR:

BUILDING NAME	NAME	LENGTH	HEIGHT	NOS
A (RENU)	D2	0.75	2.10	06
A (RENU)	D1	0.90	2.10	02
A (RENU)	D	1.00	2.10	12

SCHEDULE OF WINDOW/VENTILATION:

BUILDING NAME	NAME	LENGTH	HEIGHT	NOS
A (RENU)	V	0.60	0.60	04
A (RENU)	W1	1.00	1.20	06
A (RENU)	W	1.50	1.20	08

Building :A (RENU)

Floor Name	Total Built Up Area (Sq.mt.)	Proposed FAR Area (Sq.mt.) Resi.	Total FAR Area (Sq.mt.)	Total Consumed Additional FAR Area (Sq.mt.)	Tnmt (No.)
Ground Floor	103.14	103.14	103.14	103.14	01
First Floor	103.14	103.14	103.14	103.14	00
Terrace Floor	0.00	0.00	0.00	0.00	00
Total :	206.28	206.28	206.28	206.28	01
Total Number of Same Buildings :	1				
Total :	206.28	206.28	206.28	206.28	01

Buildingwise Floor FAR Details

Floor Name	Building Name A (RENU)		Total	
	Proposed Built Up Area (Sq.mt.)	Proposed FAR Area (Sq.mt.)	Total Proposed Built Up Area (Sq.mt.)	Total FAR Area (Sq.mt.)
Ground Floor	103.14	103.14	103.14	103.14
First Floor	103.14	103.14	103.14	103.14
Terrace Floor	0.00	0.00	0.00	0.00
Total :	206.28	206.28	206.28	206.28

UnitBUA Table for Building :A (RENU)

FLOOR	Name	UnitBUA Type	UnitBUA Area	Carpert Area	No. of Rooms	No. of Tenement
GROUND FLOOR PLAN	SPLIT A	FLAT	206.28	206.17	11	1
FIRST FLOOR PLAN	SPLIT A	FLAT	0.00	0.00	11	0
Total:	-	-	206.28	206.17	22	1

FAR & Tenement Details (Table 4c-1)

Building	No. of Same Bldg	Total Built Up Area (Sq.mt.)	Proposed FAR Area (Sq.mt.) Resi.	Total FAR Area (Sq.mt.)	Total Consumed Additional FAR Area (Sq.mt.)	Tnmt (No.)
A (RENU)	1	206.28	206.28	206.28	206.28	01
Grand Total :	1	206.28	206.28	206.28	206.28	01

Building USE/SUBUSE Details

Building Name	Building Use	Building SubUse	Building Structure
A (RENU)	Residential	Bungalow/ Dwelling / Non Apartment	Non-Highrise

COLOR INDEX

PLOT BOUNDARY	Black
ABUTTING ROAD	Red
PROPOSED CONSTRUCTION	Green
COMMON PLOT	Blue
ROAD WIDENING AREA	Yellow
EXISTING (To be retained)	Orange
EXISTING (To be demolished)	Purple

LTP NAME AND SIGNATURE	STRUCTURAL ENG'S NAME AND SIGNATURE	BUILDER NAME AND SIGNATURE	DIGITAL SIGNATURE
AMRIT KUMAR MAHATO CMC/DFTM/0004/2019			