

Project Title -RENU KUMARI

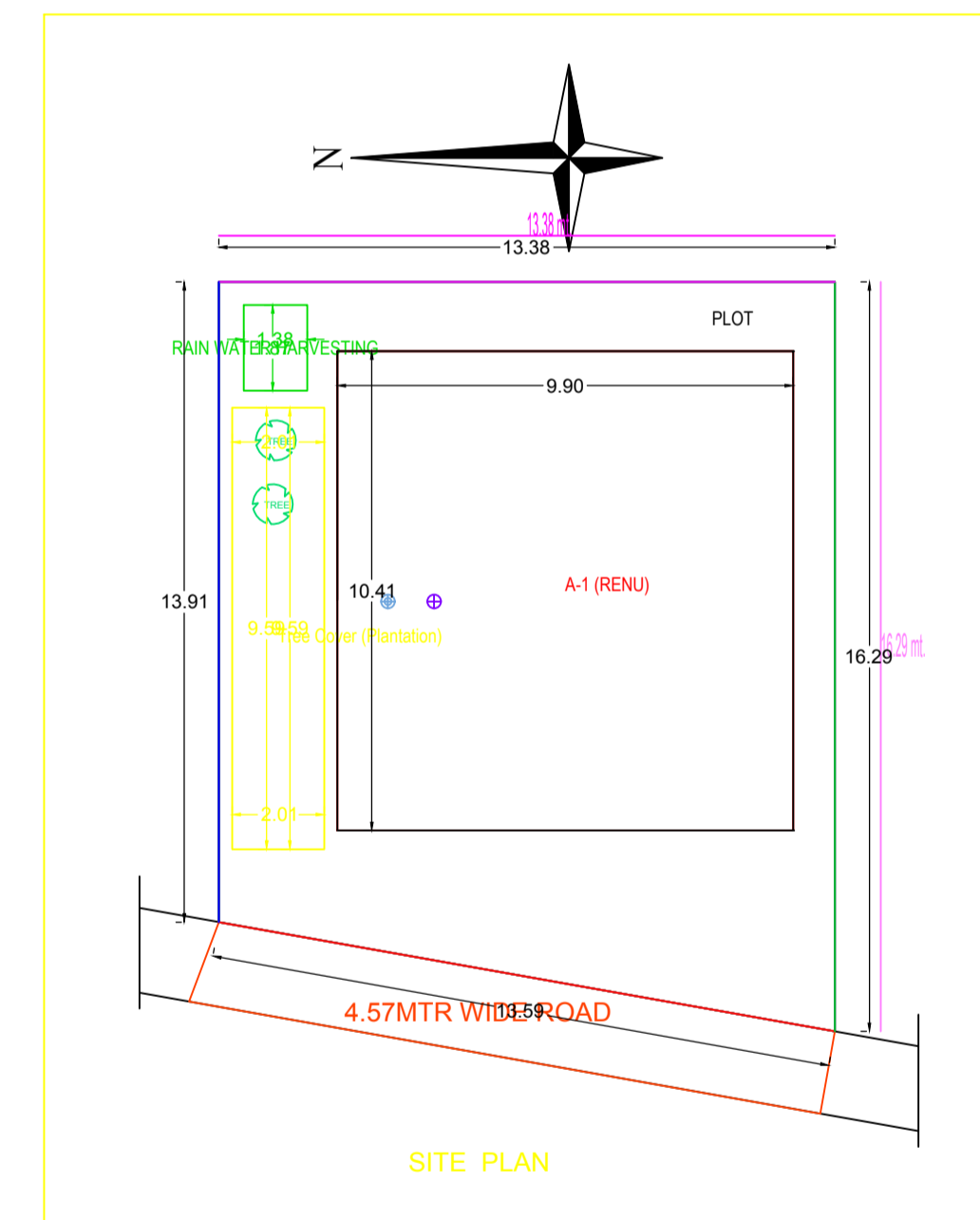
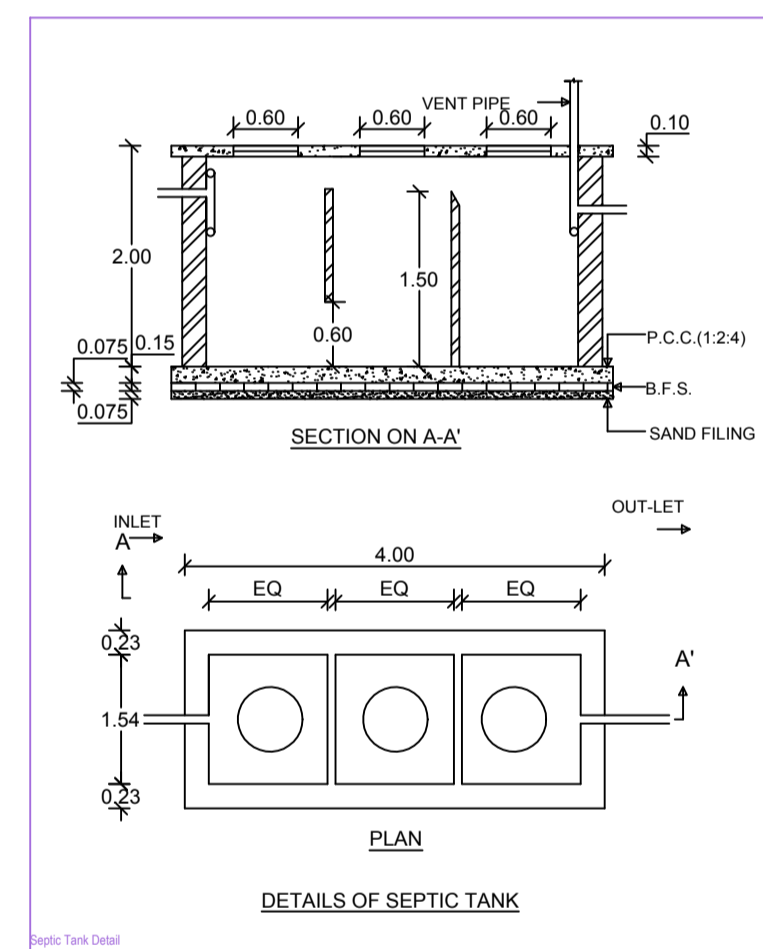
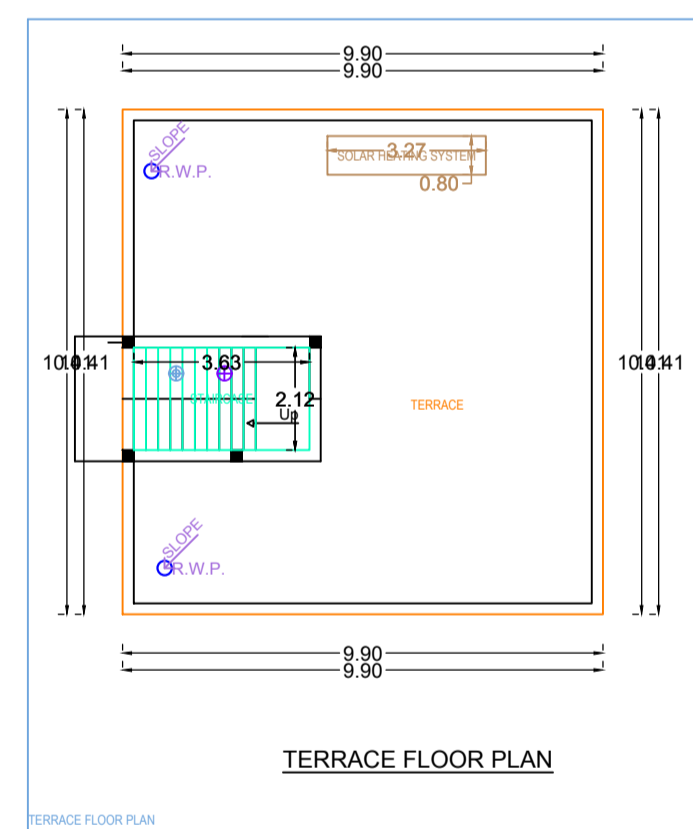
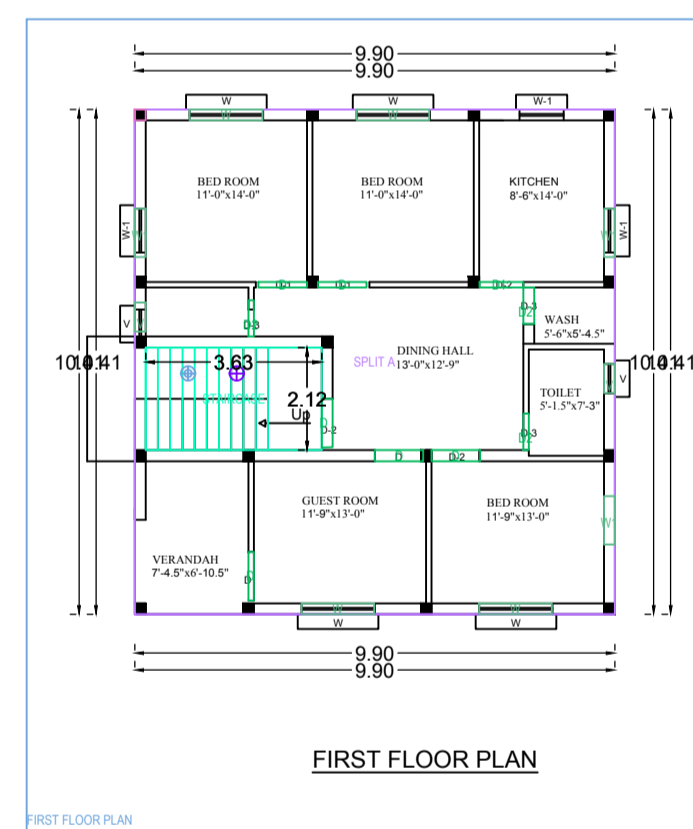
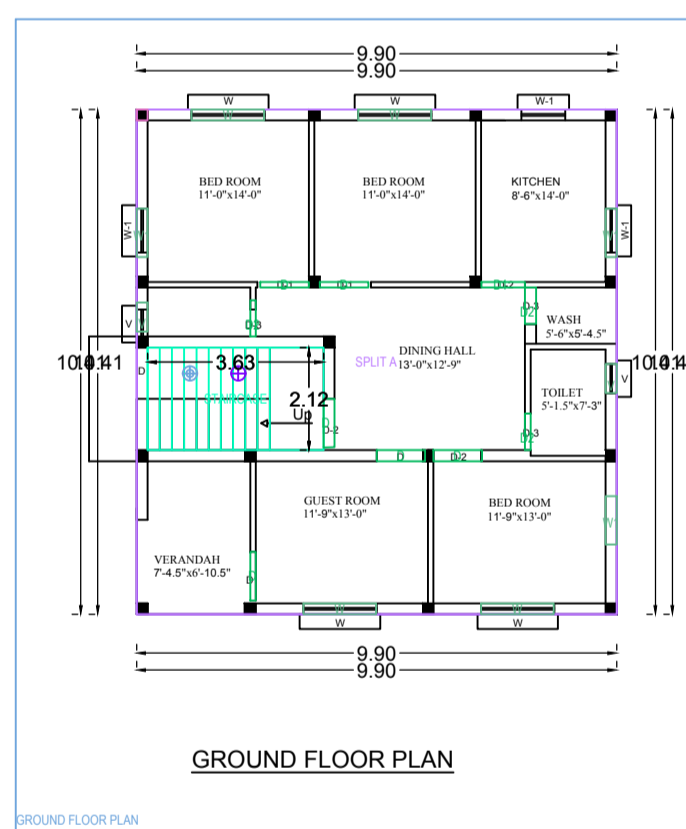
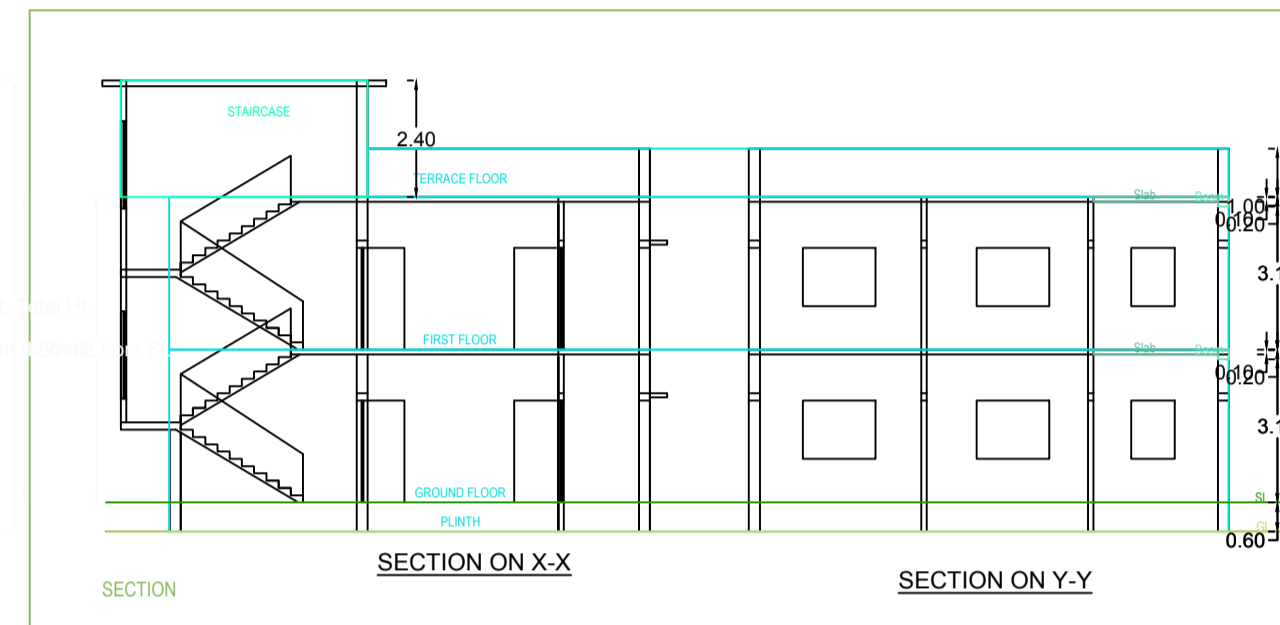
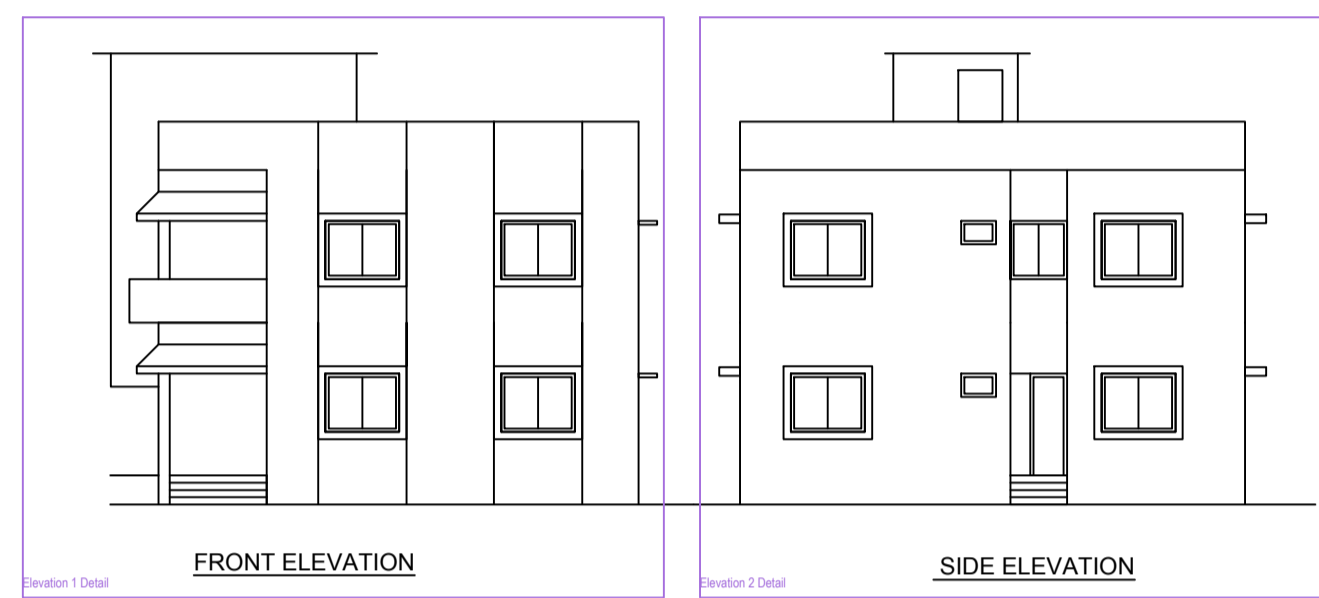
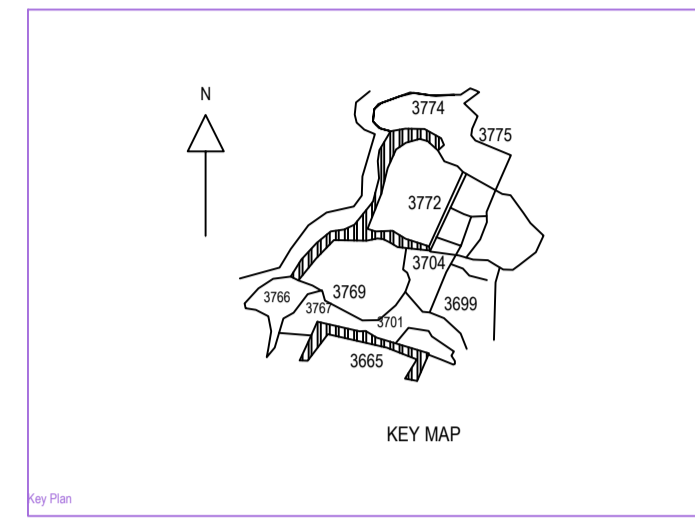
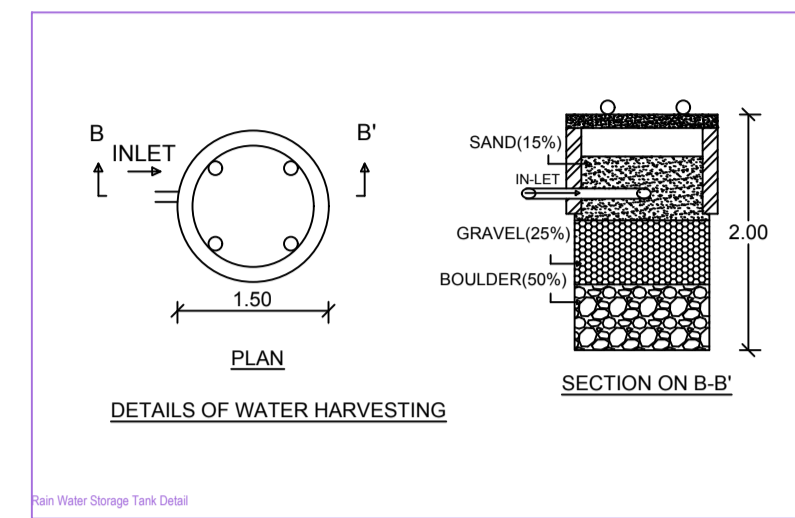
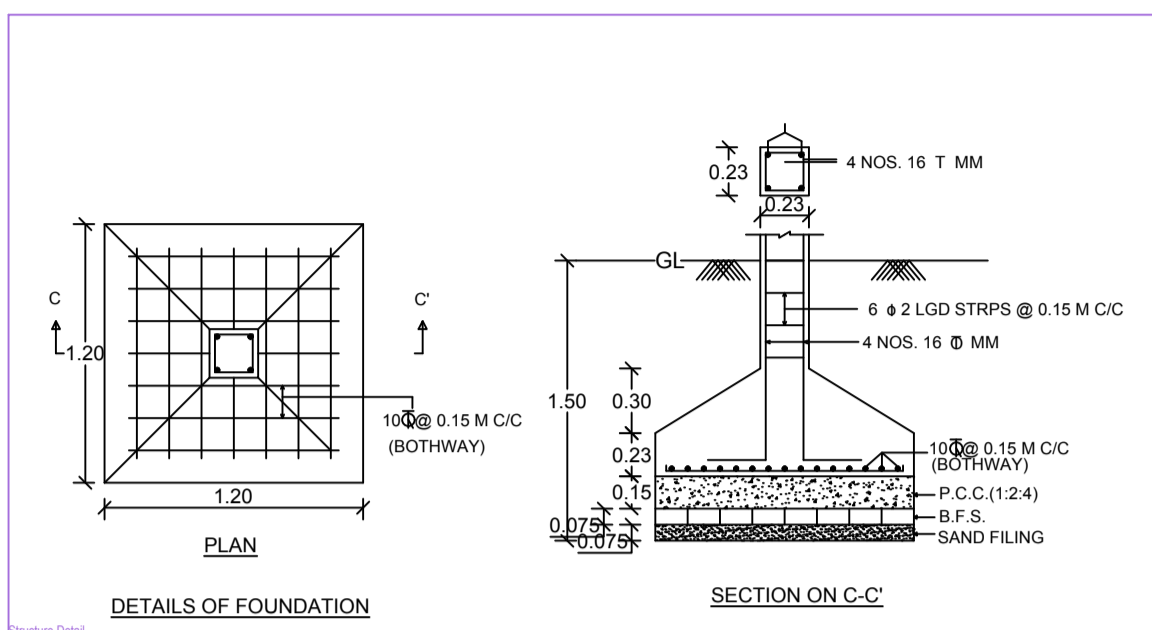

AREA STATEMENT CHAS MUNICIPAL CORPORATION	VERSION NO. 1.0.36
PROJECT DETAIL:	VERSION DATE: 16/03/2020
Plot No.:	Plot Use: Residential
Region: BHARHANI URBAN LOCAL BODIES	Plot Scheme: Bangalore Dwelling / Non Apartment
District: BOKARO	Land Use Zone: NA
Application Type: General Proposal	Abutting Road Width: -
Project Type: Building Permission	Plot No.:
Nature of Development: New	Revenue Survey No/Survey No.:
Location: Old Area	Thana No.:
S/S Location: NA	Ward No.:
Village/Moza Name: -	Khata No.:
Ward No.:	North:
Road/Street: -	South:
	East:
	West:

AREA DETAILS:	AREA	SQ.MT
AREA OF PLOT (Minimum)	(A)	202.03
NET PLOT AREA (Gross Plot Area)	(A-Deductions)	202.03
Deduction from Gross Plot Area		
Deductions for Balance Plot Area (from Gross Plot Area)		
CSP Area		19.23
Total		19.23
Balance Plot Area (Net Plot Area - Recreational/Amenity space)	(A-Deductions)	182.80
Plot Area for Coverage (Net Plot Area)	(A-Deductions)	202.03
Plot Area for FSI (Net Plot Area - Road/Marketing Area)	(A-Deductions)	202.03
COVERAGES CHECK		
Proposed Coverage Area (S17.5%)		103.14
Total Coverage Area (S17.5%)		103.14
FAR CHECK		
Proposed Area of FAR		206.28
Total Area of FAR		206.28
BUILT UP AREA CHECK		
Total Proposed Building Area		206.28
APPOINT ENGINEER / SUPERVISOR (Regd)		OWNER
DEVELOPMENT AUTHORITY		LOCAL BODY

COLOR INDEX	
LOT BOUNDARY	Black
ABUTTING ROAD	Red
PROPOSED WORK (COVERAGE AREA)	Green
EXISTING (To be retained)	Yellow
EXISTING (To be demolished)	Blue

MARGIN DETAIL:					
Building / Wing	Road Name	Front Margin	Rear Margin	Side1 Margin	Side2 Margin
A-1 (RENU)	4.57MTR WIDE ROAD	2.41	1.50	2.57	0.90

FAR & Tenement Details (Table 4c-1)					
Building	No. of Same Bldg	Total Built Up Area (Sq.mt)	Proposed FAR Area (Sq.mt)	Total FAR Area (Sq.mt)	Tenmt (No.)
A-RENU	1	206.28	206.28	206.28	01
Grand Total:	1	206.28	206.28	206.28	01

Building A (RENU)					
Floor Name	Total Built Up Area (Sq.mt)	Proposed FAR Area (Sq.mt)	Total FAR Area (Sq.mt)	Tenmt (No.)	
Ground Floor	103.14	103.14	103.14	01	
First Floor	103.14	103.14	103.14	00	
Terrace Floor	0.00	0.00	0.00	01	
Total	206.28	206.28	206.28	01	
Total Number of Same Buildings	1				
Total	206.28	206.28	206.28	01	

SCHEDULE OF JOINERY:				
BUILDING NAME	NAME	LENGTH	HEIGHT	NOS
A (RENU)	D1	0.75	2.10	06
A (RENU)	D1	0.90	2.10	02
A (RENU)	D	1.00	2.10	12
Total	-	-	-	20

SCHEDULE OF JOINERY:				
BUILDING NAME	NAME	LENGTH	HEIGHT	NOS
A (RENU)	V	0.60	1.00	04
A (RENU)	W1	1.00	1.20	08
A (RENU)	W	1.50	1.20	08
Total	-	-	-	18

UnitBUA Table for Building A (RENU)						
FLOOR	Name	UnitBUA Type	UnitBUA Area	Carpet Area	No. of Rooms	No. of Tenement
GROUND FLOOR PLAN	SPLIT A	FLAT	206.28	206.17	11	1
Total	-	-	206.28	206.17	22	1