

Proposal Basic Information

Proposal File No.	CMC/BP/0115/W06/2023
Owner Name	ANITA DEVI
Khata No	13
Plot No	873
Village Name	Bhawanipur
Use	Residential
SubUse	Bungalow/ Dwelling / Non Apartment

AREA STATEMENT CHAS MUNICIPAL CORPORATION

Version No.	1.0.66
Version Date	16/10/2020

AREA DETAILS:

AREA OF PLOT (Minimum)	(A)	SQ.MT.	323.45
NET AREA OF PLOT(Gross Plot Area)	(A-Deductions)		323.45
Deduction for Balance Plot Area(from Gross Plot Area)			
Common Plot			62.34
Total			62.34
BALANCE AREA OF PLOT(Net Plot Area - Recreational/Amenity space)	(A-Deductions)		261.11
PLOT AREA FOR COVERAGE(Net Plot Area)	(A-Deductions)		323.45
Plot Area for FAR (Net Plot Area + Road/Widening Area)	(A-Deductions)		323.45
COVERAGE CHECK			
Permissible Coverage area (60.00 %)			194.07
Proposed Coverage Area (28.73 %)			92.93
Total Prop. Coverage Area (28.73 %)			92.93
Balance coverage area (31.27 %)			101.14
FAR CHECK			
Perm. FAR Area (1.500)			485.18
Total Perm. FAR area			485.18
Residential FAR			278.80
Proposed FAR Area			278.80
Total Proposed FAR Area			278.80
Consumed FAR (Factor)			0.86
Balance FAR Area			206.38
BUILT UP AREA CHECK			
Total Proposed BuiltUp Area			278.79
ARCHITECT (Regd)		Sumita Kumari	
ENGINEER (Regd)			
SUPERVISOR (Regd)			
OWNER (Regd)		ANITA DEVI	
DEVELOPMENT AUTHORITY		LOCAL BODY	

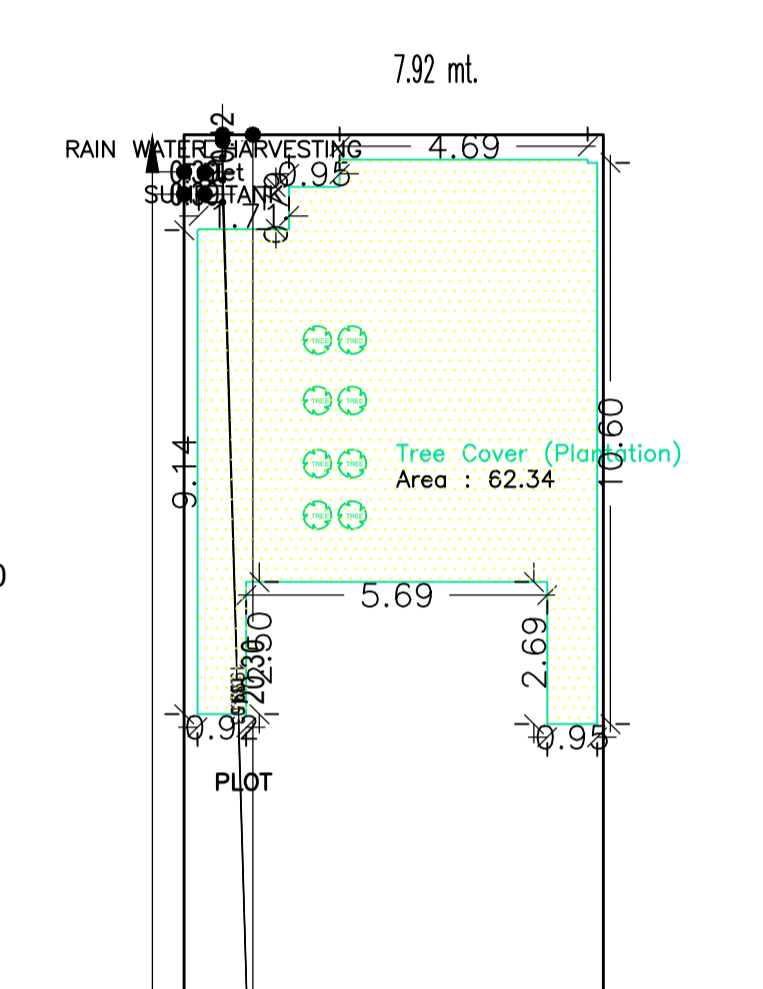
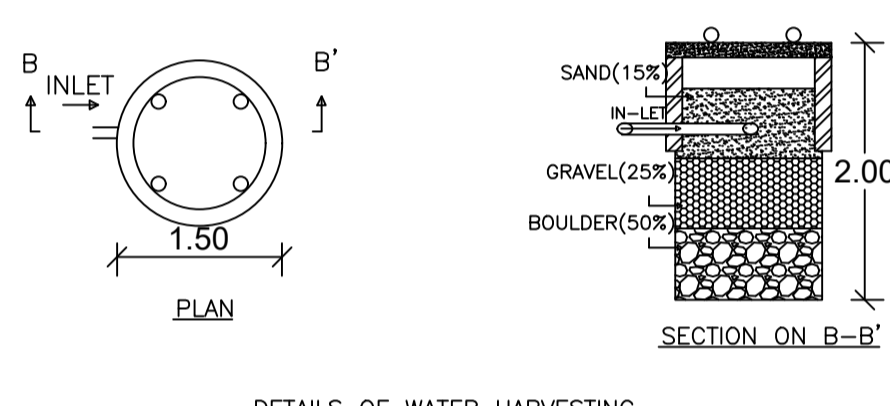
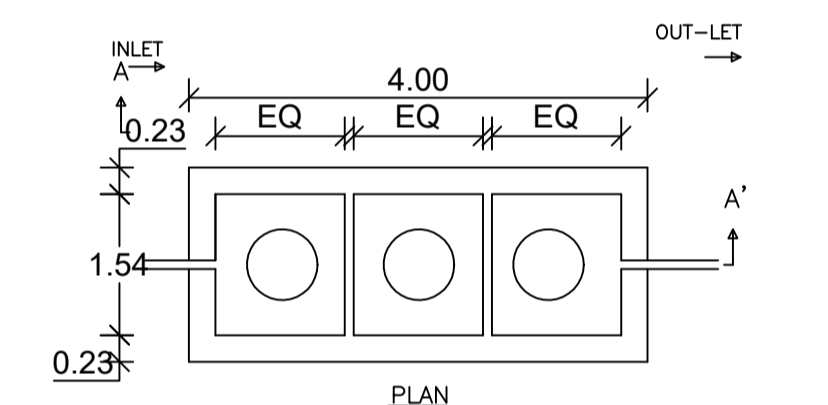
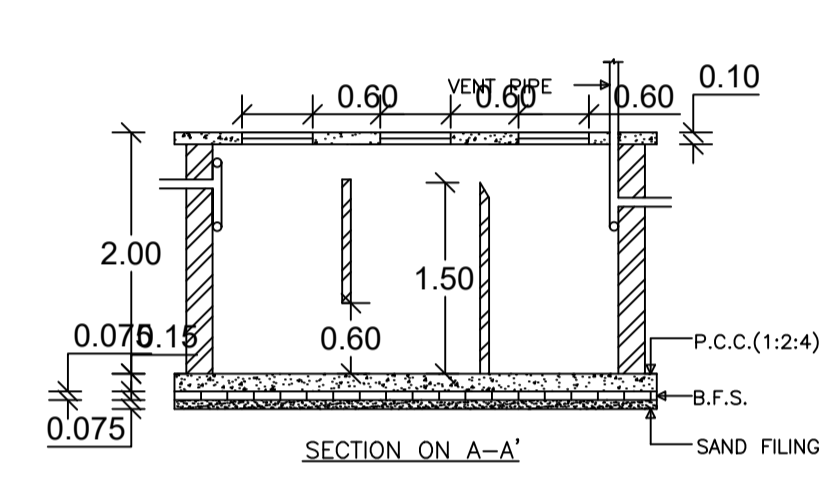
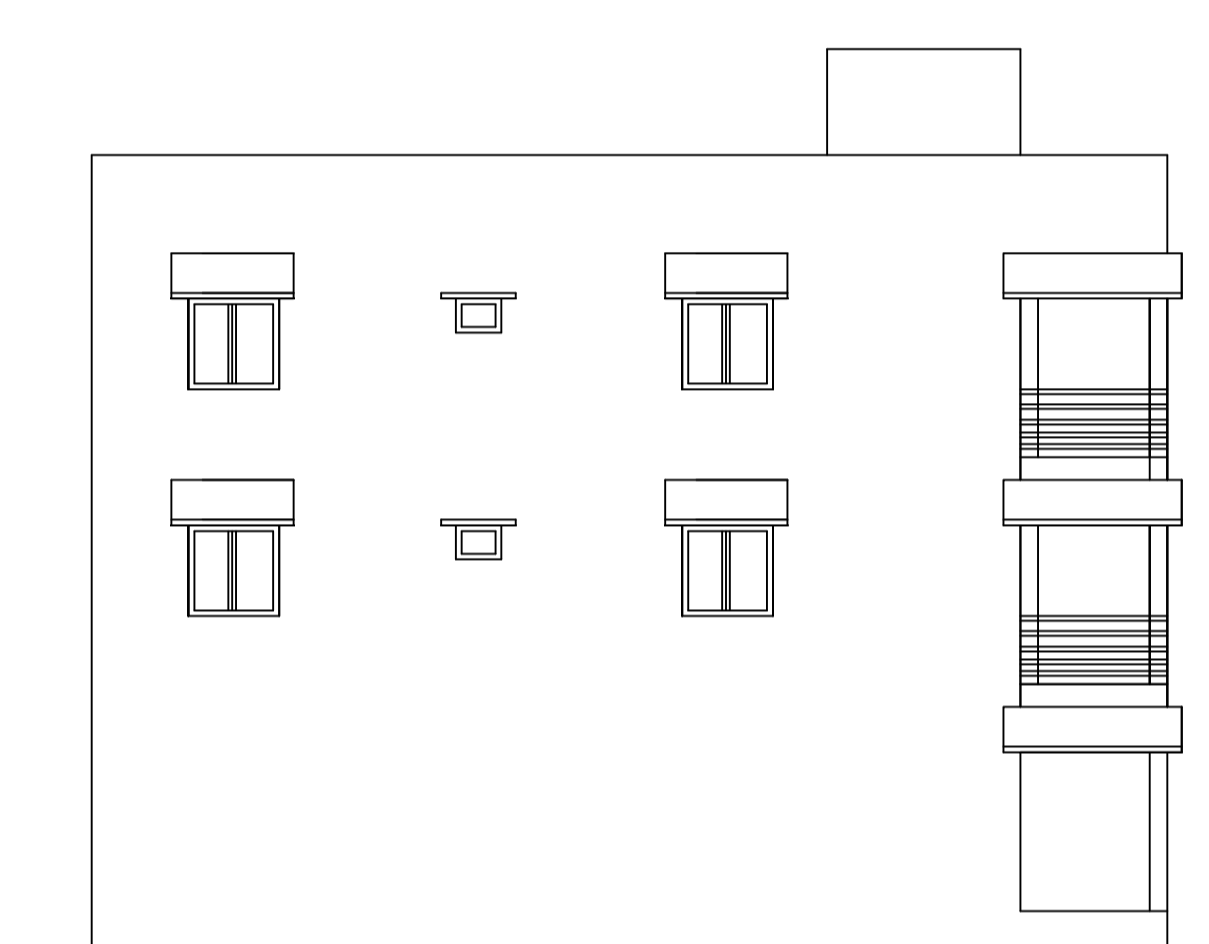
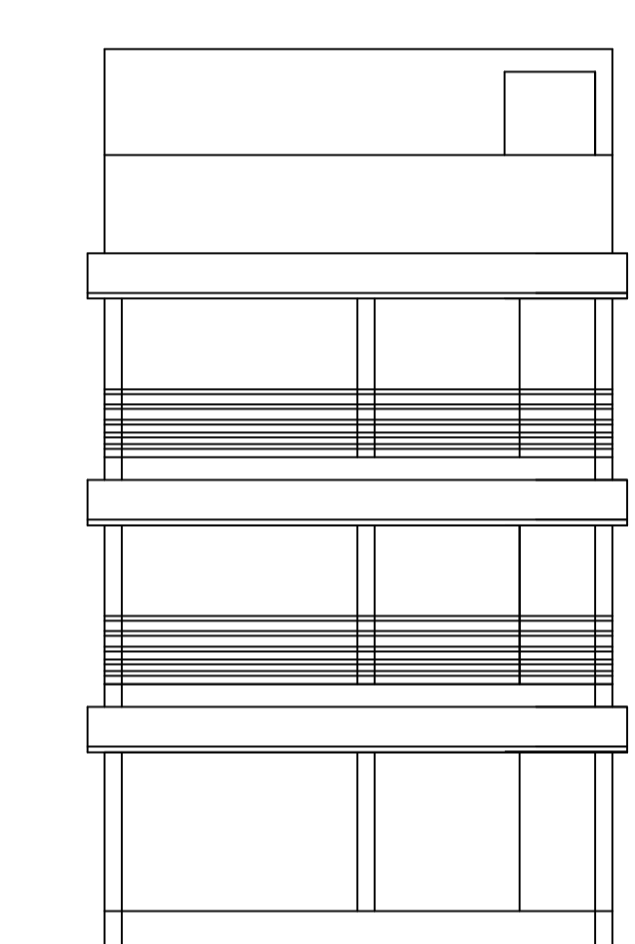

FRONT ELEVATION

RIGHT SIDE ELEVATION

DETAILS OF SEPTIC TANK

DETAILS OF WATER HARVESTING

SITE PLAN

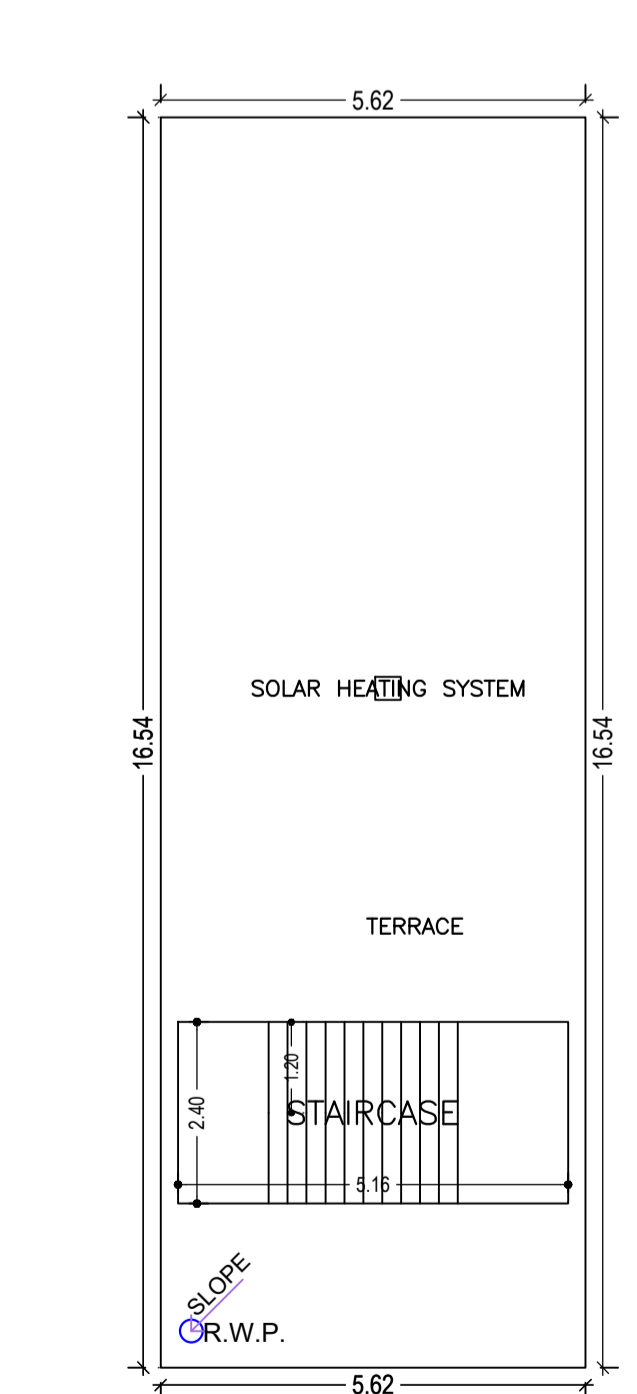
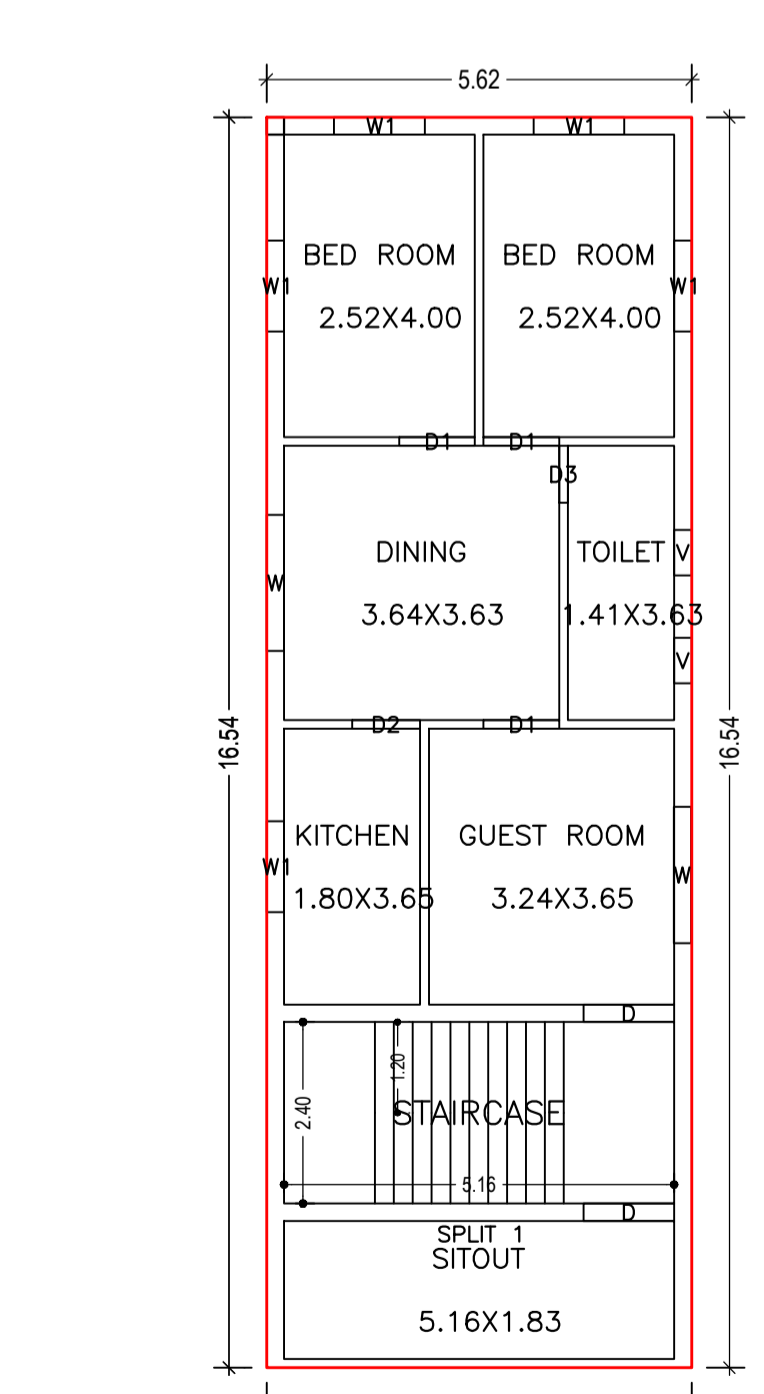
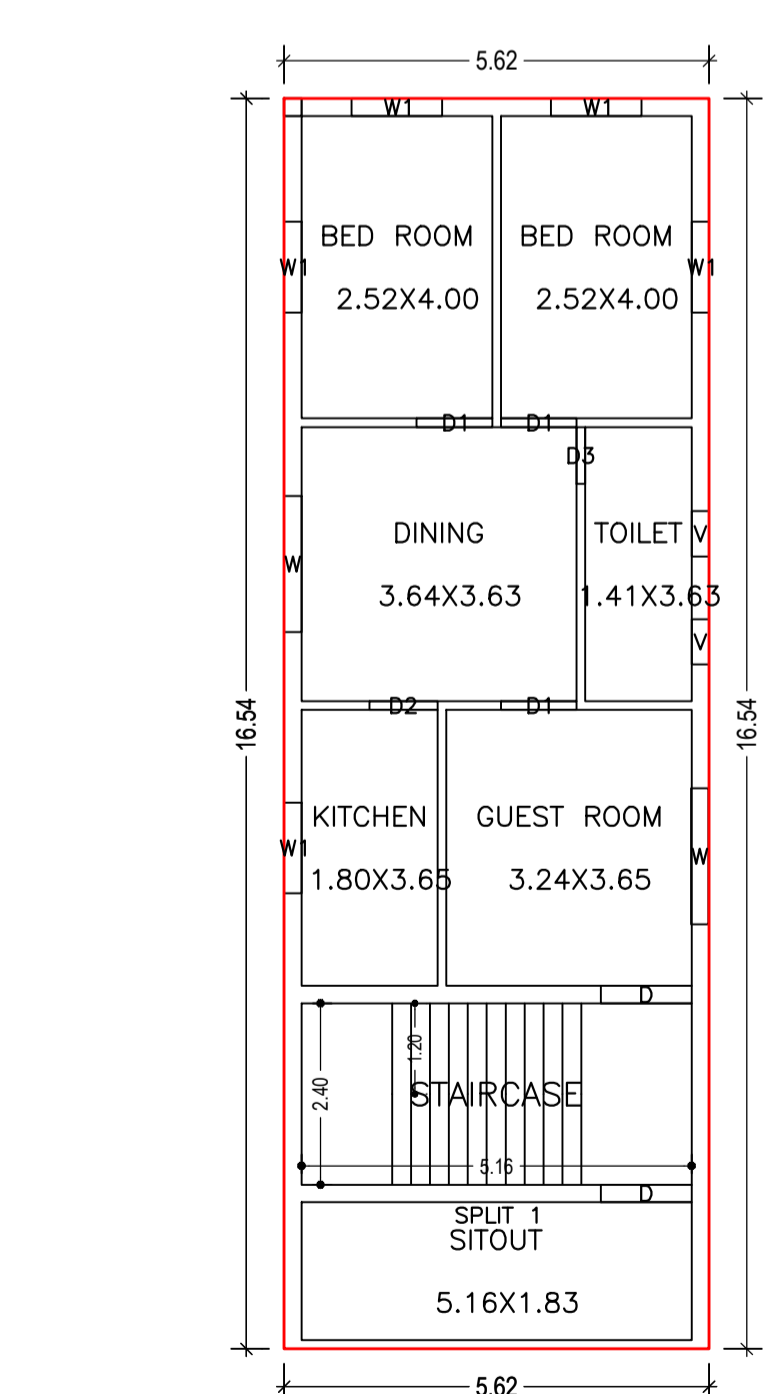
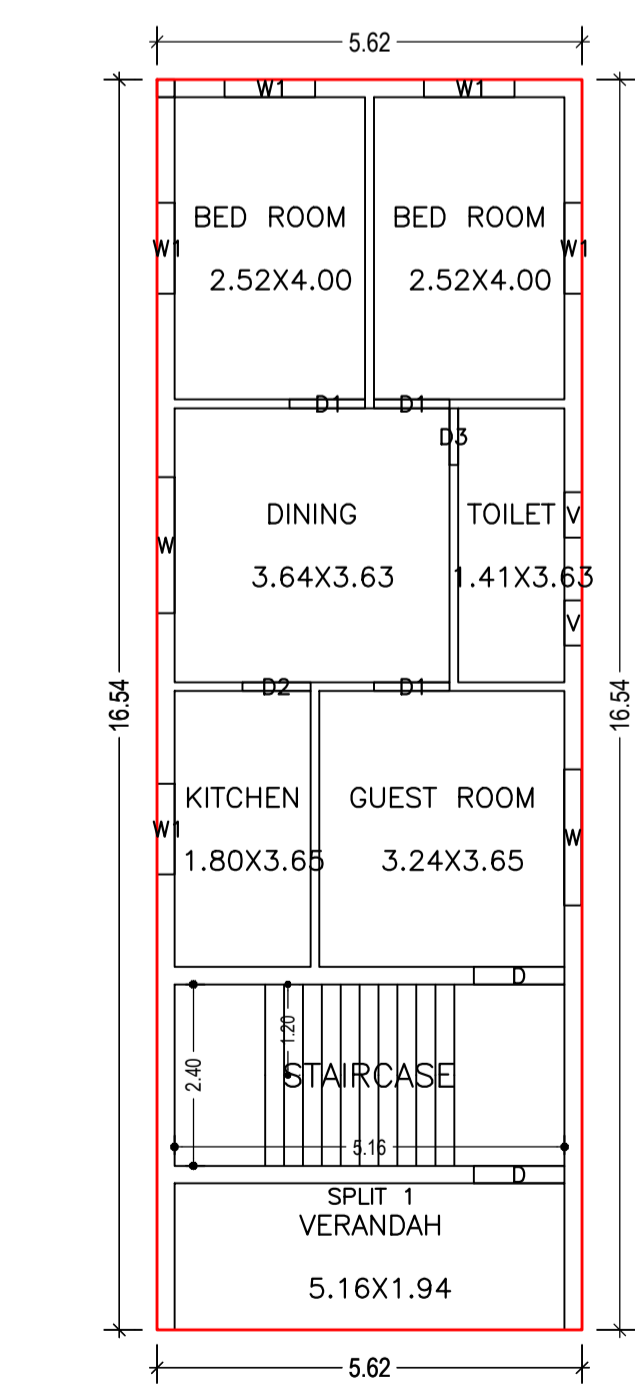

GROUND FLOOR PLAN (Proposed) (SCALE 1:100)

FIRST FLOOR PLAN (Proposed) (SCALE 1:100)

SECOND FLOOR PLAN (Proposed) (SCALE 1:100)

TERRACE FLOOR PLAN (SCALE 1:100)

Building USE/SUBUSE Details

Building Name	Building Use	Building SubUse	Building Structure
A (ANITA DEVI)	Residential	Bungalow/ Dwelling / Non Apartment	Non-Highrise

SCHEDULE OF DOOR:

BUILDING NAME	NAME	LENGTH	HEIGHT	NOS
A (ANITA DEVI)	D3	0.75	2.10	03
A (ANITA DEVI)	D2	0.80	2.10	03
A (ANITA DEVI)	D1	1.50	2.10	09
A (ANITA DEVI)	D	1.20	2.10	06

SCHEDULE OF WINDOW/VENTILATION:

BUILDING NAME	NAME	LENGTH	HEIGHT	NOS
A (ANITA DEVI)	V	0.60	1.20	06
A (ANITA DEVI)	W1	1.20	1.20	15
A (ANITA DEVI)	W	1.80	1.20	06

COLOR INDEX

PLOT BOUNDARY	Black
ABUTTING ROAD	Green
PROPOSED CONSTRUCTION	Red
COMMON PLOT	Yellow
ROAD WIDENING AREA	Blue
EXISTING (To be retained)	Grey
EXISTING (To be demolished)	White

LTP NAME AND SIGNATURE

Sumita Kumari
CMC/ARC/0006/2021

STRUCTURAL ENG'S NAME AND SIGNATURE

BUILDER NAME AND SIGNATURE

DIGITAL SIGNATURE

Buildingwise Floor FAR Details

Floor Name	Building Name A (ANITA DEVI)		Total	
	Proposed Built Up Area (Sq.mt.)	Proposed FAR Area (Sq.mt.)	Total Proposed Built Up Area (Sq.mt.)	Total FAR Area (Sq.mt.)
Ground Floor	92.93	92.93	92.93	92.93
First Floor	92.93	92.93	92.93	92.93
Second Floor	92.93	92.93	92.93	92.93
Terrace Floor	0.00	0.00	0.00	0.00
Total :	278.79	278.79	278.79	278.79

Building :A (ANITA DEVI)

Floor Name	Total Built Up Area (Sq.mt.)	Proposed FAR Area (Sq.mt.)	Total FAR Area (Sq.mt.)	Total Consumed Additional FAR Area (Sq.mt.)	Tnmt (No.)
Ground Floor	92.93	92.93	92.93	92.93	01
First Floor	92.93	92.93	92.93	92.93	00
Second Floor	92.93	92.93	92.93	92.93	00
Terrace Floor	0.00	0.00	0.00	0.00	00
Total :	278.79	278.79	278.79	278.79	01

UnitBUA Table for Building :A (ANITA DEVI)

FLOOR	Name	UnitBUA Type	UnitBUA Area	Carpel Area	No. of Rooms	No. of Tenement
FIRST FLOOR PLAN	SPLIT 1	FLAT	0.00	0.00	7	0
SECOND FLOOR PLAN	SPLIT 1	FLAT	0.00	0.00	7	0
GROUND FLOOR PLAN	SPLIT 1	FLAT	278.80	278.64	7	1
Total :	-	-	278.80	278.64	21	1

FAR & Tenement Details (Table 4c-1)

Building	No. of Same Bldg	Total Built Up Area (Sq.mt.)	Proposed FAR Area (Sq.mt.)	Total FAR Area (Sq.mt.)	Total Consumed Additional FAR Area (Sq.mt.)	Tnmt (No.)
A (ANITA DEVI)	1	278.79	278.79	278.79	278.79	01
Grand Total :	1	278.79	278.79	278.79	278.79	01