

Proposal Basic Information	
Proposal File No.	CMC/BP/0170/W32/2023
Owner Name	SANJEET KUMAR
Khata No	730
Plot No	7514
Village Name	Chas
Use	Residential
SubUse	Bungalow/ Dwelling / Non Apartment

AREA STATEMENT CHAS MUNICIPAL CORPORATION		VERSION NO. : 1.0.66
PROJECT DETAIL:		VERSION DATE: 16/10/2020
Region: JHARKHAND URBAN LOCAL BODIES	Plot Use: Residential	
District: BOKARO	Plot SubUse: Bungalow/ Dwelling / Non Apartment	
Authority: CHAS MUNICIPAL CORPORATION	PlotNearbyReligiousStructure: NA	
Inward No: CMC/BP/0170/W32/2023	PlotSubPlot No: 7514	
Application Type: General Proposal	North: Plot No. - SHASHIKANT GUPTA	
Project Type: Building Permission	South: Plot No. - LEELA DEVI	
Nature of Development: New	East: Road Width - 3.05	
Location of Development Area: Old Area	West: Plot No. - PRIYANKA KUMARI	
AREA OF PLOT (Minimum)	(A)	SQ.MT. 243.16
Deduction for NetPlot Area		
Road Widening Area		8.05
Total		8.05
NET AREA OF PLOT(Gross Plot Area - Deduction from Gross Plot area)	(A-Deductions)	235.11
Deduction for Balance Plot Area(from Gross Plot Area)		
Road Widening Area		8.05
Common Plot		37.33
Total		45.38
BALANCE AREA OF PLOT(Net Plot Area - Recreational/Amenity space)	(A-Deductions)	197.78
PLOT AREA FOR COVERAGE(Net Plot Area)	(A-Deductions)	235.11
Plot Area for FAR (Net Plot Area + RoadWidening Area)	(A-Deductions)	235.11
COVERAGE CHECK		
Permissible Coverage area ( 60.00 % )		141.07
Proposed Coverage Area ( 59.35 % )		139.55
Total Prop. Coverage Area ( 59.35 % )		139.55
Balance coverage area ( 0.65 % )		1.52
FAR CHECK		
Perm. FAR Area ( 1.200 )		282.13
Total Perm. FAR area		282.13
Residential FAR		226.42
Proposed FAR Area		226.42
Total Proposed FAR Area		226.42
Consumed FAR (Factor)		0.96
Balance FAR Area		55.71
BUILT UP AREA CHECK		
Total Proposed BuiltUp Area		279.11
ARCHITECT (Regd)	Manish Agarwal	
ENGINEER (Regd)		
SUPERVISOR (Regd)		
OWNER (Regd)	SANJEET KUMAR	
DEVELOPMENT AUTHORITY	LOCAL BODY	

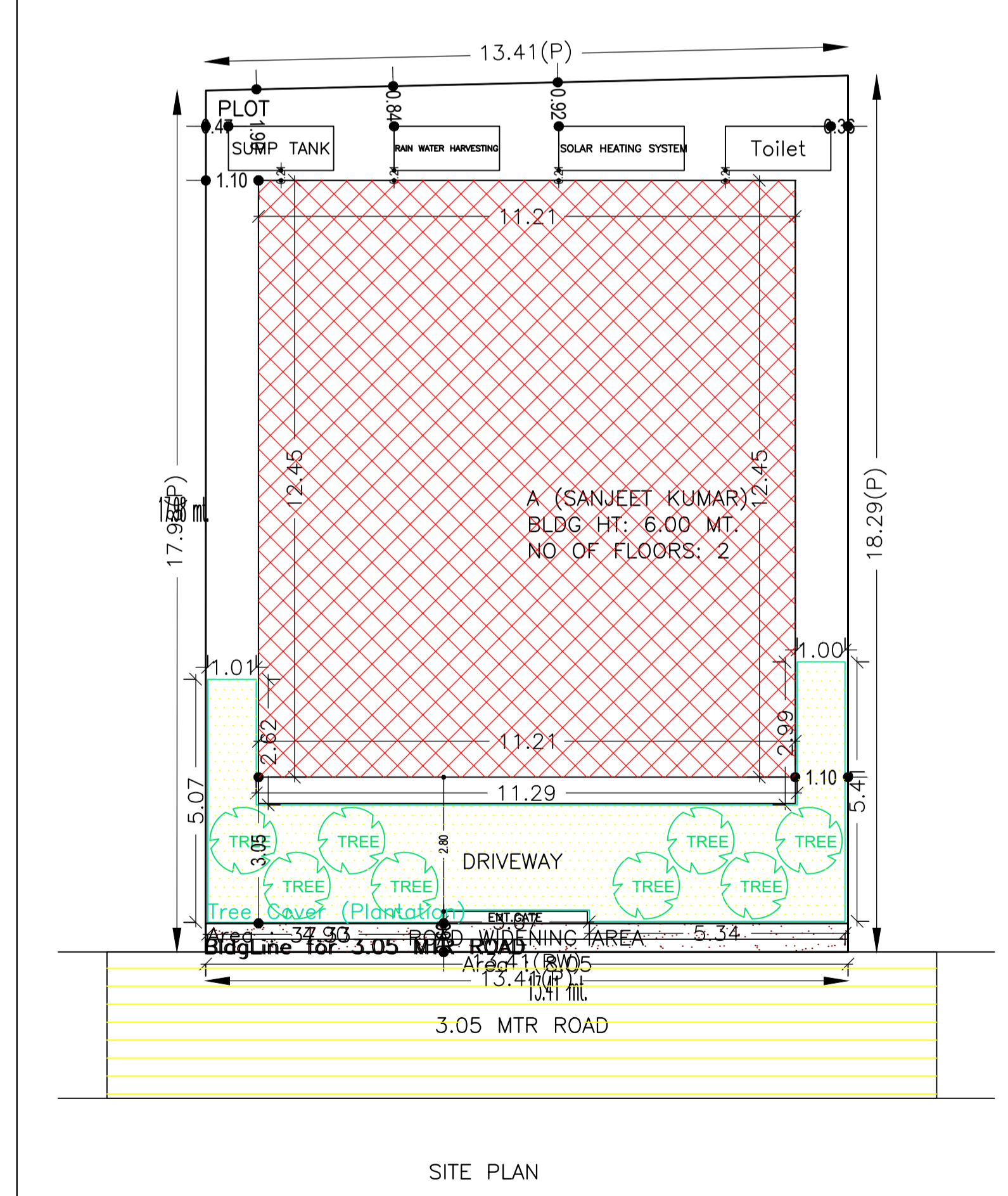
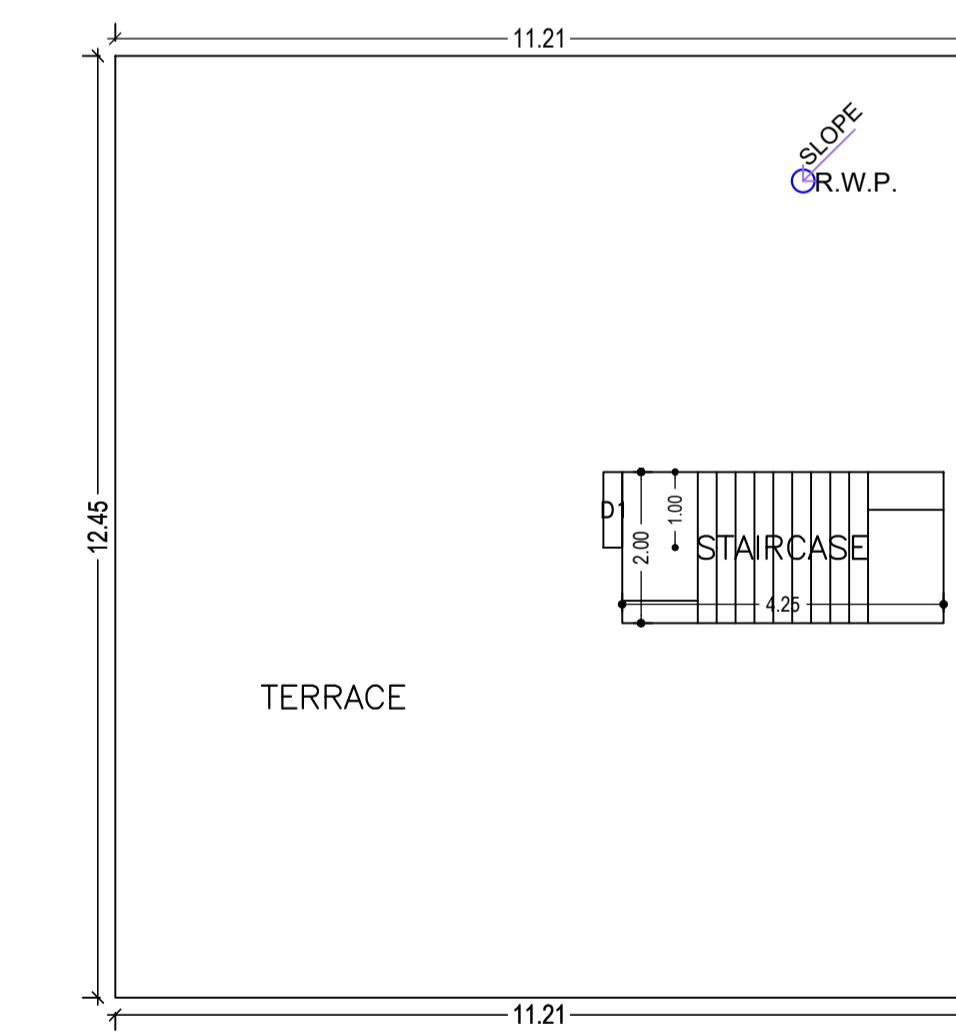
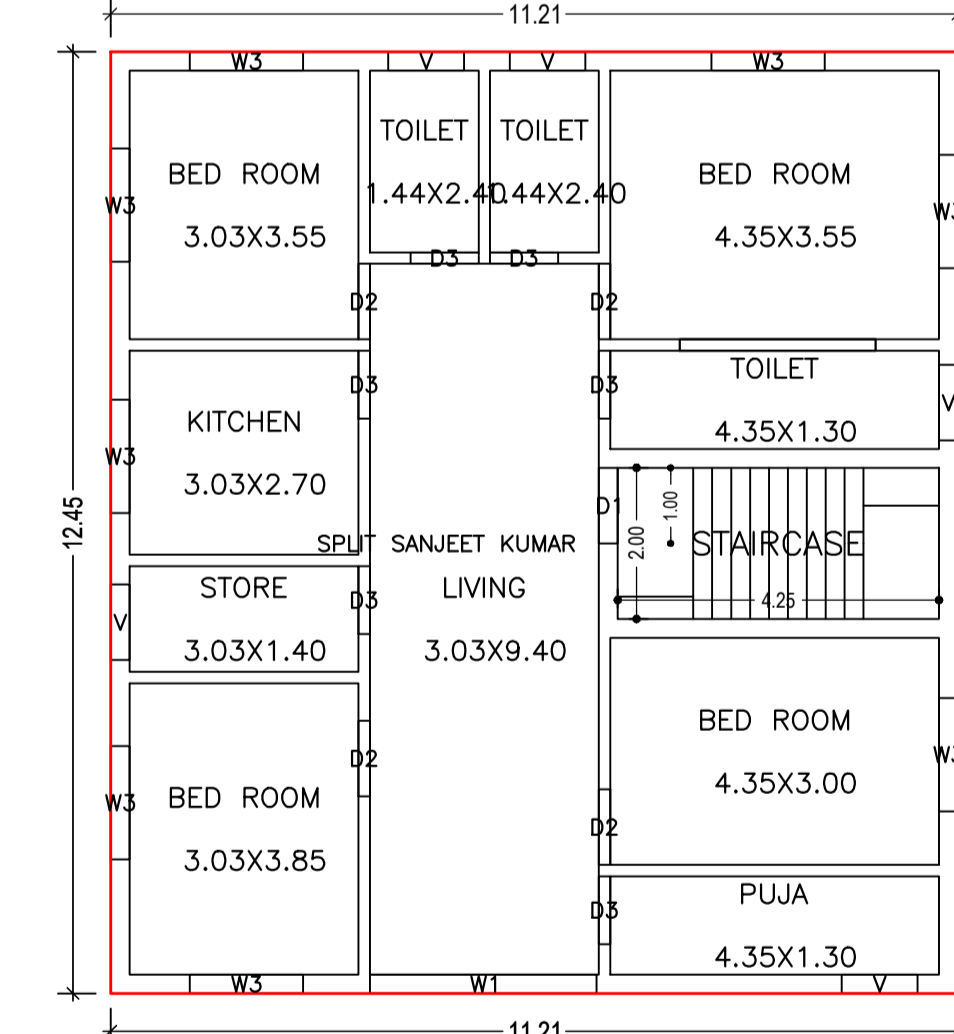
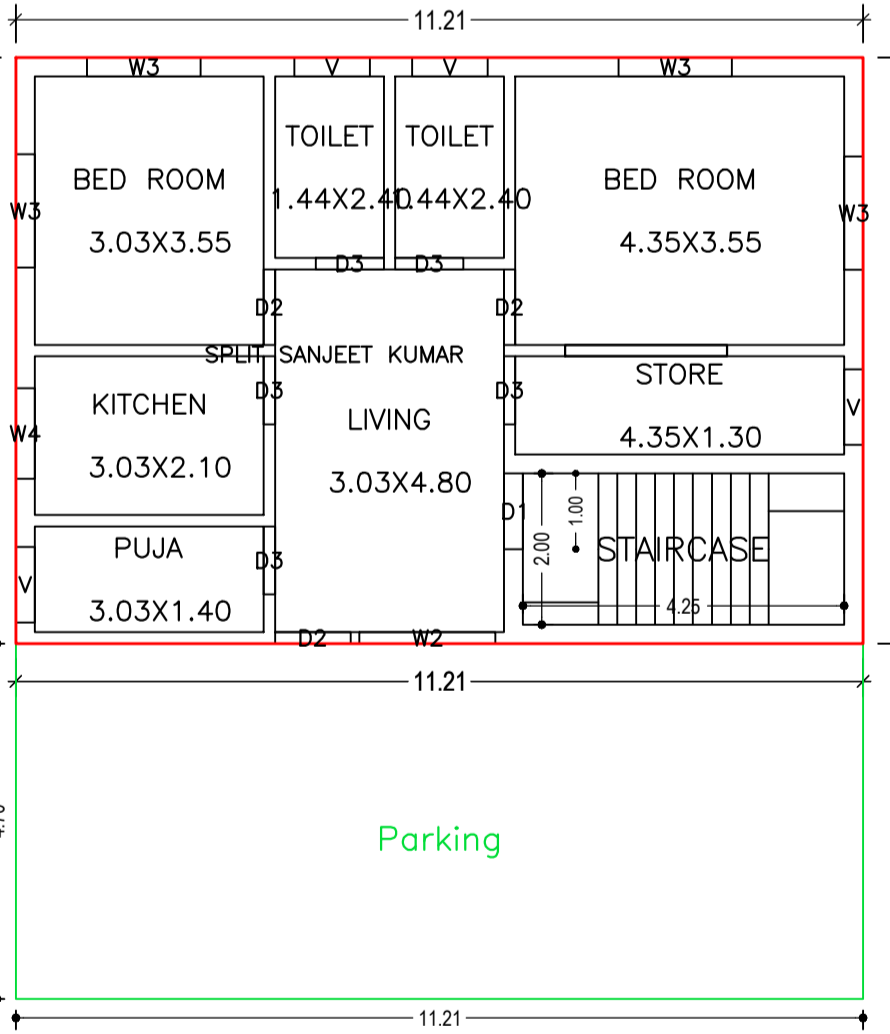
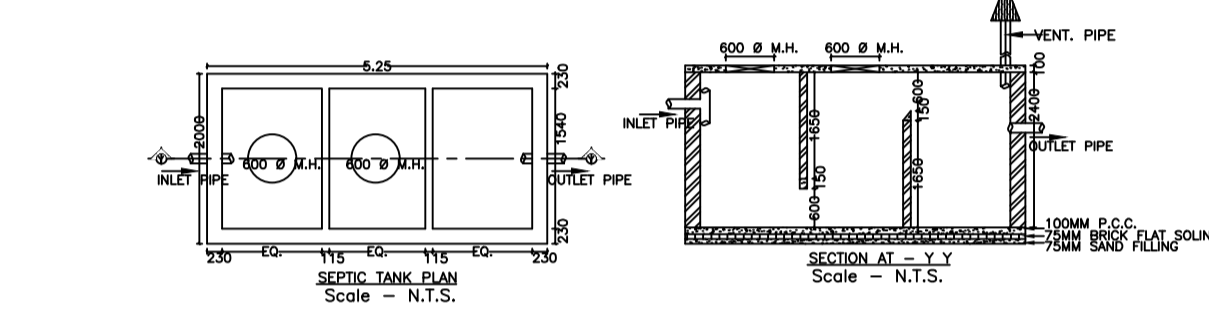
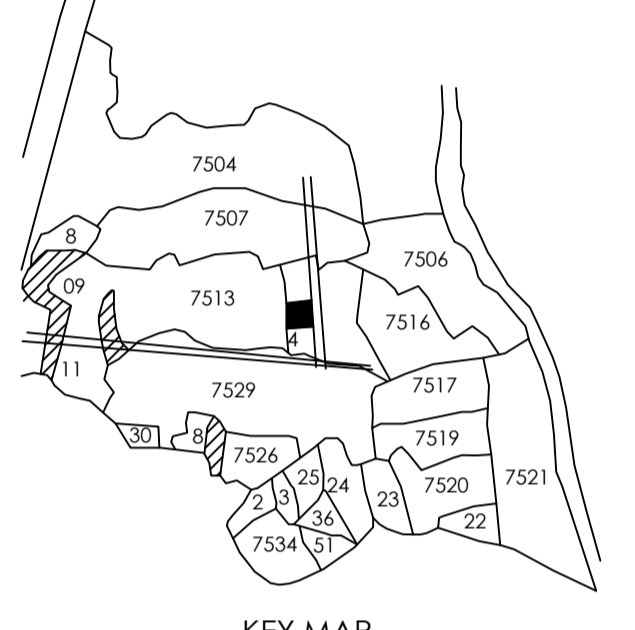
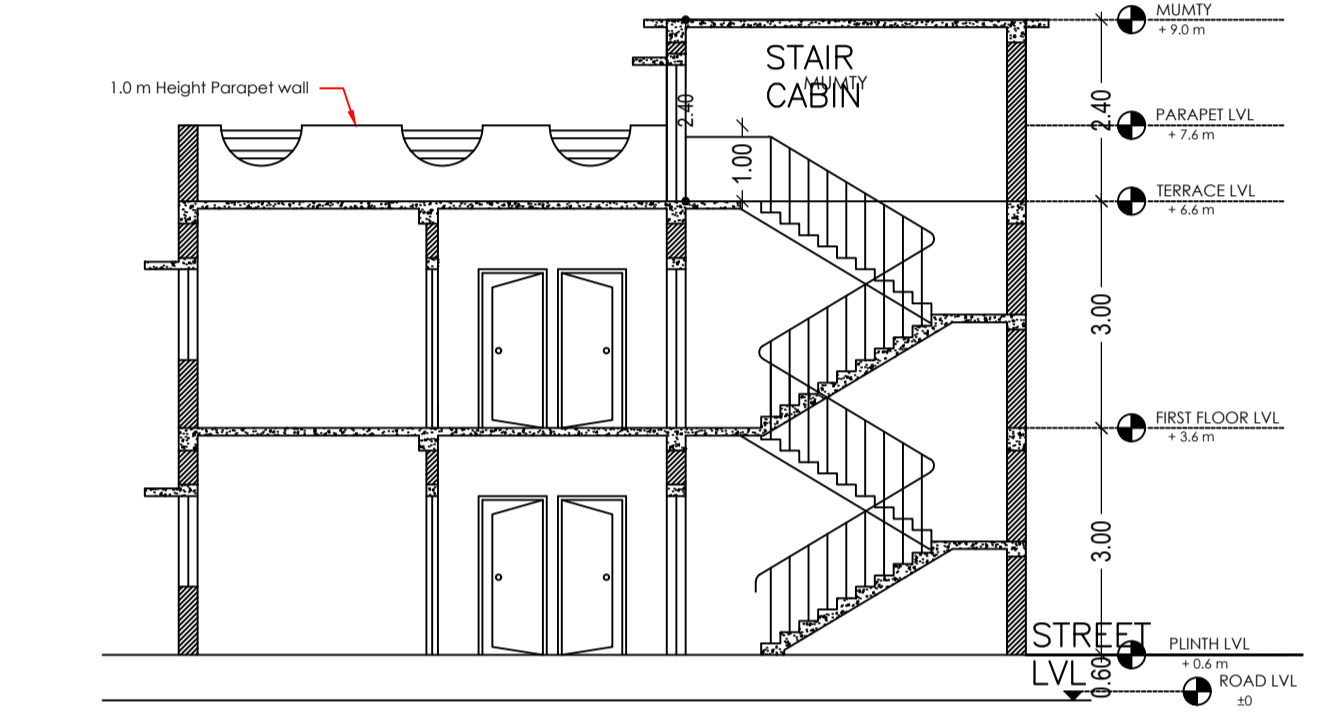
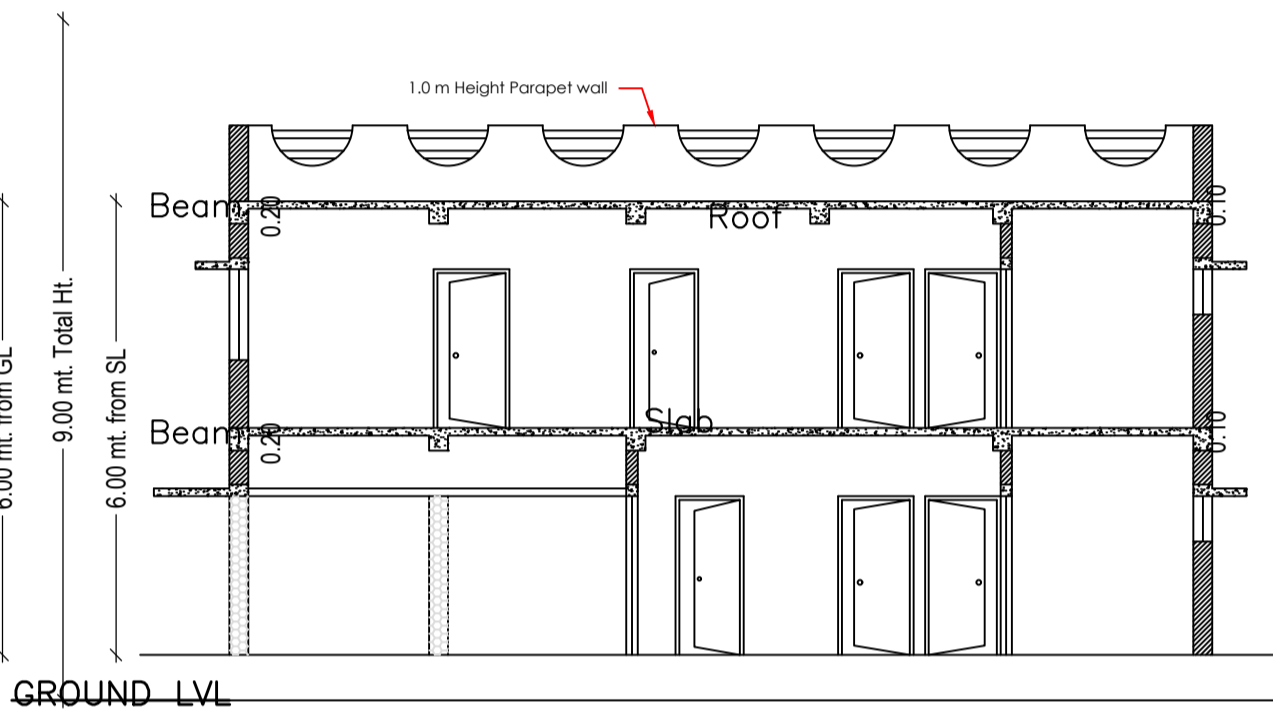
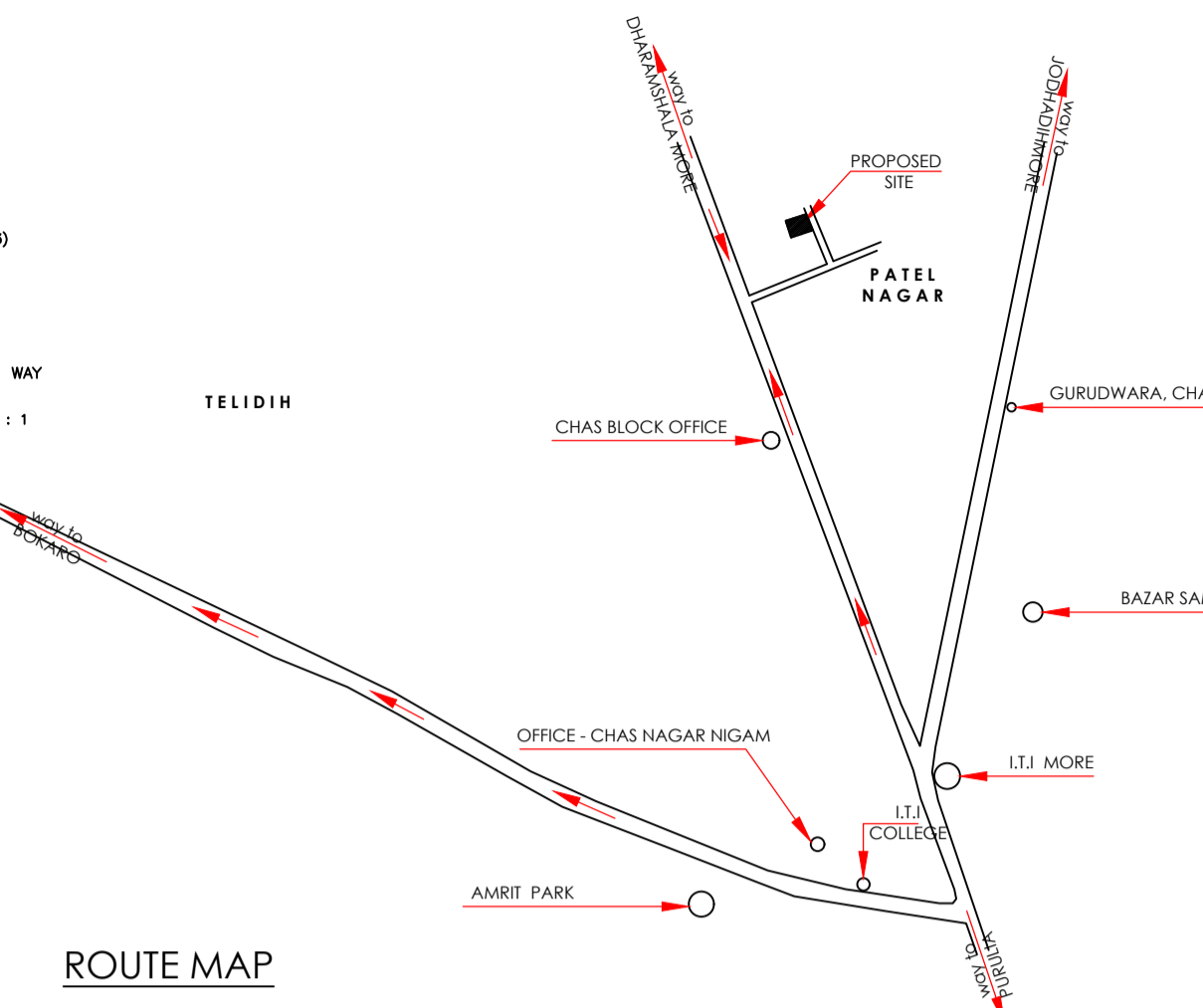
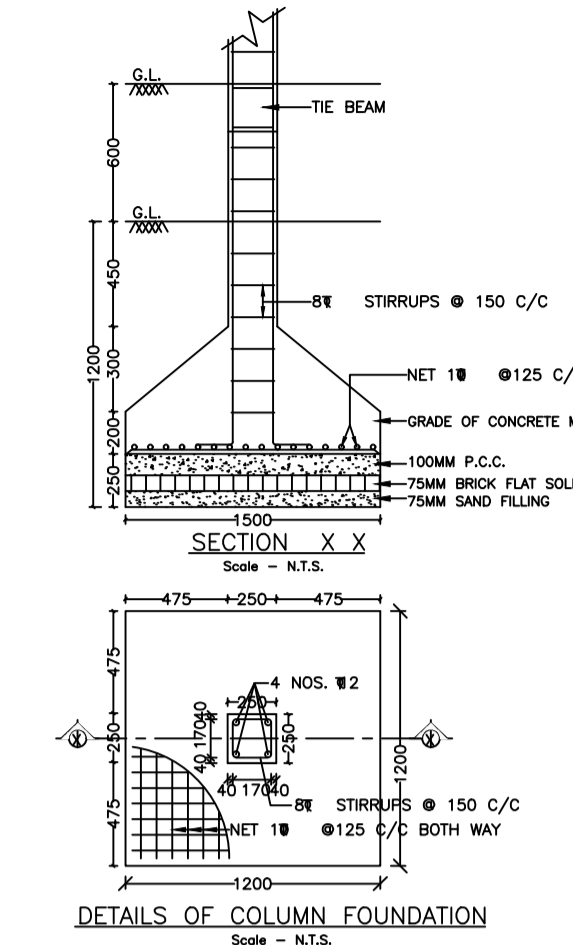
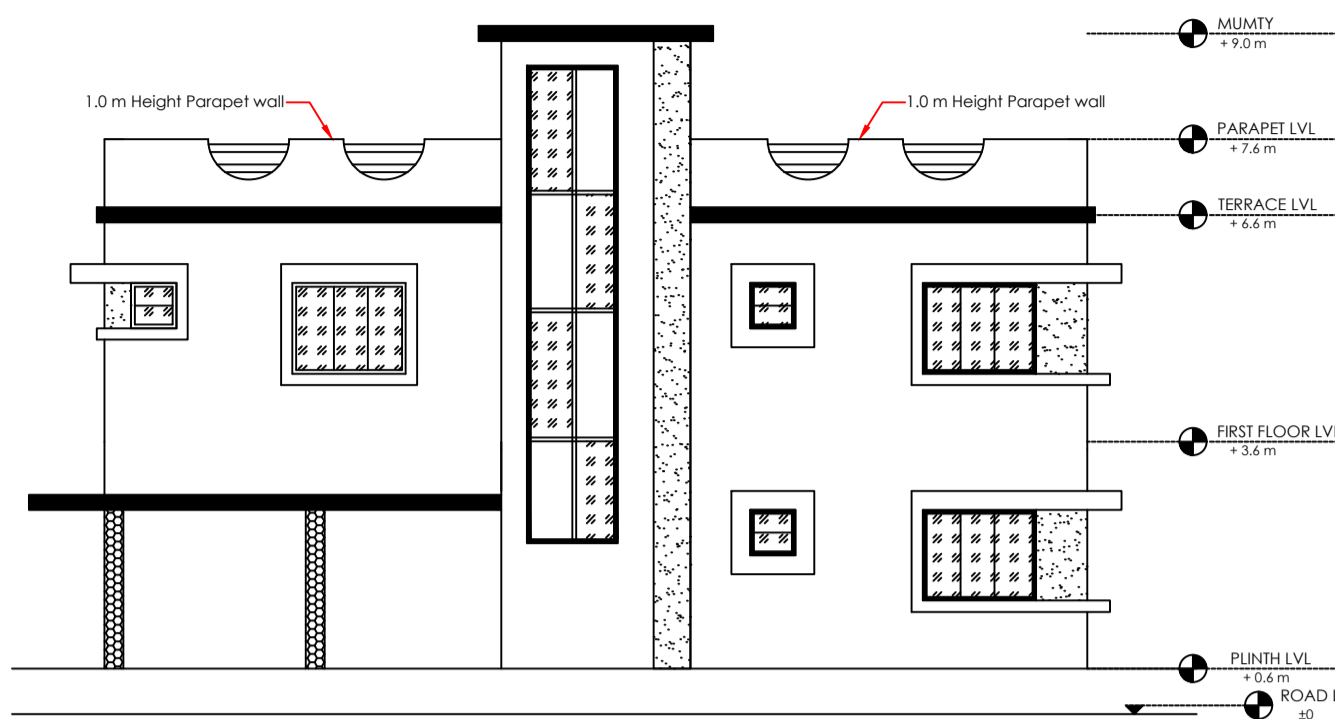
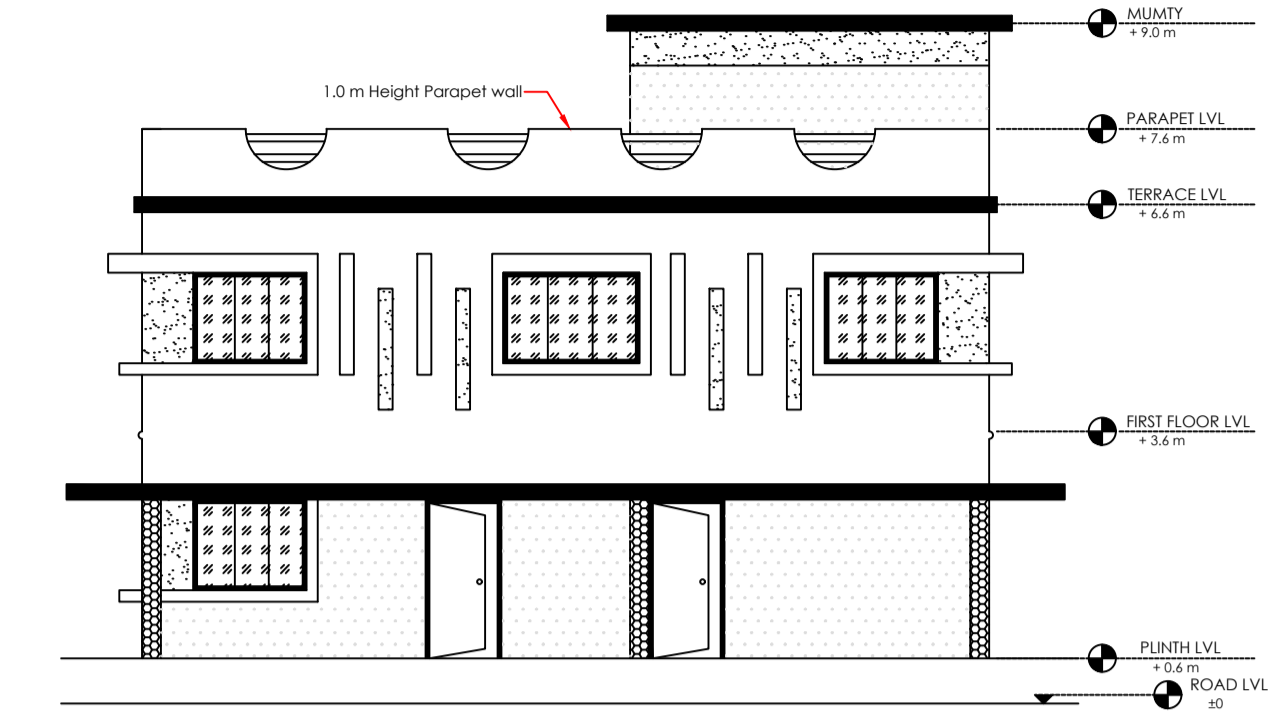

Floor Name	Building Name		Total	
	Proposed Built Up Area (Sq.mt.)	Proposed FAR Area (Sq.mt.)	Total Proposed Built Up Area (Sq.mt.)	Total FAR Area (Sq.mt.)
Ground Floor	139.56	86.87	139.56	86.87
First Floor	139.55	139.55	139.55	139.55
Terrace Floor	0.00	0.00	0.00	0.00
Total :	279.11	226.42	279.11	226.42

SCHEDULE OF DOOR:				
BUILDING NAME	NAME	LENGTH	HEIGHT	NOS
A (SANJEET KUMAR)	D3	0.90	2.10	11
A (SANJEET KUMAR)	D2	1.00	2.10	07
A (SANJEET KUMAR)	D1	1.00	2.10	02

  

SCHEDULE OF WINDOW/VENTILATION:				
BUILDING NAME	NAME	LENGTH	HEIGHT	NOS
A (SANJEET KUMAR)	V	1.00	1.20	09
A (SANJEET KUMAR)	W4	1.20	1.20	01
A (SANJEET KUMAR)	W3	1.50	1.20	12
A (SANJEET KUMAR)	W2	1.80	1.20	01
A (SANJEET KUMAR)	W1	3.00	1.20	01

FAR & Tenement Details (Table 4c-1)							
Building	No. of Same Bldg	Total Built Up Area (Sq.mt.)	Deductions (Area in Sq.mt.)	Proposed FAR Area (Sq.mt.)	Total FAR Area (Sq.mt.)	Total Consumed Additional FAR Area (Sq.mt.)	Trmt (No.)
A (SANJEET KUMAR)	1	279.11	52.69	226.42	226.42	226.42	01
Grand Total :	1	279.11	52.69	226.42	226.42	226.42	01

Building USE/SUBUSE Details			
Building Name	Building Use	Building SubUse	Building Structure
A (SANJEET KUMAR)	Residential	Bungalow/ Dwelling / Non Apartment	Non-Highrise

Building :A (SANJEET KUMAR)						
Floor Name	Total Built Up Area (Sq.mt.)	Deductions (Area in Sq.mt.)	Proposed FAR Area (Sq.mt.)	Total FAR Area (Sq.mt.)	Total Consumed Additional FAR Area (Sq.mt.)	Trmt (No.)
Ground Floor	139.56	52.69	86.87	86.87	86.87	01
First Floor	139.55	0.00	139.55	139.55	139.55	00
Terrace Floor	0.00	0.00	0.00	0.00	0.00	00
Total :	279.11	52.69	226.42	226.42	226.42	01
Total Number of Same Buildings :	1					
Total :	279.11	52.69	226.42	226.42	226.42	01

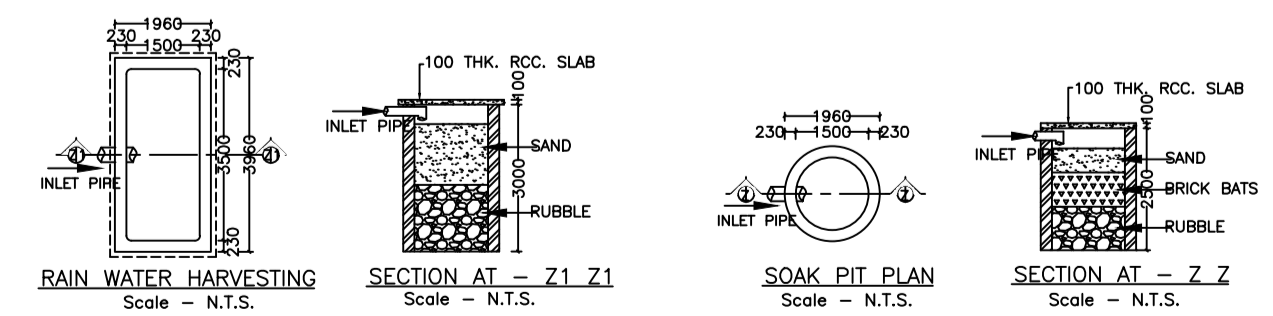

UnitBUA Table for Building :A (SANJEET KUMAR)						
FLOOR	Name	UnitBUA Type	UnitBUA Area	Carpet Area	No. of Rooms	No. of Tenement
GROUND FLOOR PLAN	SPLIT SANJEET KUMAR	FLAT	189.25	188.54	8	1
FIRST FLOOR PLAN	SPLIT SANJEET KUMAR	FLAT	0.00	0.00	11	0
Total:			189.25	188.54	19	1

COLOR INDEX	
PLOT BOUNDARY	Black
ABUTTING ROAD	Red
PROPOSED CONSTRUCTION	Green
COMMON PLOT	Blue
ROAD WIDENING AREA	Yellow
EXISTING (To be retained)	Light Blue
EXISTING (To be demolished)	Dark Blue

LTP NAME AND SIGNATURE	STRUCTURAL ENG'S NAME AND SIGNATURE	BUILDER NAME AND SIGNATURE	DIGITAL SIGNATURE
Manish Agarwal CMC/ARC/0003/2018			