

Project Title: PRIYANSHU KUMARI

AREA STATEMENT: CHAS MUNICIPAL CORPORATION	VERSION NO: 1.0.36
PROJECT DETAIL:	VERSION DATE: 16/10/2020
TRACT NO: -	Plot Use: Residential
Region: ANARWAD URBAN LOCAL BODIES	Plot Sub-Use: Bungalow Dwelling / Non Apartment
TRACT: BIKHARI	Land Use Zone: NA
Application Type: General Proposal	Abutting Road Width: -
Project Type: Building Permission	Plot No: -
Name of Development: New	Revenue Survey No/Survey No: -
Location: Use Area	Thana No: -
Sub Location: NA	Modeling No: -
Village/Moosa Name: -	Khata No: -
Ward No: -	North: -
Road Street: -	South: -
	East: -
	West: -

AREA DETAILS	
AREA OF PLOT (Minimum)	(A) SQ.MT. 102.23
Net Plot Area (Gross Plot Area - Deduction from Gross Plot Area)	(A-Deductions) 102.23
Deductions for Balance Plot Area (from Gross Plot Area)	
Yard	6.93
Balance Plot Area (Net Plot Area - Recreational/Amenity space)	(A-Deductions) 95.30
Plot Area for Coverage (Net Plot Area)	(A-Deductions) 102.23
Plot Area for FSI (Net Plot Area - Road/Walking Area)	(A-Deductions) 102.23
COVERED AREA CHECK:	
Proposed Coverage Area (65.66 %)	67.33
Total Coverage Area (65.66 %)	67.33
FAR CHECK:	
Proposed Area of FAR	67.33
Total Area of FAR	67.33
BUILT UP AREA CHECK:	
Net Proposed Built-up Area	67.33
AROH (ENGR) / SUPERVISOR (Regd)	OWNER
DEVELOPMENT AUTHORITY	LOCAL BODY

COLOR INDEX	
PLLOT BOUNDARY	
ABUTTING ROAD	
PROPOSED WORK (COVERAGE AREA)	
EXISTING (To be retained)	
EXISTING (To be demolished)	

MARGIN DETAIL:					
Building / Wing Name	Road Name	Front Margin	Rear Margin	Side Margin	Sold Margin
A (PRO BUILDING)	6.10 MTR WIDE ROAD	2.00	1.50	0.90	0.00

FAR & Tenement Details (Table 4c-1)					
Building	No. of Same Bldg	Total Built Up Area (Sq.m)	Proposed FAR Area (Sq.m)	Total FAR Area (Sq.m)	Tenent (No.)
A (PRO BUILDING)	1	67.33	67.33	67.33	01
Grand Total:	1	67.33	67.33	67.33	01

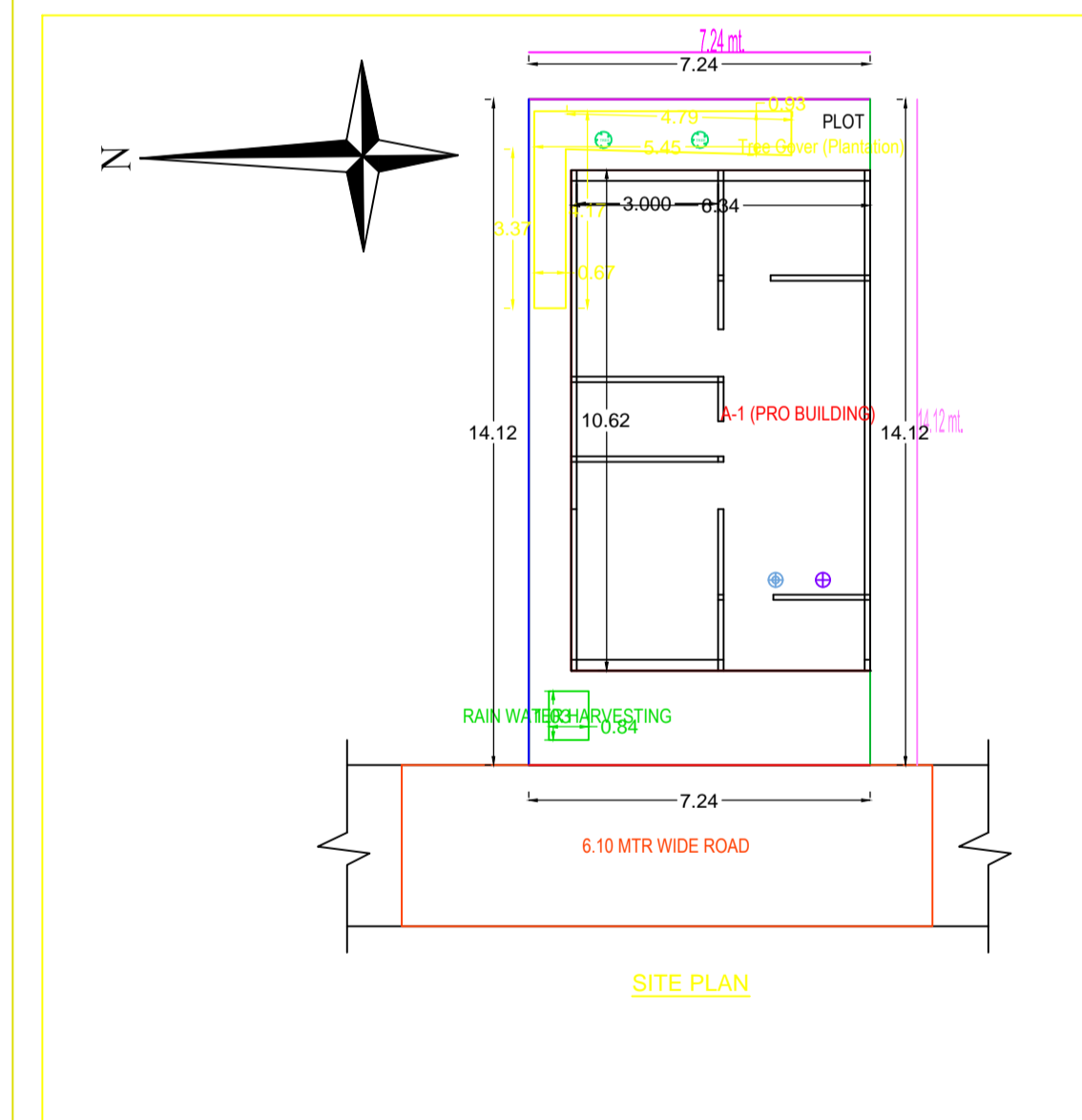
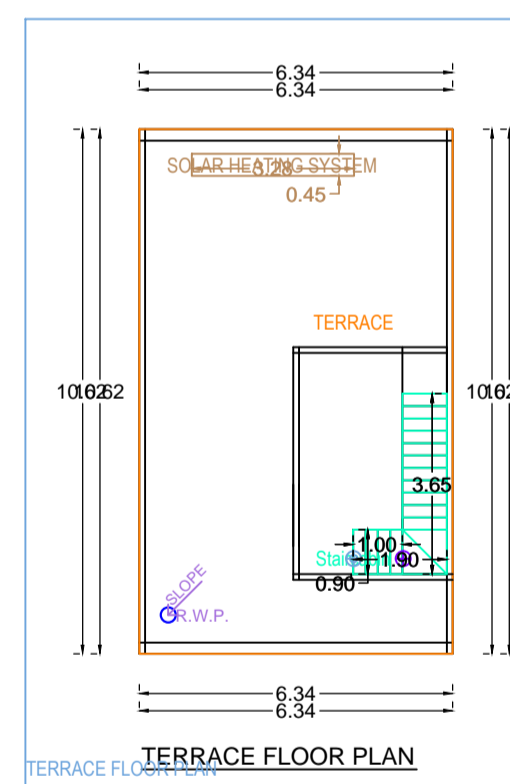
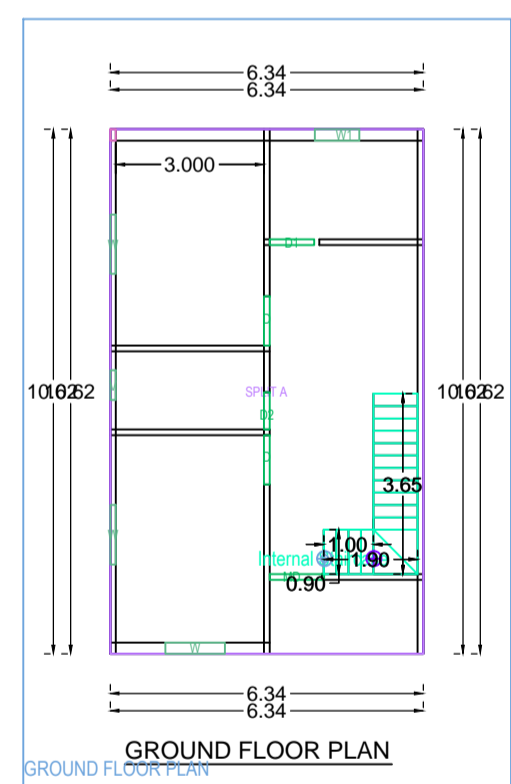
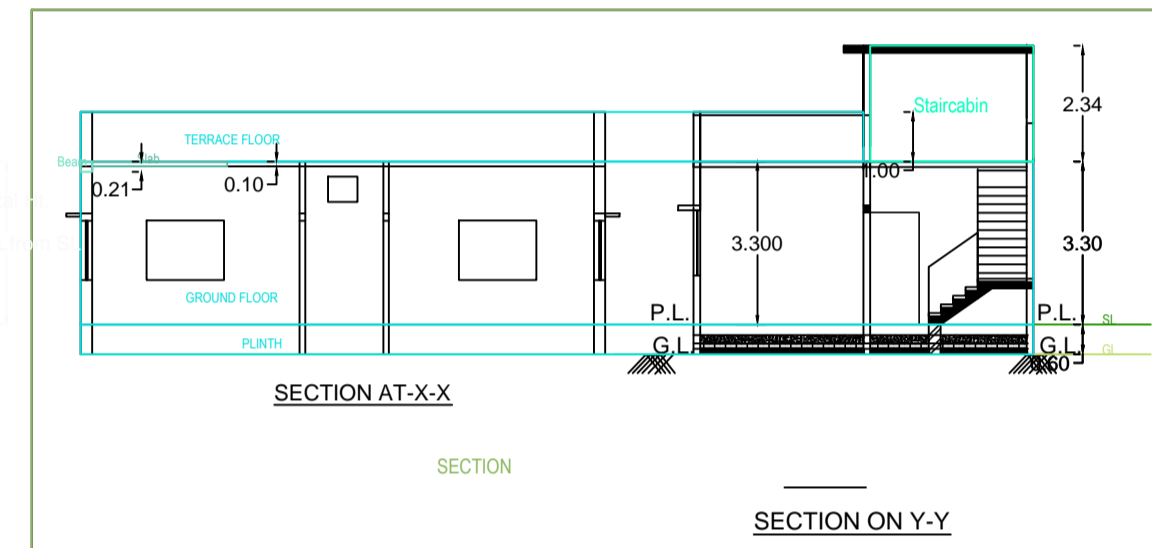
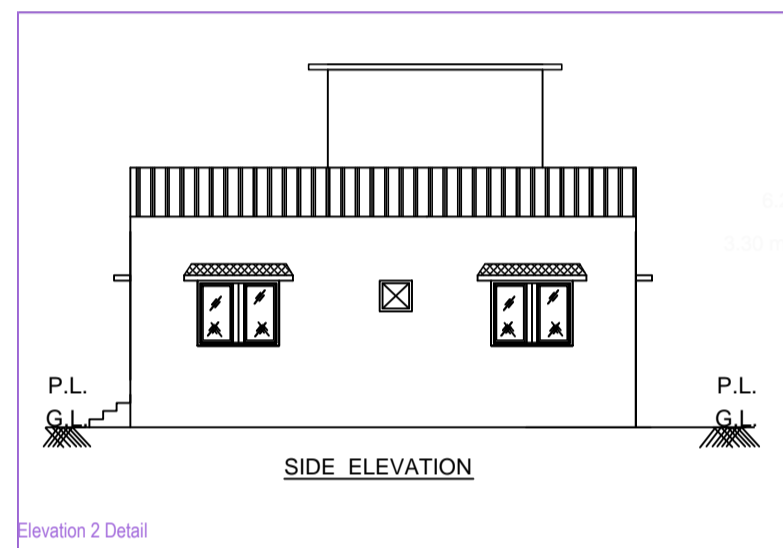
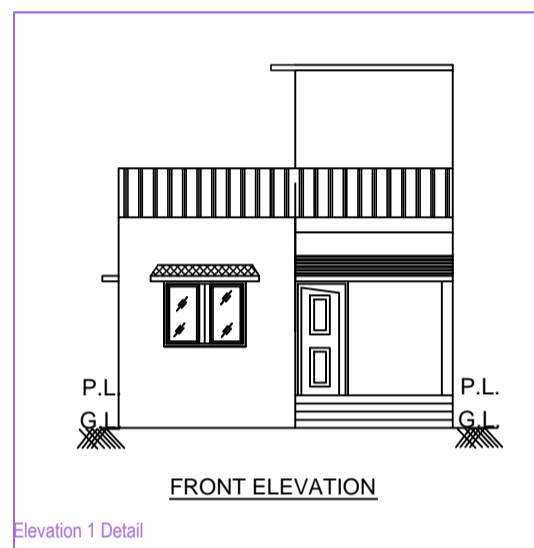
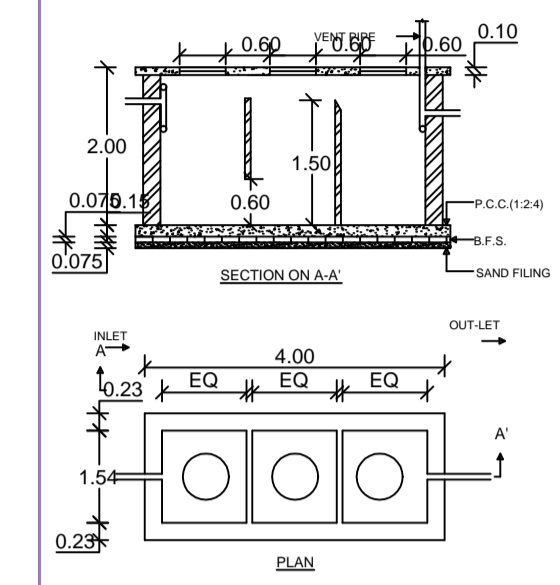
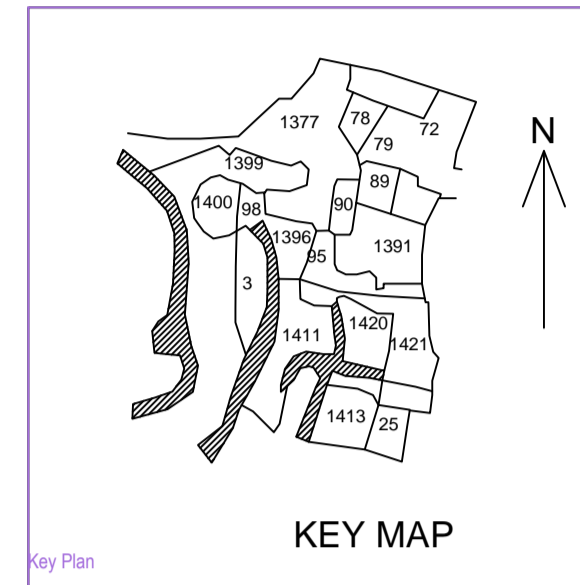
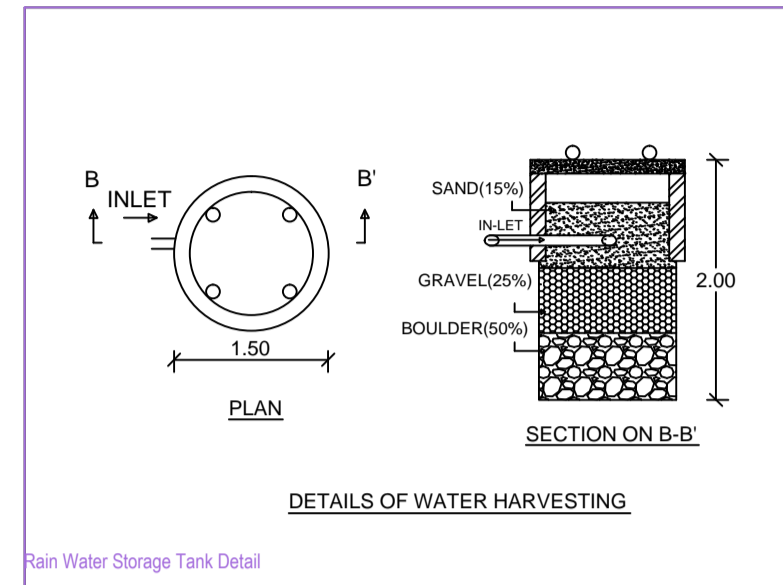
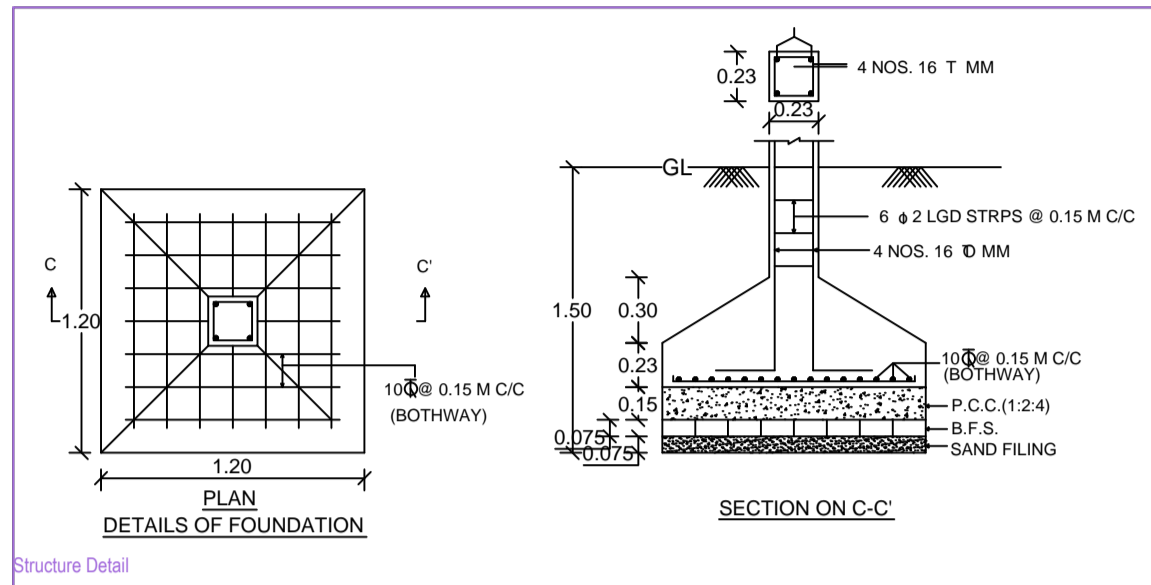

Building A (PRO BUILDING)

Floor Name	Total Built Up Area (Sq.m)	Proposed FAR Area (Sq.m)	Total FAR Area (Sq.m)	Tenent (No.)
Ground Floor	67.33	67.33	67.33	01
Terrace Floor	0.00	0.00	0.00	00
Total	67.33	67.33	67.33	01
Total Number of Same Buildings	1			
Total	67.33	67.33	67.33	01

SCHEDULE OF JOINERY:

BUILDING NAME	NAME	LENGTH	HEIGHT	NOS
A (PRO BUILDING)	D2	0.75	2.10	01
A (PRO BUILDING)	D1	0.90	2.10	01
A (PRO BUILDING)	D	1.00	2.10	02
A (PRO BUILDING)	MD	1.10	2.10	01
Total	-	-	-	05

SCHEDULE OF JOINERY:

BUILDING NAME	NAME	LENGTH	HEIGHT	NOS
A (PRO BUILDING)	V	0.80	1.50	01
A (PRO BUILDING)	W1	0.90	1.20	01
A (PRO BUILDING)	W	1.20	1.20	03
Total	-	-	-	05

UnitBUA Table for Building A (PRO BUILDING)

FLOOR	Name	UnitBUA Type	UnitBUA Area	Carpel Area	No. of Rooms	No. of Tenement
GROUND FLOOR PLAN	SPLITA	FLAT	67.33	67.30	6	1
Total	-	-	67.33	67.30	6	1