

Proposal Basic Information	
Proposal File No.	CMC/BP/0161/W03/2023
Owner Name	1.SNEHA SARAF 2.SHAMBHU KUMAR
Khata No	14 NEW KHATA NO. - 7
Plot No	284 NEW PLOT NO. - 515
Village Name	Phudnidih
Use	Residential
SubUse	Bungalow/ Dwelling / Non Apartment

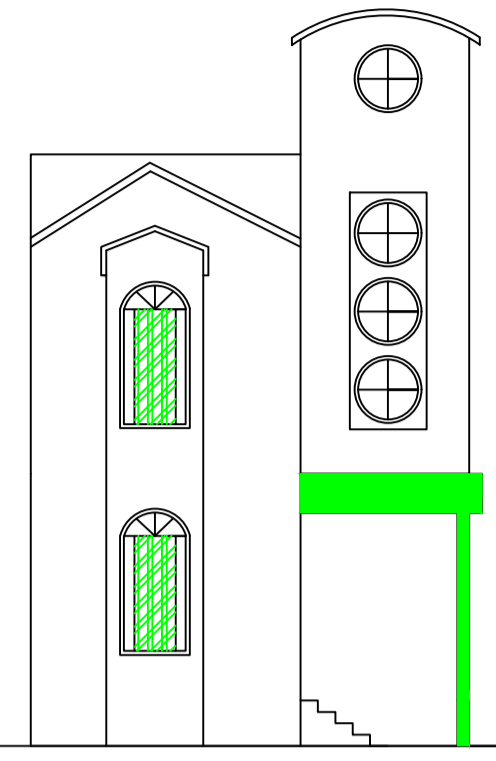

FRONT ELEVATION

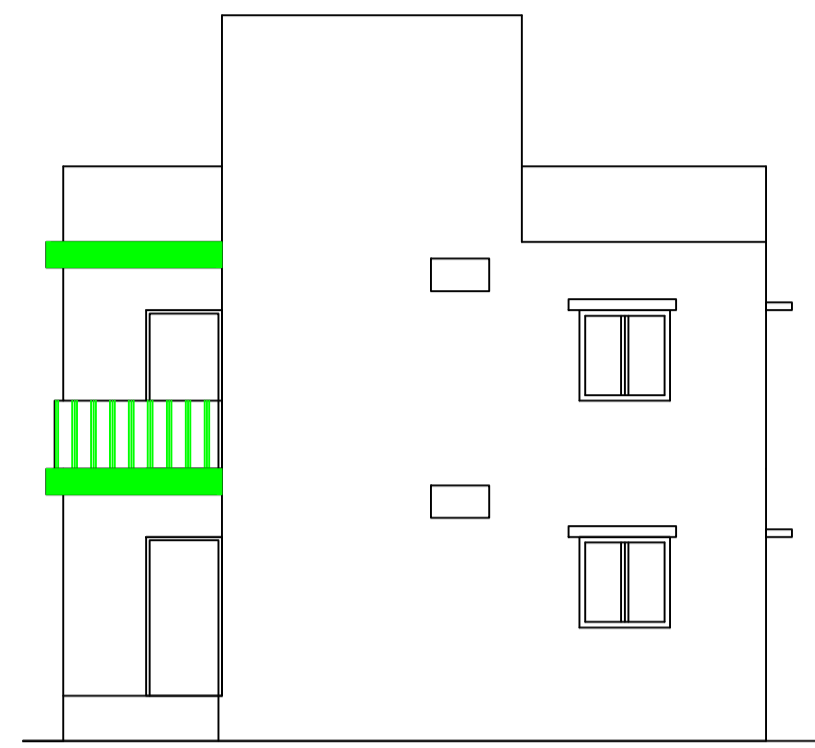

SIDE ELEVATION

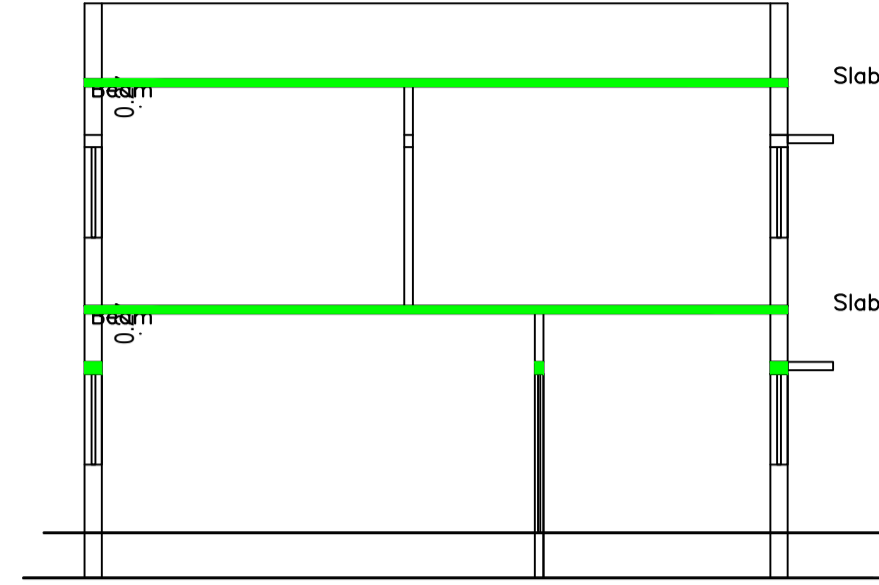

SECTION ON Y-Y

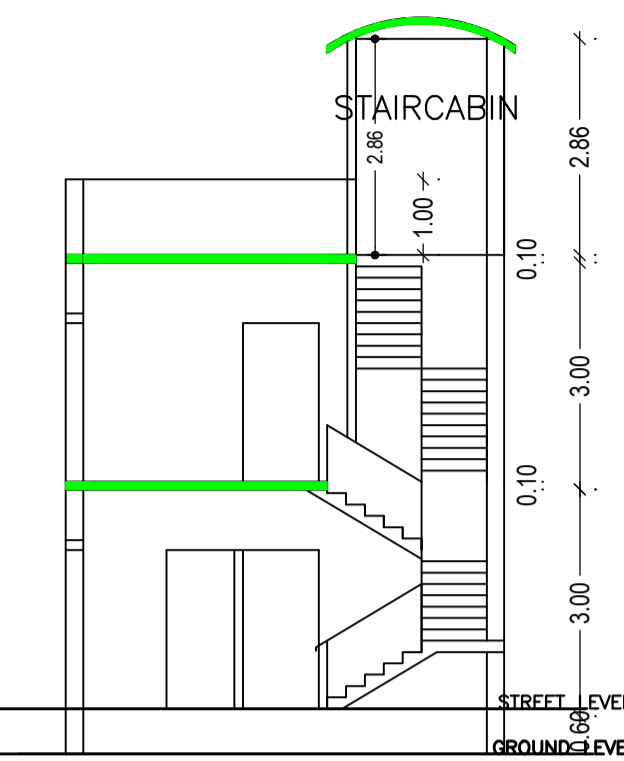

SECTION ON X-X

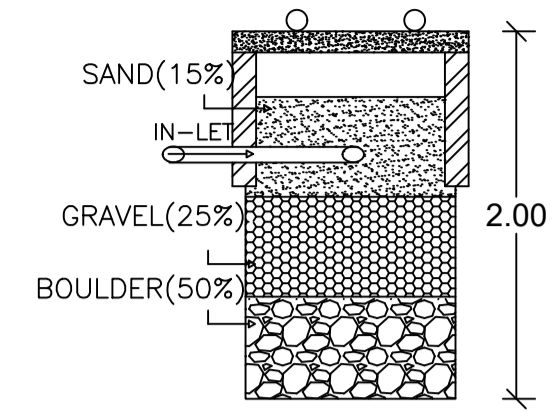

SECTION ON B-B'

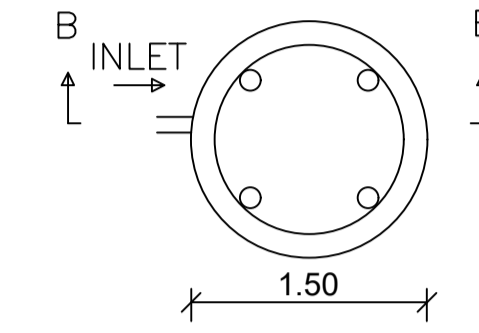

DETAILS OF WATER HARVESTING

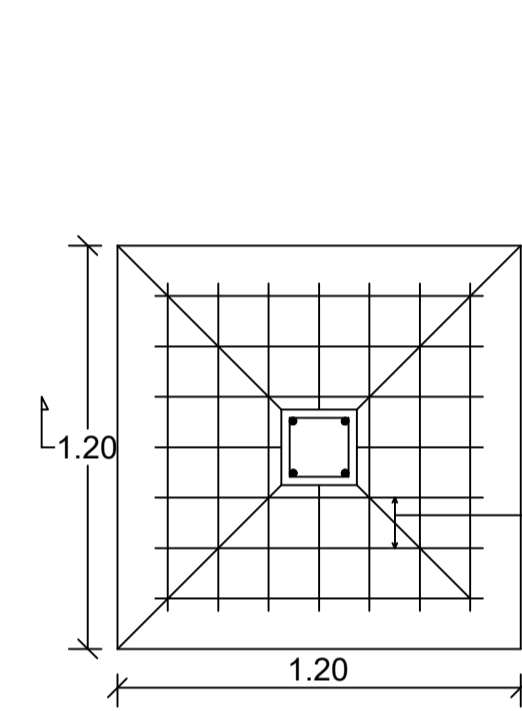

PLAN

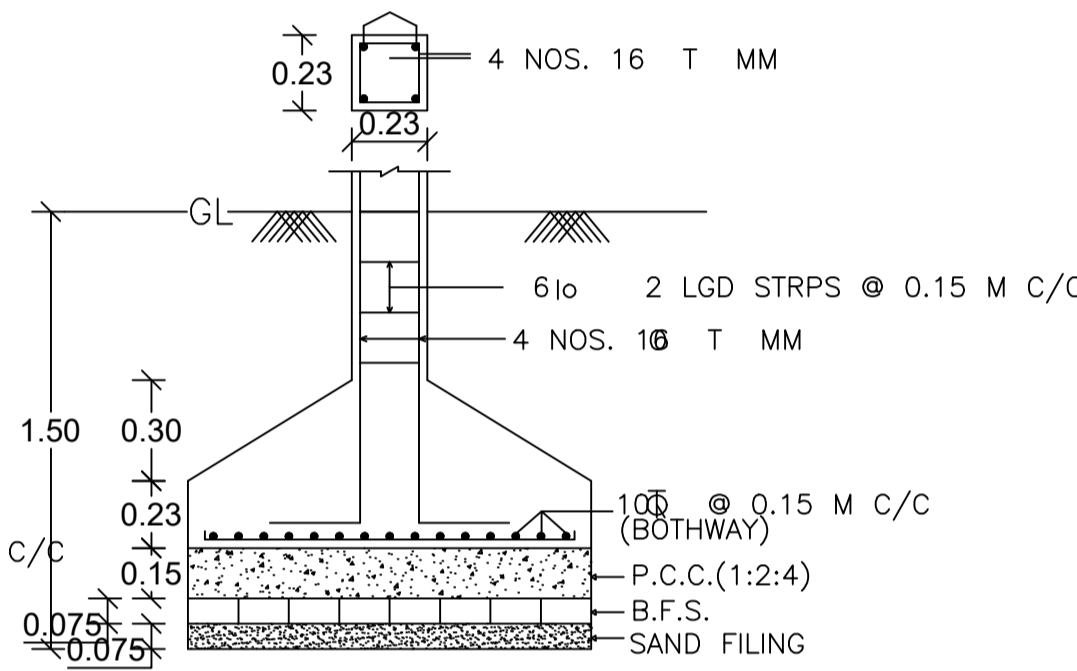

DETAILS OF FOUNDATION SECTION ON C-C'

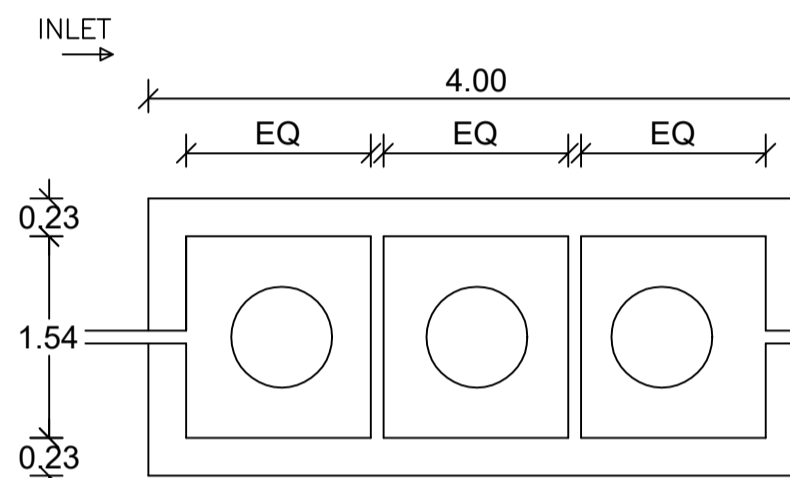

PLAN

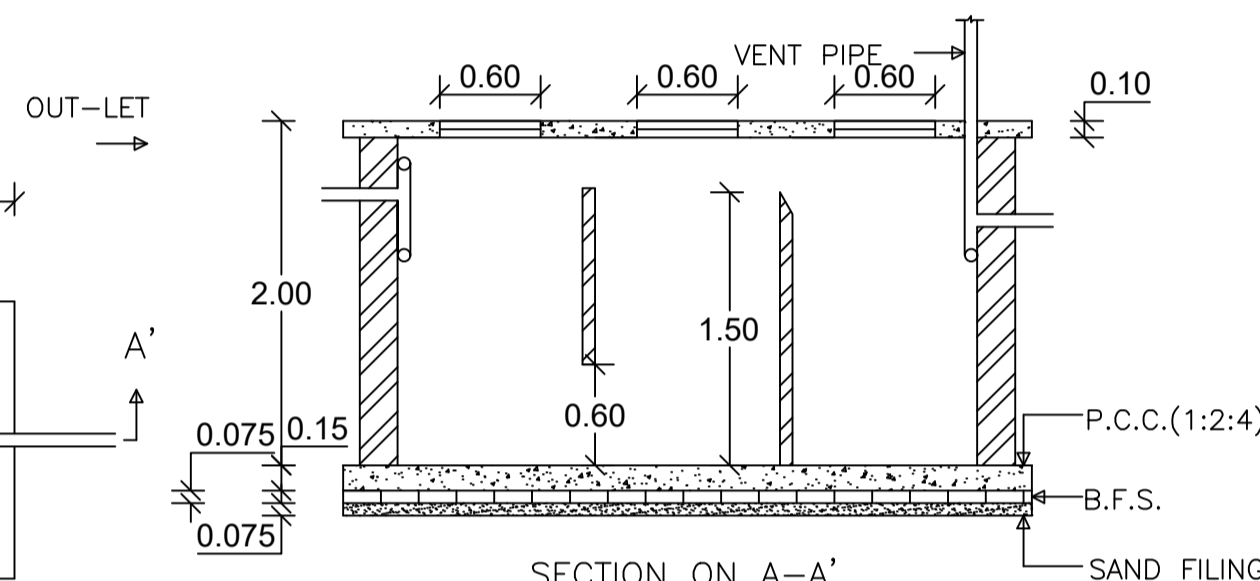

SECTION ON A-A' DETAILS OF SEPTIC TANK

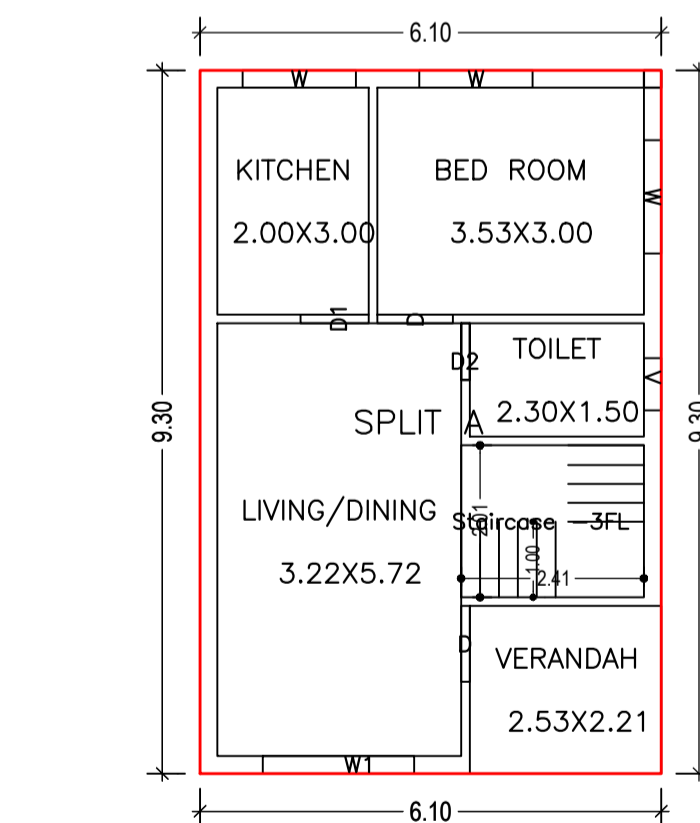

GROUND FLOOR PLAN (Proposed) (SCALE 1:100)

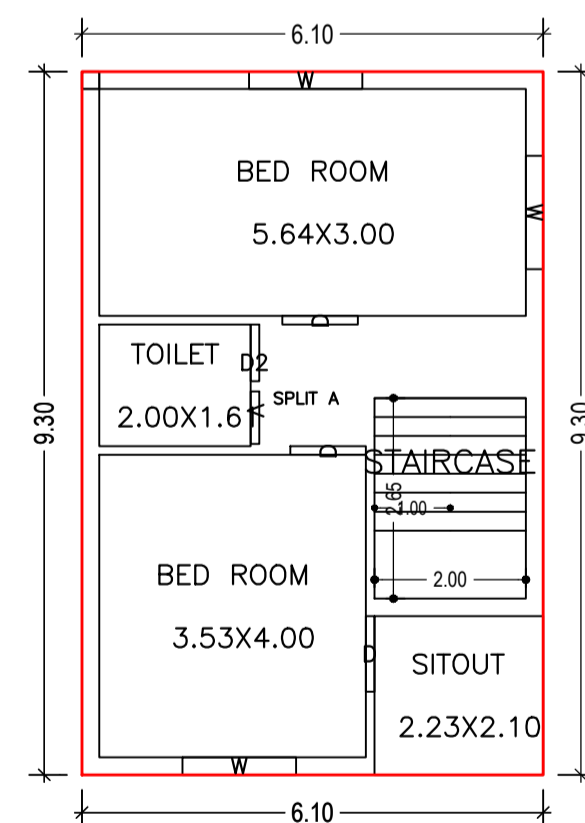

FIRST FLOOR PLAN (Proposed) (SCALE 1:100)

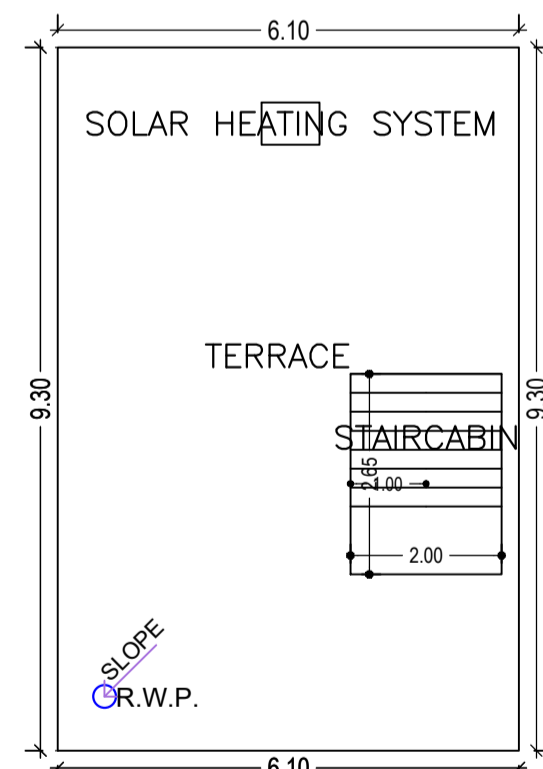

TERRACE FLOOR PLAN (SCALE 1:100)

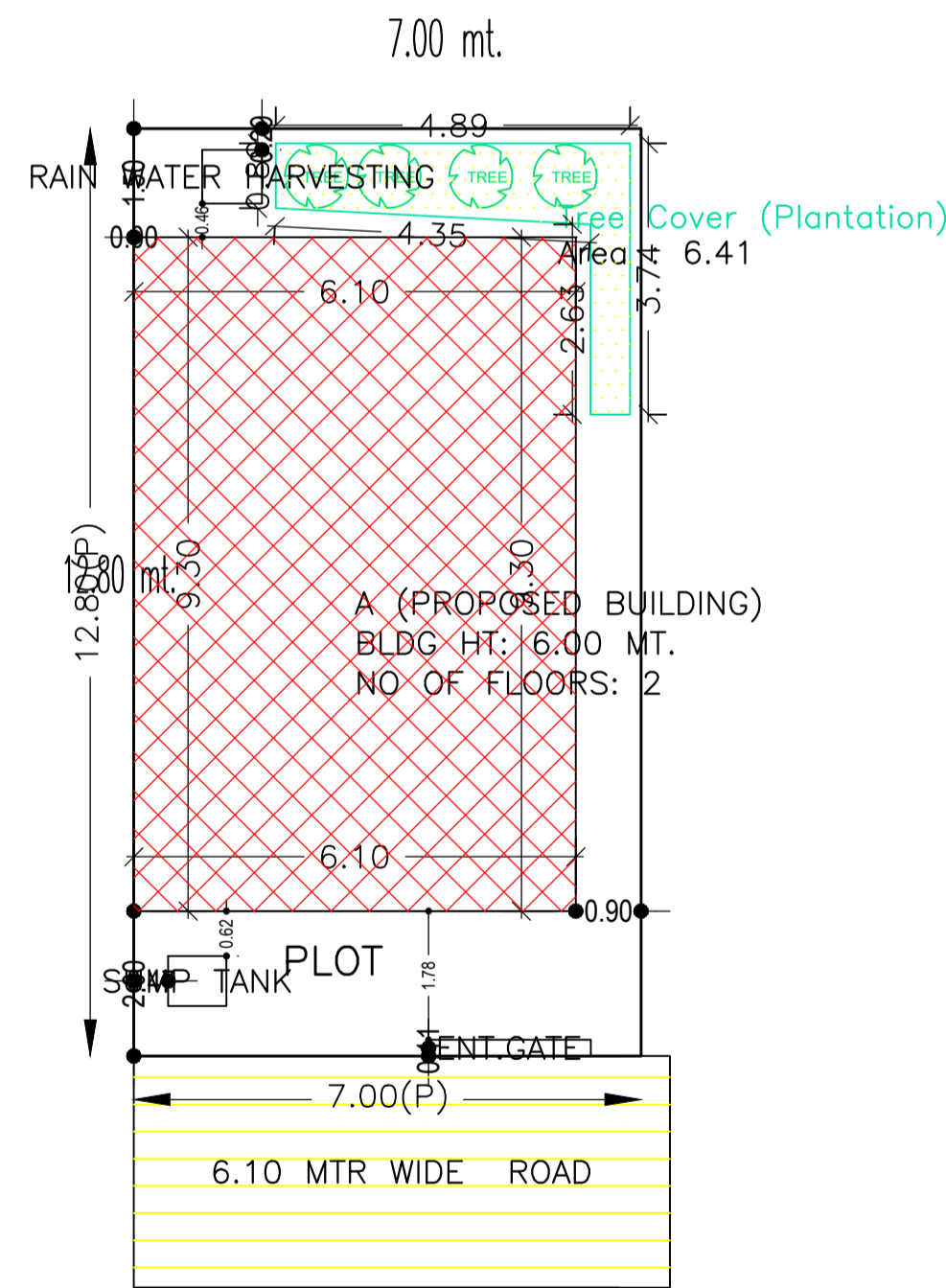

SITE PLAN

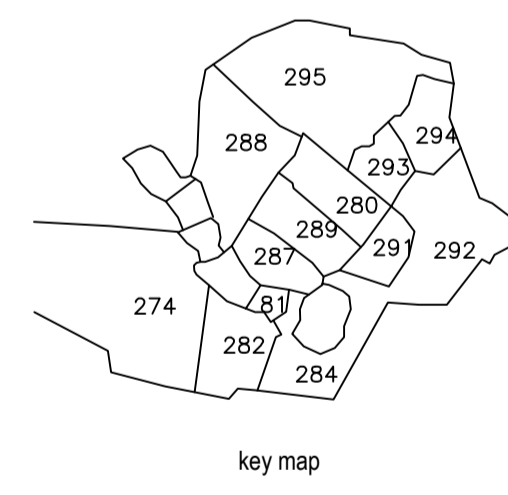

key map

AREA STATEMENT CHAS MUNICIPAL CORPORATION		VERSION NO. : 1.0.66
PROJECT DETAIL:		VERSION DATE: 16/10/2020
Region: JHARKHAND URBAN LOCAL BODIES	Plot Use: Residential	
District: BOKARO	Plot SubUse: Bungalow/ Dwelling / Non Apartment	
Authority: CHAS MUNICIPAL CORPORATION	PlotNearbyReligiousStructure: NA	
Inward No: CMC/BP/0161/W03/2023	Plot/SubPlot No: 284 NEW PLOT NO. - 515	
Application Type: General Proposal	North: CTS No. - SUNIL KANT AND OTHERS	
Project Type: Building Permission	South: Road Width - ROAD	
Nature of Development: New	East: Road Width - ROAD	
Location of Development Area: New Area	West: CTS No. - BOUNDARY WALL	
AREA OF PLOT (Minimum)	(A)	SQ.MT. 89.60
NET AREA OF PLOT (Gross Plot Area - Deduction from Gross Plot area)	(A-Deductions)	89.60
Deduction for Balance Plot Area (from Gross Plot Area)		
Common Plot		6.41
Total		6.41
BALANCE AREA OF PLOT (Net Plot Area - Recreational/Amenity space)	(A-Deductions)	83.19
PLOT AREA FOR COVERAGE (Net Plot Area)	(A-Deductions)	89.60
Plot Area for FAR (Net Plot Area + Road Widening Area)	(A-Deductions)	89.60
COVERAGE CHECK		
Permissible Coverage area (70.00 %)		62.72
Proposed Coverage Area (63.31 %)		56.73
Total Prop. Coverage Area (63.31 %)		56.73
Balance coverage area (6.69 %)		5.99
FAR CHECK		
Perm. FAR Area (2.000)		179.20
Total Perm. FAR area		179.20
Residential FAR		113.46
Proposed FAR Area		113.46
Total Proposed FAR Area		113.46
Consumed FAR (Factor)		1.27
Balance FAR Area		65.74
BUILT UP AREA CHECK		
Total Proposed BuiltUp Area		113.46
ARCHITECT (Regd)	AMRIT KUMAR MAHATO	
ENGINEER (Regd)		
SUPERVISOR (Regd)		
OWNER (Regd)	1.SNEHA SARAF 2.SHAMBHU KUMAR	
DEVELOPMENT AUTHORITY		LOCAL BODY

Building :A (PROPOSED BUILDING)

Floor Name	Total Built Up Area (Sq.mt.)	Proposed FAR Area (Sq.mt.) Resi.	Total FAR Area (Sq.mt.)	Total Consumed Additional FAR Area (Sq.mt.)	Tnmt (No.)
Ground Floor	56.73	56.73	56.73	56.73	01
First Floor	56.73	56.73	56.73	56.73	00
Terrace Floor	0.00	0.00	0.00	0.00	00
Total :	113.46	113.46	113.46	113.46	01
Total Number of Same Buildings	1				
Total :	113.46	113.46	113.46	113.46	01

FAR & Tenement Details (Table 4c-1)

Building	No. of Same Bldg	Total Built Up Area (Sq.mt.)	Proposed FAR Area (Sq.mt.) Resi.	Total FAR Area (Sq.mt.)	Total Consumed Additional FAR Area (Sq.mt.)	Tnmt (No.)
A (PROPOSED BUILDING)	1	113.46	113.46	113.46	113.46	01
Grand Total :	1	113.46	113.46	113.46	113.46	01

SCHEDULE OF DOOR:

BUILDING NAME	NAME	LENGTH	HEIGHT	NOS
A (PROPOSED BUILDING)	D2	0.75	2.10	02
A (PROPOSED BUILDING)	D1	0.90	2.10	01
A (PROPOSED BUILDING)	D	1.00	2.10	05

SCHEDULE OF WINDOW/VENTILATION:

BUILDING NAME	NAME	LENGTH	HEIGHT	NOS
A (PROPOSED BUILDING)	V	0.69	1.20	02
A (PROPOSED BUILDING)	W	1.50	1.20	06
A (PROPOSED BUILDING)	W1	2.00	1.20	01

UnitBUA Table for Building :A (PROPOSED BUILDING)

FLOOR	Name	UnitBUA Type	UnitBUA Area	Carpet Area	No. of Rooms	No. of Tenement
GROUND FLOOR PLAN	SPLIT A	FLAT	113.46	113.27	5	1
FIRST FLOOR PLAN	SPLIT A	FLAT	0.00	0.00	4	0
Total:	-	-	113.46	113.27	9	1

Buildingwise Floor FAR Details

Floor Name	Building Name A (PROPOSED BUILDING)		Total	
	Proposed Built Up Area (Sq.mt.)	Proposed FAR Area (Sq.mt.)	Total Proposed Built Up Area (Sq.mt.)	Total FAR Area (Sq.mt.)
Ground Floor	56.73	56.73	56.73	56.73
First Floor	56.73	56.73	56.73	56.73
Terrace Floor	0.00	0.00	0.00	0.00
Total :	113.46	113.46	113.46	113.46

Building USE/SUBUSE Details

Building Name	Building Use	Building SubUse	Building Structure
A (PROPOSED BUILDING)	Residential	Bungalow/ Dwelling / Non Apartment	Non-Highrise

COLOR INDEX

PLOT BOUNDARY	[Red Line]
ABUTTING ROAD	[Green Line]
PROPOSED CONSTRUCTION	[Yellow Line]
COMMON PLOT	[Blue Line]
ROAD WIDENING AREA	[Orange Line]
EXISTING (To be retained)	[Grey Line]
EXISTING (To be demolished)	[Black Line]

LTP NAME AND SIGNATURE	STRUCTURAL ENG'S NAME AND SIGNATURE	BUILDER NAME AND SIGNATURE	DIGITAL SIGNATURE
AMRIT KUMAR MAHATO CMC/DFTMN/004/2019			