

Proposal Basic Information

Proposal File No.	CMC/BP/0135/W03/2023
Owner Name	1. POONAM DEVI 2. SUDHIR KUMAR SINGH
Khata No.	07 NEW KHATA NO. -53
Plot No.	282 NEW PLOT NO.-514
Village Name	Phrudidih
Use	Residential
SubUse	Bungalow/ Dwelling / Non Apartment

AREA STATEMENT CHAS MUNICIPAL CORPORATION

VERSION NO.:	1.0.66	
VERSION DATE:	16/10/2020	
PROJECT DETAIL:		
Region: JHARKHAND URBAN LOCAL BODIES:	Plot Use: Residential	
District: BOKARO	Plot SubUse: Bungalow/ Dwelling / Non Apartment	
Authority: CHAS MUNICIPAL CORPORATION	PlotNearby/ReligiousStructure: NA	
Inward_No: CMC/BP/0135/W03/2023	Plot/SubPlot No: 282 NEW PLOT NO.-514	
Application Type: General Proposal	North: CTS No. - NIJ	
Project Type: Building Permission	South: CTS No. - ANITA DEVI	
Nature of Development: New	East: CTS No. - NANHE KUMAR SINGH	
Location of Development Area: New Area	West: Road Width - ROAD	
AREA DETAILS:		
AREA OF PLOT (Minimum)	(A)	SQ.MT.
NET AREA OF PLOT(Gross Plot Area - Deduction from Gross Plot area)	(A-Deductions)	102.23
Deduction for Balance Plot Area(from Gross Plot Area)		
Common Plot		6.93
Total		6.93
BALANCE AREA OF PLOT(Net Plot Area - Recreational/Amenity space)	(A-Deductions)	95.30
PLOT AREA FOR COVERAGE(Net Plot Area)	(A-Deductions)	102.23
Plot Area for FAR (Net Plot Area + Road Widening Area)	(A-Deductions)	102.23
COVERAGE CHECK		
Permissible Coverage area (70.00 %)		71.56
Proposed Coverage Area (65.86 %)		67.33
Total Prop. Coverage Area (65.86 %)		67.33
Balance coverage area (4.14 %)		4.23
FAR CHECK		
Perm. FAR Area (2.000)		204.46
Total Perm. FAR area		204.46
Residential FAR		134.66
Proposed FAR Area		134.66
Total Proposed FAR Area		134.66
Consumed FAR (Factor)		1.32
Balance FAR Area		69.80
BUILT UP AREA CHECK		
Total Proposed BuiltUp Area		134.66
ARCHITECT (Regd)		AMRIT KUMAR MAHATO
ENGINEER (Regd)		
SUPERVISOR (Regd)		
OWNER (Regd)		1. POONAM DEVI 2. SUDHIR KUMAR SINGH
DEVELOPMENT AUTHORITY		LOCAL BODY

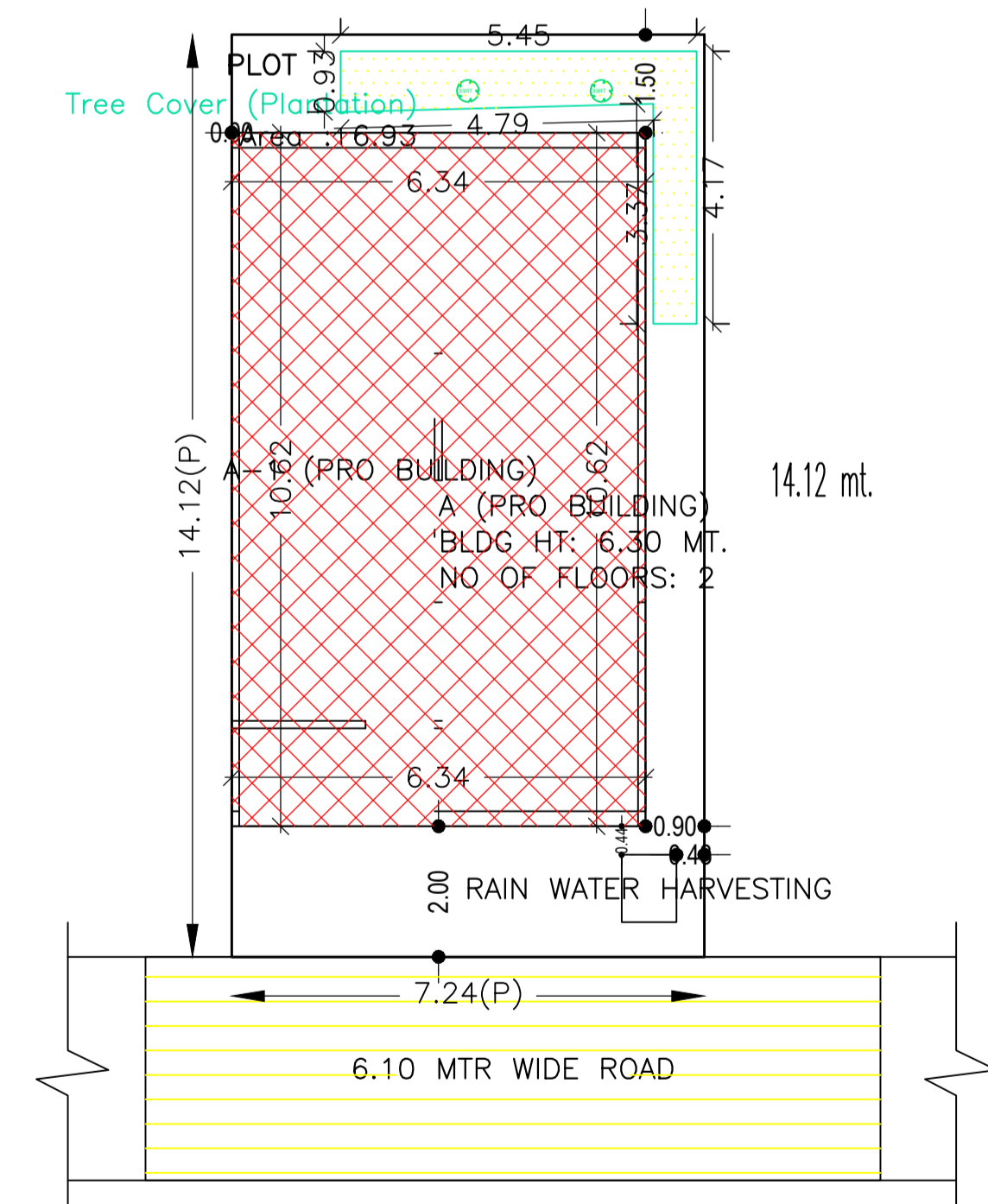
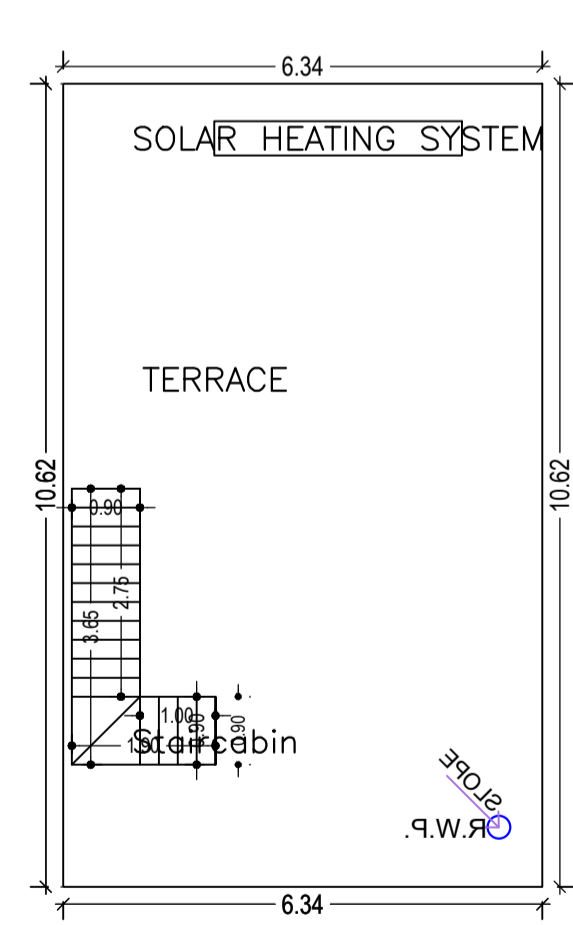
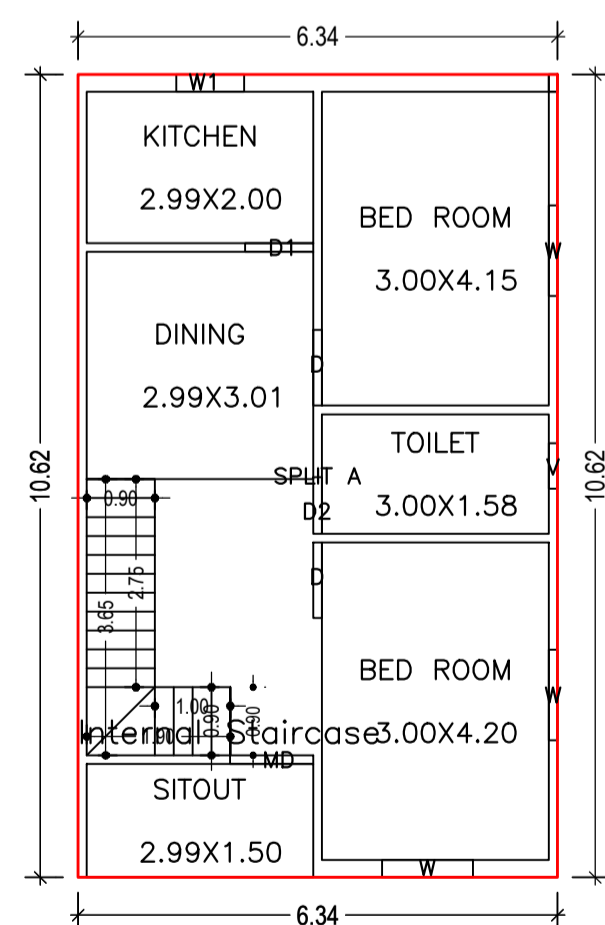
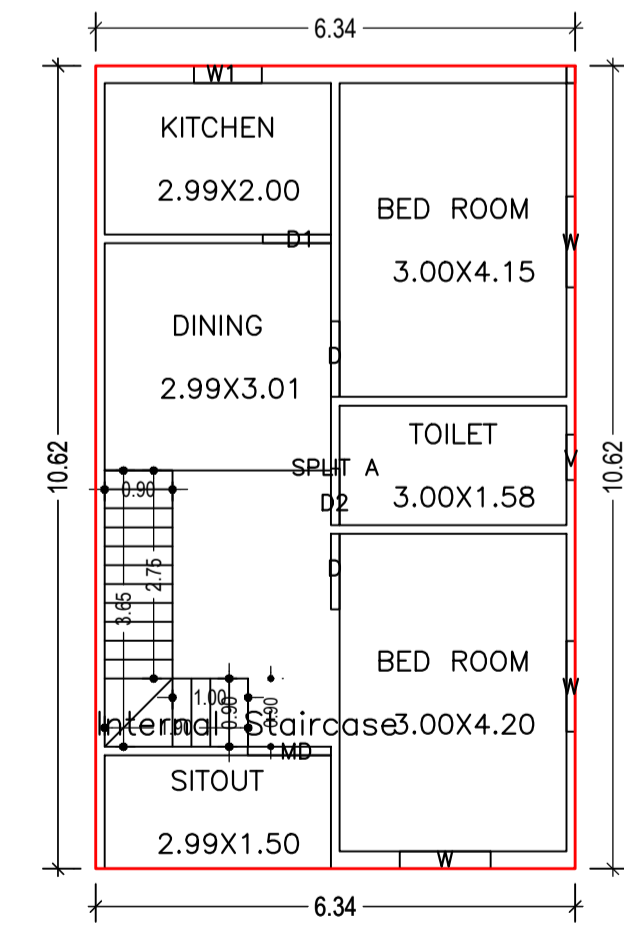
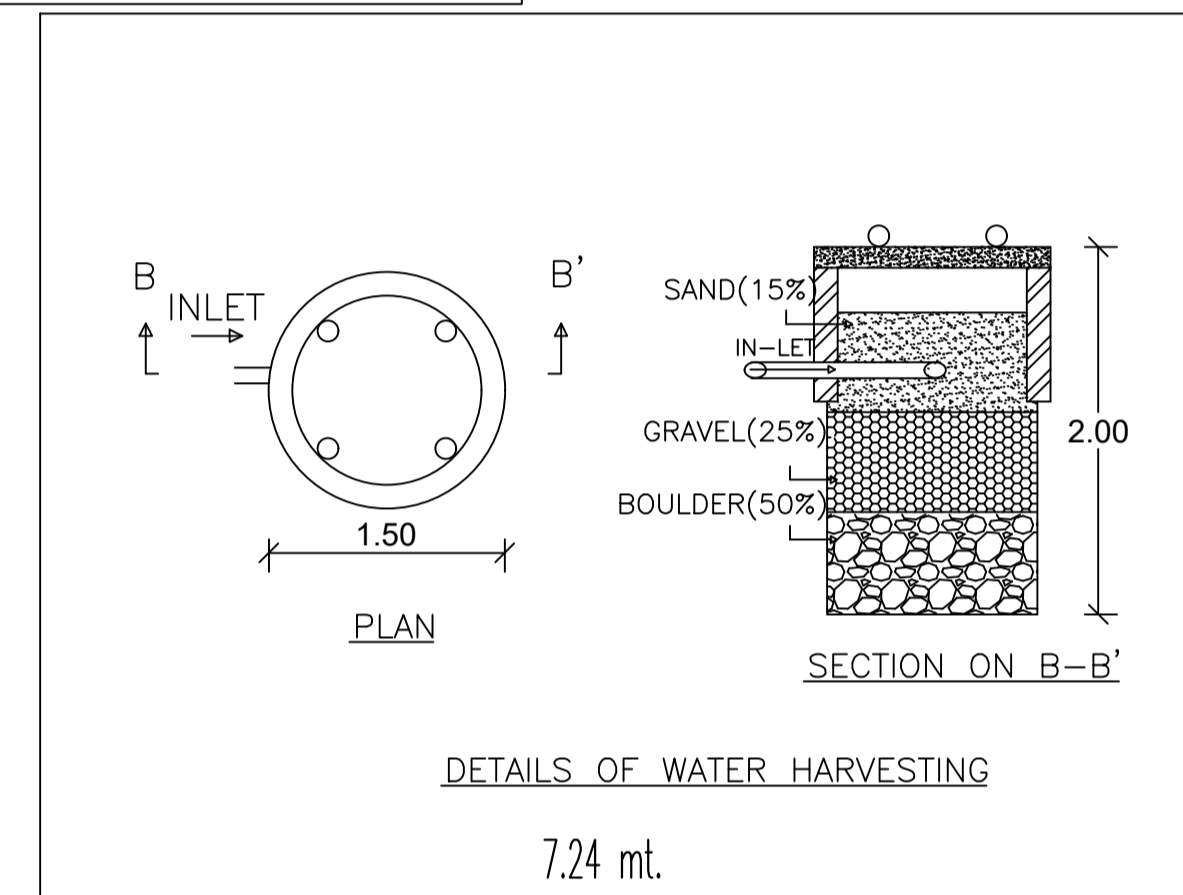
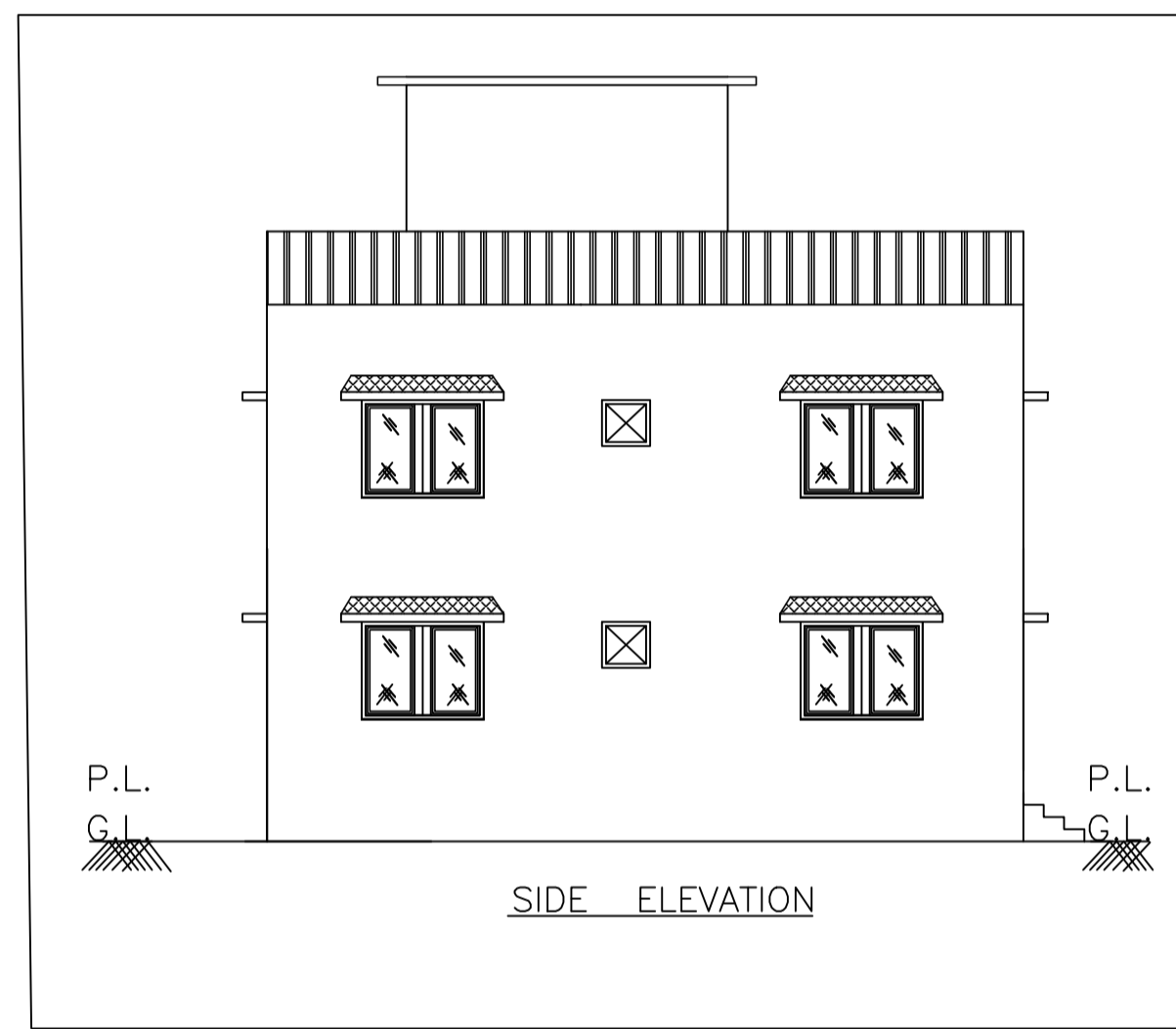
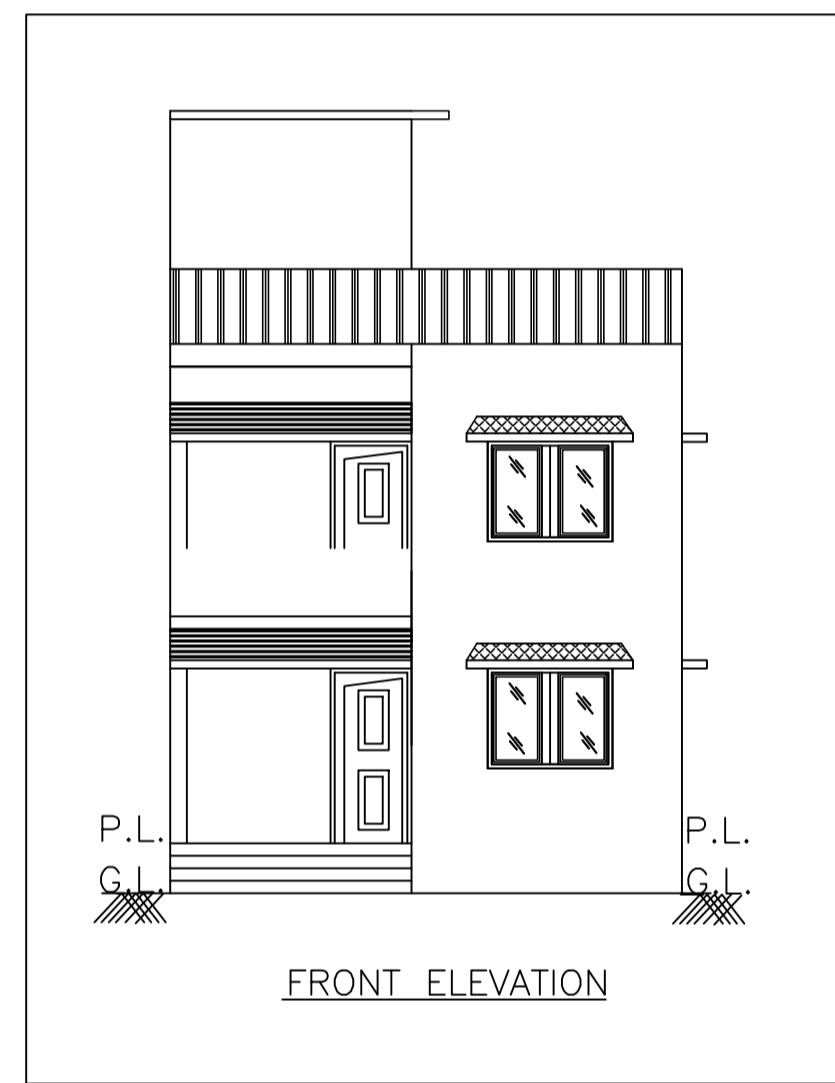
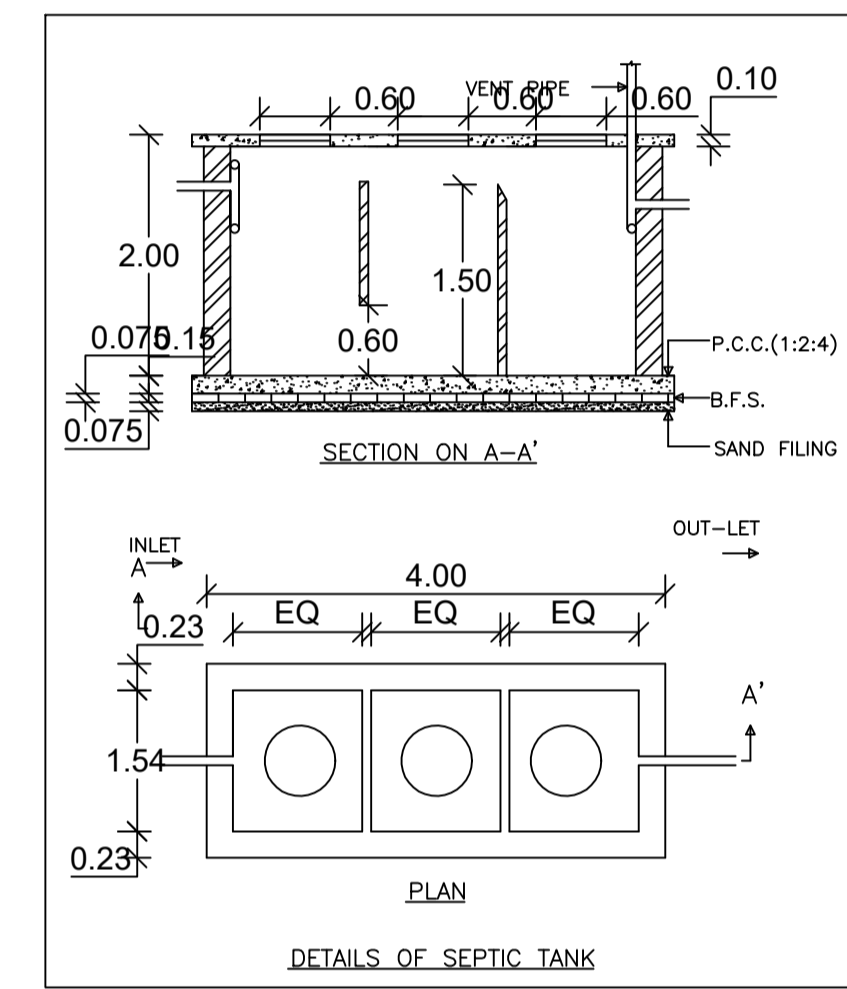

SCHEDULE OF DOOR:

BUILDING NAME	NAME	LENGTH	HEIGHT	NOS
A (PRO BUILDING)	D2	0.75	2.10	02
A (PRO BUILDING)	D1	0.90	2.10	02
A (PRO BUILDING)	D	1.00	2.10	04
A (PRO BUILDING)	MD	1.10	2.10	02

SCHEDULE OF WINDOW/VENTILATION:

BUILDING NAME	NAME	LENGTH	HEIGHT	NOS
A (PRO BUILDING)	V	0.60	1.20	02
A (PRO BUILDING)	W1	0.90	1.20	02
A (PRO BUILDING)	W	1.20	1.20	06

FAR & Tenement Details (Table 4c-1)

Building	No. of Same Bldg	Total Built Up Area (Sq.mt.)	Proposed FAR Area (Sq.mt.) Resi.	Total FAR Area (Sq.mt.)	Total Consumed Additional FAR Area (Sq.mt.)	Trnmt (No.)
A (PRO BUILDING)	1	134.66	134.66	134.66	134.66	01
Grand Total:	1	134.66	134.66	134.66	134.66	01

Building :A (PRO BUILDING)

Floor Name	Total Built Up Area (Sq.mt.)	Proposed FAR Area (Sq.mt.) Resi.	Total FAR Area (Sq.mt.)	Total Consumed Additional FAR Area (Sq.mt.)	Trnmt (No.)
Ground Floor	67.33	67.33	67.33	67.33	01
First Floor	67.33	67.33	67.33	67.33	00
Terrace Floor	0.00	0.00	0.00	0.00	00
Total:	134.66	134.66	134.66	134.66	01
Total Number of Same Buildings	1				
Total:	134.66	134.66	134.66	134.66	01

Building USE/SUBUSE Details

Building Name	Building Use	Building SubUse	Building Structure
A (PRO BUILDING)	Residential	Bungalow/ Dwelling / Non Apartment	Non-Highrise

UnitBUA Table for Building :A (PRO BUILDING)

FLOOR	Name	UnitBUA Type	UnitBUA Area	Carpet Area	No. of Rooms	No. of Tenement
GROUND FLOOR PLAN	SPLIT A	FLAT	134.66	134.61	6	1
FIRST FLOOR PLAN	SPLIT A	FLAT	0.00	0.00	6	0
Total:	-	-	134.66	134.61	12	1

Buildingwise Floor FAR Details

Floor Name	Building Name A (PRO BUILDING)		Total	
	Proposed Built Up Area (Sq.mt.)	Proposed FAR Area (Sq.mt.)	Total Proposed Built Up Area (Sq.mt.)	Total FAR Area (Sq.mt.)
Ground Floor	67.33	67.33	67.33	67.33
First Floor	67.33	67.33	67.33	67.33
Terrace Floor	0.00	0.00	0.00	0.00
Total:	134.66	134.66	134.66	134.66

COLOR INDEX

PLOT BOUNDARY	Black
ABUTTING ROAD	Red
PROPOSED CONSTRUCTION	Green
COMMON PLOT	Yellow
ROAD WIDENING AREA	Blue
EXISTING (To be retained)	Orange
EXISTING (To be demolished)	Purple

LTP NAME AND SIGNATURE	STRUCTURAL ENG'S NAME AND SIGNATURE	BUILDER NAME AND SIGNATURE	DIGITAL SIGNATURE
AMRIT KUMAR MAHATO CMC/DFTM/0004/2019			