

Proposal Basic Information	
Proposal File No.	CMC/BP/0142/W31/2023
Owner Name	MONITA VERMA
Khata No	389
Plot No	1760
Village Name	Kandra
Use	Residential
SubUse	Bungalow/ Dwelling / Non Apartment

AREA STATEMENT CHAS MUNICIPAL CORPORATION		VERSION NO. 1.0.66	VERSION DATE: 16/10/2020
PROJECT DETAIL:			
Region: JHARKHAND URBAN LOCAL BODIES	Plot Use: Residential		
District: BOKARO	Plot SubUse: Bungalow/ Dwelling / Non Apartment		
Authority: CHAS MUNICIPAL CORPORATION	PlotNearby/ReligiousStructure: NA		
Inward No: CMC/BP/0142/W31/2023	Plot/SubPlot No: 1760		
Application Type: General Proposal	North: CTS No. - NIRANJAN SINGH		
Project Type: Building Permission	South: Road Width - 7.31 MTR WIDE ROAD		
Nature of Development: New	East: Plot No. - PART OF PLOT		
Location of Development Area: New Area	West: CTS No. - NU		
AREA DETAILS:			
AREA OF PLOT (Minimum)	(A)		SQ. MT.
NET AREA OF PLOT(Gross Plot Area - Deduction from Gross Plot area)	(A-Deductions)		182.18
Deduction for Balance Plot Area(from Gross Plot Area)			
Common Plot			11.15
Total			11.15
BALANCE AREA OF PLOT(Net Plot Area - Recreational/Amenity space)	(A-Deductions)		171.03
PLOT AREA FOR COVERAGE(Net Plot Area)	(A-Deductions)		182.18
Plot Area for FAR (Net Plot Area + Road/Widening Area)	(A-Deductions)		182.18
COVERAGE CHECK			
Permissible Coverage area (70.00 %)			127.53
Proposed Coverage Area (65.62 %)			119.54
Total Prop. Coverage Area (65.62 %)			119.54
Balance coverage area (4.39 %)			7.99
FAR CHECK			
Perm. FAR Area (2.000)			364.36
Total Perm. FAR area			364.36
Residential FAR			358.32
Proposed FAR Area			358.32
Total Proposed FAR Area			358.32
Consumed FAR (Factor)			1.97
Balance FAR Area			6.04
BUILT UP AREA CHECK			
Total Proposed BuiltUp Area			370.60
ARCHITECT (Regd)		DINABANDHU RAJAK	
ENGINEER (Regd)			
SUPERVISOR (Regd)		MONITA VERMA	
OWNER (Regd)			
DEVELOPMENT AUTHORITY		LOCAL BODY	

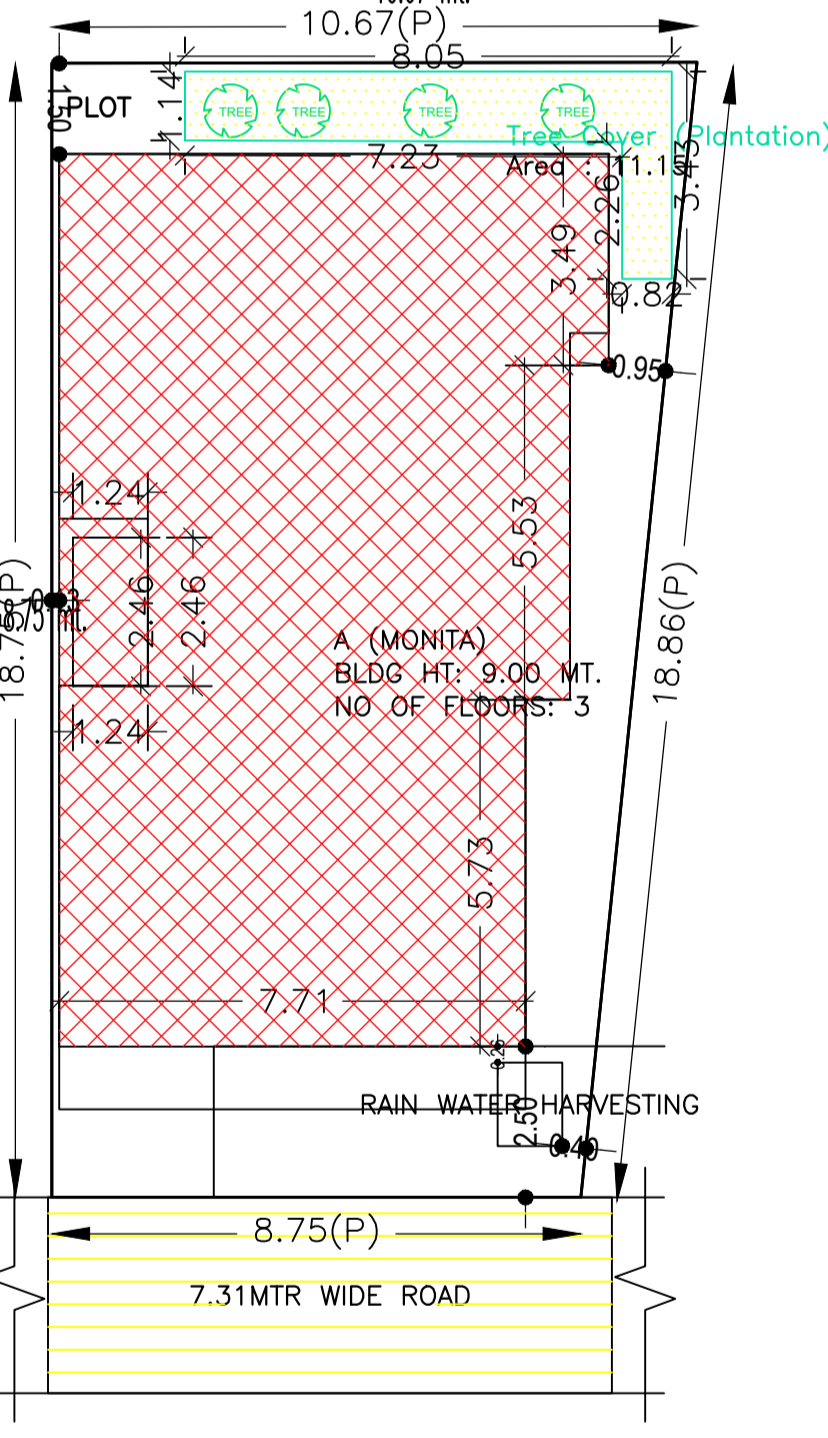
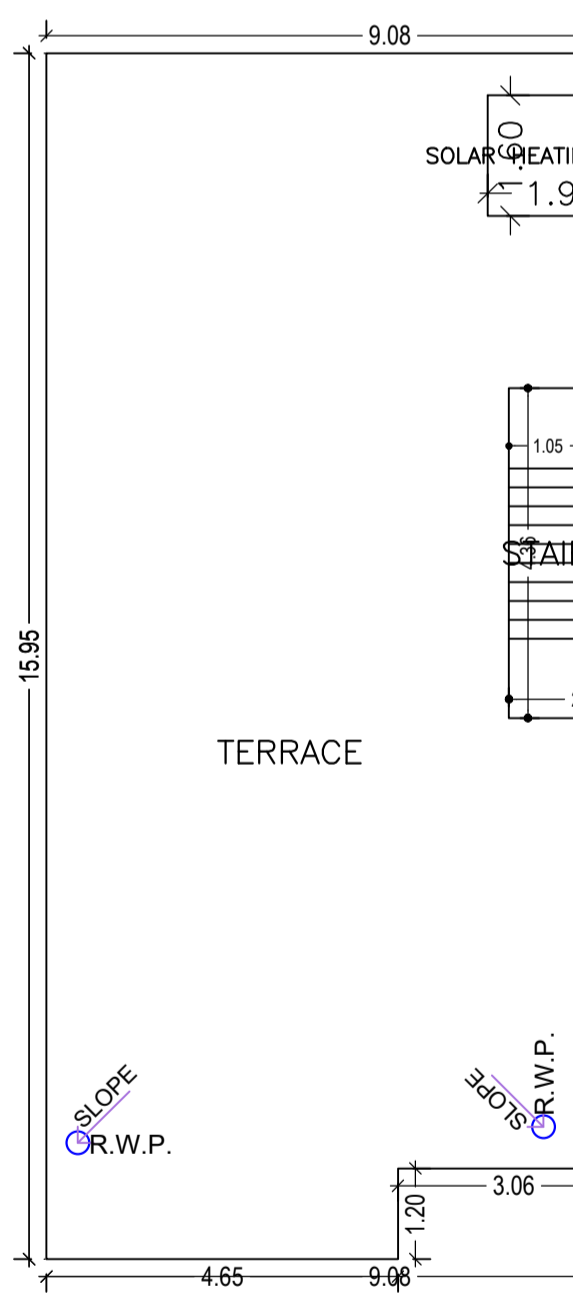
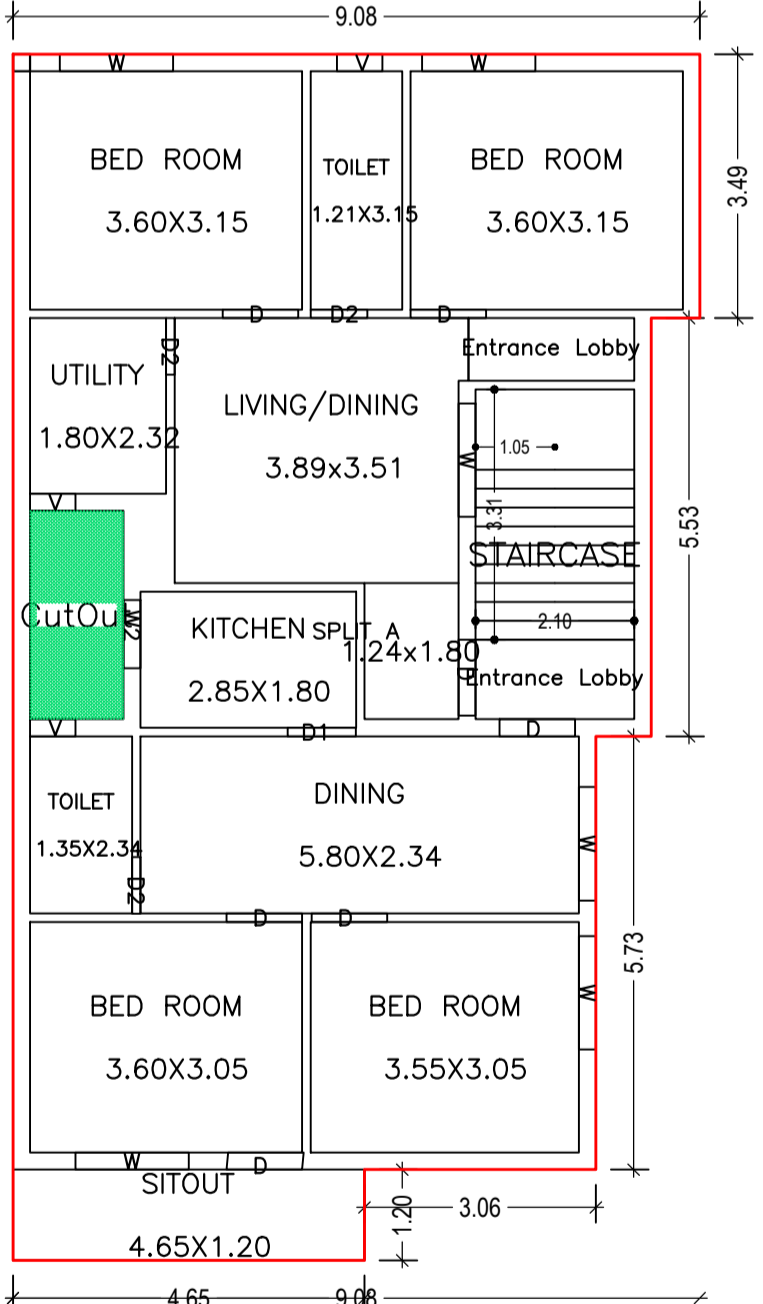
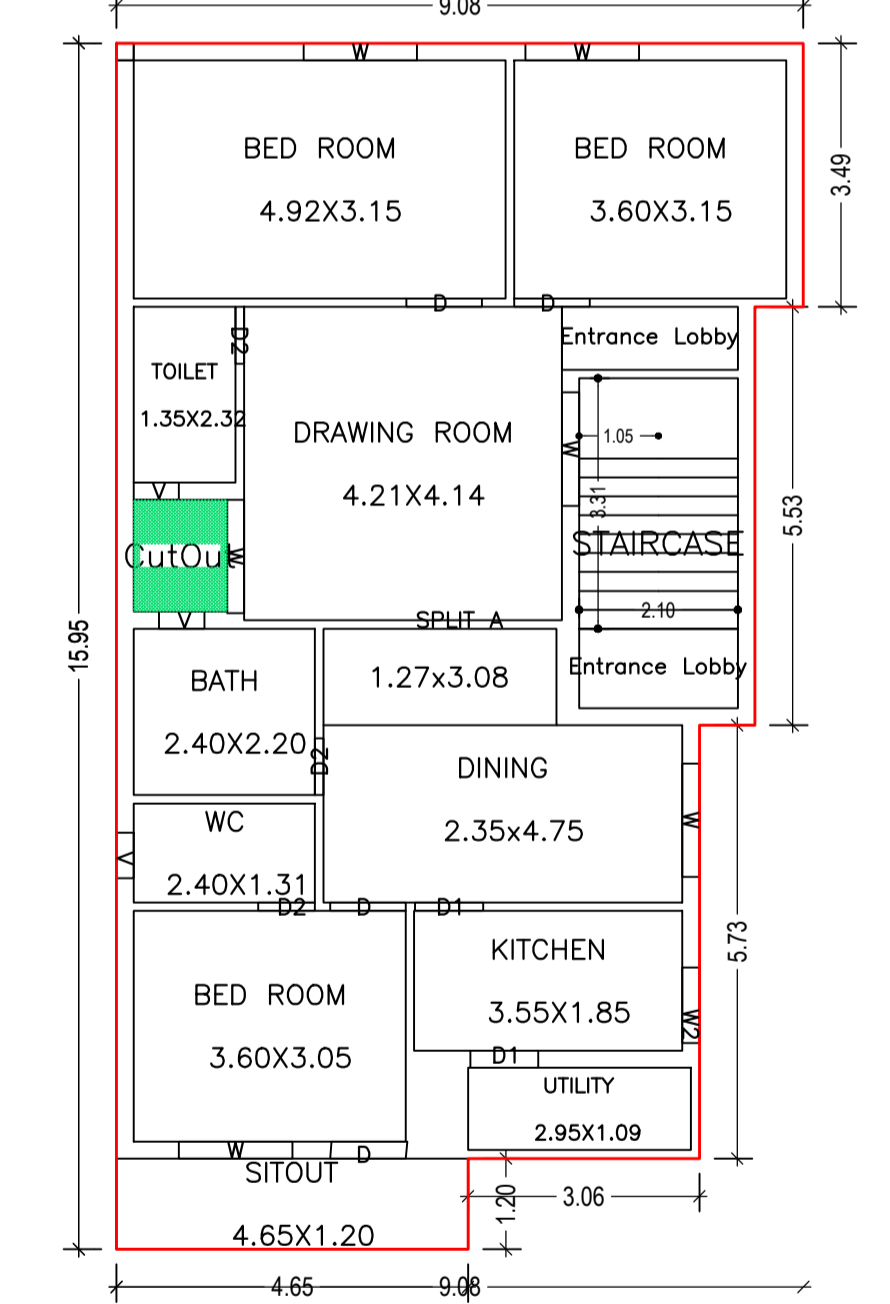
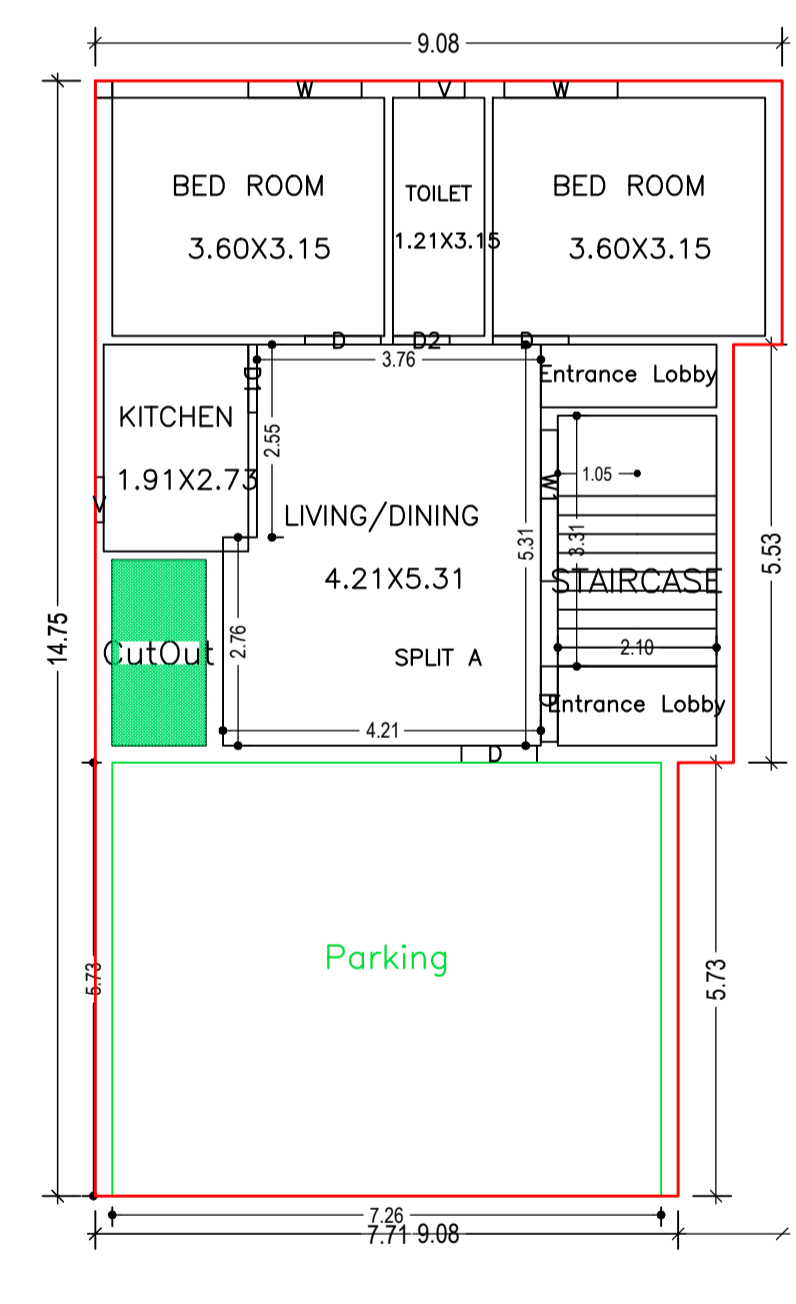
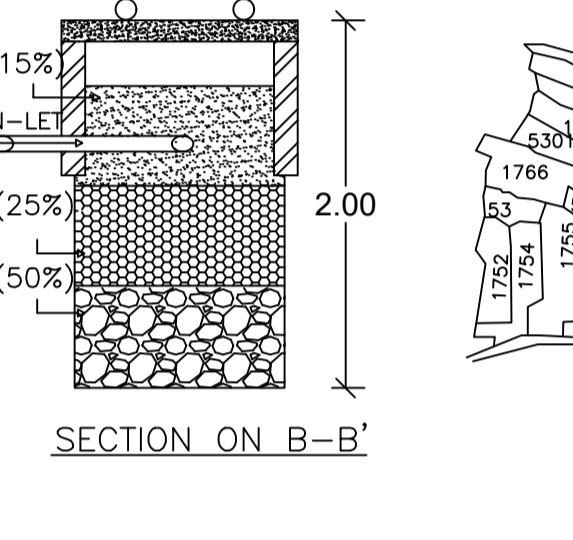
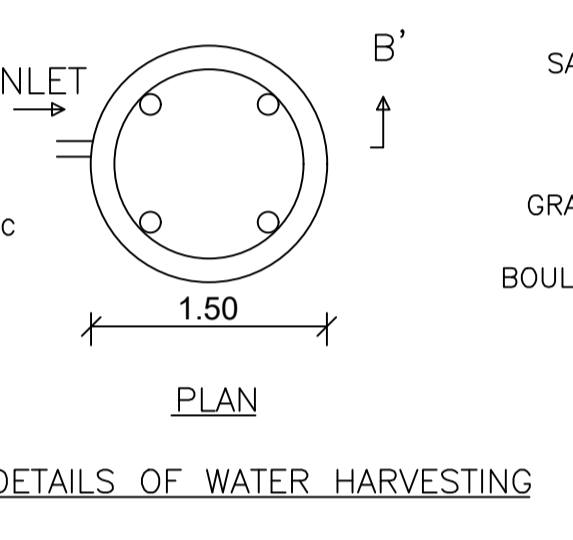
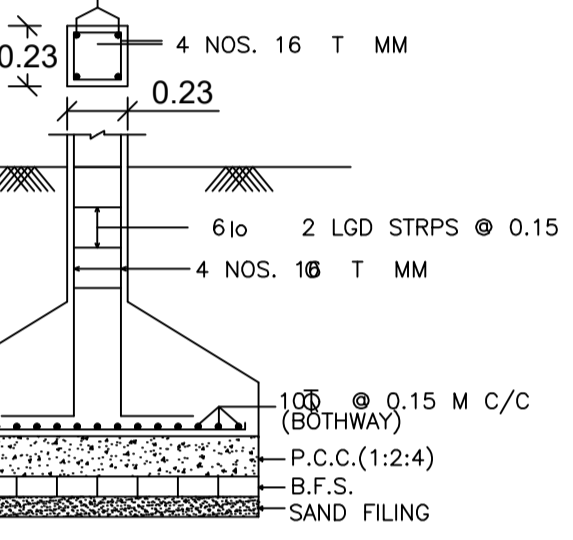
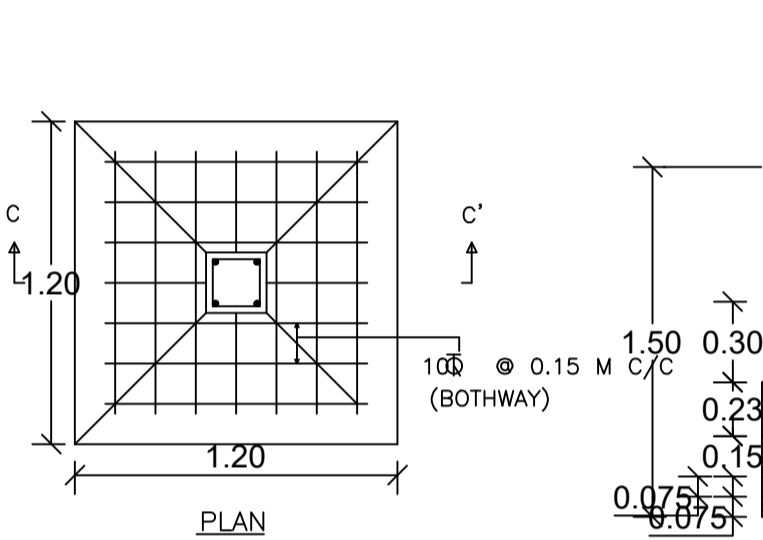
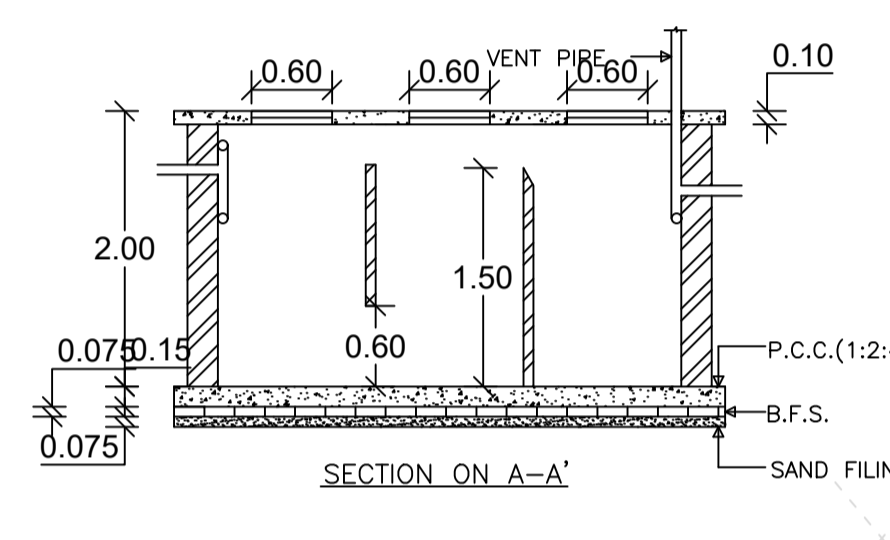
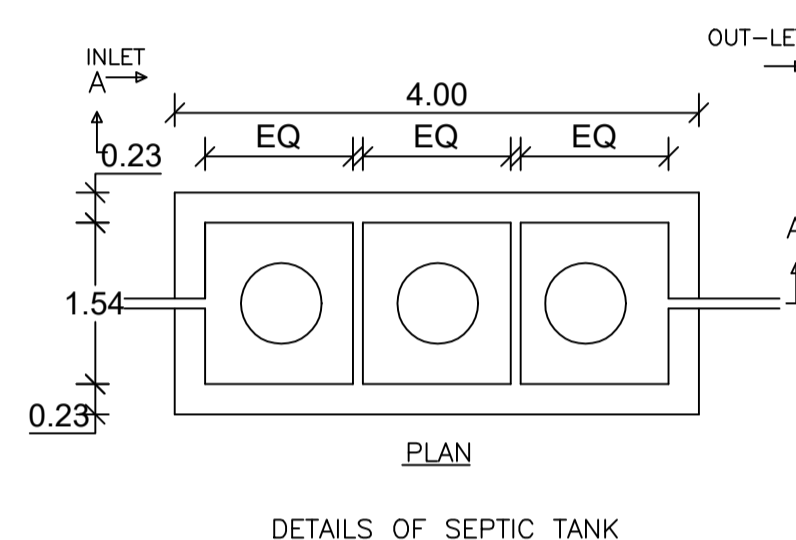

SCHEDULE OF DOOR:

BUILDING NAME	NAME	LENGTH	HEIGHT	NOS
A (MONITA)	D2	0.75	2.10	07
A (MONITA)	D1	0.90	2.10	04
A (MONITA)	D	1.00	2.10	15

SCHEDULE OF WINDOW/VENTILATION:

BUILDING NAME	NAME	LENGTH	HEIGHT	NOS
A (MONITA)	V	0.60	1.20	08
A (MONITA)	W2	0.90	1.20	01
A (MONITA)	W2	1.00	1.20	01
A (MONITA)	W	1.50	1.20	14
A (MONITA)	W1	2.00	1.20	01

Building :A (MONITA)

Floor Name	Gross Builtup Area (Sq.mt)	Deductions From Gross BUA/Area in (Sq.mt)	Total Built Up Area (Sq.mt)	Proposed FAR Area (Sq.mt)	Total FAR Area (Sq.mt)	Total Consumed Additional FAR Area (Sq.mt)	Trmt (No.)
Ground Floor	122.57	3.04	119.53	4.13	115.40	115.40	01
First Floor	128.15	1.83	126.32	4.13	122.19	122.19	00
Second Floor	128.16	3.41	124.75	4.08	120.72	120.72	00
Terrace Floor	0.00	0.00	0.00	0.00	0.00	0.00	00
Total	378.88	8.28	370.60	12.29	358.31	358.31	01

Building USE/SUBUSE Details

Building Name	Building Use	Building SubUse	Building Structure
A (MONITA)	Residential	Bungalow/ Dwelling / Non Apartment	Non-Highrise

Buildingwise Floor FAR Details

Floor Name	Proposed Built Up Area (Sq.mt)	Proposed FAR Area (Sq.mt)	Total Proposed Built Up Area (Sq.mt)	Total FAR Area (Sq.mt)
Ground Floor	119.53	115.40	119.53	115.40
First Floor	126.32	122.19	126.32	122.19
Second Floor	124.75	120.72	124.75	120.72
Terrace Floor	0.00	0.00	0.00	0.00
Total	370.60	358.31	370.60	358.31

FAR & Tenement Details (Table 4c-1)

Building	No. of Same Bldg	Gross Built Up Area (Sq.mt)	Deductions From Gross BUA/Area in (Sq.mt)	Total Built Up Area (Sq.mt)	Deductions (Area in Sq.mt)	Proposed FAR Area (Sq.mt)	Total FAR Area (Sq.mt)	Total Consumed Additional FAR Area (Sq.mt)	Trmt (No.)
A (MONITA)	1	378.88	8.28	370.60	12.29	358.31	358.31	358.31	01
Total	1	378.88	8.28	370.60	12.29	358.31	358.31	358.31	01

UnitBUA Table for Building :A (MONITA)

FLOOR	Name	UnitBUA Type	UnitBUA Area	Carpel Area	No. of Rooms	No. of Tenement
GROUND FLOOR PLAN	SPLIT A	FLAT	370.61	370.46	5	1
FIRST FLOOR PLAN	SPLIT A	FLAT	0.00	0.00	11	0
SECOND FLOOR PLAN	SPLIT A	FLAT	0.00	0.00	11	0
Total	-	-	370.61	370.46	27	1

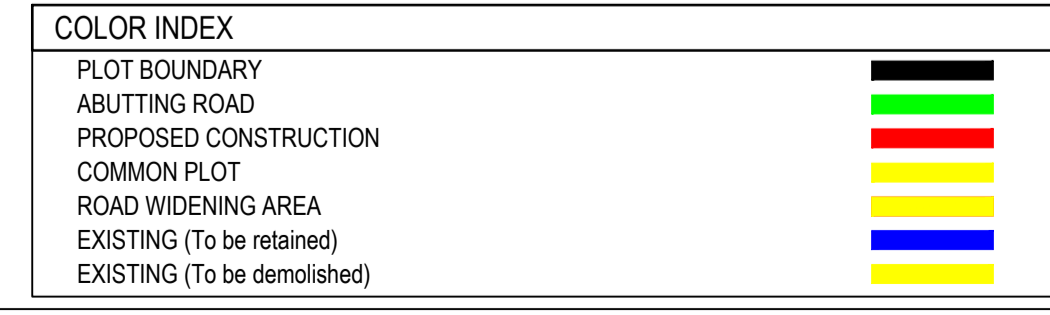

LTP NAME AND SIGNATURE	STRUCTURAL ENG'S NAME AND SIGNATURE	BUILDER NAME AND SIGNATURE	DIGITAL SIGNATURE
DINABANDHU RAJAK CMC/ENG/001/2020			