

Proposal Basic Information

Proposal File No.	CMC/BI/0266/W07/2023
Owner Name	HEMA PRAMANIK
Khata No	615,617,609
Plot No	3151,3150,3070
Village Name	Chas
Use	Residential
SubUse	Bungalow/ Dwelling / Non Apartment

AREA STATEMENT CHAS MUNICIPAL CORPORATION	VERSION NO.: 1.0.66
	VERSION DATE: 16/10/2020

PROJECT DETAIL:	Plot Use: Residential
Region: JHARKHAND URBAN LOCAL BODIES	Plot SubUse: Bungalow/ Dwelling / Non Apartment
District: BOKARO	PlotNearbyReligiousStructure: NA
Authority: CHAS MUNICIPAL CORPORATION	PlotSubPlot No: 3151,3150,3070
Inward No: CMC/BI/0266/W07/2023	North: Plot No. - PART PLOT NO. - 3150 & 3070
Application Type: General Proposal	South: Plot No. - PART PLOT NO. - 3150,3070
Project Type: Building Permission	East: Road Width - 7.31 MTR WIDE ROAD
Nature of Development: New	West: Plot No. - PLOT NO. - 3150
Location of Development Area: Old Area	

AREA DETAILS:		SQ.MT.
AREA OF PLOT (Minimum)	(A)	165.73
NET AREA OF PLOT(Gross Plot Area - Deduction from Gross Plot area)	(A-Deductions)	165.73
Deduction for Balance Plot Area(from Gross Plot Area)		
Common Plot		8.97
Total		8.97

BALANCE AREA OF PLOT(Net Plot Area - Recreational/Amenity space)	(A-Deductions)	156.76
PLOT AREA FOR COVERAGE(Net Plot Area)	(A-Deductions)	165.73
Plot Area for FAR (Net Plot Area + Road/Widening Area)	(A-Deductions)	165.73

COVERAGE CHECK		
Permissible Coverage area (70.00 %)		116.01
Proposed Coverage Area (62.03 %)		102.80
Total Prop. Coverage Area (62.03 %)		102.80
Balance coverage area (7.97 %)		13.21

FAR CHECK		
Perm. FAR Area (2.500)		414.32
Total Perm. FAR area		414.32
Residential FAR		340.70
Proposed FAR Area		340.70
Total Proposed FAR Area		340.70
Consumed FAR (Factor)		2.06
Balance FAR Area		73.62

BUILT UP AREA CHECK		
Total Proposed BuiltUp Area		340.70

ARCHITECT (Regd)	DINABANDHU RAJAK
ENGINEER (Regd)	
SUPERVISOR (Regd)	HEMA PRAMANIK
OWNER (Regd)	

DEVELOPMENT AUTHORITY	LOCAL BODY
-----------------------	------------

Building :A (HEMA)		
--------------------	--	--

Floor Name	Total Built Up Area (Sq.mt.)	Proposed FAR Area (Sq.mt.) Res.	Total FAR Area (Sq.mt.)	Total Consumed Additional FAR Area (Sq.mt.)	Trmt (No.)
------------	------------------------------	---------------------------------	-------------------------	---	------------

Ground Floor	102.80	102.80	102.80	102.80	01
First Floor	118.95	118.95	118.95	118.95	00
Second Floor	118.95	118.95	118.95	118.95	00
Terrace Floor	0.00	0.00	0.00	0.00	00
Total :	340.70	340.70	340.70	340.70	01

Total Number of Same Buildings :	1	340.70	340.70	340.70	01
Total :	340.70	340.70	340.70	340.70	01

SCHEDULE OF DOOR:					
-------------------	--	--	--	--	--

BUILDING NAME	NAME	LENGTH	HEIGHT	NOS
---------------	------	--------	--------	-----

A (HEMA)	D2	0.75	2.10	13
A (HEMA)	D1	0.85	2.10	03
A (HEMA)	D1	0.90	2.10	04
A (HEMA)	D	1.00	2.10	09

SCHEDULE OF WINDOW/VENTILATION:					
---------------------------------	--	--	--	--	--

BUILDING NAME	NAME	LENGTH	HEIGHT	NOS
---------------	------	--------	--------	-----

A (HEMA)	V	0.60	0.60	11
A (HEMA)	W2	0.90	1.20	06
A (HEMA)	W	1.00	1.20	09
A (HEMA)	W1	1.30	1.20	02
A (HEMA)	GLASS WIN	2.44	2.40	02

Building USE/SUBUSE Details					
-----------------------------	--	--	--	--	--

Building Name	Building Use	Building SubUse	Building Structure
---------------	--------------	-----------------	--------------------

A (HEMA)	Residential	Bungalow/ Dwelling / Non Apartment	Non-Highrise
----------	-------------	------------------------------------	--------------

Structural Eng's Name and Signature	Builder Name and Signature	Digital Signature
-------------------------------------	----------------------------	-------------------

DINABANDHU RAJAK		CMC/ENG/001/2020
------------------	--	------------------

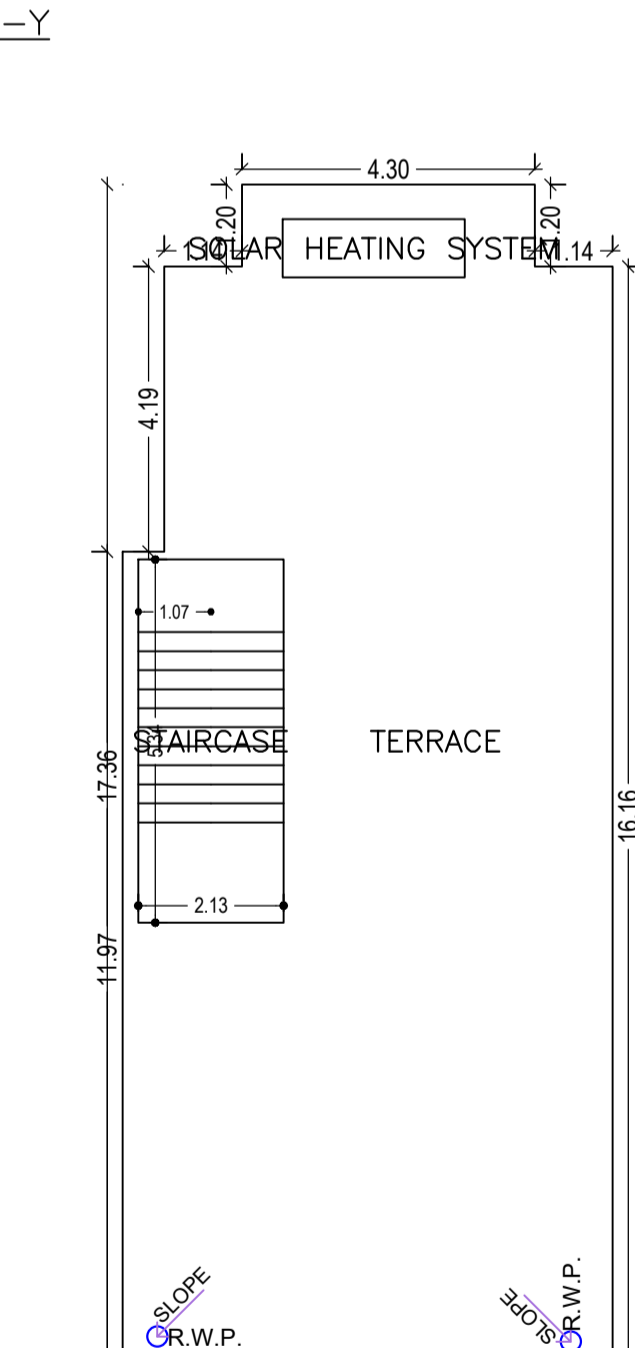
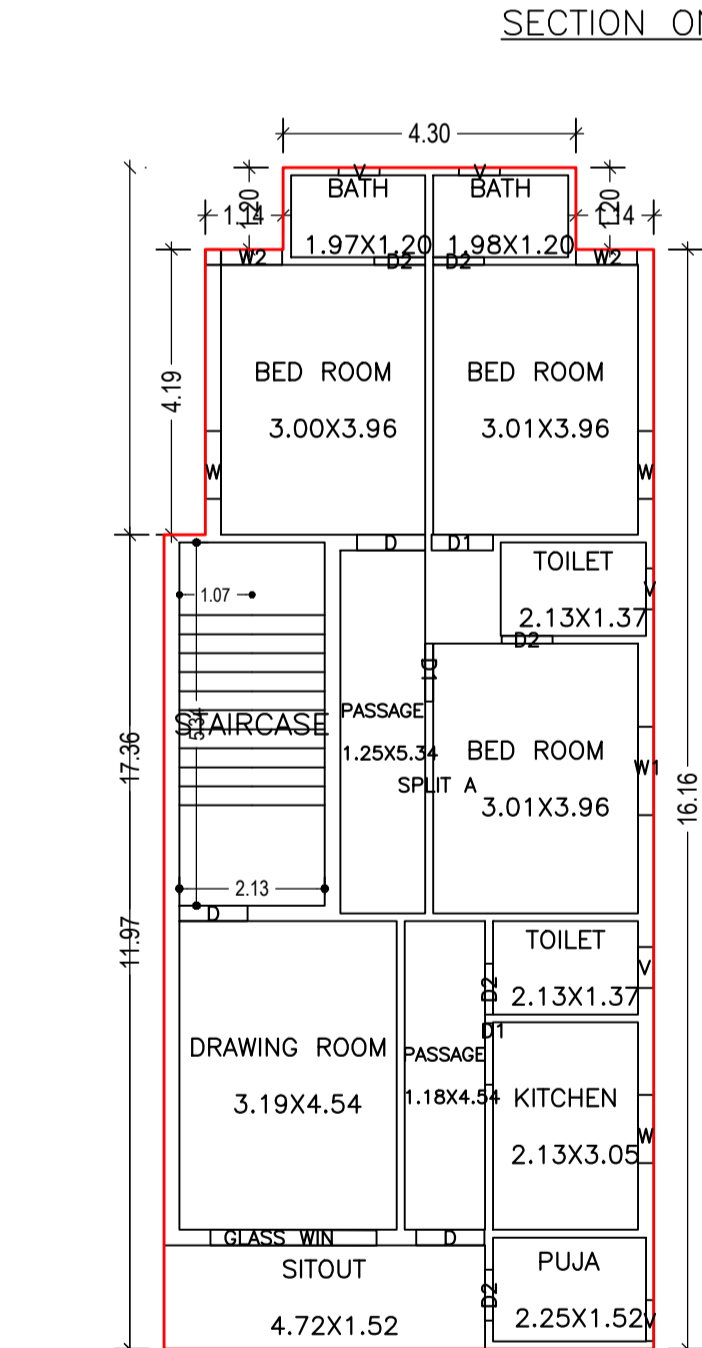
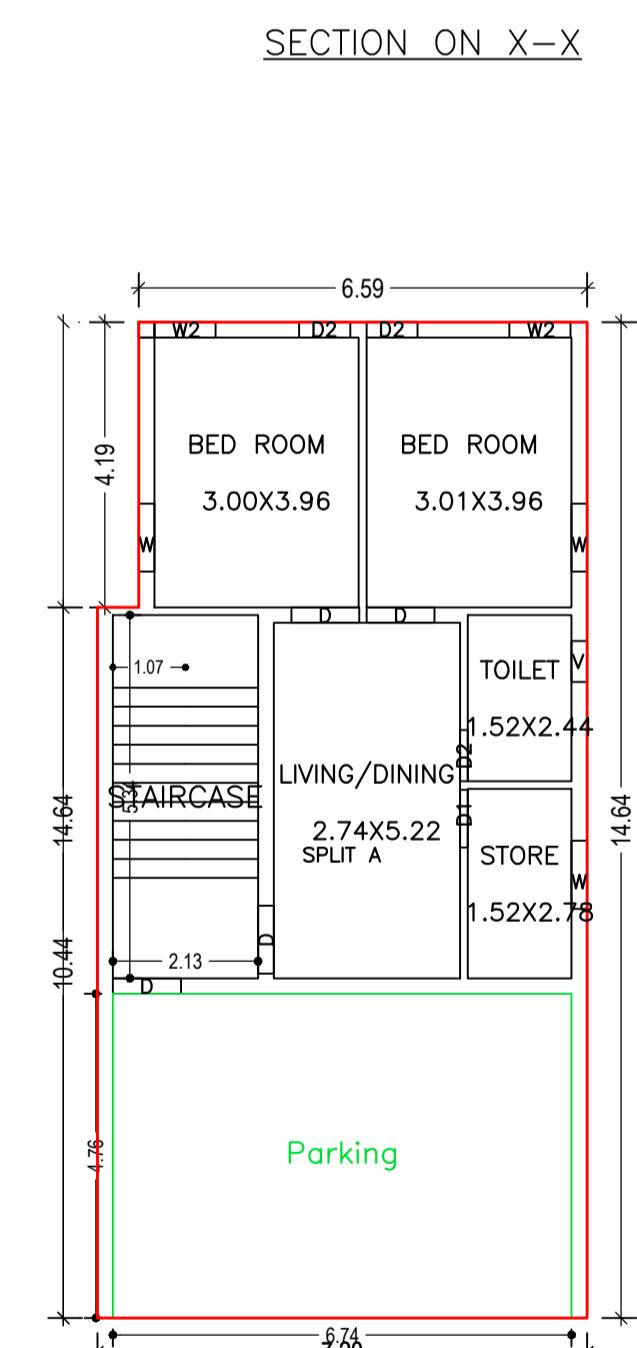
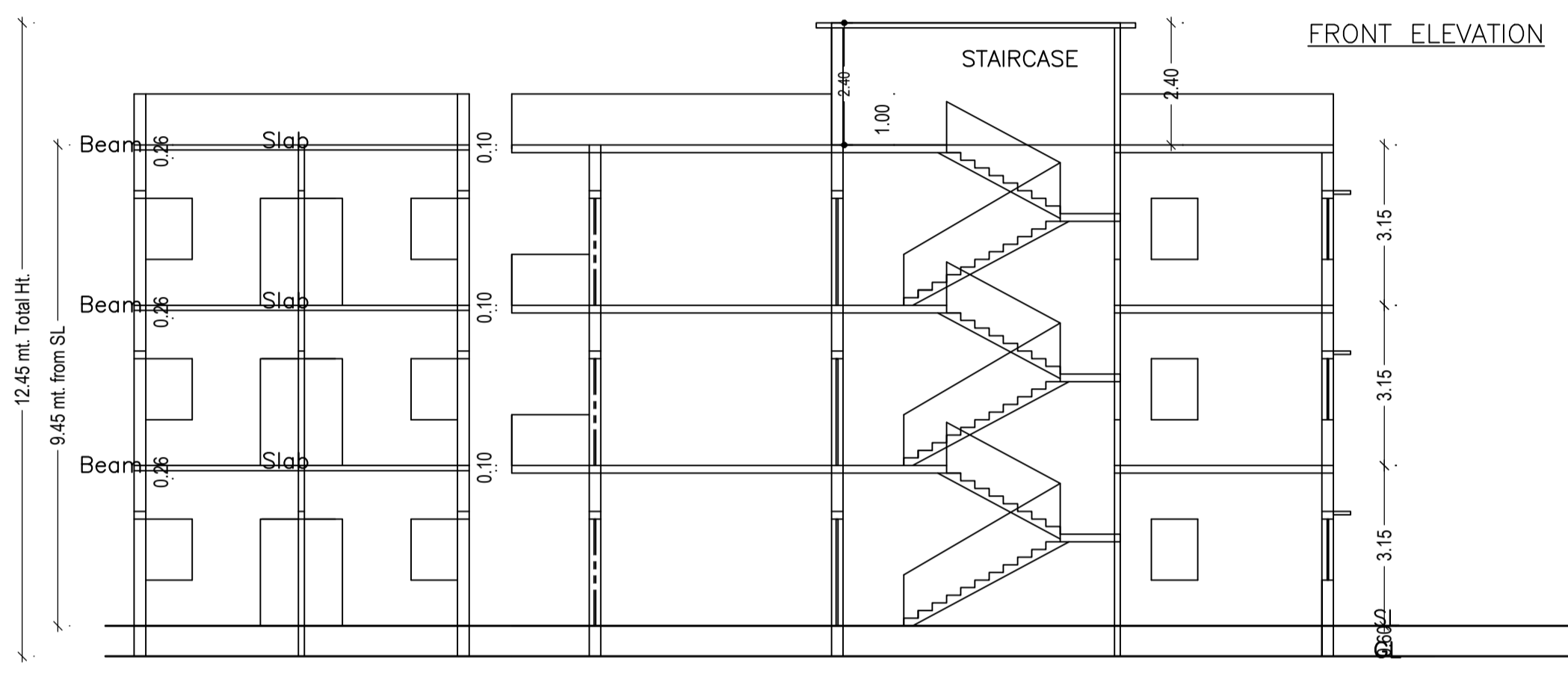
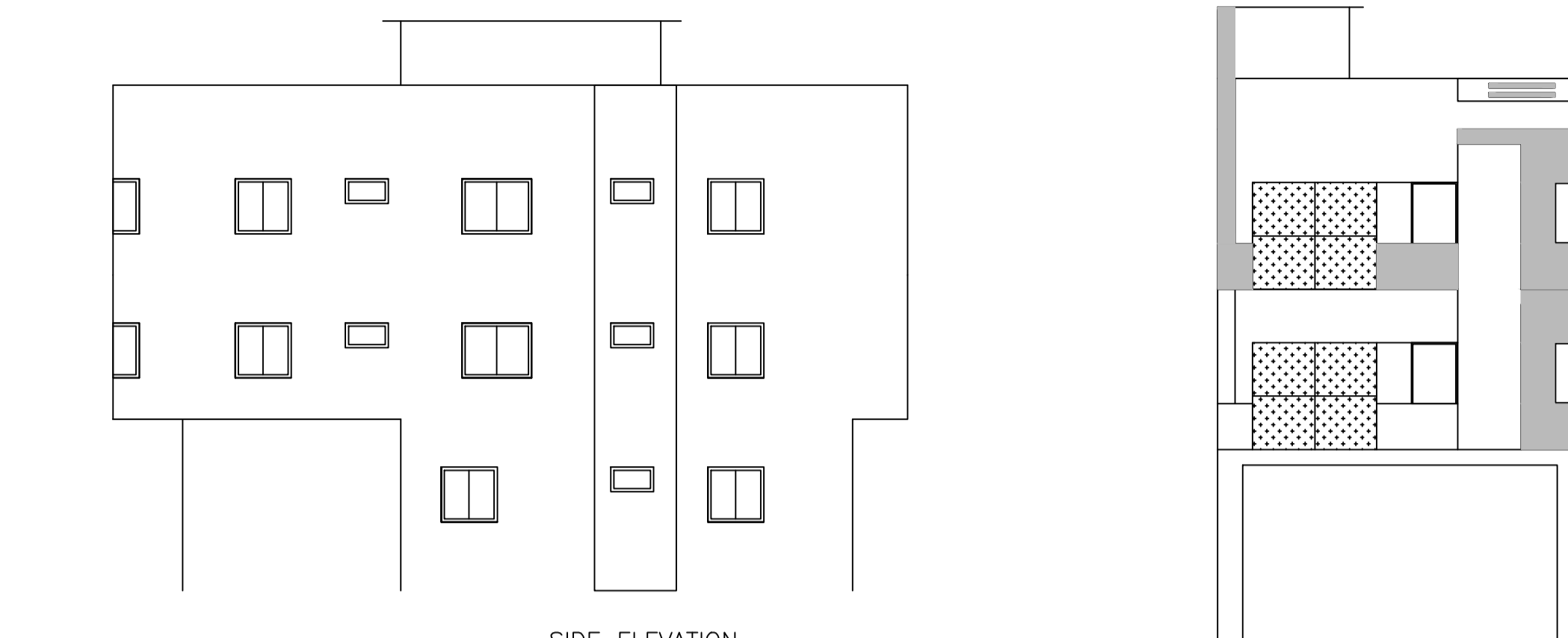

GROUND FLOOR PLAN (Proposed) (SCALE 1:100)

UnitBUA Table for Building :A (HEMA)

FLOOR	Name	UnitBUA Type	UnitBUA Area	Carpet Area	No. of Rooms	No. of Tenement
GROUND FLOOR PLAN	SPLIT A	FLAT	340.70	340.54	5	1
TYPICAL - 1 & 2 FLOOR PLAN	SPLIT A	FLAT	0.00	0.00	13	0
Total:	-	-	340.70	340.54	31	1

TYPICAL - 1& 2 FLOOR PLAN (Proposed) (SCALE 1:100)

FAR & Tenement Details (Table 4c-1)

Building	No. of Same Bldg	Total Built Up Area (Sq.mt.)	Proposed FAR Area (Sq.mt.) Res.	Total FAR Area (Sq.mt.)	Total Consumed Additional FAR Area (Sq.mt.)	Trmt (No.)
A (HEMA)	1	340.70	340.70	340.70	340.70	01
Grand Total :	1	340.70	340.70	340.70	340.70	01

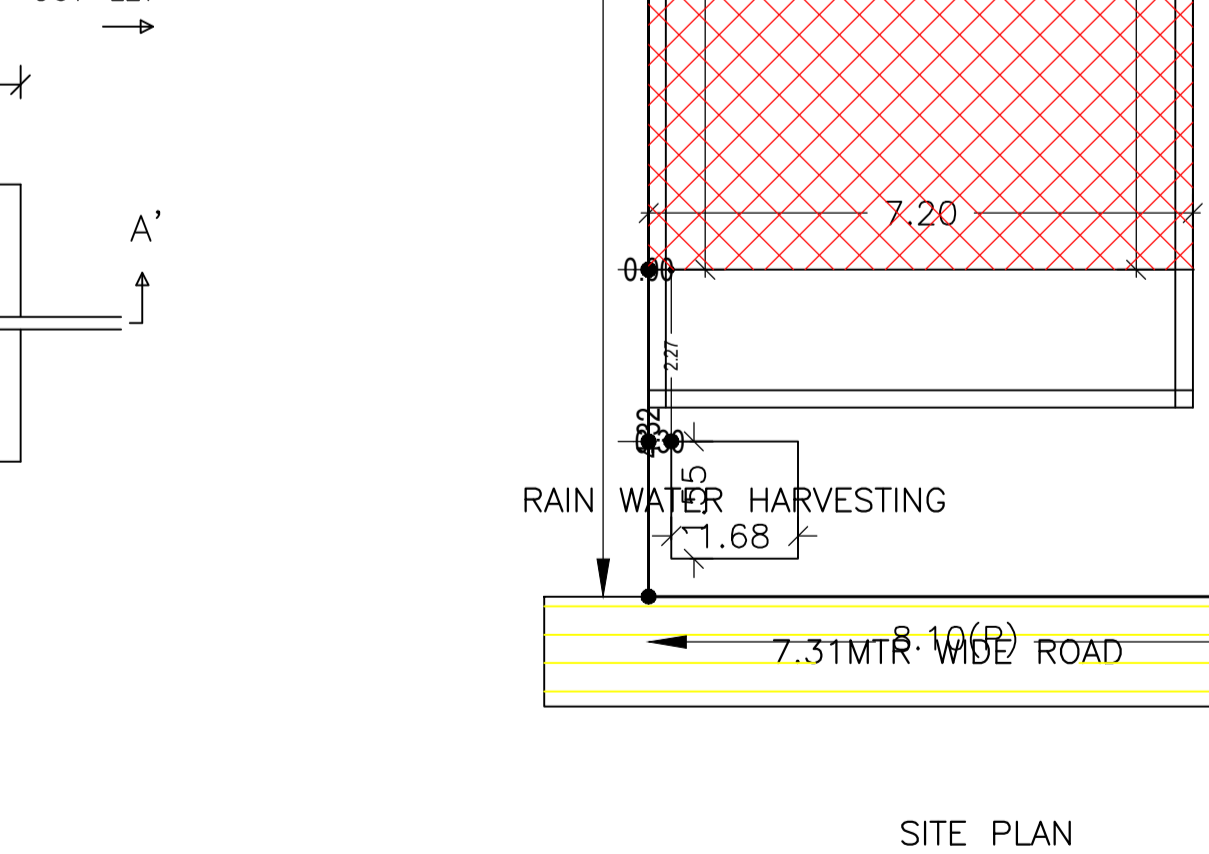
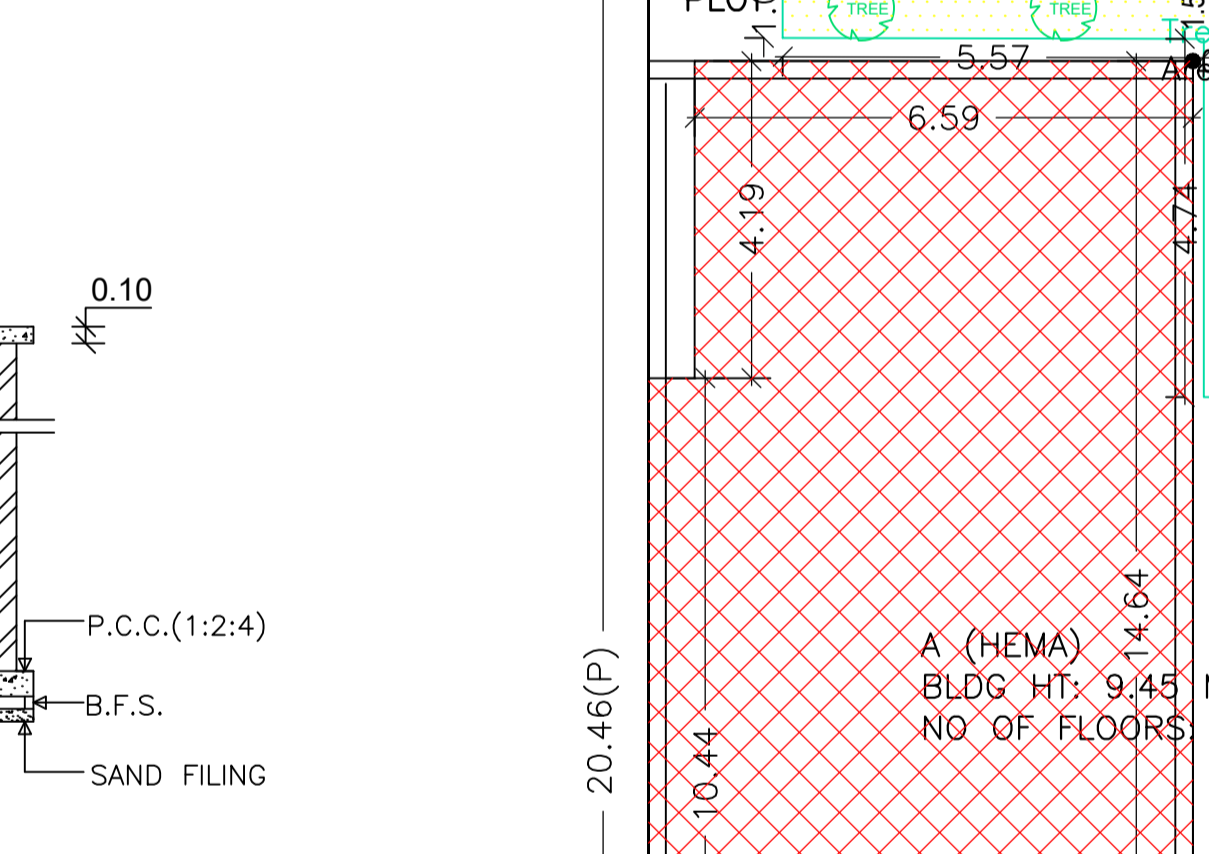
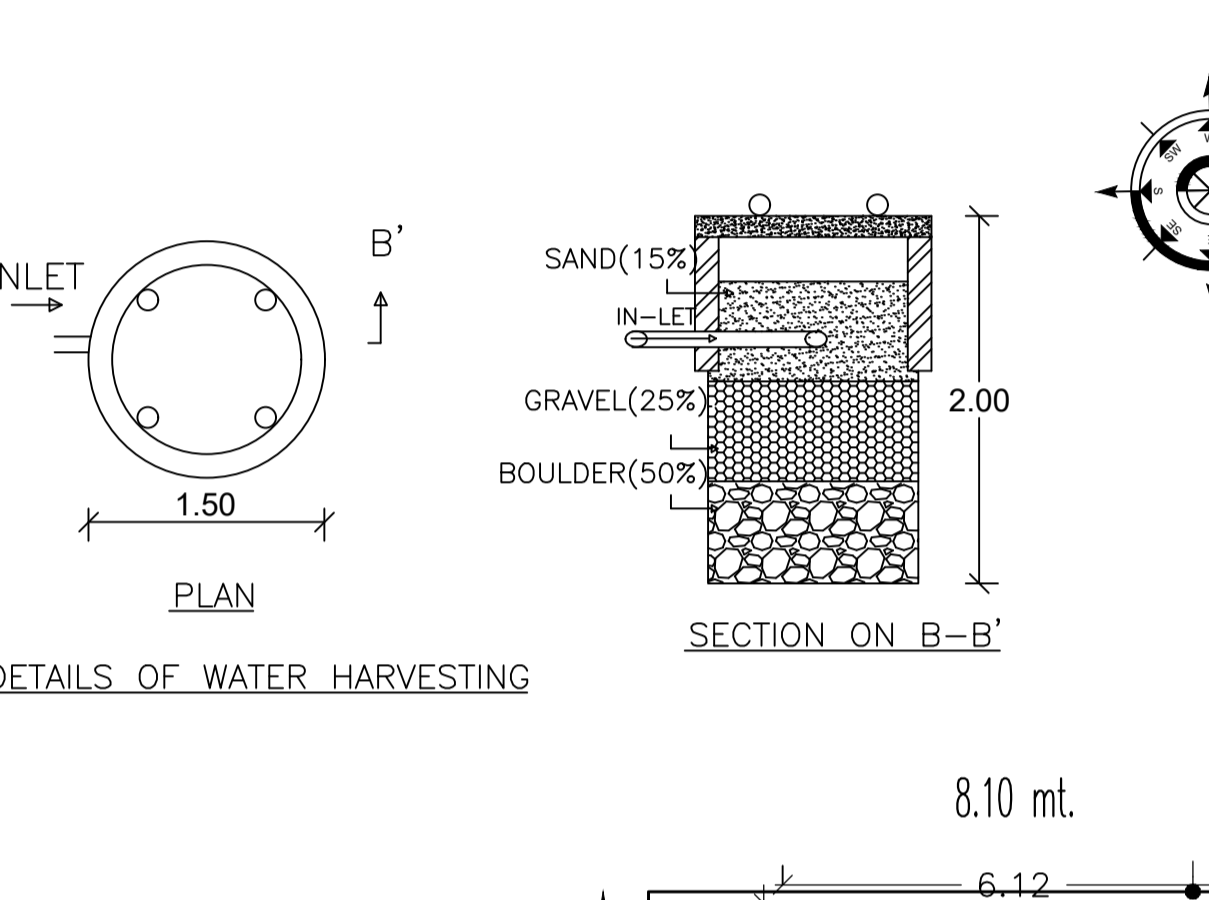
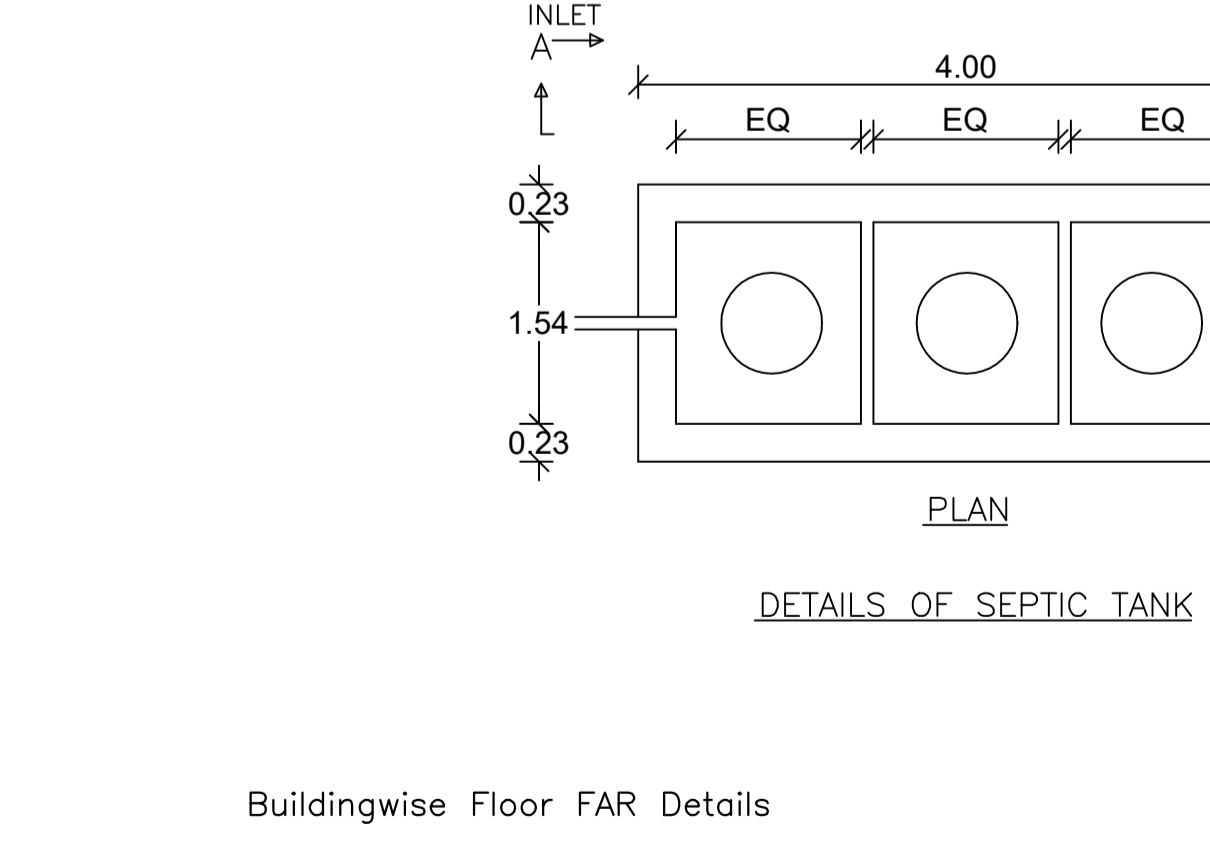
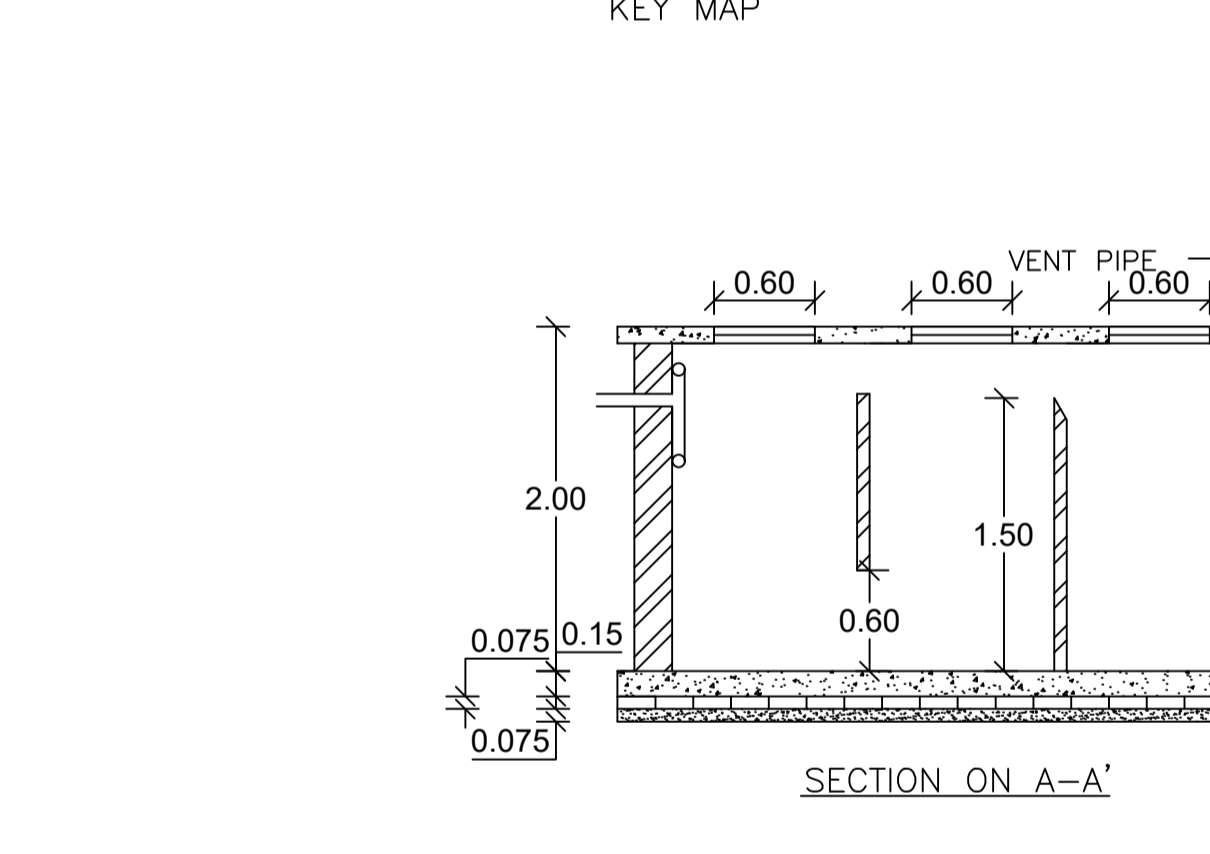
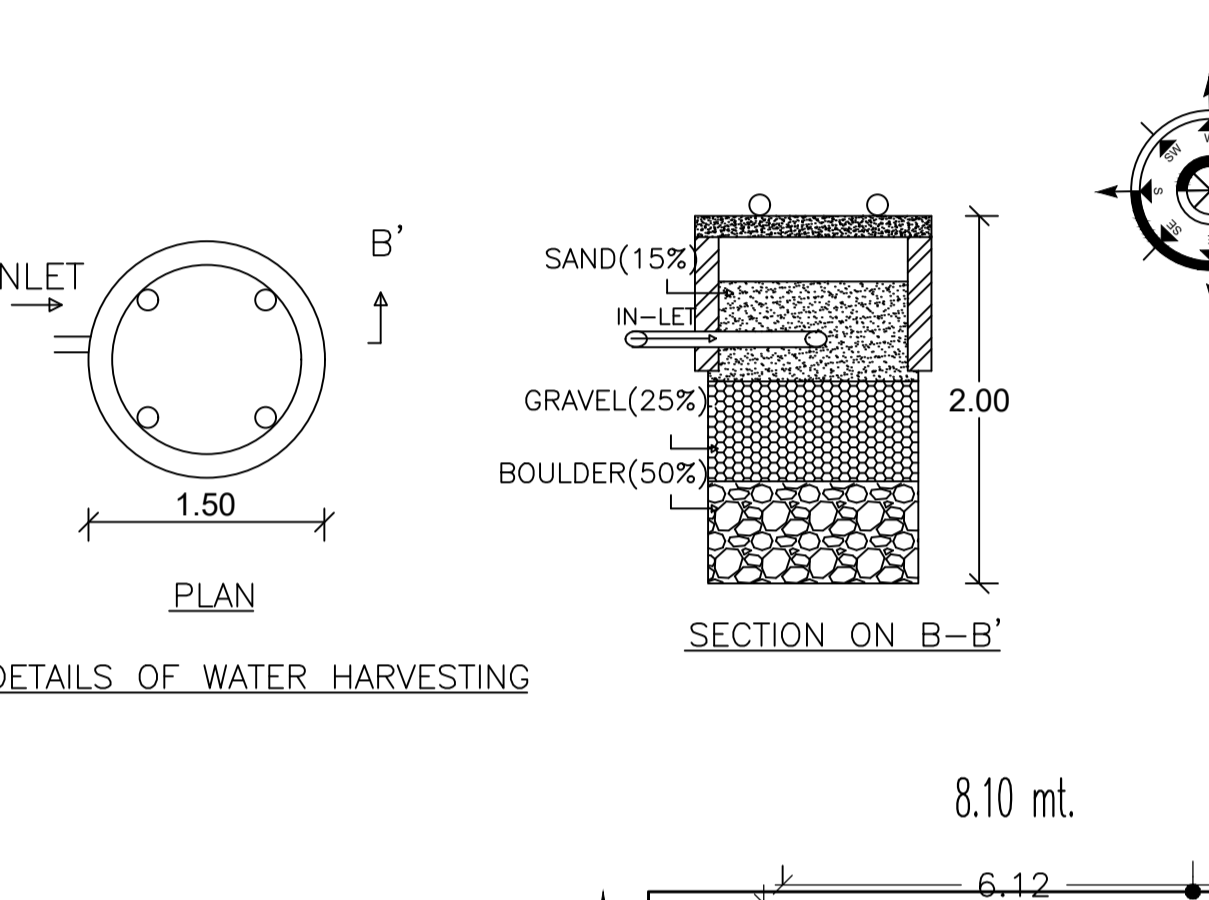
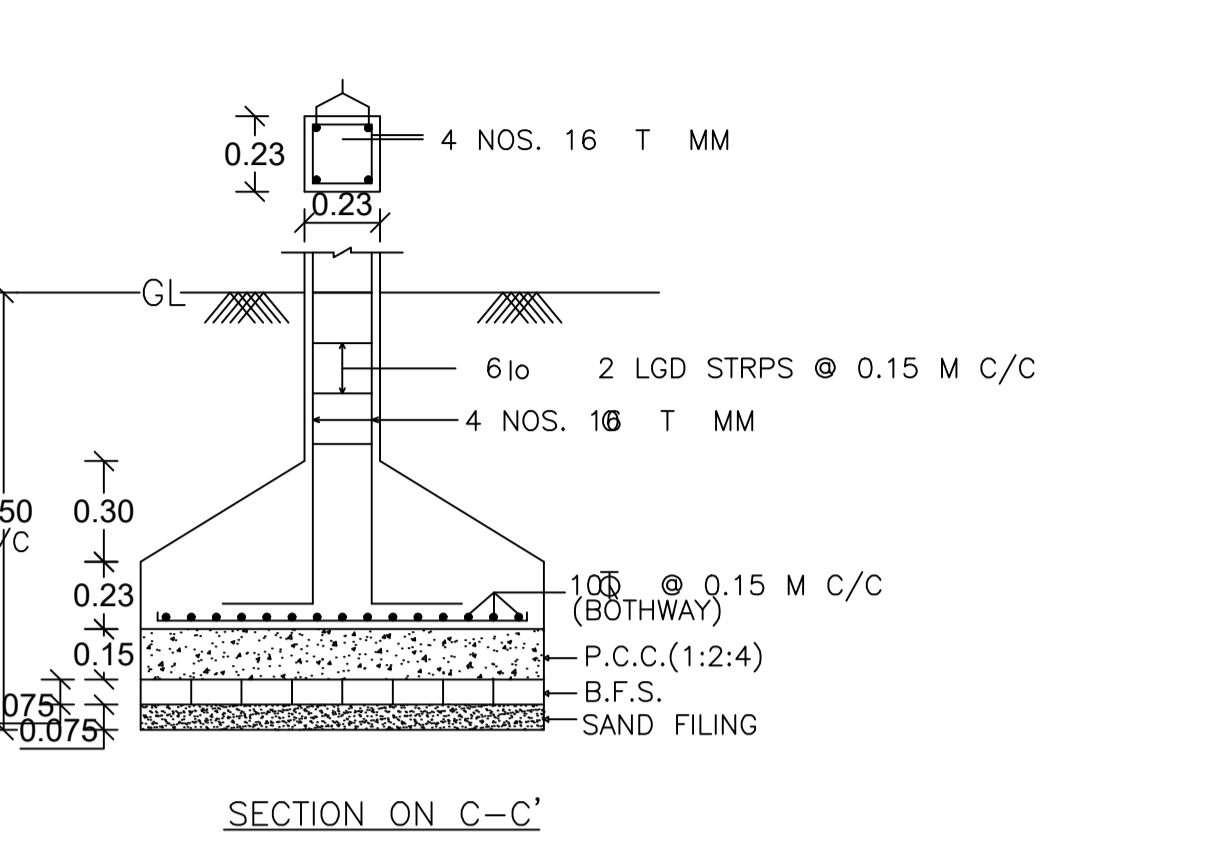
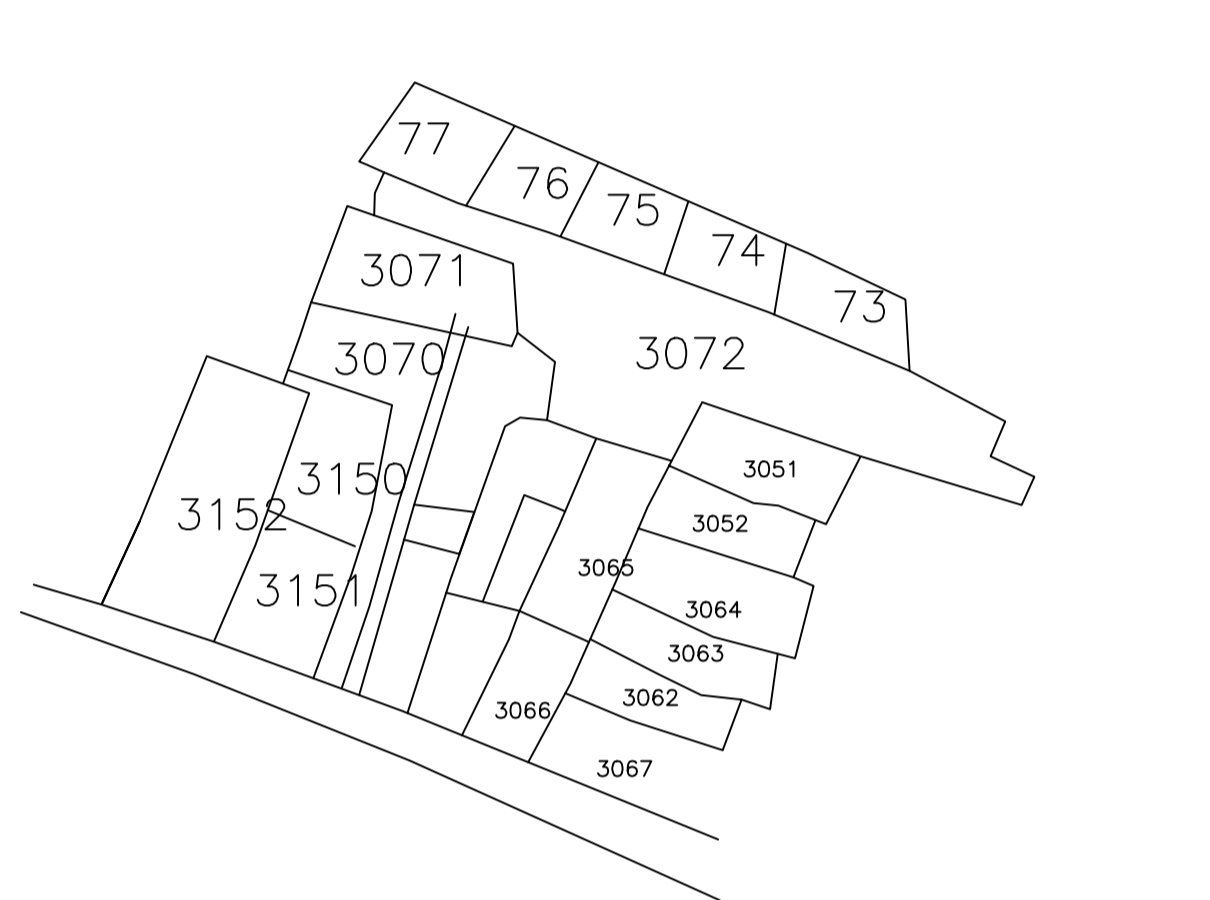
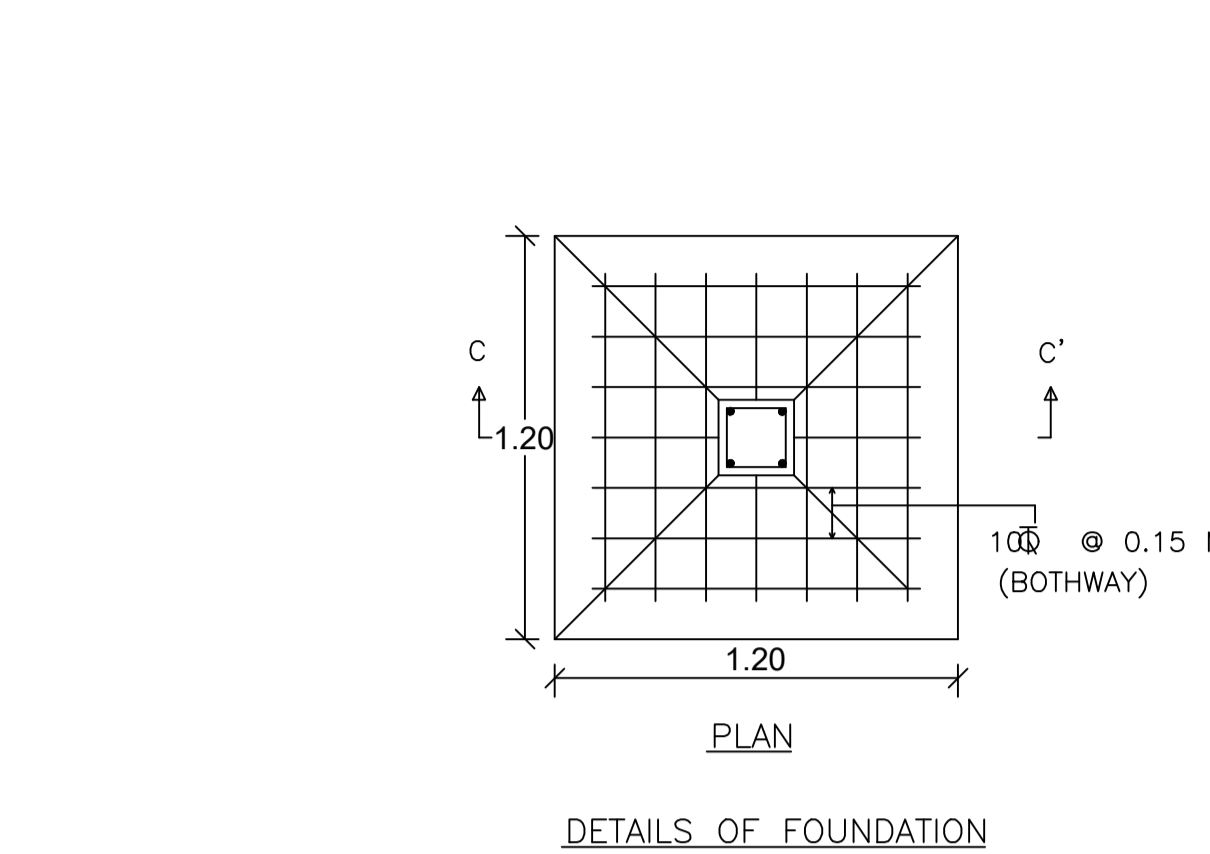
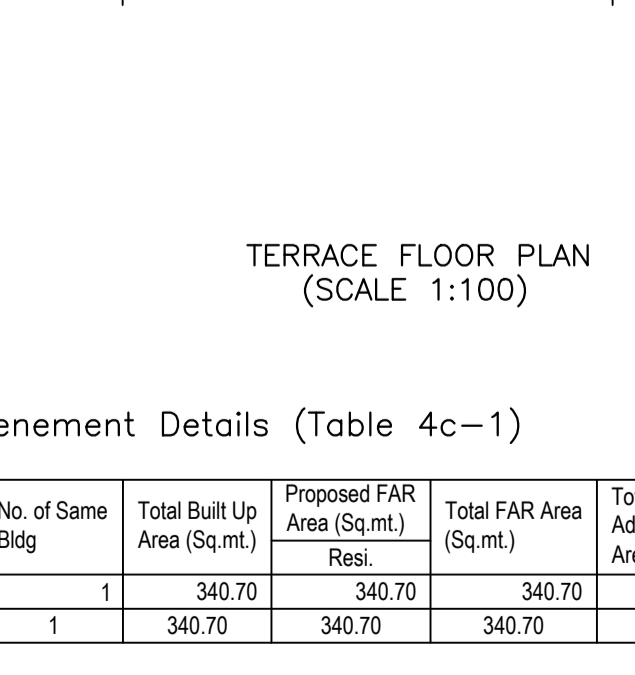

COLOR INDEX

PLOT BOUNDARY	Black
ABUTTING ROAD	Red
PROPOSED CONSTRUCTION	Green
COMMON PLOT	Blue
ROAD WIDENING AREA	Yellow
EXISTING (To be retained)	White
EXISTING (To be demolished)	Grey

