

Proposal Basic Information

Proposal File No.	CMC/BP/0271/W02/2023
Owner Name	SHAIL JHA
Khata No	1
Plot No	1274
Village Name	Chas
Use	Residential
SubUse	Bungalow/ Dwelling / Non Apartment

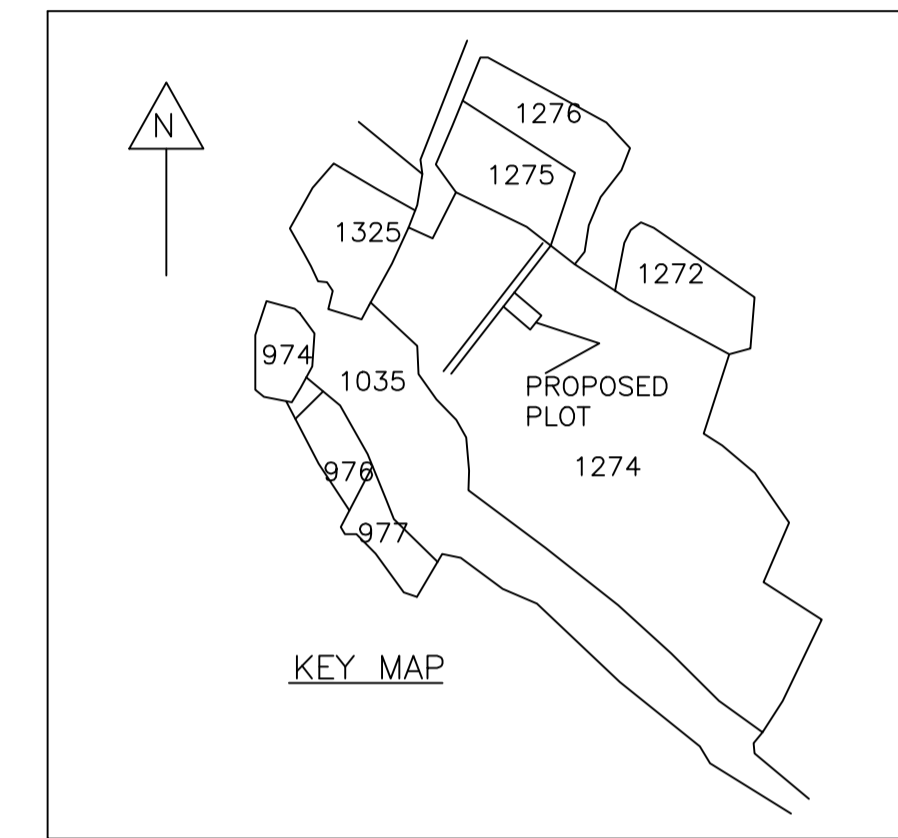

AREA STATEMENT CHAS MUNICIPAL CORPORATION	VERSION NO.: 1.0.66
PROJECT DETAIL:	VERSION DATE: 16/10/2020
Region: JHARKHAND URBAN LOCAL BODIES	Plot Use: Residential
District: BOKARO	Plot SubUse: Bungalow/ Dwelling / Non Apartment
Authority: CHAS MUNICIPAL CORPORATION	PlotNearbyReligiousStructure: NA
Inward No: CMC/BP/0271/W02/2023	PlotSubPlot No: 1274
Application Type: General Proposal	North: Plot No. - PART OF PLOT
Project Type: Building Permission	South: CTS No. - RAJIV KUMAR UPADHYAY
Nature of Development: New	East: CTS No. - BACHANDIH DHAR
Location of Development Area: Old Area	West: Road Width - 6.10 MTR WIDE ROAD
AREA DETAILS:	SQ.MT.
AREA OF PLOT (Minimum)	(A) 111.29
NET AREA OF PLOT(Gross Plot Area - Deduction from Gross Plot area)	(A-Deductions) 111.29
Deduction for Balance Plot Area(from Gross Plot Area)	
Common Plot	6.70
Total	6.70
BALANCE AREA OF PLOT(Net Plot Area - Recreational/Amenity space)	(A-Deductions) 104.59
PLOT AREA FOR COVERAGE(Net Plot Area)	(A-Deductions) 111.29
Plot Area for FAR (Net Plot Area + Road Widening Area)	(A-Deductions) 111.29
COVERAGE CHECK	
Permissible Coverage area ( 70.00 % )	77.90
Proposed Coverage Area ( 47.94 % )	53.36
Total Prop. Coverage Area ( 47.94 % )	53.36
Balance coverage area ( 22.05 % )	24.54
FAR CHECK	
Perm. FAR Area ( 2.500 )	278.23
Total Perm. FAR area	278.23
Residential FAR	106.71
Proposed FAR Area	106.71
Total Proposed FAR Area	106.71
Consumed FAR (Factor)	0.96
Balance FAR Area	171.52
BUILT UP AREA CHECK	
Total Proposed BuiltUp Area	106.72
ARCHITECT (Regd)	AMRIT KUMAR MAHATO
ENGINEER (Regd)	
SUPERVISOR (Regd)	
OWNER (Regd)	SHAIL JHA
DEVELOPMENT AUTHORITY	LOCAL BODY

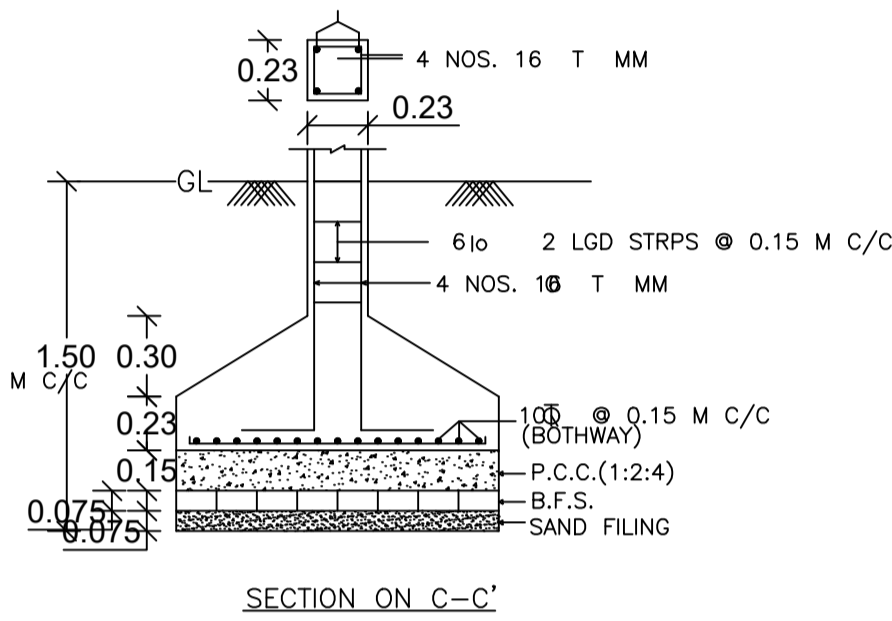
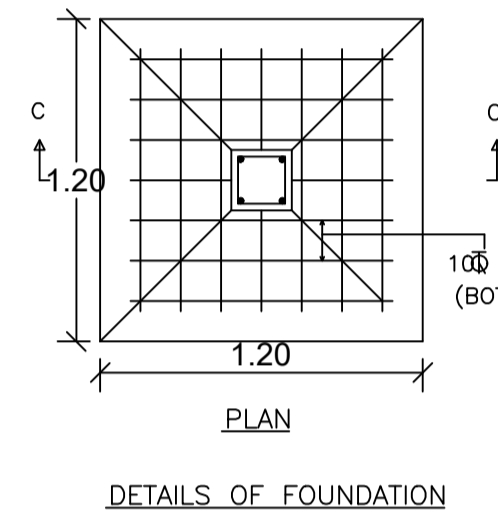
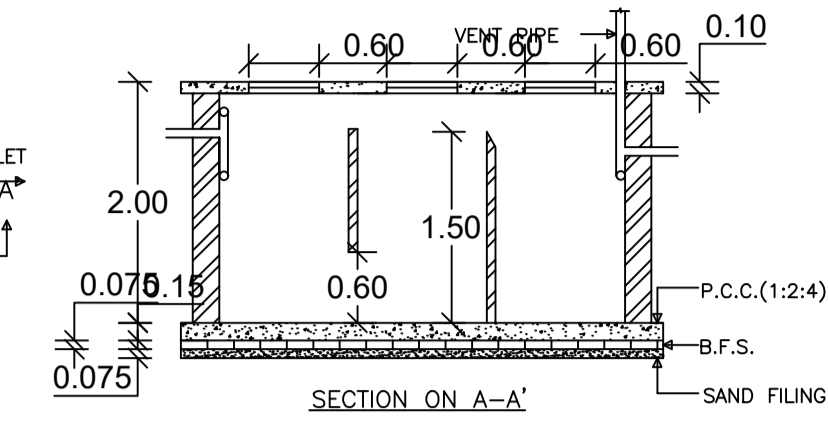
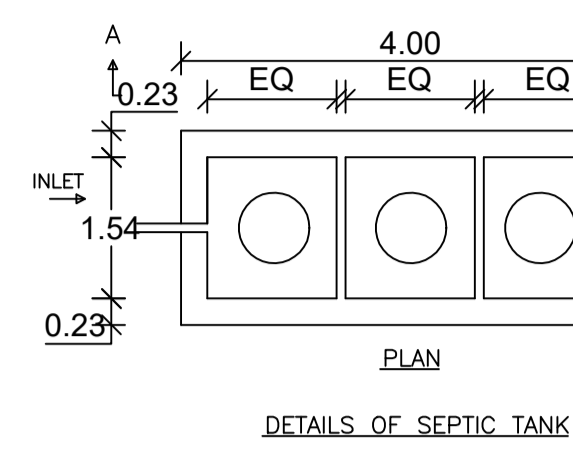
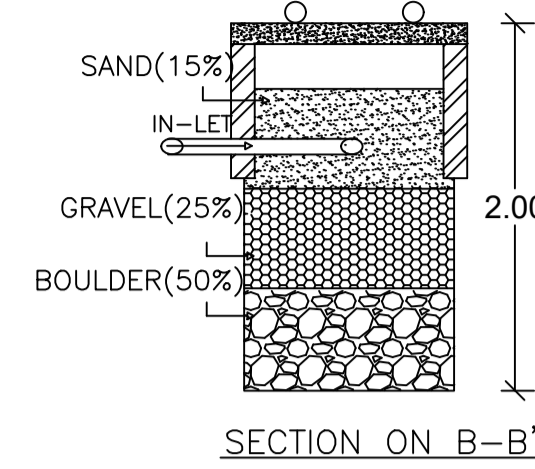
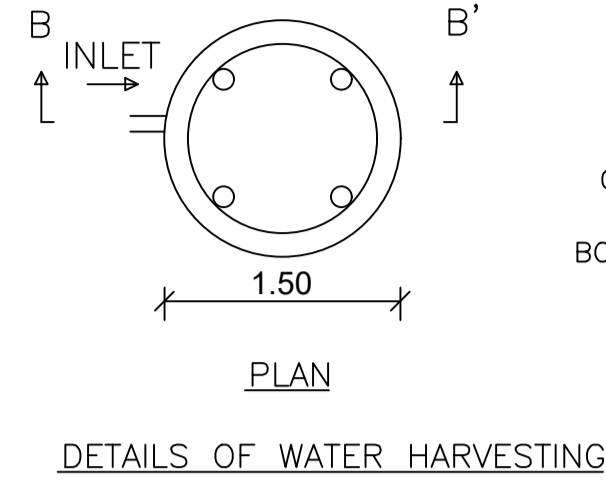
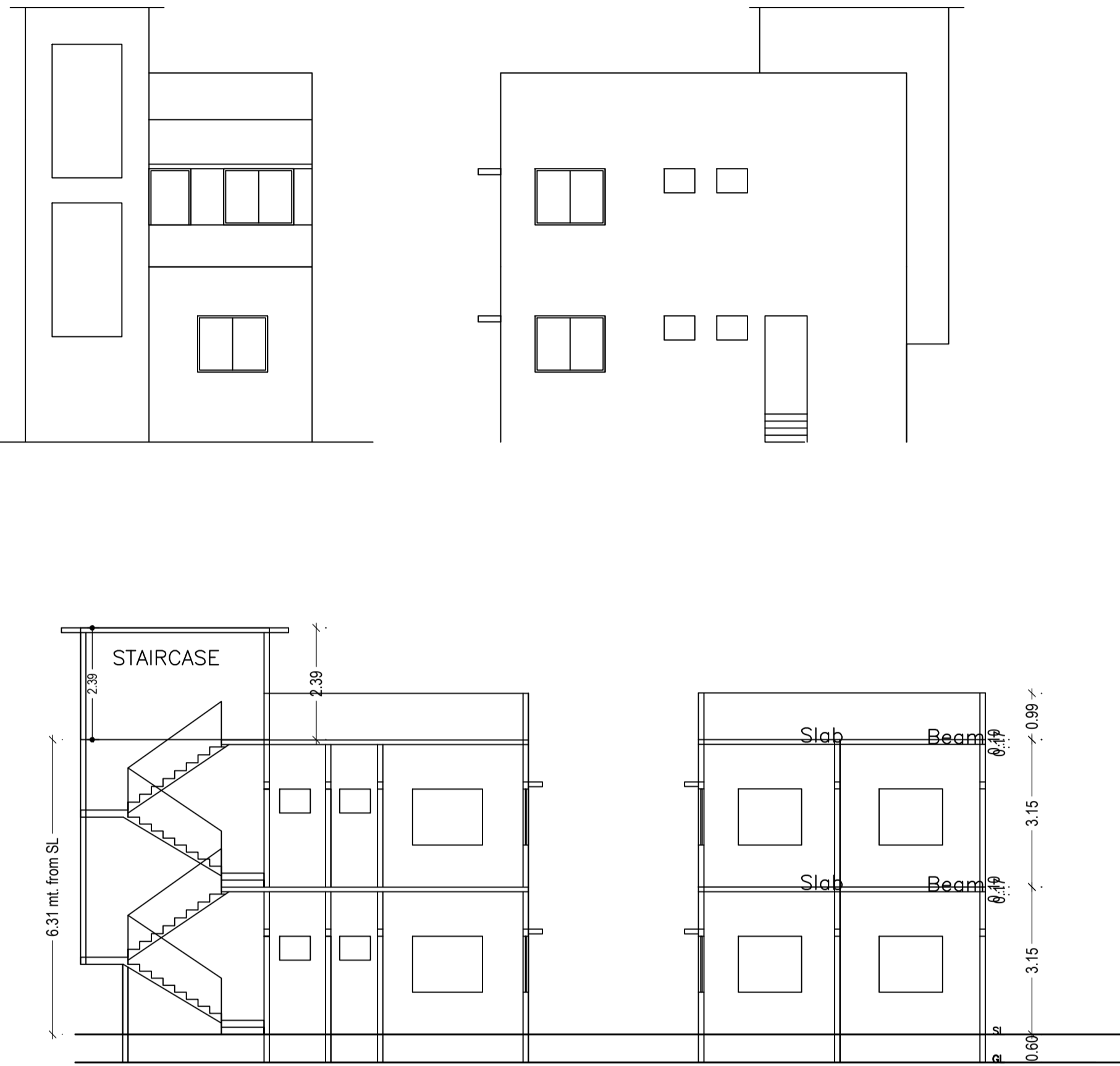
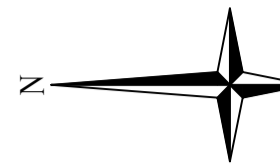
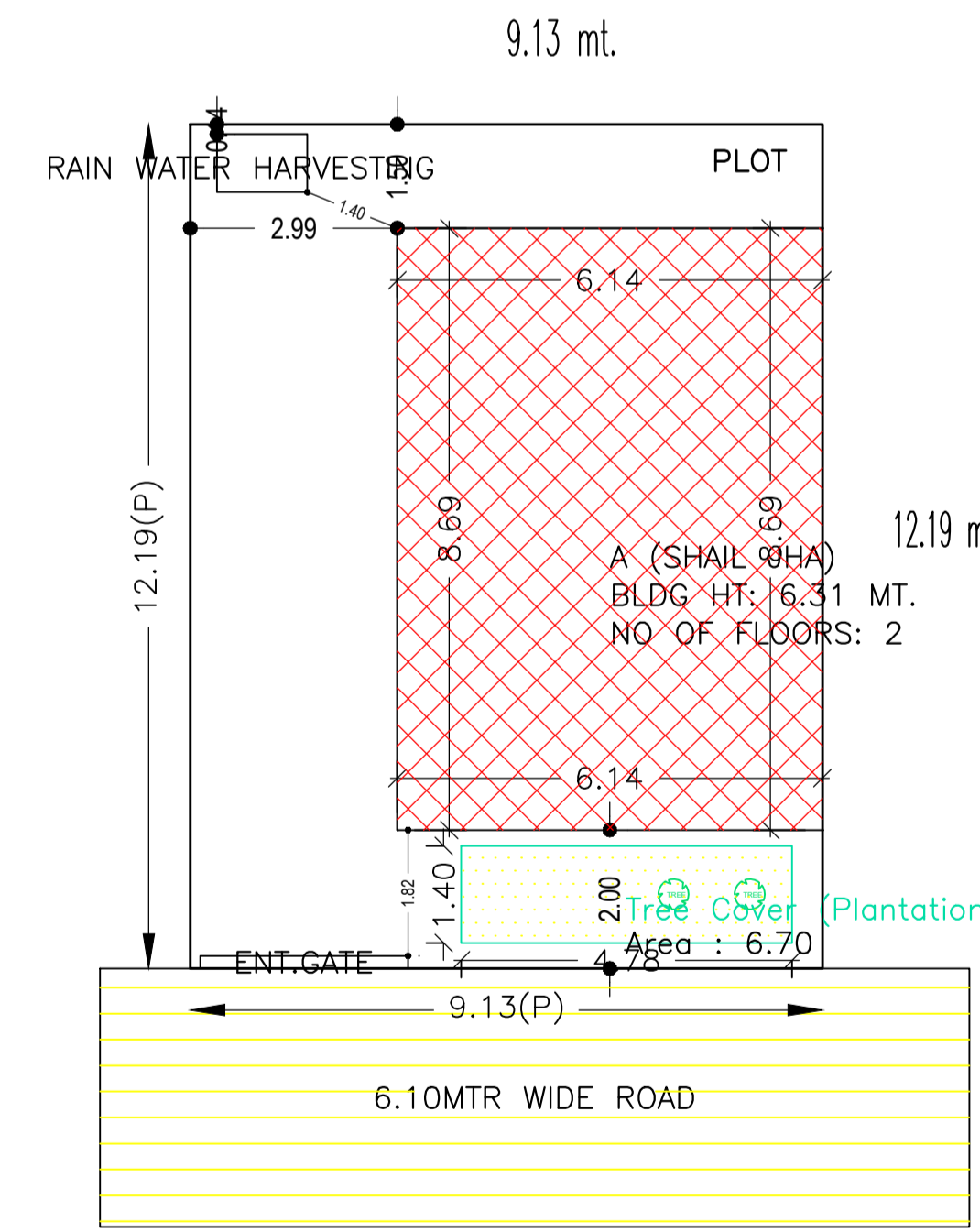
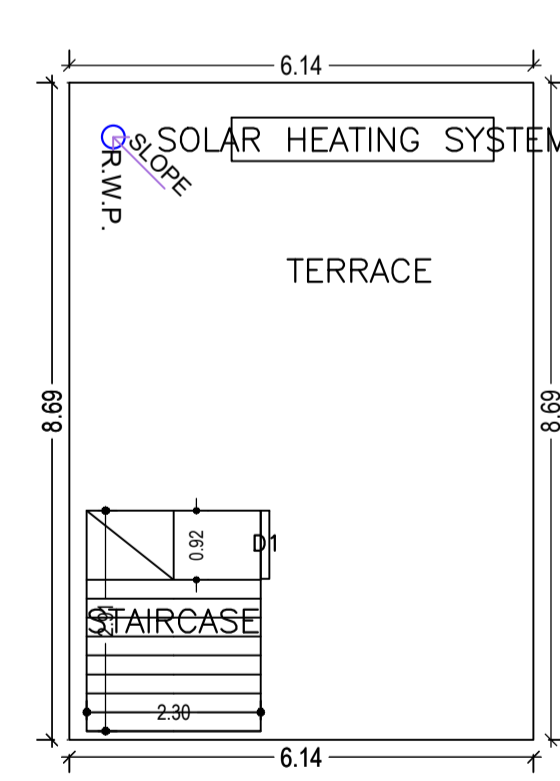
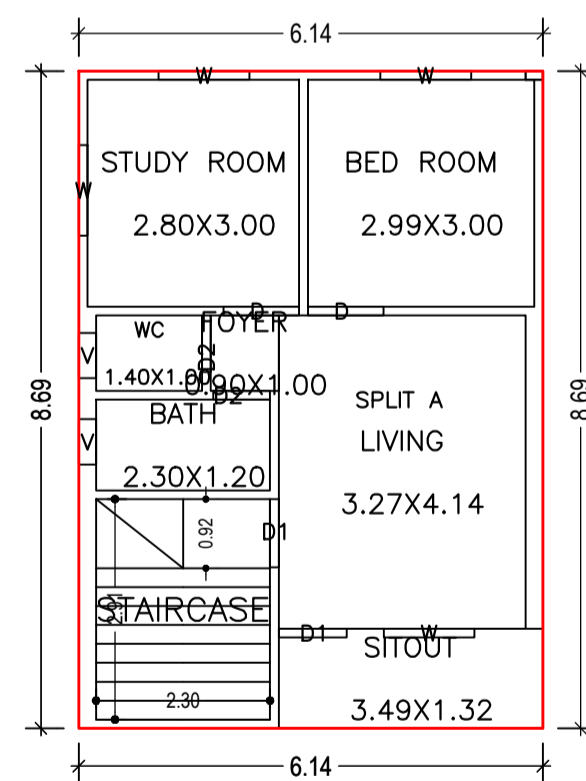
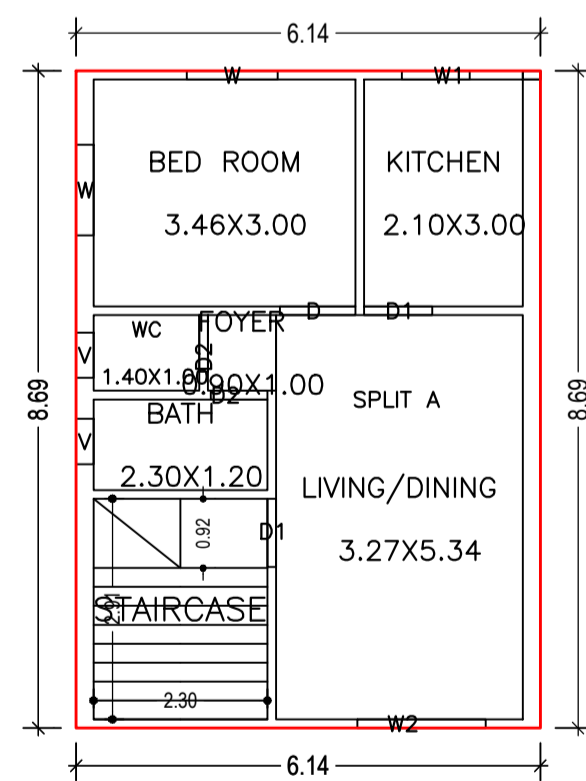

SCHEDULE OF DOOR:

BUILDING NAME	NAME	LENGTH	HEIGHT	NOS
A (SHAIL JHA)	D2	0.75	2.10	04
A (SHAIL JHA)	D1	0.90	2.10	04
A (SHAIL JHA)	D	1.00	2.10	03

SCHEDULE OF WINDOW/VENTILATION:

BUILDING NAME	NAME	LENGTH	HEIGHT	NOS
A (SHAIL JHA)	V	0.60	0.90	04
A (SHAIL JHA)	W1	0.90	1.20	01
A (SHAIL JHA)	W	1.20	1.20	06
A (SHAIL JHA)	W2	1.70	1.20	01

Building USE/SUBUSE Details

Building Name	Building Use	Building SubUse	Building Structure
A (SHAIL JHA)	Residential	Bungalow/ Dwelling / Non Apartment	Non-Highrise

COLOR INDEX

PLOT BOUNDARY	Black
ABUTTING ROAD	Green
PROPOSED CONSTRUCTION	Red
COMMON PLOT	Yellow
ROAD WIDENING AREA	Blue
EXISTING (To be retained)	Orange
EXISTING (To be demolished)	Grey

Buildingwise Floor FAR Details

Floor Name	Building Name A (SHAIL JHA)		Total	
	Proposed Built Up Area (Sq.mt.)	Proposed FAR Area (Sq.mt.)	Total Proposed Built Up Area (Sq.mt.)	Total FAR Area (Sq.mt.)
Ground Floor	53.36	53.36	53.36	53.36
First Floor	53.36	53.36	53.36	53.36
Terrace Floor	0.00	0.00	0.00	0.00
Total :	106.72	106.72	106.72	106.72

FAR & Tenement Details (Table 4c-1)

Building	No. of Same Bldg	Total Built Up Area (Sq.mt.)	Proposed FAR Area (Sq.mt.)	Total FAR Area (Sq.mt.)	Total Consumed Additional FAR Area (Sq.mt.)	Tnmt (No.)
A (SHAIL JHA)	1	106.72	106.72	106.72	106.72	01
Grand Total :	1	106.72	106.72	106.72	106.72	01

Building :A (SHAIL JHA)

Floor Name	Total Built Up Area (Sq.mt.)	Proposed FAR Area (Sq.mt.)	Total FAR Area (Sq.mt.)	Total Consumed Additional FAR Area (Sq.mt.)	Tnmt (No.)
Ground Floor	53.36	53.36	53.36	53.36	01
First Floor	53.36	53.36	53.36	53.36	00
Terrace Floor	0.00	0.00	0.00	0.00	00
Total :	106.72	106.72	106.72	106.72	01
Total Number of Same Buildings :	1				
Total :	106.72	106.72	106.72	106.72	01

UnitBUA Table for Building :A (SHAIL JHA)

FLOOR	Name	UnitBUA Type	UnitBUA Area	Carpet Area	No. of Rooms	No. of Tenement
GROUND FLOOR PLAN	SPLIT A	FLAT	106.71	106.66	6	1
FIRST FLOOR PLAN	SPLIT A	FLAT	0.00	0.00	7	0
Total :	-	-	106.71	106.66	13	1

LTP NAME AND SIGNATURE	STRUCTURAL ENG'S NAME AND SIGNATURE	BUILDER NAME AND SIGNATURE	DIGITAL SIGNATURE
AMRIT KUMAR MAHATO CMC/DFTMN/004/2019			