

Project Title :SHAIL JHA

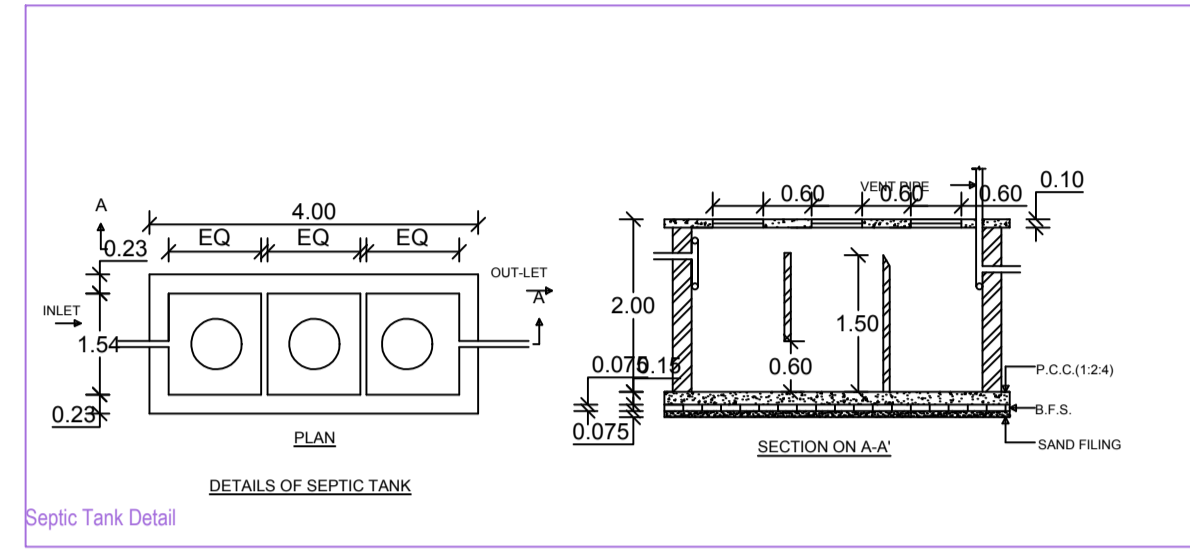

Septic Tank Detail

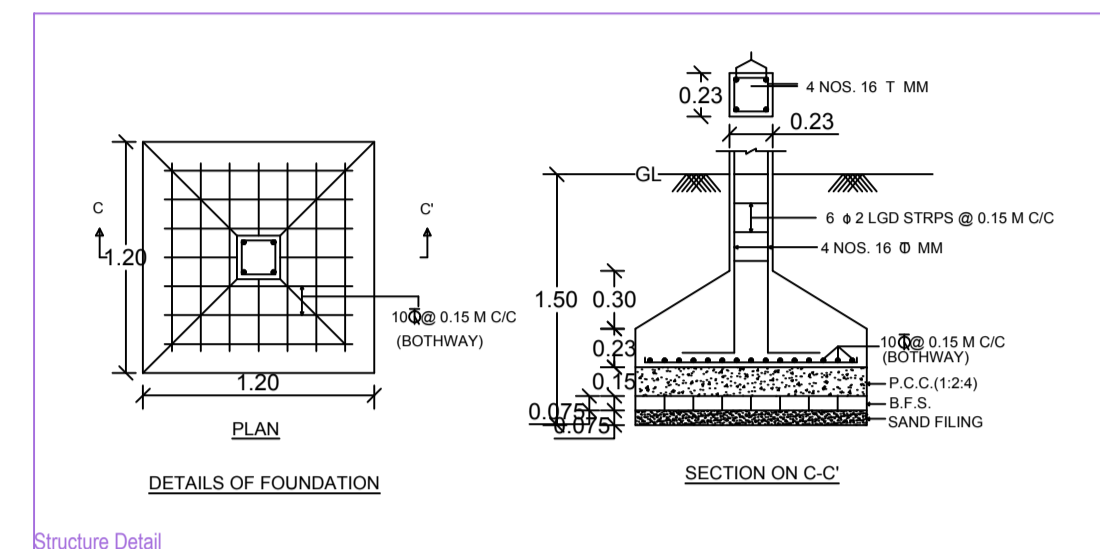

Structure Detail

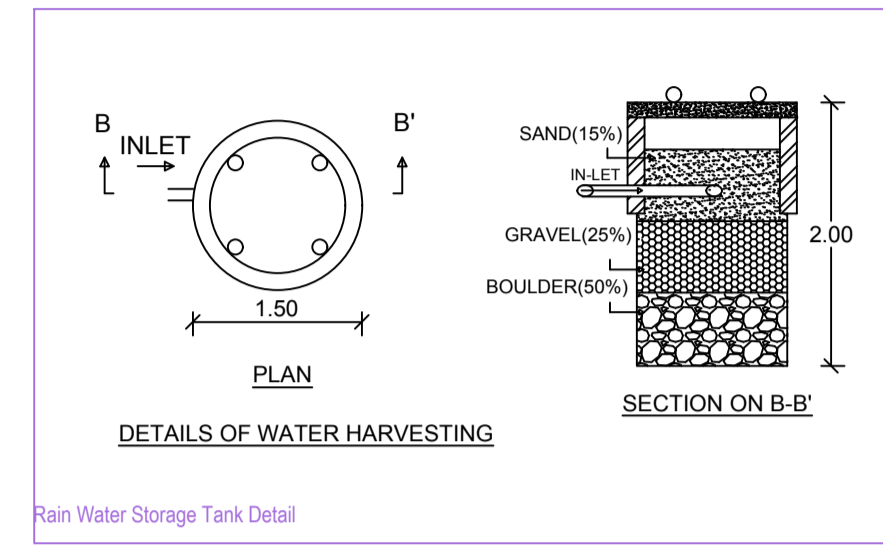

Rain Water Storage Tank Detail

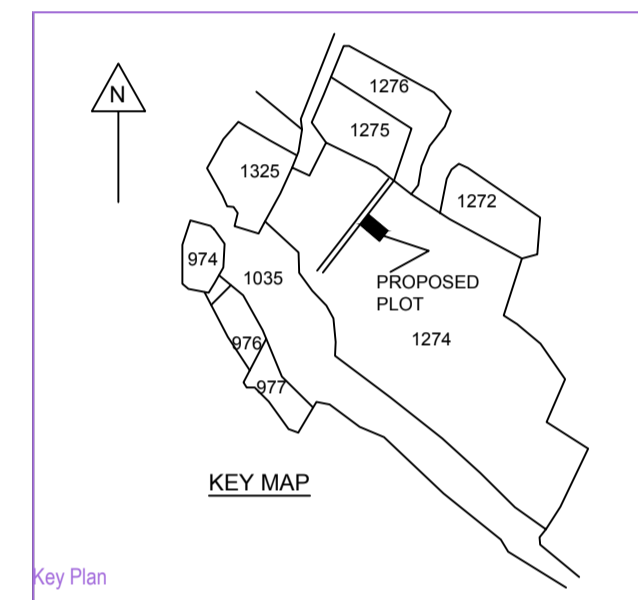
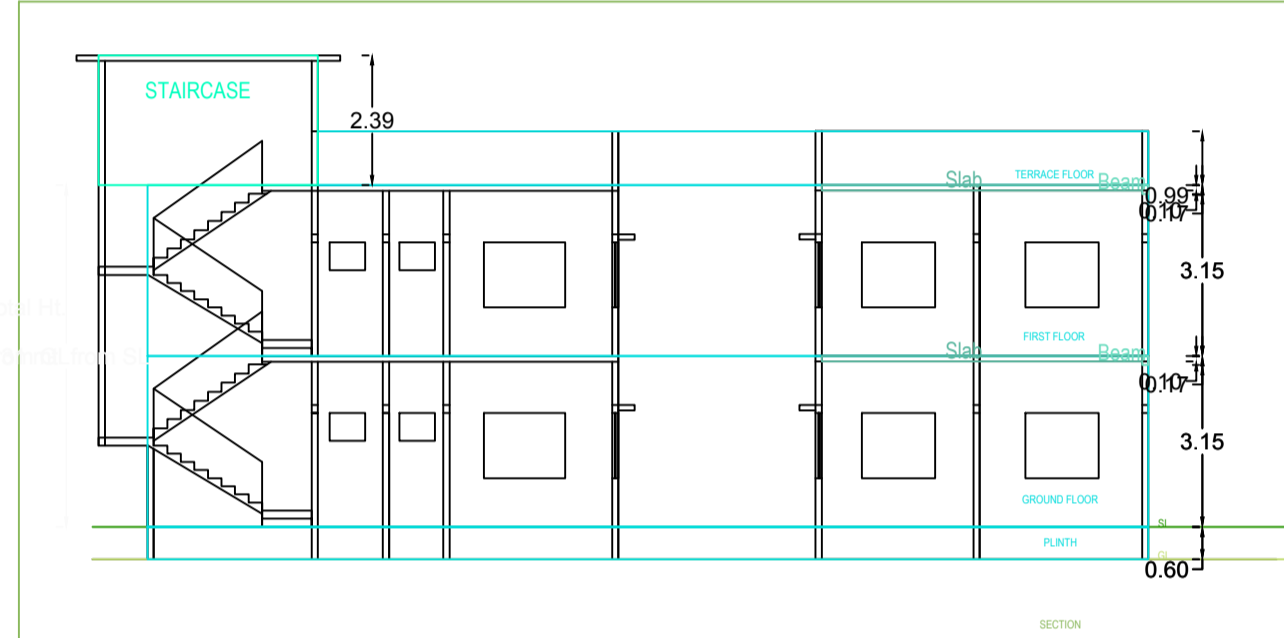
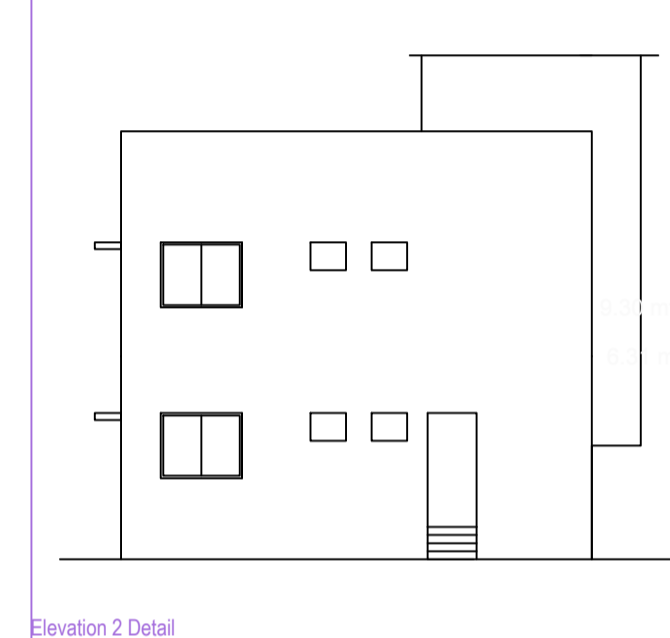
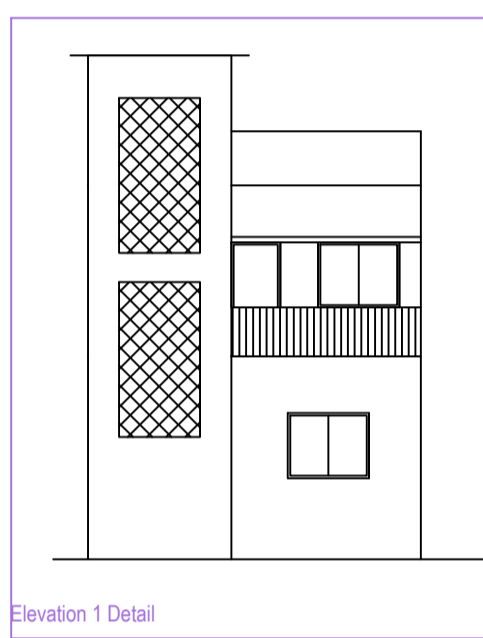

Key Plan

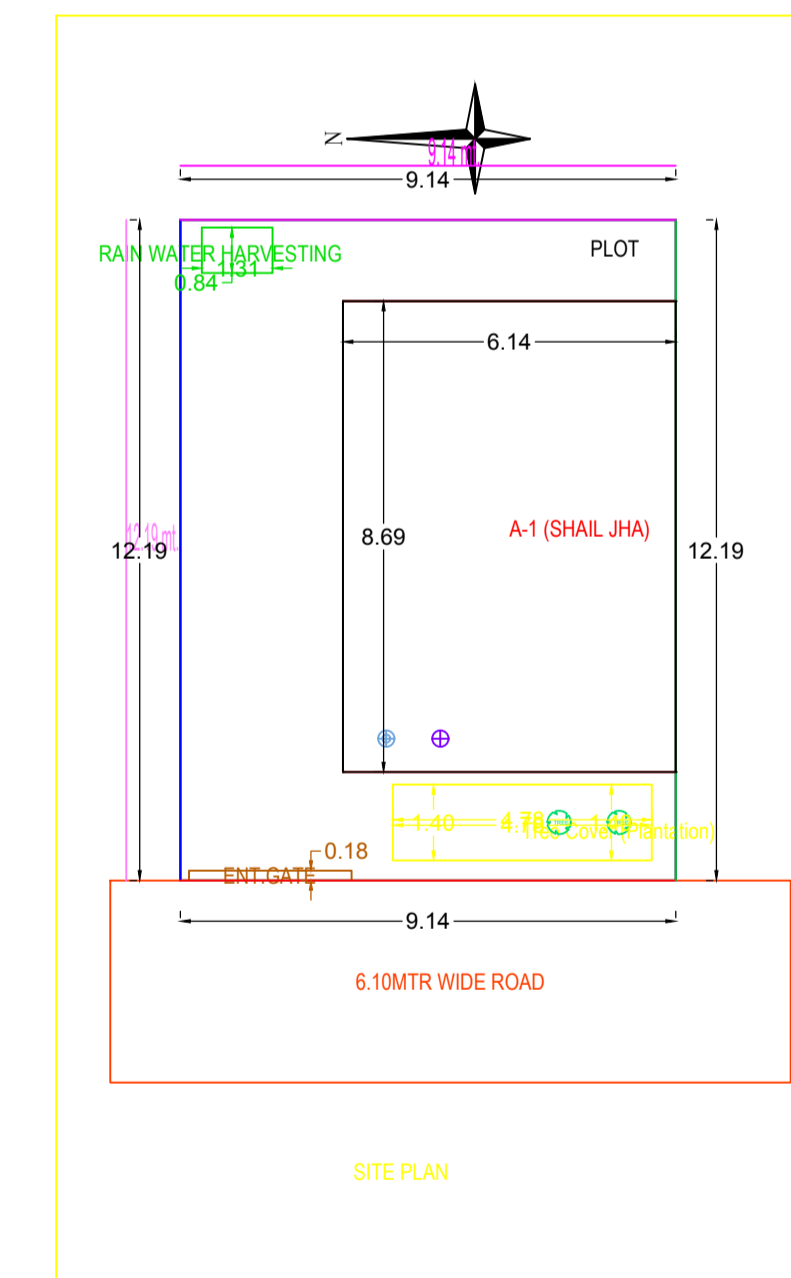
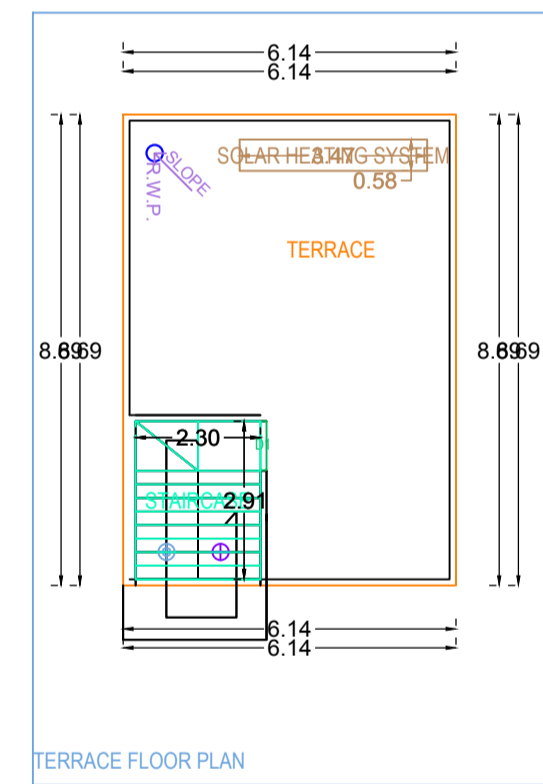
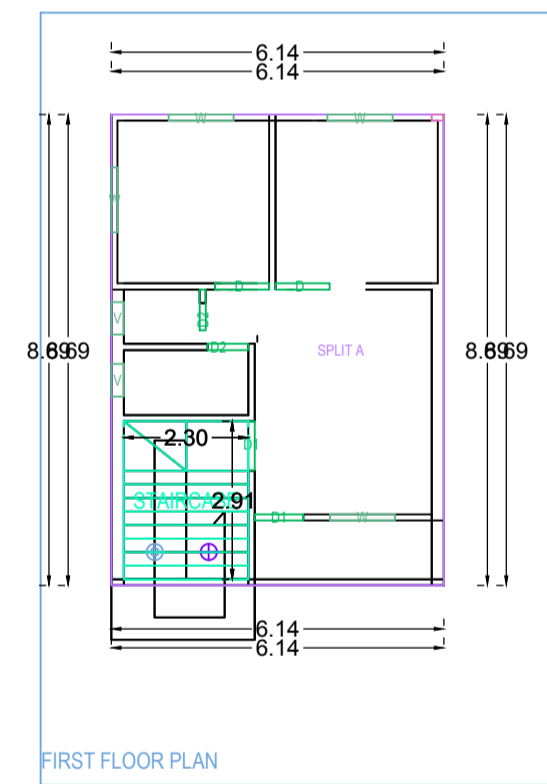
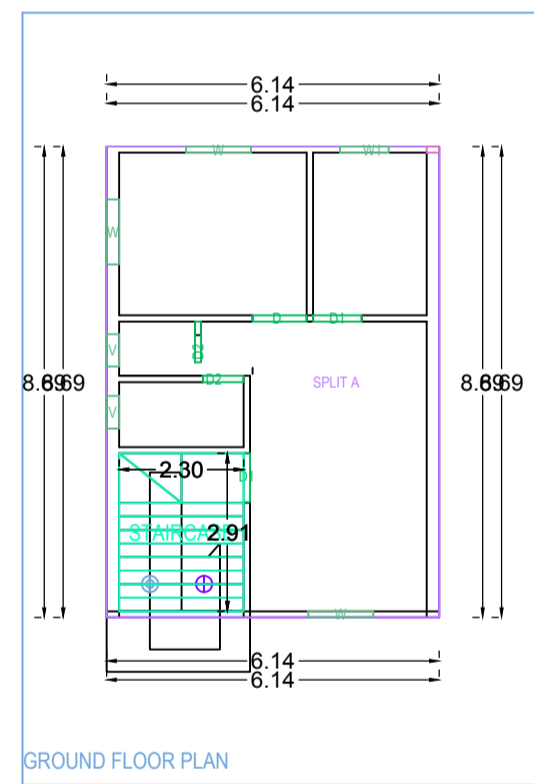

AREA STATEMENT: CHAS MUNICIPAL CORPORATION	VERSION NO: 1.0.36
PROJECT DETAIL:	VERSION DATE: 16/10/2020
Toward No.:	Plot Use: Residential
Region: JHARKHAND URBAN LOCAL BODIES	Plot SubUse: Bungalow/Dwelling / Non Apartment
District: BOKARO	Land Use Zone: NA
Application Type: General Proposal	Plotting/Road Width: -
Project Type: Building Permission	Plot No.:
Nature of Development: New	Revenue Survey No/Survey No.:
Location: Old Area	Thana No.:
Sub Location: NA	Holding No.:
Village/Moosa Name: -	Khata No.:
Ward No.:	North: -
Roadsheet: -	South: -
	East: -
	West: -

AREA DETAILS:		AREA	SQ.MT.
AREA OF PLOT (Minimum)	(A)		111.42
Net Plot Area (Gross Plot Area - Deduction from Gross Plot area)	(A-Deductions)		111.42
Deductions for Balance Plot Area (from Gross Plot Area)			
DCP Area			6.70
Total			6.70
Balance Plot Area (Net Plot Area - Recreational/Amenity space)	(A-Deductions)		104.71
Plot Area for Coverage (Net Plot Area)	(A-Deductions)		111.42
Plot Area for FSI (Net Plot Area + Road/Watering Area)	(A-Deductions)		111.42
COVERAGE CHECK			
Proposed Coverage Area (47.88 %)			53.36
Total Coverage Area (47.88 %)			53.36

FAR CHECK		
Proposed Area of FAR		106.72
Total Area of FAR		106.72
BUILT UP AREA CHECK		
Total Proposed BuiltUp Area		106.72
ARCHT/ENGG/ SUPERVISOR (Regd)		OWNER
DEVELOPMENT AUTHORITY		LOCAL BODY

MARGIN DETAIL:					
Building / Wing Name	Road Name	Front Margin	Rear Margin	Side1 Margin	Side2 Margin
A (SHAIL JHA)	6.10MTR WIDE ROAD	2.00	1.50	3.00	0.00

FAR & Tenement Details (Table 4c-1)					
Building	No. of Same Bldg	Total Built Up Area (Sq.mt)	Proposed FAR Area (Sq.mt)	Total FAR Area (Sq.mt)	Tenm (No.)
A (SHAIL JHA)	1	106.72	106.72	106.72	01
Grand Total	1	106.72	106.72	106.72	01

Building - A (SHAIL JHA)				
Floor Name	Total Built Up Area (Sq.mt)	Proposed FAR Area (Sq.mt)	Total FAR Area (Sq.mt)	Tenm (No.)
Ground Floor...	53.36	53.36	53.36	01
First Floor...	53.36	53.36	53.36	00
Terrace Floor...	0.00	0.00	0.00	00
Total	106.72	106.72	106.72	01
Total Number of Same Buildings	1			
Total	106.72	106.72	106.72	01

SCHEDULE OF JOINERY:				
BUILDING NAME	NAME	LENGTH	HEIGHT	NOS
A (SHAIL JHA)	D2	0.75	2.10	04
A (SHAIL JHA)	D1	0.90	2.10	05
A (SHAIL JHA)	D	1.00	2.10	03
Total	-	-	-	12

SCHEDULE OF JOINERY:				
BUILDING NAME	NAME	LENGTH	HEIGHT	NOS
A (SHAIL JHA)	V	0.60	1.00	04
A (SHAIL JHA)	W1	0.90	1.20	01
A (SHAIL JHA)	W	1.20	1.20	07
Total	-	-	-	12

UnitBUA Table for Building - A (SHAIL JHA)						
FLOOR	Name	UnitBUA Type	UnitBUA Area	Carpet Area	No. of Rooms	No. of Tenement
GROUND FLOOR PLAN	SPLIT A	FLAT	106.71	106.66	6	1
Total	-	-	106.71	106.66	13	1