

Project Title: NASRIN BANO

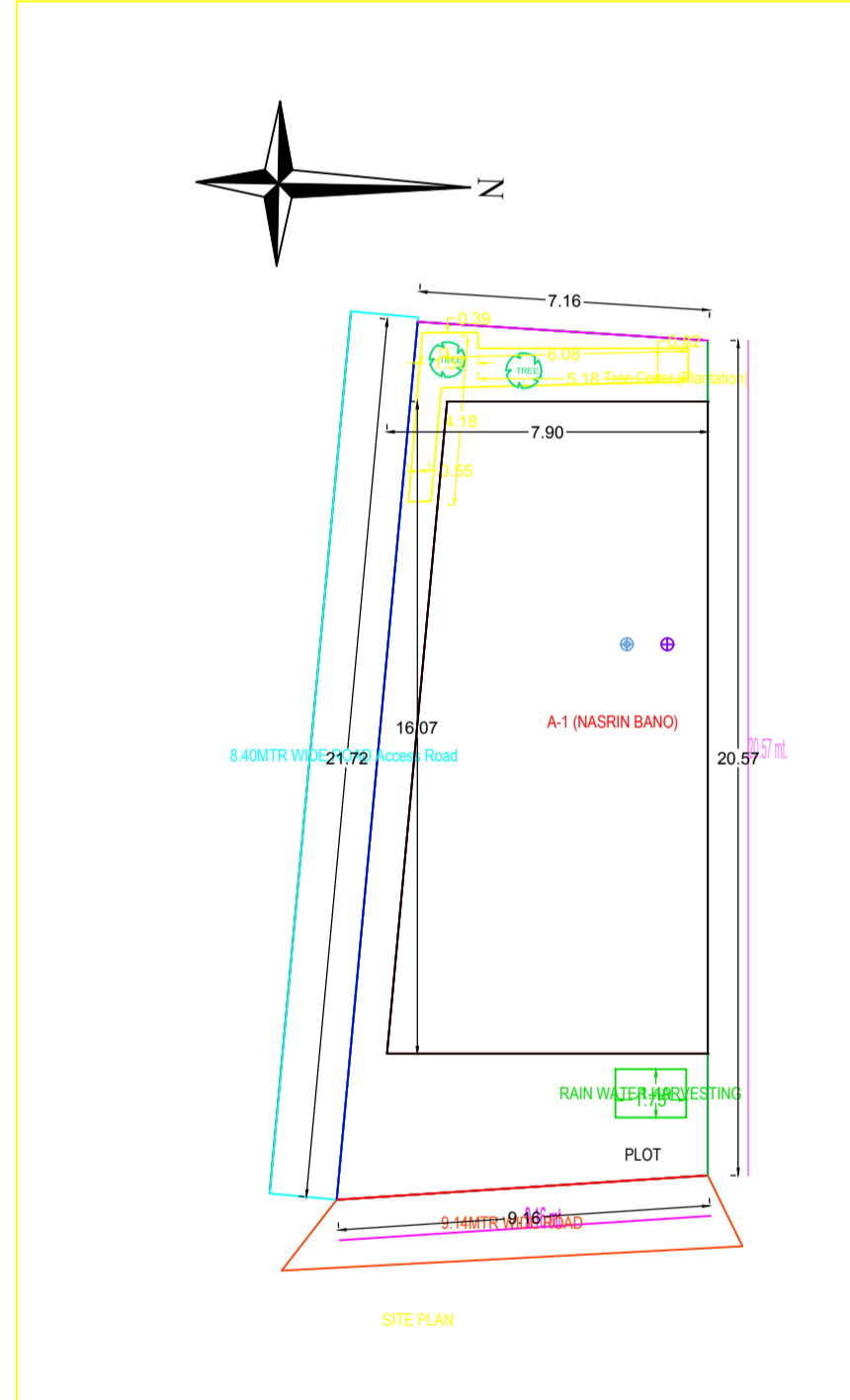
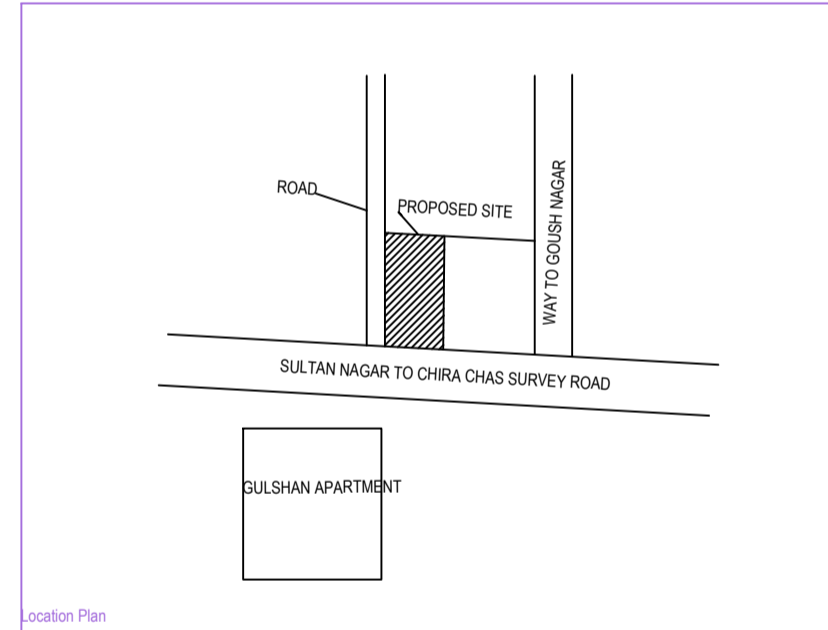
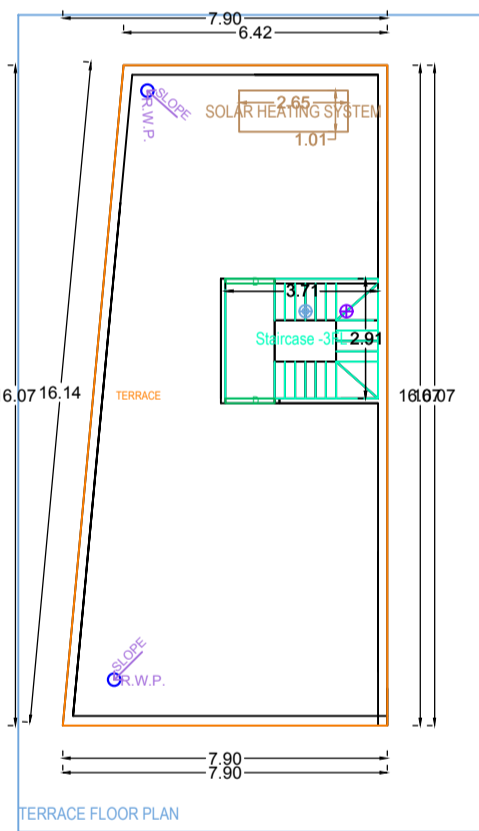
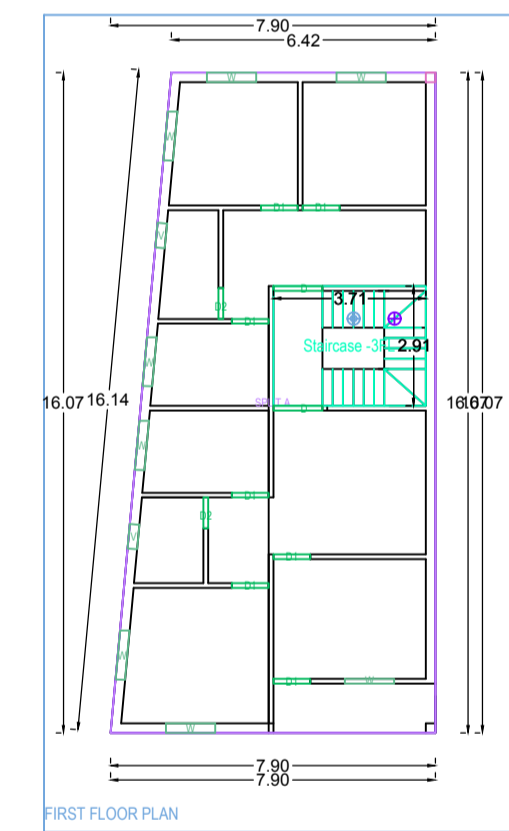
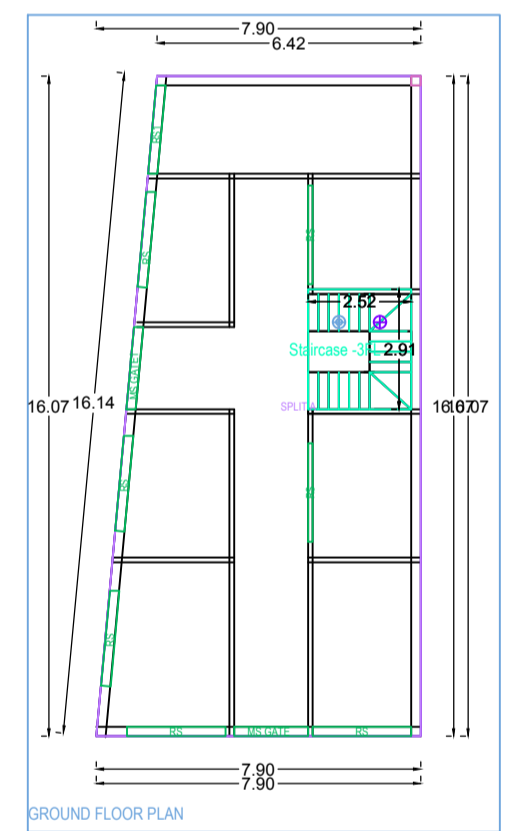
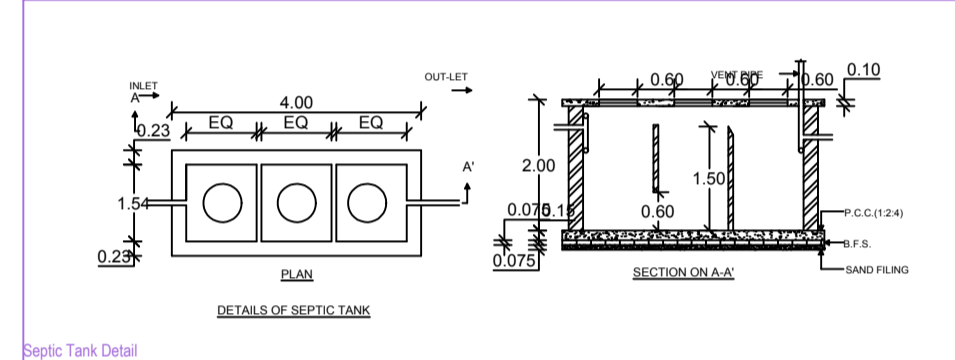
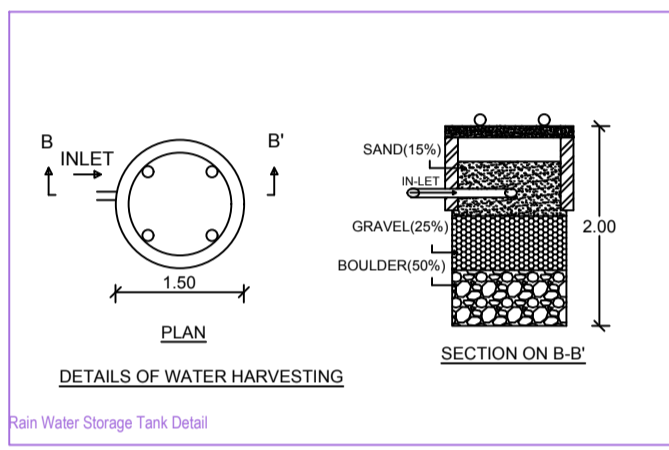
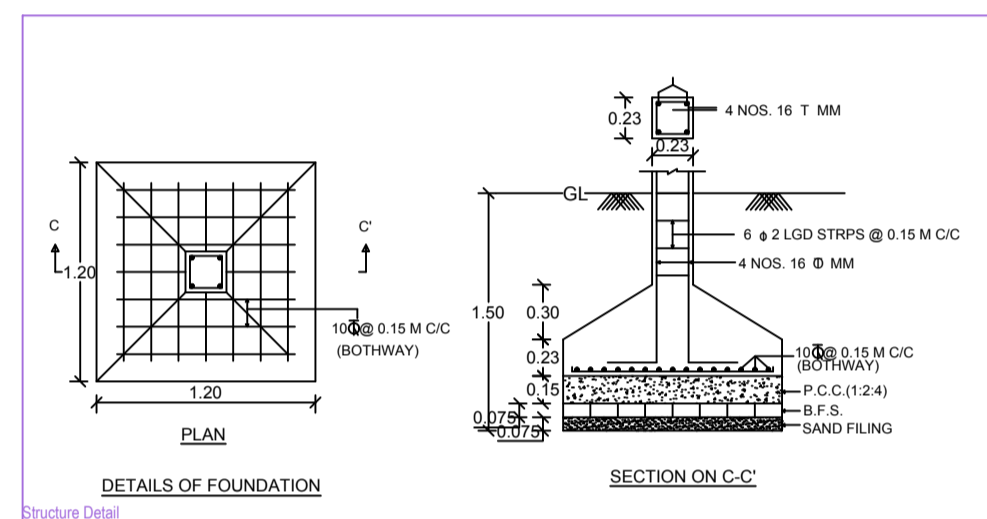
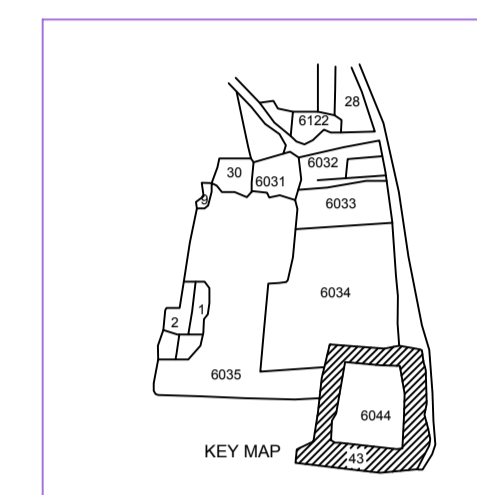
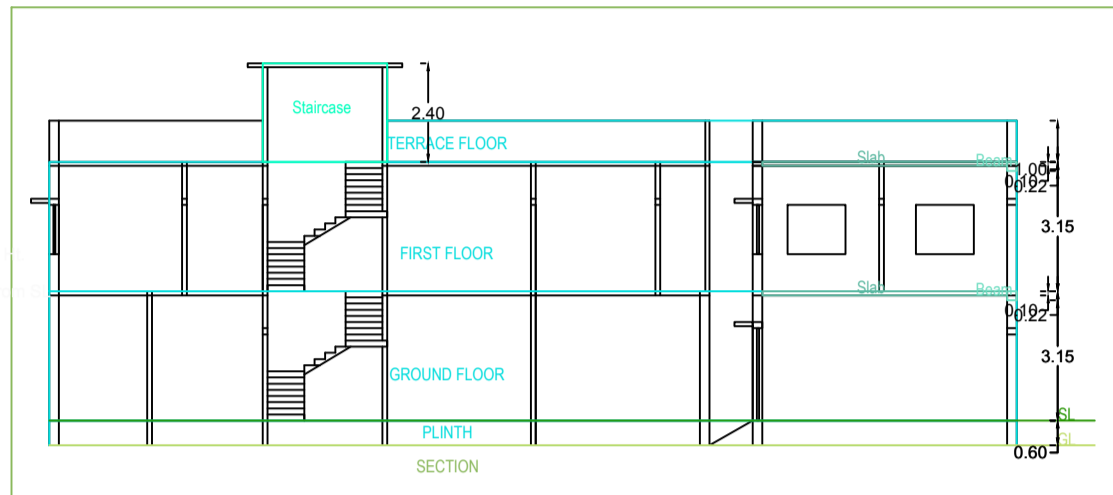
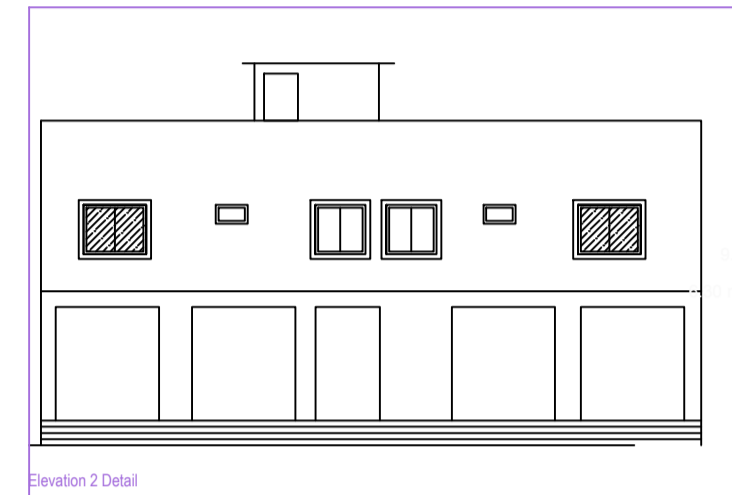
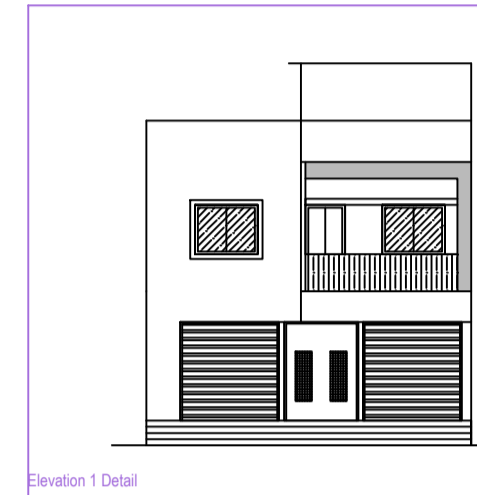

Building A (NASRIN BANO)

Floor Name	Total Built Up Area (Sq. m)	Proposed FAR Area (Sq. m)	Total FAR Area (Sq. m)	Area (%)
Ground Floor	116.11	116.11	116.11	53
First Floor	116.11	116.11	116.11	53
Terrace Floor	0.00	0.00	0.00	0
Total	232.22	232.22	232.22	100

SCHEDULE OF JOINERY:

BEARING NAME	NAME	LENGTH	HEIGHT	NOS
"	DO	3.75	2.10	02
"	DO	3.90	2.10	02
"	DO	1.20	2.10	04
"	MS GATE	1.80	2.40	01
"	MS GATE	2.00	2.40	01
"	MS	2.50	2.40	01
"	MS	2.50	2.40	01
"	MS	2.40	2.10	02
Total	-	-	-	23

SCHEDULE OF JOINERY:

BEARING NAME	NAME	LENGTH	HEIGHT	NOS
"	V	3.60	1.00	02
"	H	1.20	1.20	02
Total	-	-	-	10

Unit/BUA Table for Building A (NASRIN BANO)

AREA STATEMENT: CHAS MUNICIPAL CORPORATION

PROJECT NO.	PROJECT NAME	PROJECT TYPE	PROJECT STATUS
6030	RESIDENTIAL	RESIDENTIAL	UNDER CONSTRUCTION

AREA DETAILS:

AREA OF PLOT (Sqm)	AREA OF PLOT (Sqm)
232.22	232.22

COLOR INDEX:

Color	Description
Red	Plot Boundary
Green	Abutting Road
Blue	Proposed Water Coverage Area
Yellow	Existing To be retained
Black	Existing To be demolished

MARGIN DETAIL:

Building	Width	Road Name	Front Margin	Rear Margin	Side Margin	Setback
A1 (NASRIN BANO)	1.50MTR WIDE ROAD	ROAD	3.00	1.50	0.90	0.00

FAR & Tenement Details (Table 4c-1)

Building	No. of Units	Total Built Up Area (Sq. m)	Proposed FAR Area (Sq. m)	Total FAR Area (Sq. m)
A1 (NASRIN BANO)	1	232.22	232.22	232.22