

Project Title : RAJANI SHARAN

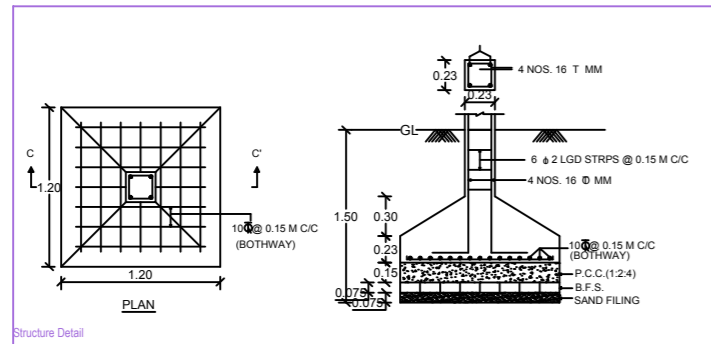

Structure Detail

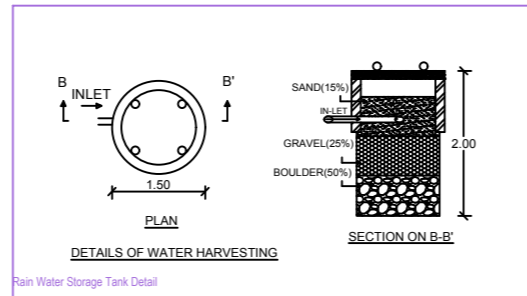

Rain Water Storage Tank Detail

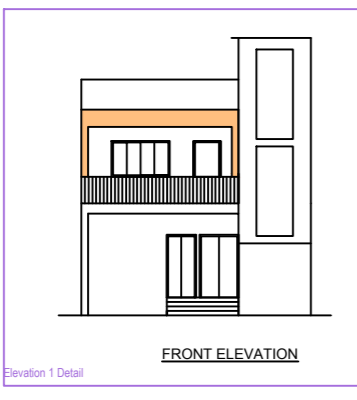
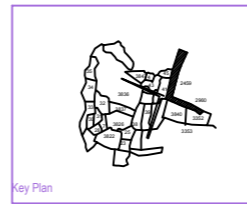

Elevation 1 Detail

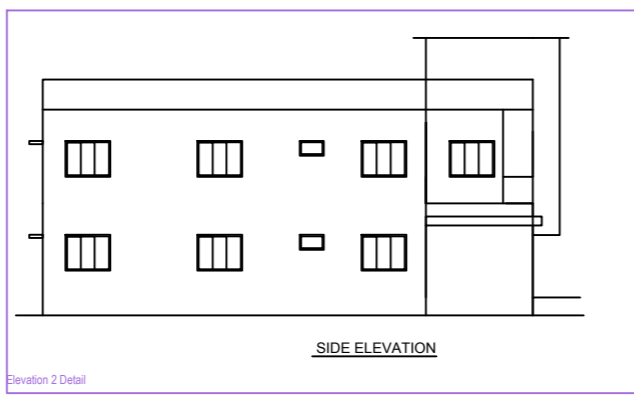

Elevation 2 Detail

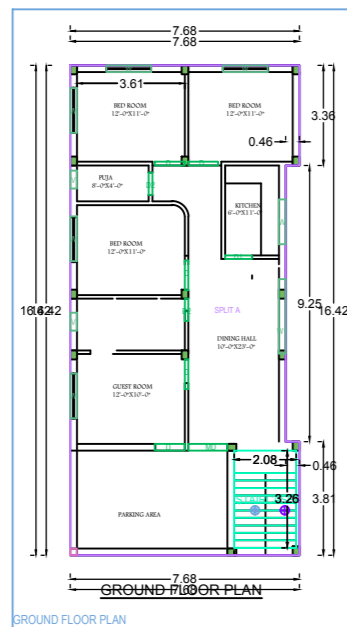
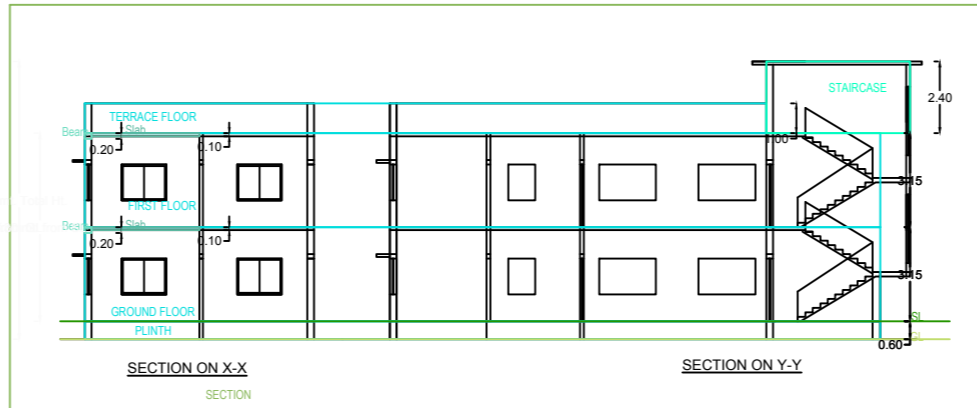

GROUND FLOOR PLAN

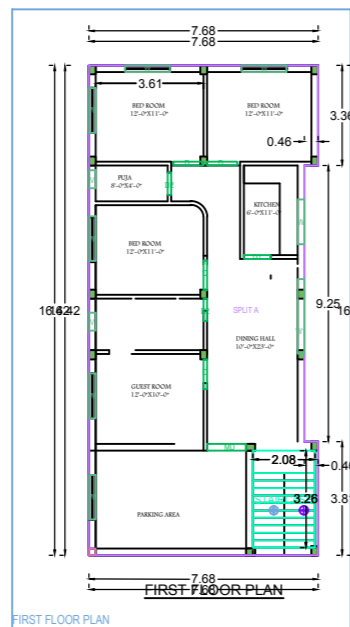

FIRST FLOOR PLAN

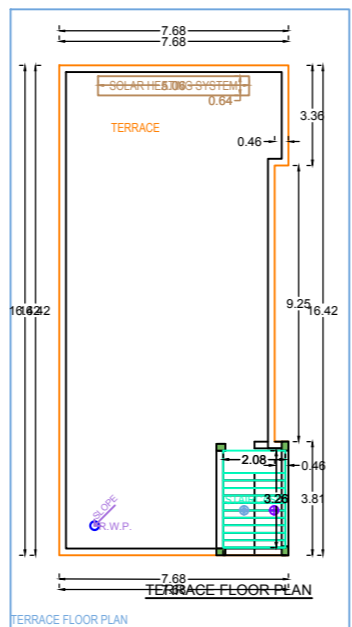

TERRACE FLOOR PLAN

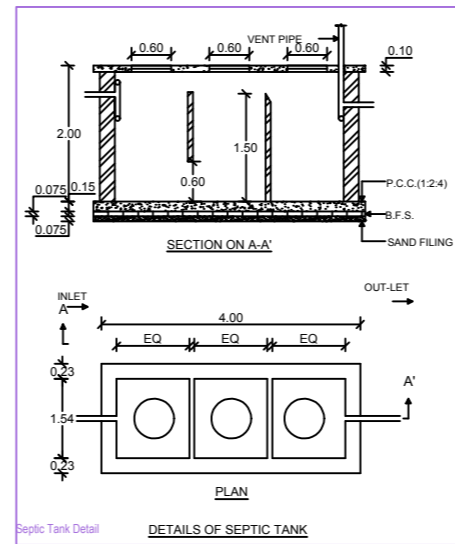

Septic Tank Detail

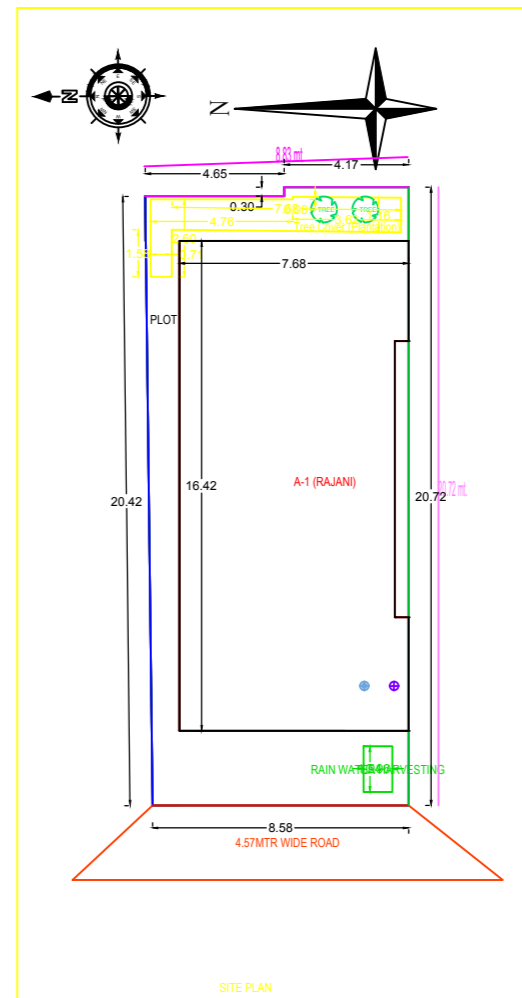

SITE PLAN

AREA STATEMENT CHAN MUNICIPAL CORPORATION	SECTION NO. 13.08
PROJECT DETAIL	SECTION DATE: 18/10/2020
Project No.	Plot Use - Residential
Region - JHARKHAND URBAN LOCAL BODIES	Plot Location - Bungalow/ Dwelling/ Non- Apartment
LOCAL BODIES	Local Use Zone - RA
Application Type - General Proposal	Abutting Road Width -
Project Type - Building/Extension	Plot No.
Number of Development - New	Reference Survey No./Survey No.
Location -	Planning No.
Sub Location - RA	Zone No.
Map/Reference Name -	Block -
Sheet No.	Section -
Plot/Sheet -	Depth -
East -	West -

AREA TABLE	UNIT	201.87	138.82
AREA OF PLOT (Minimum)	(A)		138.82
Net PFA Area (Less PFA Area - Deduction from Gross PFA Area)	(A-Deductions)		138.82
Deductions for Motor PFA Area (from Gross PFA Area)			
COF PFA		12.28	
Net PFA Area (Net PFA Area - Deductions/Net PFA Area)	(A-Deductions)		12.28
Net PFA Area for Coverage (Net PFA Area)	(A-Deductions)		12.28
Net PFA Area for PFA (Net PFA Area + Road/Highway Area)	(A-Deductions)		12.28
Proposed Coverage Area (Net PFA %)		121.81	
Net PFA Area (Net PFA %)		121.81	

Color Index	Color
PROPOSED WORK (COVERAGE AREA)	Green
EXISTING (To be retained)	Yellow
EXISTING (To be demolished)	Red

Color Index	Color
PROPOSED WORK (COVERAGE AREA)	Green
EXISTING (To be retained)	Yellow
EXISTING (To be demolished)	Red

Color Index	Color
PROPOSED WORK (COVERAGE AREA)	Green
EXISTING (To be retained)	Yellow
EXISTING (To be demolished)	Red

Color Index	Color
PROPOSED WORK (COVERAGE AREA)	Green
EXISTING (To be retained)	Yellow
EXISTING (To be demolished)	Red

Color Index	Color
PROPOSED WORK (COVERAGE AREA)	Green
EXISTING (To be retained)	Yellow
EXISTING (To be demolished)	Red

Color Index	Color
PROPOSED WORK (COVERAGE AREA)	Green
EXISTING (To be retained)	Yellow
EXISTING (To be demolished)	Red

Color Index	Color
PROPOSED WORK (COVERAGE AREA)	Green
EXISTING (To be retained)	Yellow
EXISTING (To be demolished)	Red

Color Index	Color
PROPOSED WORK (COVERAGE AREA)	Green
EXISTING (To be retained)	Yellow
EXISTING (To be demolished)	Red

Color Index	Color
PROPOSED WORK (COVERAGE AREA)	Green
EXISTING (To be retained)	Yellow
EXISTING (To be demolished)	Red

Color Index	Color
PROPOSED WORK (COVERAGE AREA)	Green
EXISTING (To be retained)	Yellow
EXISTING (To be demolished)	Red

Color Index	Color
PROPOSED WORK (COVERAGE AREA)	Green
EXISTING (To be retained)	Yellow
EXISTING (To be demolished)	Red

Floor Name	Total Built Up Area (Sq.M)	Proposed PFA Area (Sq.M)	Total PFA Area (Sq.M)	Trent (No.)
Ground Floor	121.81	121.81	121.81	01
First Floor	121.81	121.81	121.81	02
Terrace Floor	2.00	2.00	2.00	01
Total	243.62	243.62	243.62	03
Net Number of Same Buildings	1			
Total	243.62	243.62	243.62	03

SCHEDULE OF JOINERY:	ITEM NAME	LENGTH	HEIGHT	NO.
A (RAJANI)	CD	0.75	2.10	01
A (RAJANI)	CD	0.90	2.10	02
A (RAJANI)	CD	1.00	2.10	03
A (RAJANI)	MD	1.35	2.10	02
Total				07

SCHEDULE OF JOINERY:	ITEM NAME	LENGTH	HEIGHT	NO.
A (RAJANI)	V	0.80	1.80	04
A (RAJANI)	V	1.50	1.80	13
A (RAJANI)	WT	2.30	1.80	02
Total				19

UNBILUA Table for Building - A (RAJANI)	FLOOR	Name	UNBILUA Type	UNBILUA Area	Overall Area	No. of Rooms	No. of Tenements
GROUND FLOOR	SPLIT A	FLAT		243.61	243.61	3	1
				243.61	243.61	18	1