

Proposal Basic Information

Proposal File No.	CMC/BP/0245/W05/2023
Owner Name	GITA DEVI
Khata No	102
Plot No	1217,1218
Village Name	Jamgoria
Use	Residential
SubUse	Bungalow/ Dwelling / Non Apartment

AREA STATEMENT CHAS MUNICIPAL CORPORATION  
VERSION NO.: 1.0.66  
VERSION DATE: 16/10/2020

Region: JHARKHAND URBAN LOCAL BODIES	Plot Use: Residential
District: BOKARO	Plot SubUse: Bungalow/ Dwelling / Non Apartment
Authority: CHAS MUNICIPAL CORPORATION	PlotNearbyReligiousStructure: NA
Inward No: CMC/BP/0245/W05/2023	PlotSubPlot No: 1217,1218
Application Type: General Proposal	North: Plot No. - 10 MARK LAND
Project Type: Building Permission	South: Road Width - 6.10 M ROAD
Nature of Development: New	East: Plot No. - 1215
Location of Development Area: Old Area	West: Road Width - 6.10 M ROAD

AREA OF PLOT (Minimum)	(A)	SQ.MT.	125.09
NET AREA OF PLOT(Gross Plot Area - Deduction from Gross Plot area)	(A-Deductions)		125.09
Deduction for Balance Plot Area(from Gross Plot Area)			
Common Plot			22.67
Total			22.67
BALANCE AREA OF PLOT(Net Plot Area - Recreational/Amenity space)	(A-Deductions)		102.41
PLOT AREA FOR COVERAGE(Net Plot Area)	(A-Deductions)		125.09
Plot Area for FAR (Net Plot Area + Road Widening Area)	(A-Deductions)		125.09

COVERAGE CHECK			
Permissible Coverage area ( 70.00 % )			87.56
Proposed Coverage Area ( 67.08 % )			83.91
Total Prop. Coverage Area ( 67.08 % )			83.91
Balance coverage area ( 2.92 % )			3.65
FAR CHECK			
Perm. FAR Area ( 2.500 )			312.72
Total Perm. FAR area			312.72
Residential FAR			167.82
Proposed FAR Area			167.82
Total Proposed FAR Area			167.82
Consumed FAR (Factor)			1.34
Balance FAR Area			144.90

BUILT UP AREA CHECK		Total Proposed BuiltUp Area	167.82
ARCHITECT (Regd)	RAVI KUMAR		
ENGINEER (Regd)			
SUPERVISOR (Regd)			
OWNER (Regd)	GITA DEVI		
DEVELOPMENT AUTHORITY		LOCAL BODY	

Building :A ( RESIDENTIAL )					
Floor Name	Total Built Up Area (Sq.mt.)	Proposed FAR Area (Sq.mt.) Resi.	Total FAR Area (Sq.mt.)	Total Consumed Additional FAR Area (Sq.mt.)	Tnmt (No.)
Ground Floor	83.91	83.91	83.91	83.91	01
First Floor	83.91	83.91	83.91	83.91	00
Terrace Floor	0.00	0.00	0.00	0.00	00
Total :	167.82	167.82	167.82	167.82	01
Total Number of Same Buildings	1				
Total :	167.82	167.82	167.82	167.82	01

Buildingwise Floor FAR Details				
Floor Name	Building Name A (RESIDENTIAL)		Total	
	Proposed Built Up Area (Sq.mt.)	Proposed FAR Area (Sq.mt.)	Total Proposed Built Up Area (Sq.mt.)	Total FAR Area (Sq.mt.)
Ground Floor	83.91	83.91	83.91	83.91
First Floor	83.91	83.91	83.91	83.91
Terrace Floor	0.00	0.00	0.00	0.00
Total :	167.82	167.82	167.82	167.82

UnitBUA Table for Building :A ( RESIDENTIAL )						
FLOOR	Name	UnitBUA Type	UnitBUA Area	Carpel Area	No. of Rooms	No. of Tenement
GROUND FLOOR PLAN	SPLIT 1	FLAT	167.82	167.66	5	1
FIRST FLOOR PLAN	SPLIT 1	FLAT	0.00	0.00	10	0
Total:	-	-	167.82	167.66	15	1

SCHEDULE OF DOOR:				
BUILDING NAME	NAME	LENGTH	HEIGHT	NOS
A (RESIDENTIAL)	D3	0.75	2.10	04
A (RESIDENTIAL)	D2	0.87	2.10	01
A (RESIDENTIAL)	D1	1.00	2.10	02
A (RESIDENTIAL)	D	1.00	2.10	05

SCHEDULE OF WINDOW/VENTILATION:				
BUILDING NAME	NAME	LENGTH	HEIGHT	NOS
A (RESIDENTIAL)	V	0.60	1.20	03
A (RESIDENTIAL)	W1	1.20	1.20	09
A (RESIDENTIAL)	W	2.00	1.20	03

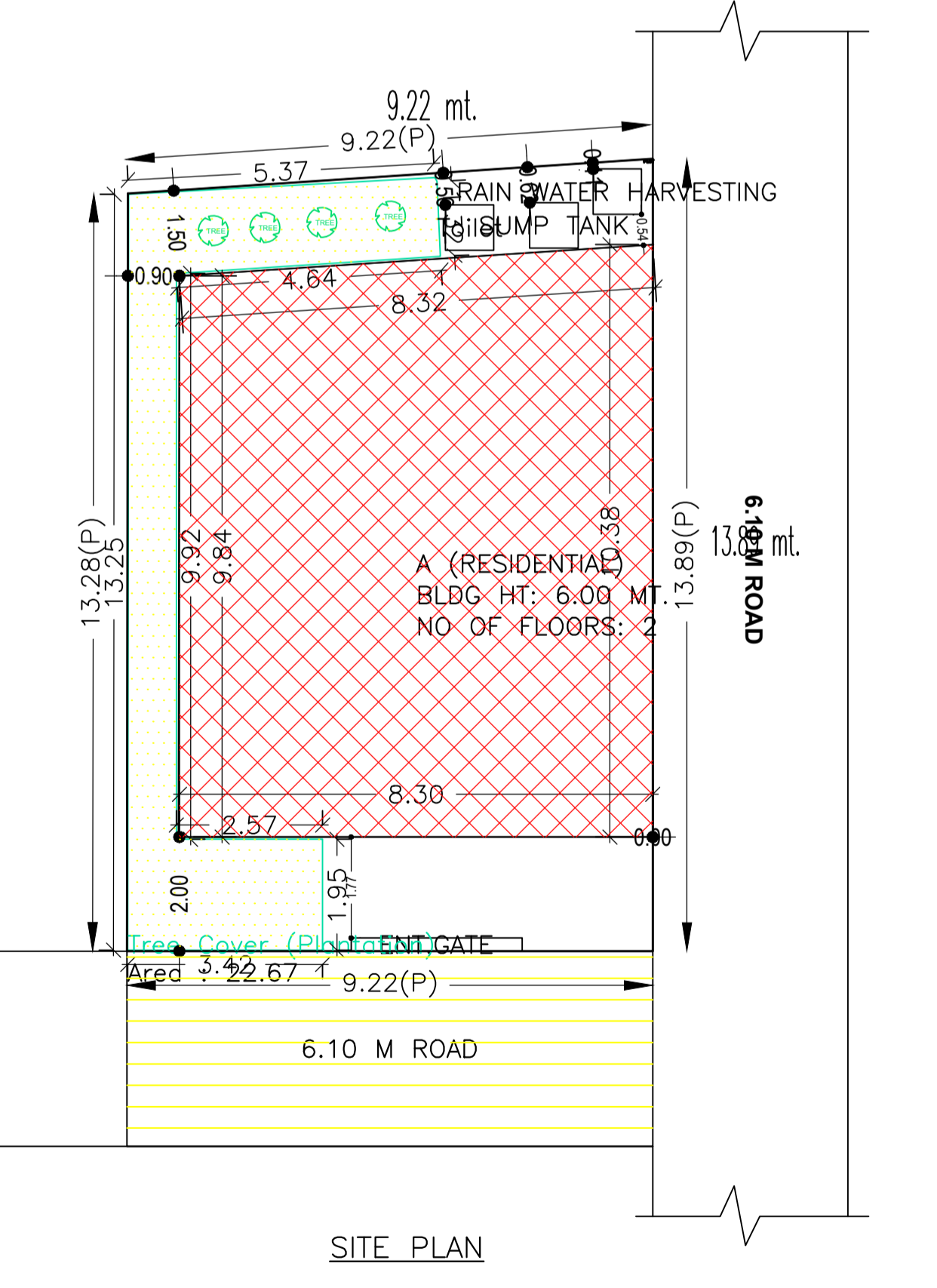
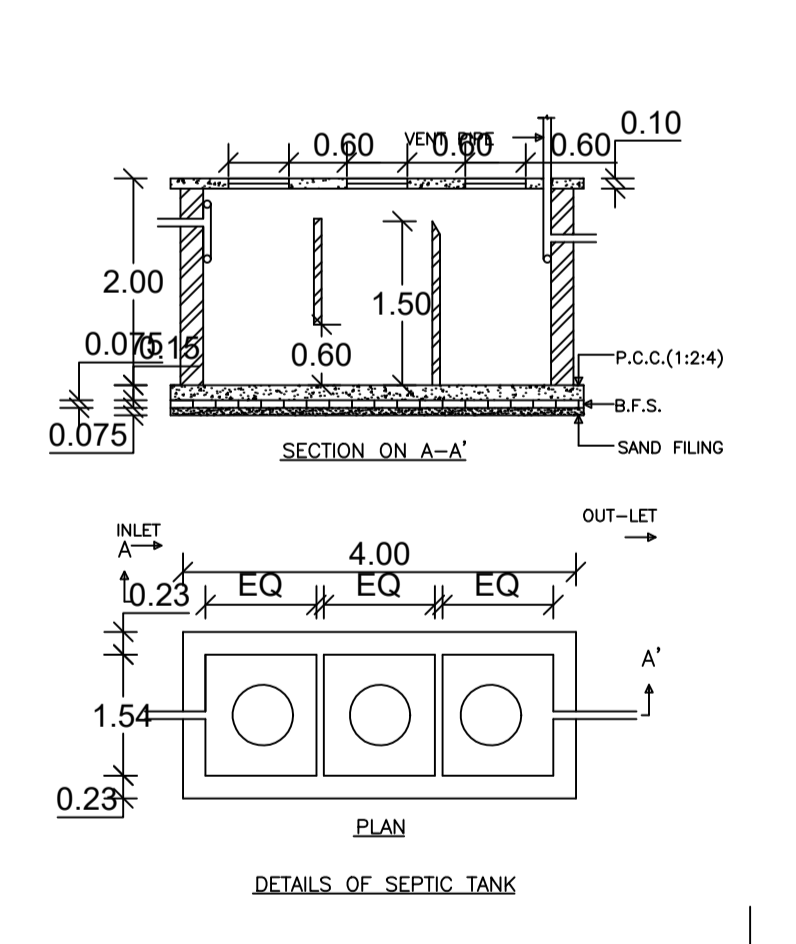
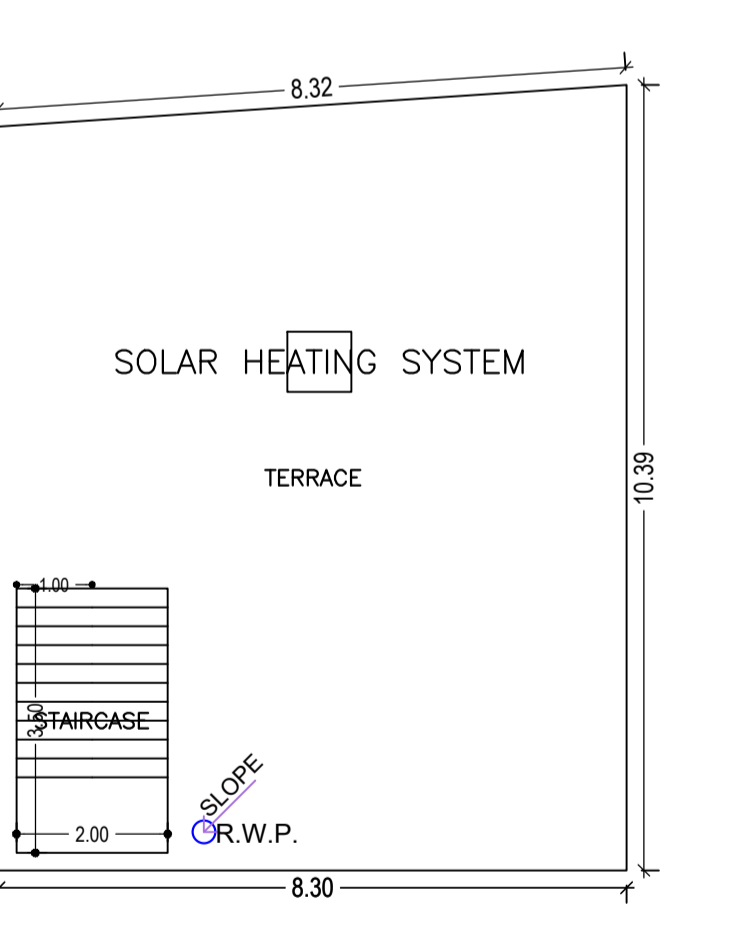
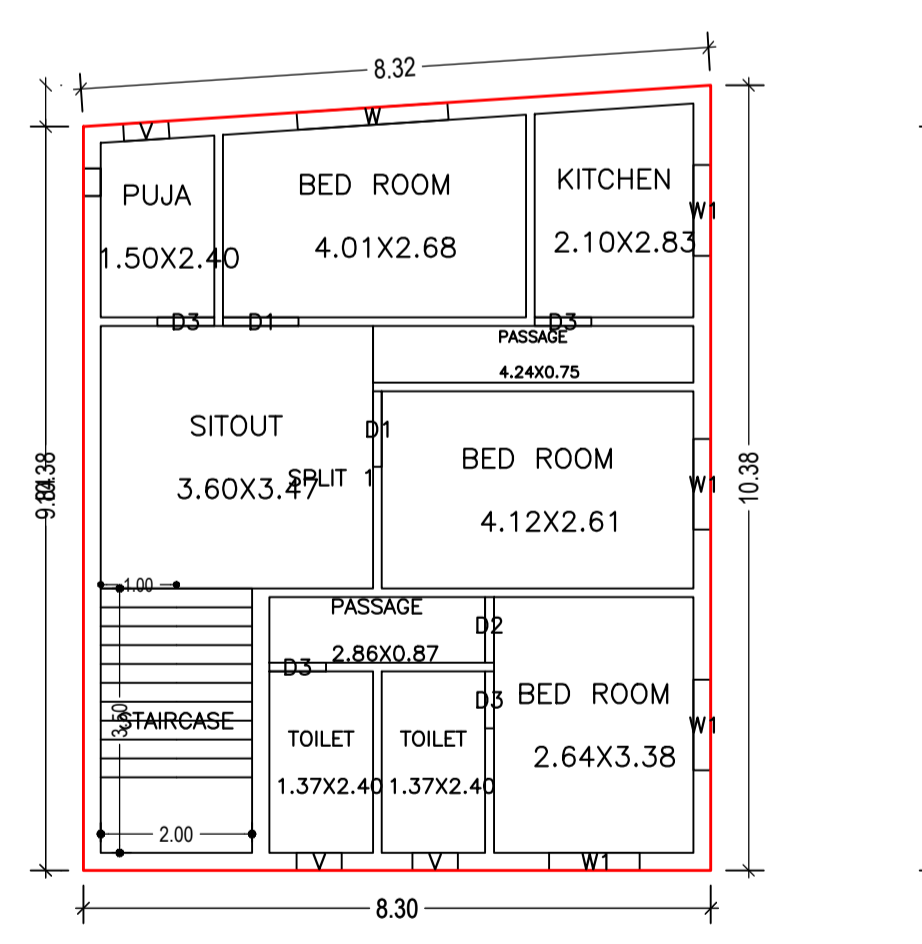
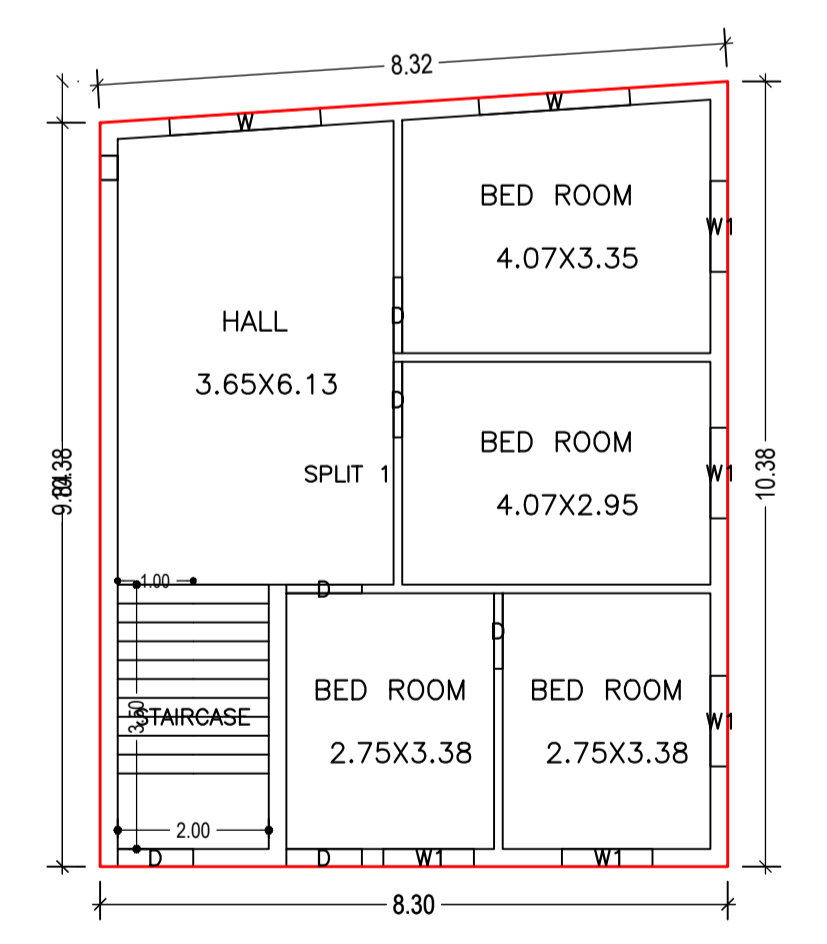
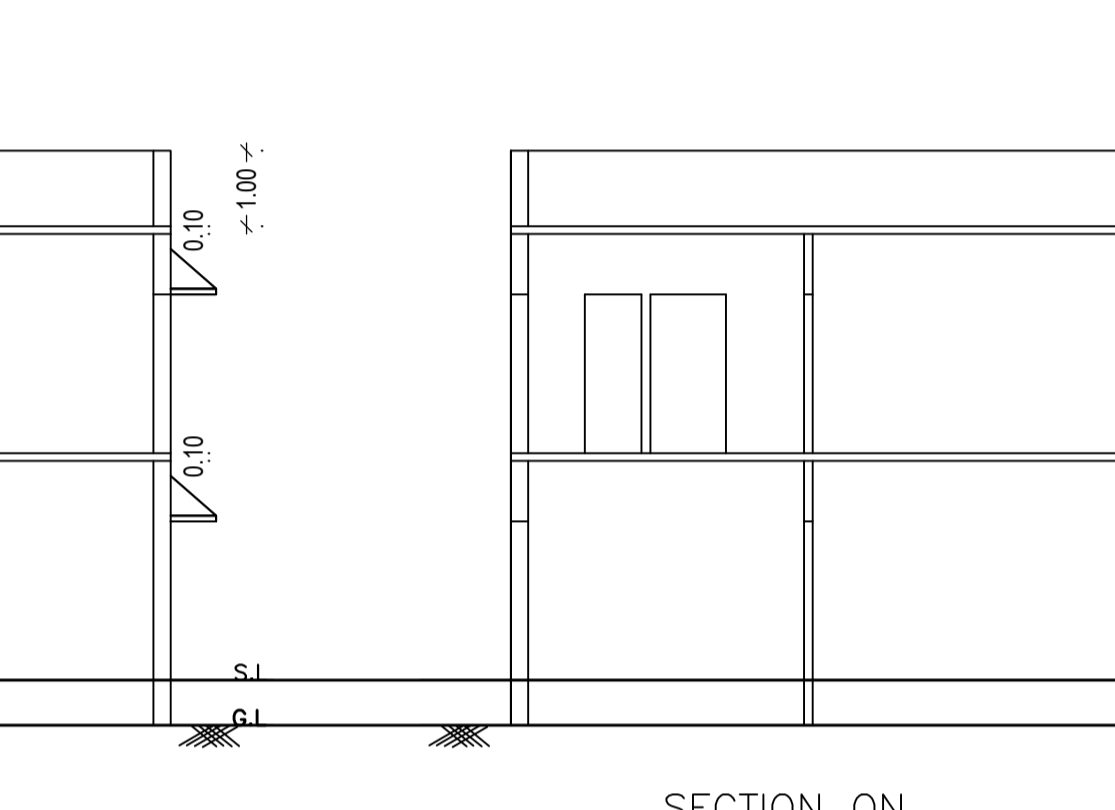
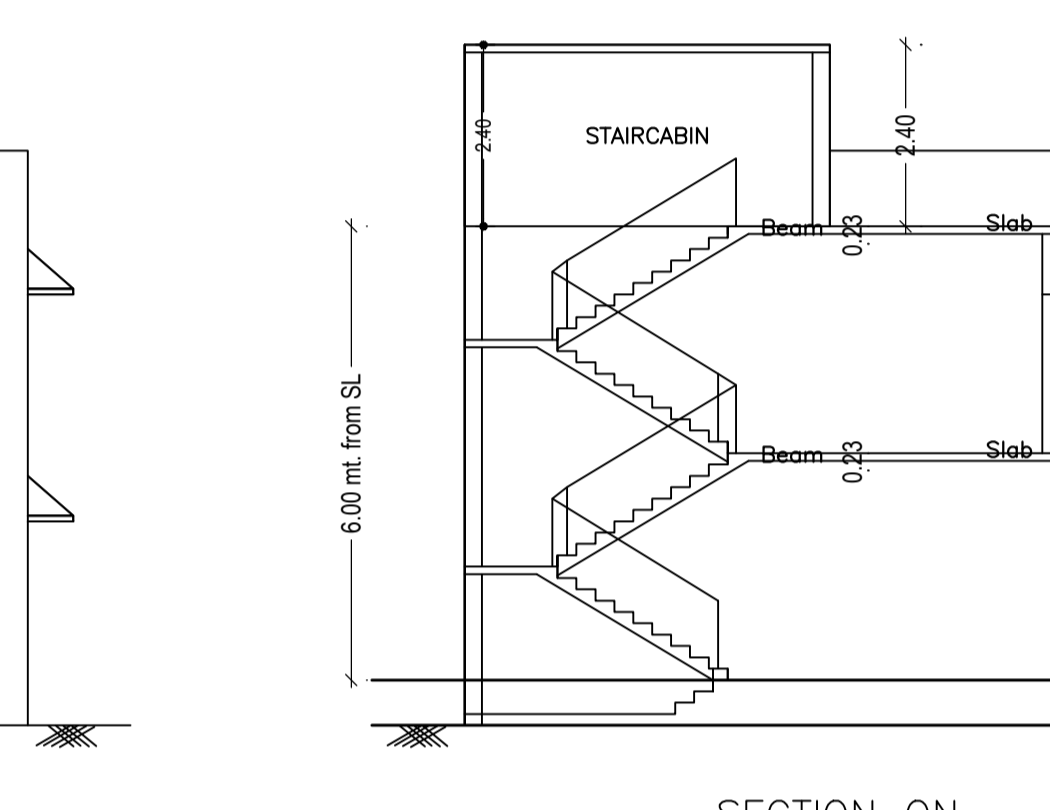
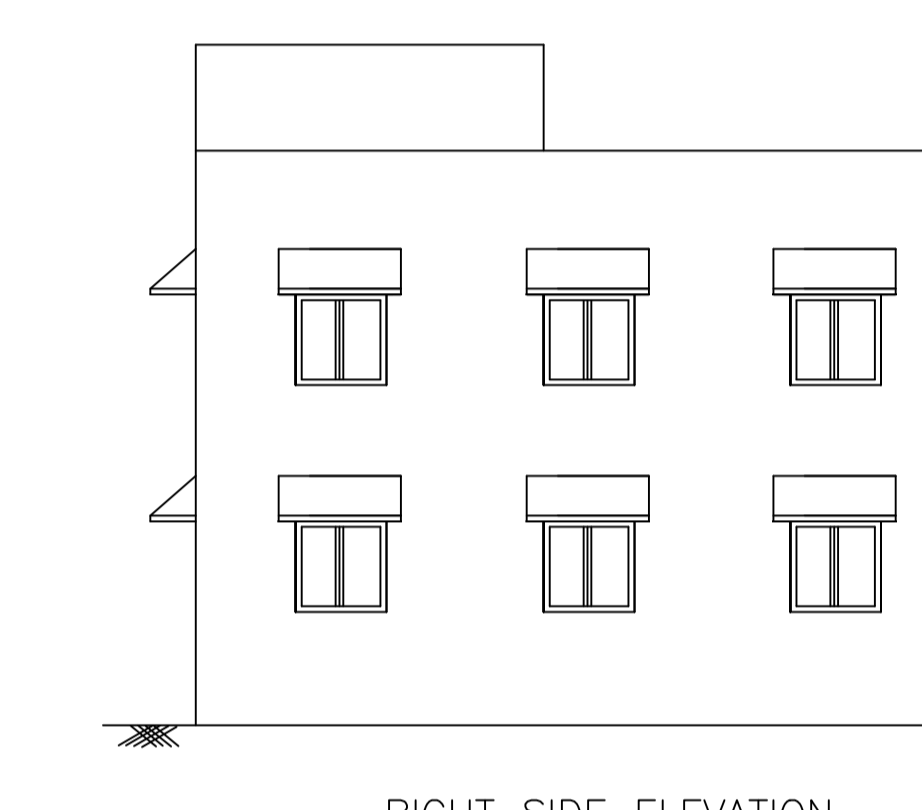
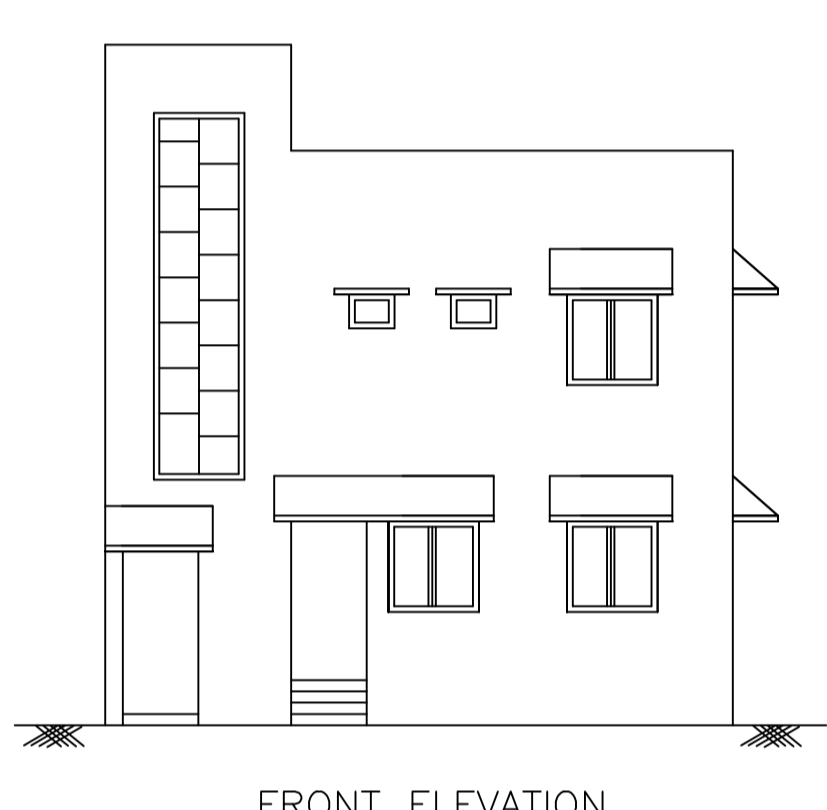
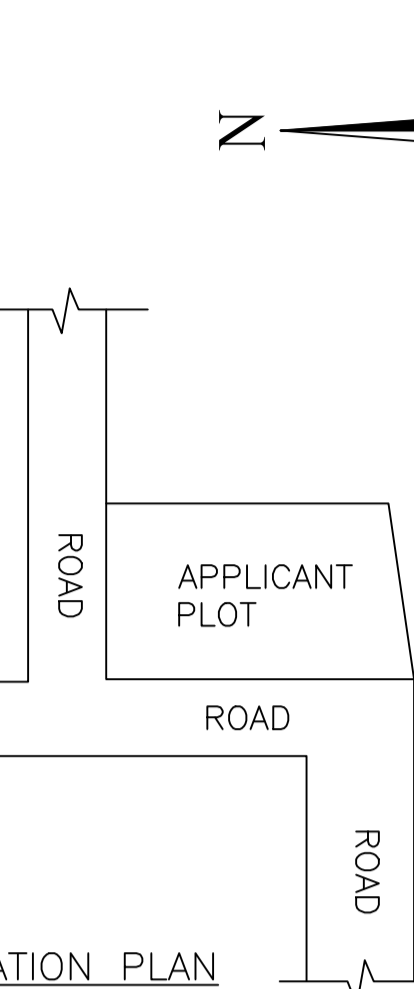
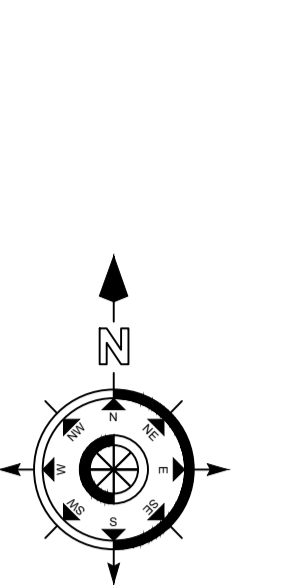
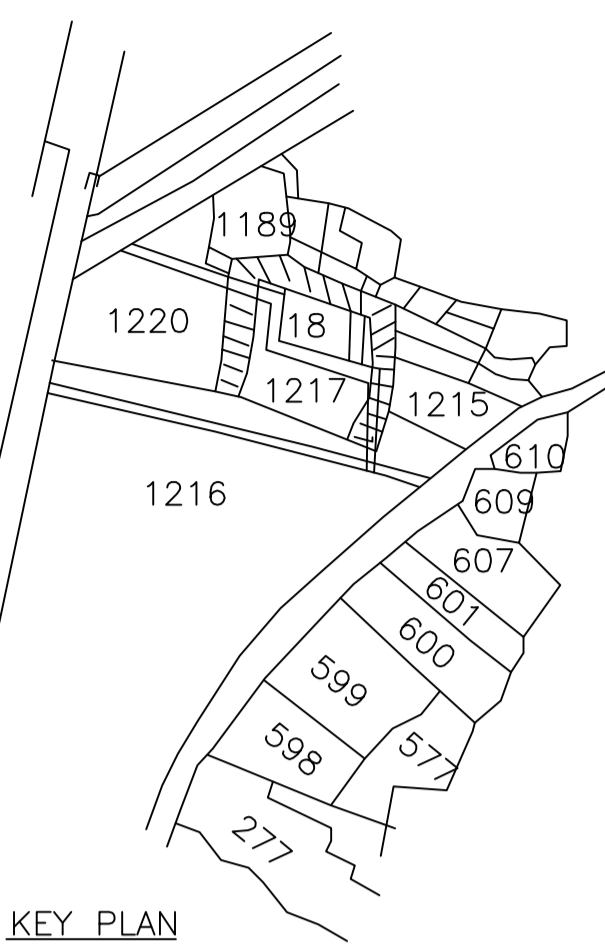
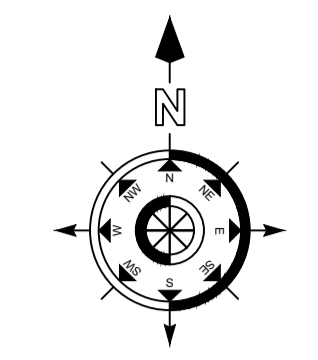
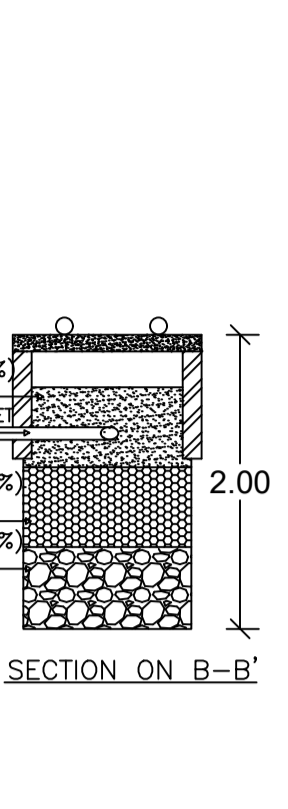
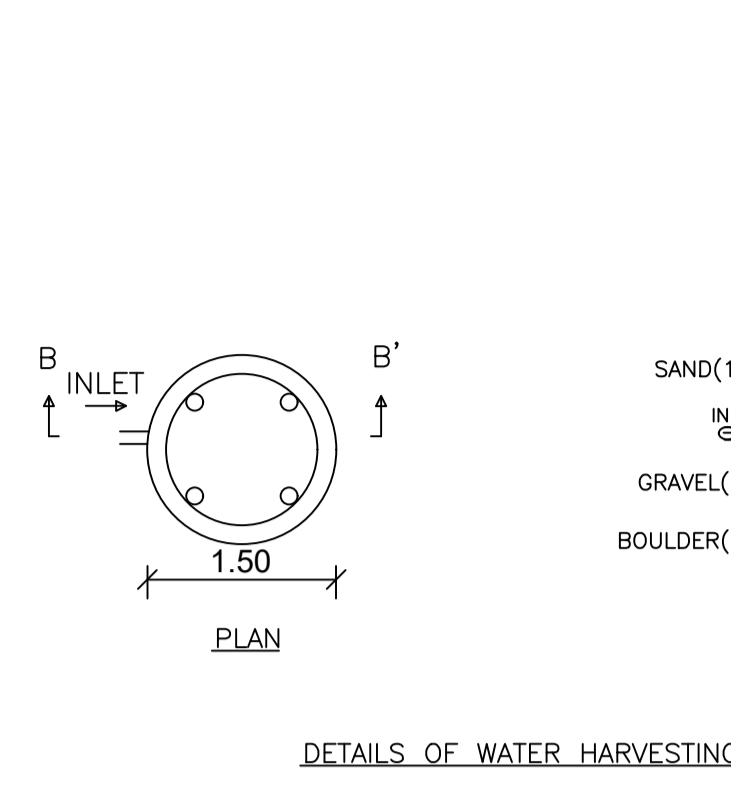
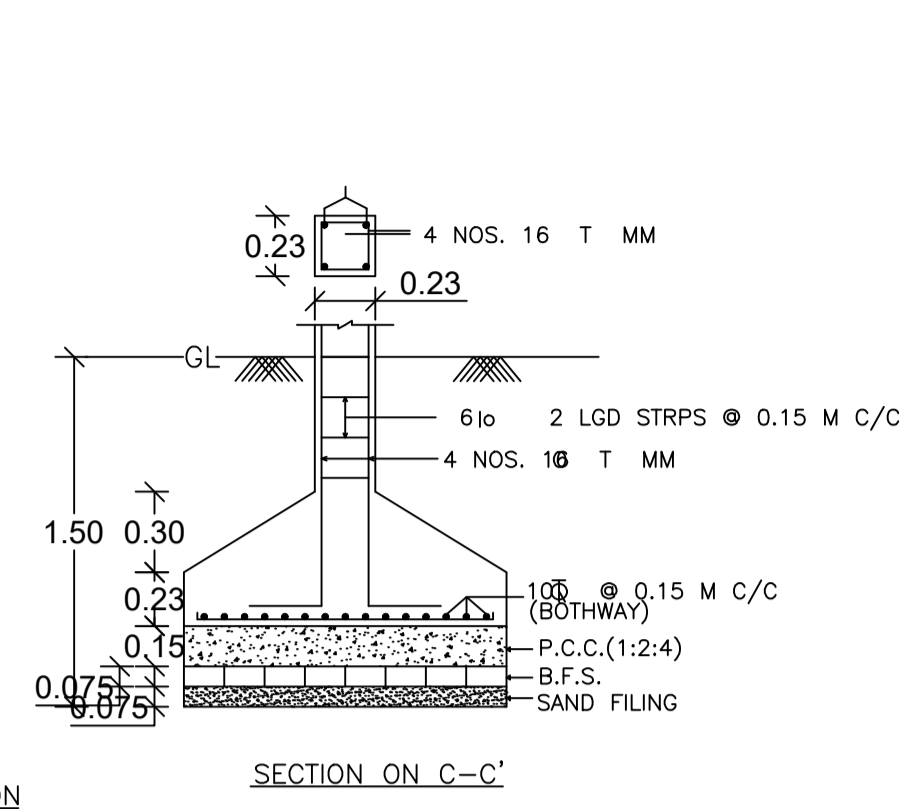
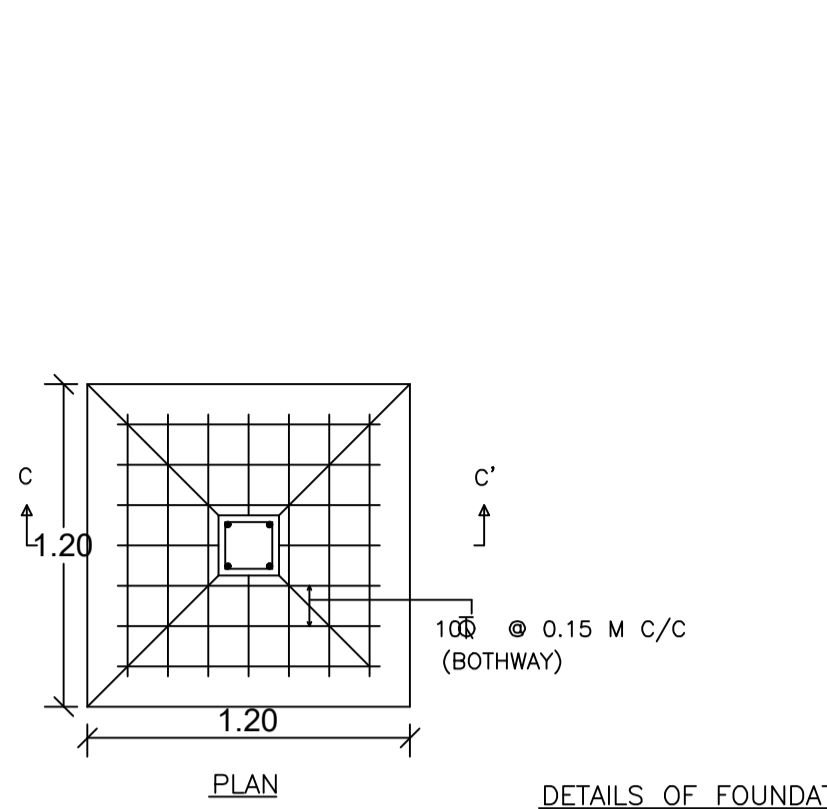

FAR & Tenement Details (Table 4c-1)						
Building	No. of Same Bldg	Total Built Up Area (Sq.mt.)	Proposed FAR Area (Sq.mt.) Resi.	Total FAR Area (Sq.mt.)	Total Consumed Additional FAR Area (Sq.mt.)	Tnmt (No.)
A (RESIDENTIAL)	1	167.82	167.82	167.82	167.82	01
Grand Total :	1	167.82	167.82	167.82	167.82	01

Building USE/SUBUSE Details			
Building Name	Building Use	Building SubUse	Building Structure
A (RESIDENTIAL)	Residential	Bungalow/ Dwelling / Non Apartment	Non-Highrise

COLOR INDEX	
PLOT BOUNDARY	Black
ABUTTING ROAD	Green
PROPOSED CONSTRUCTION	Red
COMMON PLOT	Yellow
ROAD WIDENING AREA	Blue
EXISTING (To be retained)	Orange
EXISTING (To be demolished)	Light Blue

LTP NAME AND SIGNATURE	STRUCTURAL ENG'S NAME AND SIGNATURE	BUILDER NAME AND SIGNATURE	DIGITAL SIGNATURE
RAVI KUMAR CMC/DFTMN/0024/2017			