

Proposal Basic Information

Proposal File No.	CMC/BP/0240/W19/2023
Owner Name	Lakshmi Kumari Das , Pinki Devi
Khata No	730
Plot No	7506
Village Name	Chas
Use	Residential
SubUse	Bungalow/ Dwelling / Non Apartment

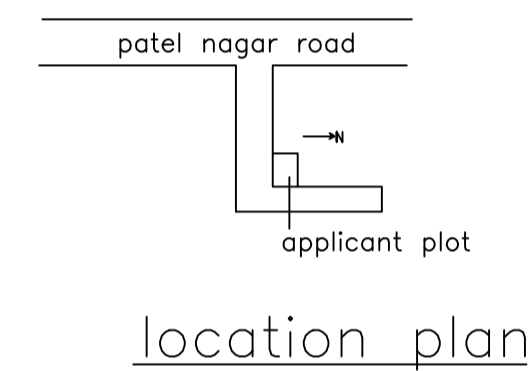
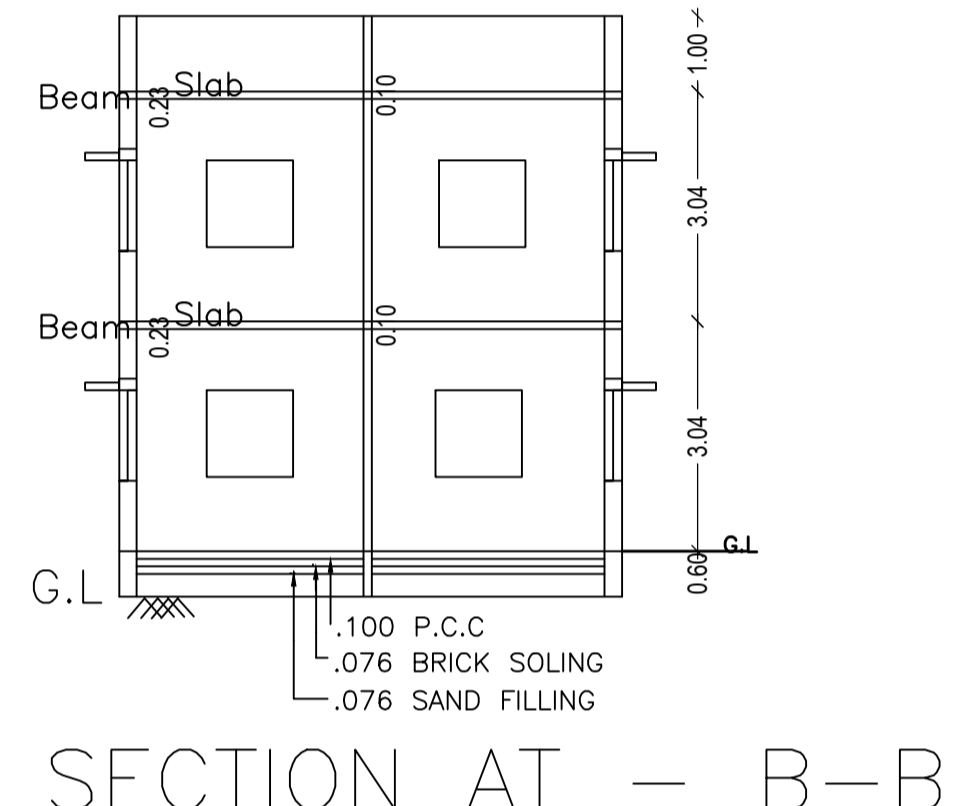
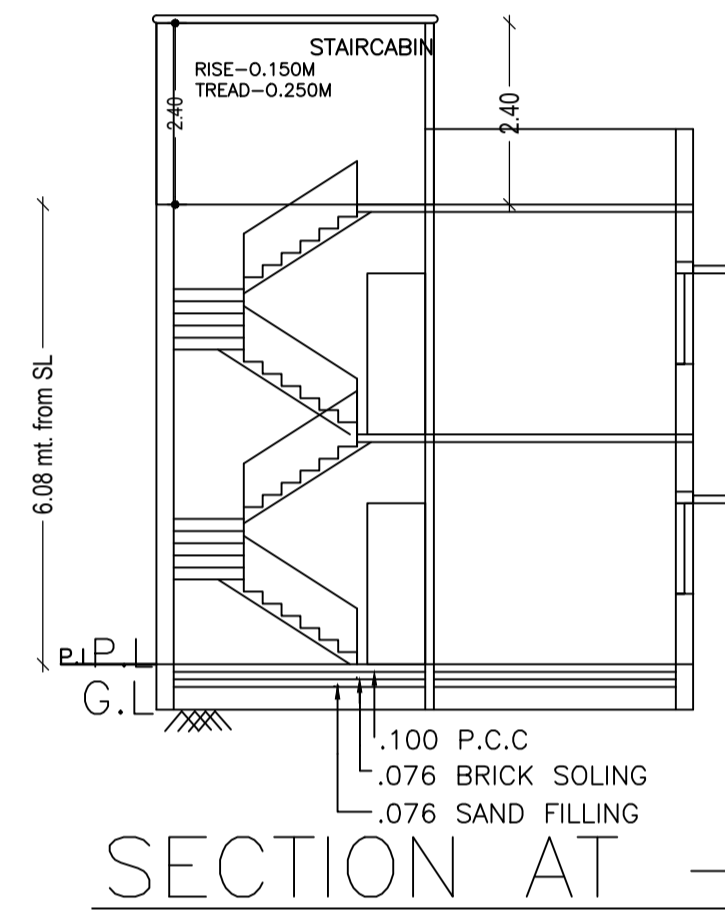
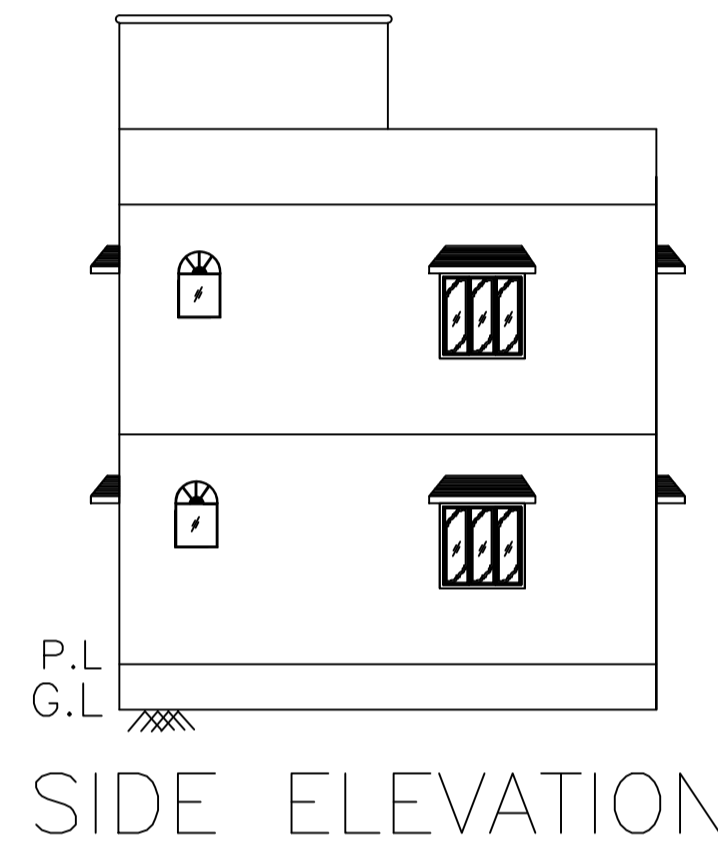
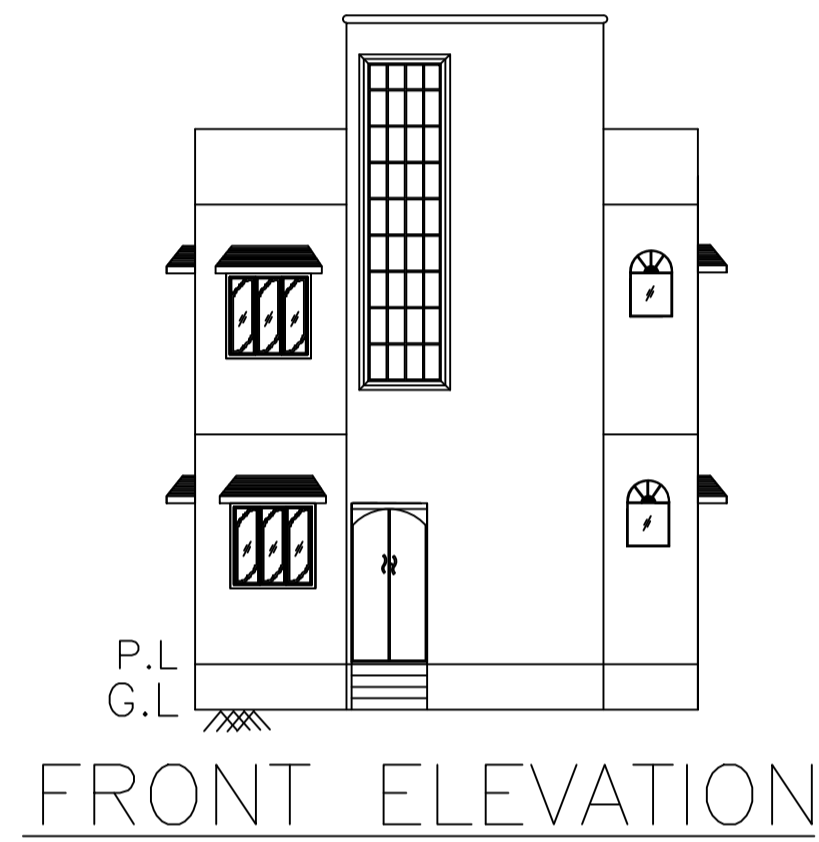
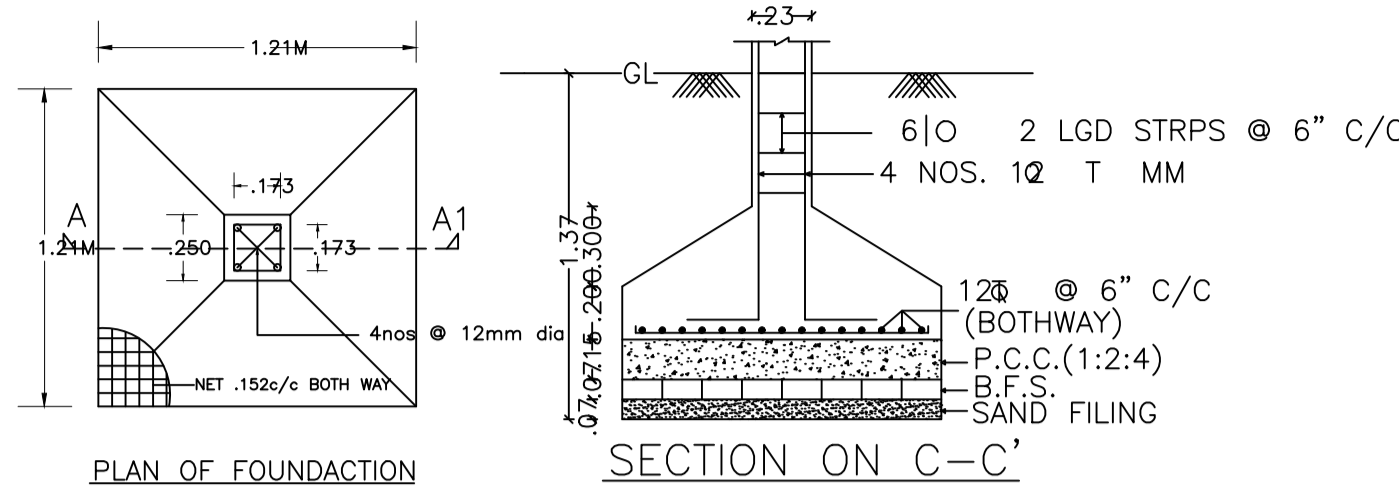
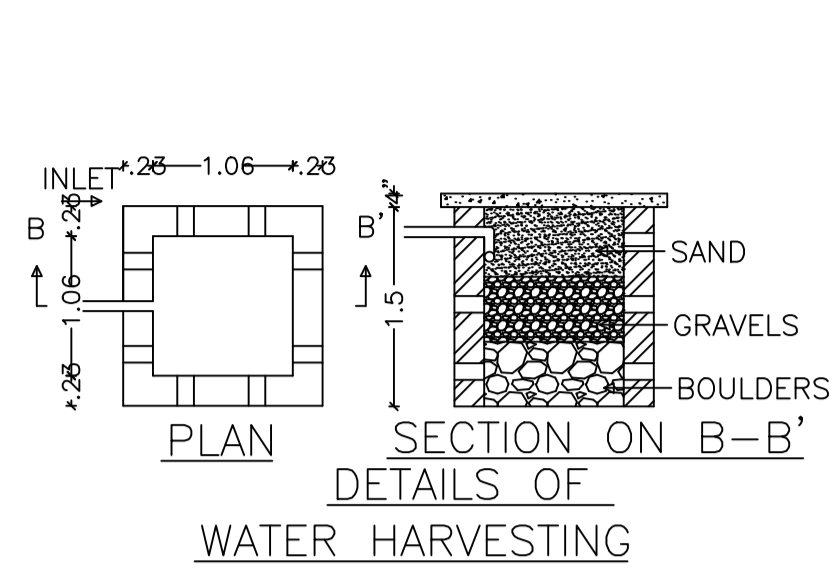
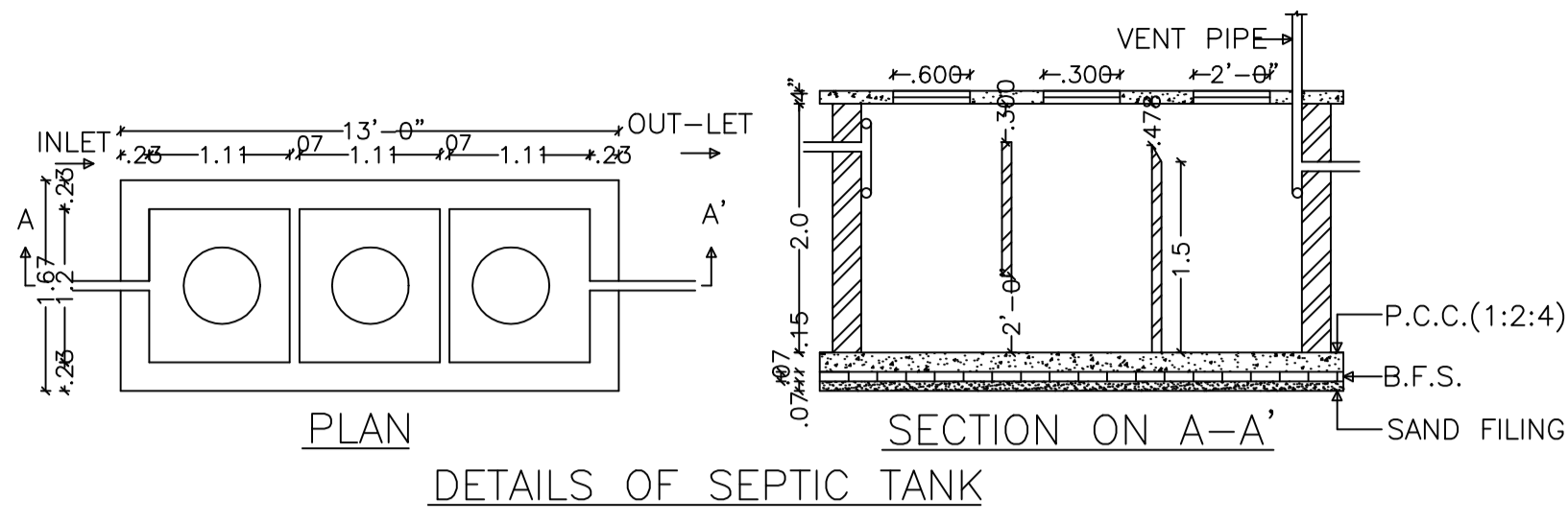

AREA STATEMENT CHAS MUNICIPAL CORPORATION	VERSION NO.: 1.0.66	SQ.MT.
PROJECT DETAIL:	VERSION DATE: 16/10/2020	
Region: JHARKHAND URBAN	Plot Use: Residential	
District: BOKARO	Plot SubUse: Bungalow/ Dwelling / Non Apartment	
Authority: CHAS MUNICIPAL CORPORATION	PlotNearbyReligiousStructure: NA	
Inward No: CMC/BP/0240/W19/2023	Plot/SubPlot No: 7506	
Application Type: General Proposal	North: Plot No. - Devi Das	
Project Type: Building Permission	South: Road Width - 3.0	
Nature of Development: New	East: Road Width - 3.65	
Location of Development Area: Old Area	West: Plot No. - 7506	
AREA OF PLOT (Minimum)	(A)	75.50
NET AREA OF PLOT(Gross Plot Area - Deduction from Gross Plot area)	(A-Deductions)	75.50
Deduction for Balance Plot Area(from Gross Plot Area)		
Common Plot		14.51
Total		14.51
BALANCE AREA OF PLOT(Net Plot Area - Recreational/Amenity space)	(A-Deductions)	60.99
PLOT AREA FOR COVERAGE(Net Plot Area)	(A-Deductions)	75.50
Plot Area for FAR (Net Plot Area + Road Widening Area)	(A-Deductions)	75.50
COVERAGE CHECK		
Permissible Coverage area (70.00 %)		52.85
Proposed Coverage Area (62.54 %)		47.22
Total Prop. Coverage Area (62.54 %)		47.22
Balance coverage area (7.46 %)		5.63
FAR CHECK		
Perm. FAR Area (1.500)		113.25
Total Perm. FAR area		113.25
Residential FAR		94.43
Proposed FAR Area		94.43
Total Proposed FAR Area		94.43
Consumed FAR (Factor)		1.25
Balance FAR Area		18.82
BUILT UP AREA CHECK		
Total Proposed BuiltUp Area		94.44
ARCHITECT (Regd)	Rupendra Kumar Singh	
ENGINEER (Regd)		
SUPERVISOR (Regd)		
OWNER (Regd)	Lakshmi Kumari Das , Pinki Devi	
DEVELOPMENT AUTHORITY LOCAL BODY		

Building :A (LAKSHMI KUMARI DAS)

Floor Name	Total Built Up Area (Sq.mt.)	Proposed FAR Area (Sq.mt.) Resi.	Total FAR Area (Sq.mt.)	Total Consumed Additional FAR Area (Sq.mt.)	Tnmt (No.)
Ground Floor	47.22	47.22	47.22	47.22	01
First Floor	47.22	47.22	47.22	47.22	00
Terrace Floor	0.00	0.00	0.00	0.00	00
Total :	94.44	94.44	94.44	94.44	01
Total Number of Same Buildings :	1				
Total :	94.44	94.44	94.44	94.44	01

Buildingwise Floor FAR Details

Floor Name	Building Name A (LAKSHMI KUMARI DAS)		Total	
	Proposed Built Up Area (Sq.mt.)	Proposed FAR Area (Sq.mt.)	Total Proposed Built Up Area (Sq.mt.)	Total FAR Area (Sq.mt.)
Ground Floor	47.22	47.22	47.22	47.22
First Floor	47.22	47.22	47.22	47.22
Terrace Floor	0.00	0.00	0.00	0.00
Total :	94.44	94.44	94.44	94.44

SCHEDULE OF DOOR:

BUILDING NAME	NAME	LENGTH	HEIGHT	NOS
A (LAKSHMI KUMARI DAS)	D	0.90	2.10	04
A (LAKSHMI KUMARI DAS)	D	0.96	2.10	02
A (LAKSHMI KUMARI DAS)	D	1.00	2.10	02

SCHEDULE OF WINDOW/VENTILATION:

BUILDING NAME	NAME	LENGTH	HEIGHT	NOS
A (LAKSHMI KUMARI DAS)	V	0.60	1.20	04
A (LAKSHMI KUMARI DAS)	W	1.23	1.20	10

Building USE/SUBUSE Details

Building Name	Building Use	Building SubUse	Building Structure
A (LAKSHMI KUMARI DAS)	Residential	Bungalow/ Dwelling / Non Apartment	Non-Highrise

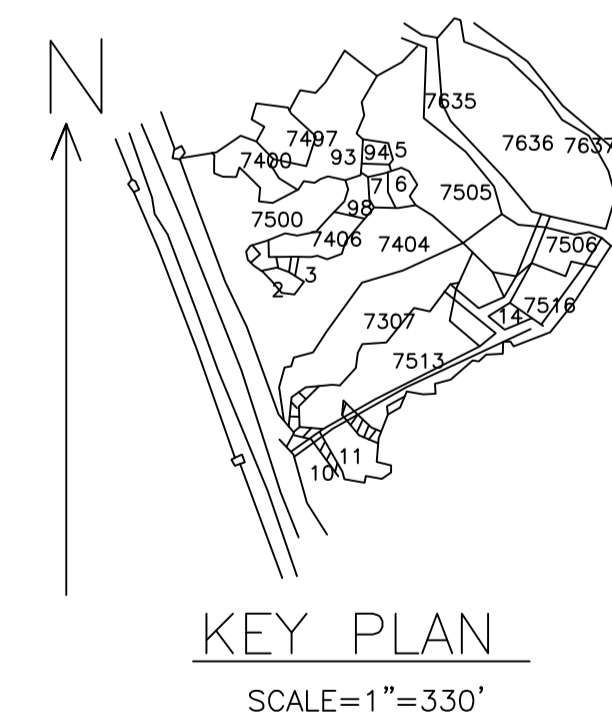
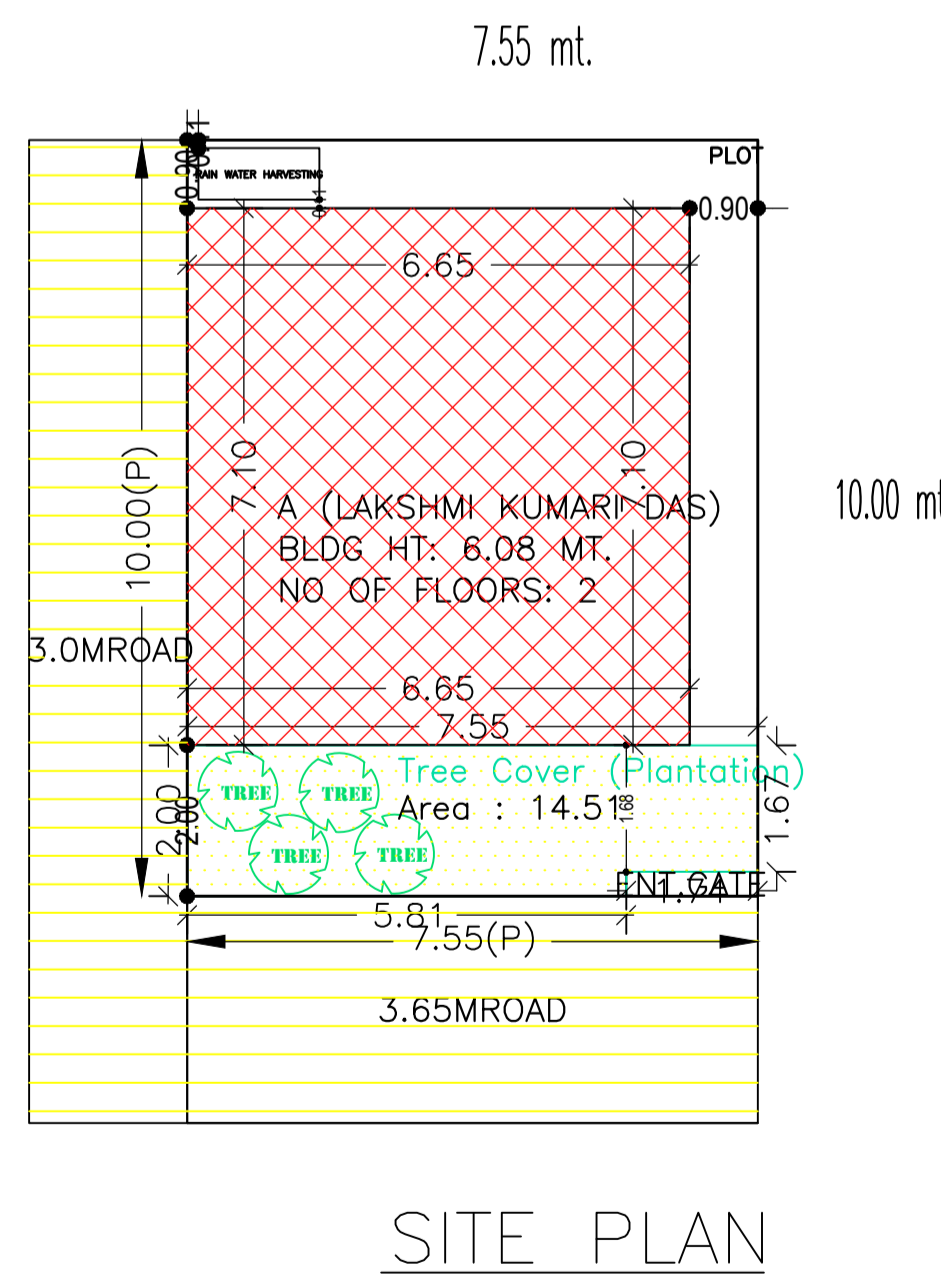
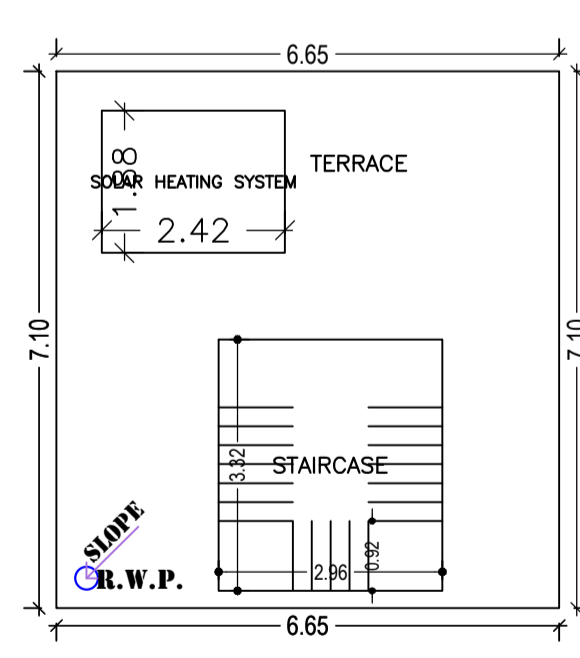
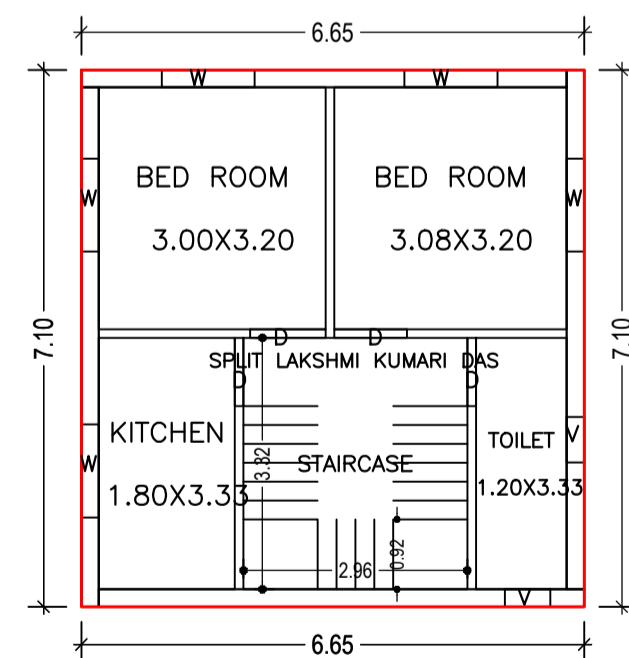
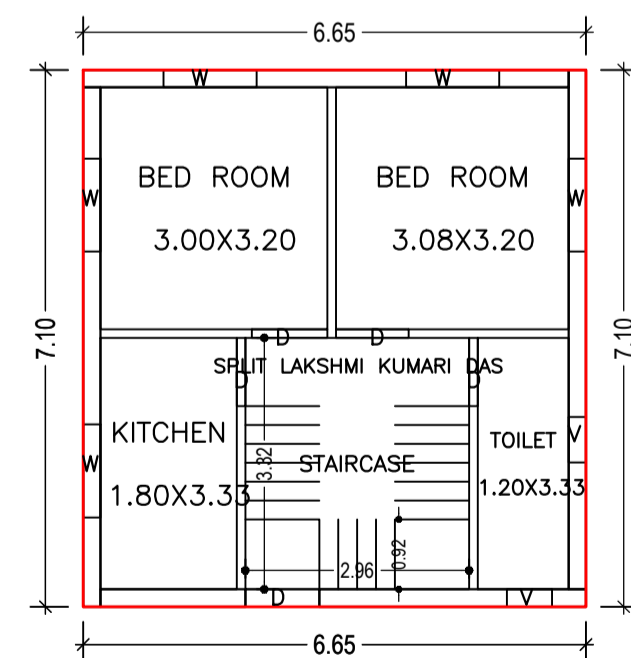

FAR & Tenement Details (Table 4c-1)

Building	No. of Same Bldg	Total Built Up Area (Sq.mt.)	Proposed FAR Area (Sq.mt.) Resi.	Total FAR Area (Sq.mt.)	Total Consumed Additional FAR Area (Sq.mt.)	Tnmt (No.)
A (LAKSHMI KUMARI DAS)	1	94.44	94.44	94.44	94.44	01
Grand Total	1	94.44	94.44	94.44	94.44	01

UnitBUA Table for Building :A (LAKSHMI KUMARI DAS)

FLOOR	Name	UnitBUA Type	UnitBUA Area	Carpet Area	No. of Rooms	No. of Tenement
GROUND FLOOR	SPLIT LAKSHMI KUMARI DAS	FLAT	94.43	82.43	4	1
FIRST FLOOR	SPLIT LAKSHMI KUMARI DAS	FLAT	0.00	0.00	4	0
Total	-	-	94.43	82.43	8	1

COLOR INDEX

- PLOT BOUNDARY
- ABUTTING ROAD
- PROPOSED CONSTRUCTION
- COMMON PLOT
- ROAD WIDENING AREA
- EXISTING (To be retained)
- EXISTING (To be demolished)

LTP NAME AND SIGNATURE

Rupendra Kumar Singh
CMC/ENG/0002/2022

STRUCTURAL ENG'S NAME AND SIGNATURE

BUILDER NAME AND SIGNATURE

DIGITAL SIGNATURE