

Proposal Basic Information

Proposal File No.	CMC/BP/0043/W11/2024
Owner Name	KANCHAN KUMARI
Khata No	72
Plot No	72
Village Name	Chas
Use	Residential
SubUse	Bungalow/ Dwelling / Non Apartment

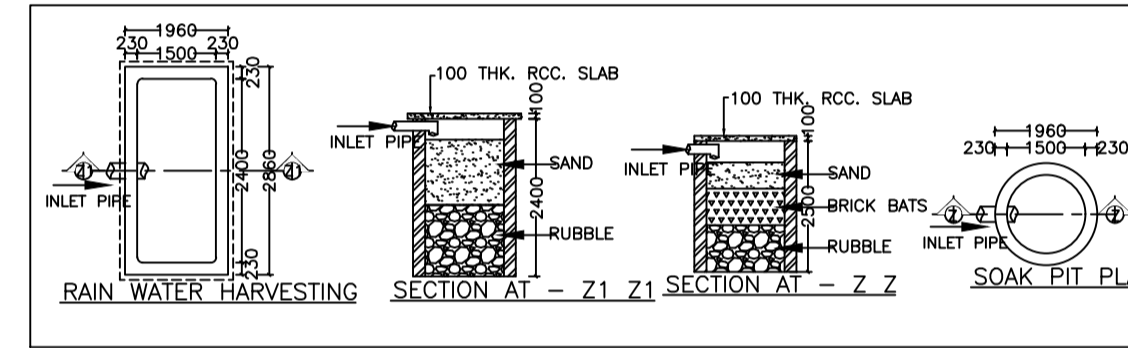

AREA STATEMENT CHAS MUNICIPAL CORPORATION	VERSION NO. : 1.0.70	
PROJECT DETAIL:	VERSION DATE: 16/10/2020	
Region: JHARKHAND URBAN LOCAL BODIES	Plot Use: Residential	
District: BOKARO	Plot SubUse: Bungalow/ Dwelling / Non Apartment	
Authority: CHAS MUNICIPAL CORPORATION	PlotNearby/ReligiousStructure: NA	
Inward_No: CMC/BP/0043/W11/2024	Plot/SubPlot No: 72	
Application Type: General Proposal	North: CTS No. - SALER NUJ	
Project Type: Building Permission	South: Plot No. - 6177.6181	
Nature of Development: New	East: CTS No. - 6172.6181	
Location of Development Area: Old Area	West: CTS No. - ROAD AND SALER PLOT 6181	
AREA DETAILS:		SQ. MT.
AREA OF PLOT (Minimum)	(A)	219.02
NET AREA OF PLOT(Gross Plot Area - Deduction from Gross Plot area)	(A-Deductions)	219.02
Deduction for Balance Plot Area(from Gross Plot Area)		
Common Plot		67.57
Total		67.57
BALANCE AREA OF PLOT(Net Plot Area - Recreational/Amenity space)	(A-Deductions)	151.45
PLOT AREA FOR COVERAGE(Net Plot Area)	(A-Deductions)	219.02
Plot Area for FAR (Net Plot Area + Road/Widening Area)	(A-Deductions)	219.02
COVERAGE CHECK		
Permissible Coverage area (70.00 %)		153.31
Proposed Coverage Area (53.31 %)		116.76
Total Prop. Coverage Area (53.31 %)		116.76
Balance coverage area (16.69 %)		36.55
FAR CHECK		
Perm. FAR Area (1.500)		328.53
Total Perm. FAR area		328.53
Residential FAR		233.52
Proposed FAR Area		233.52
Total Proposed FAR Area		233.52
Consumed FAR (Factor)		1.07
Balance FAR Area		95.01
BUILT UP AREA CHECK		
Total Proposed BuiltUp Area		233.52
ARCHITECT (Regd)		Mukesh Kumar
ENGINEER (Regd)		
SUPERVISOR (Regd)		
OWNER (Regd)		KANCHAN KUMARI
DEVELOPMENT AUTHORITY		LOCAL BODY

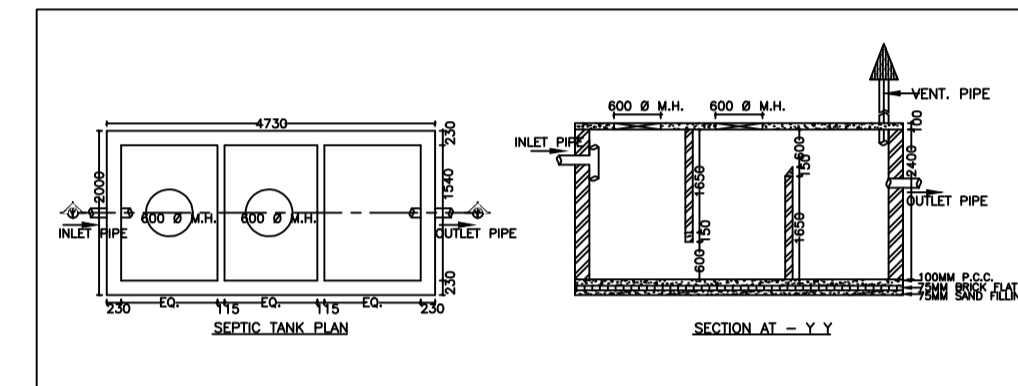
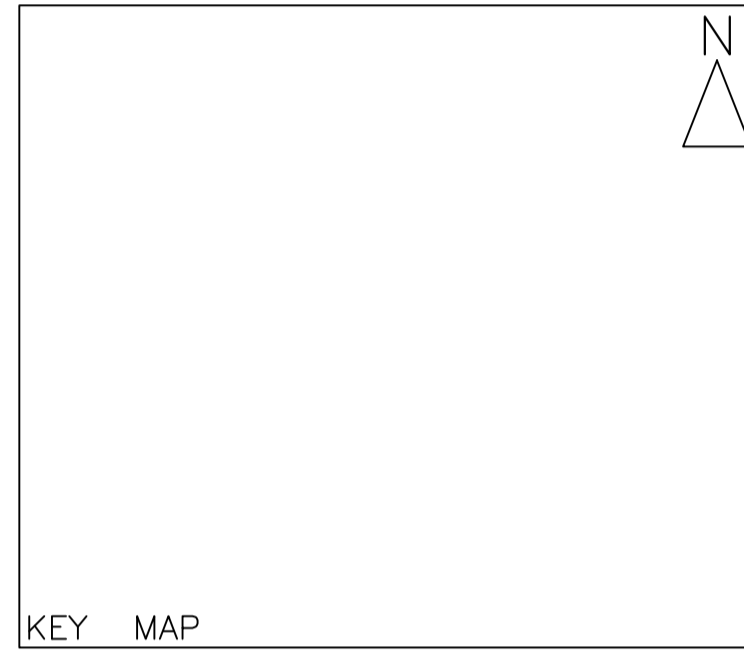
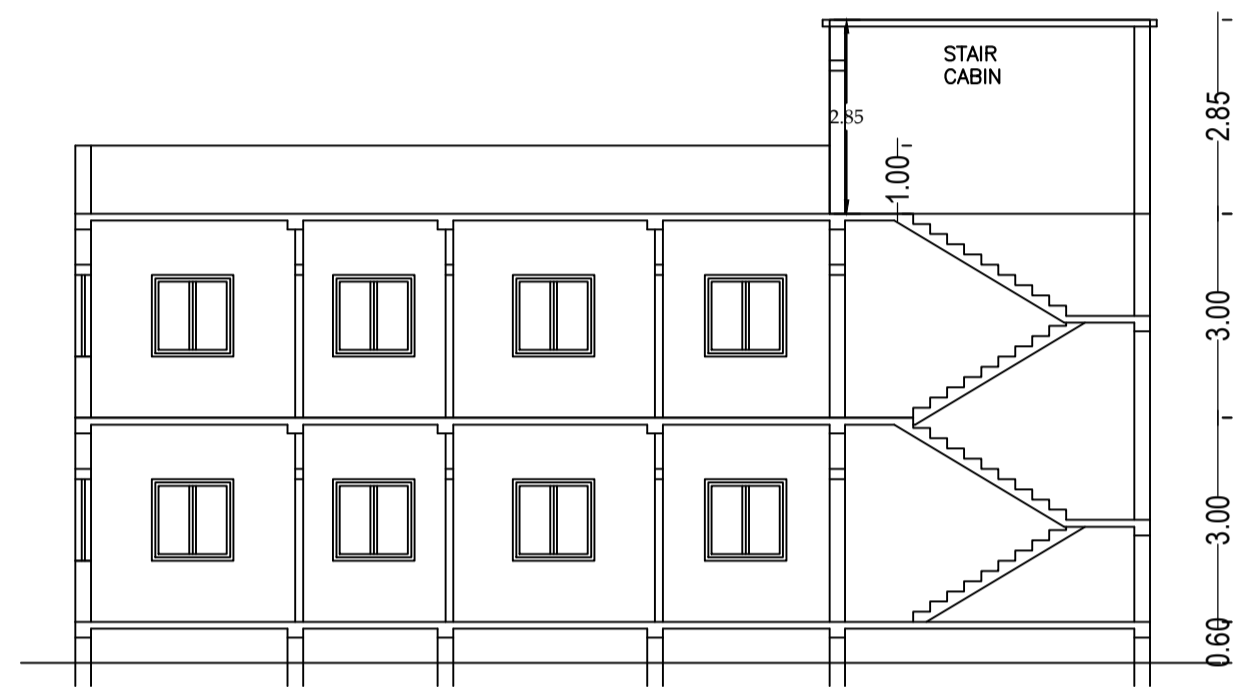
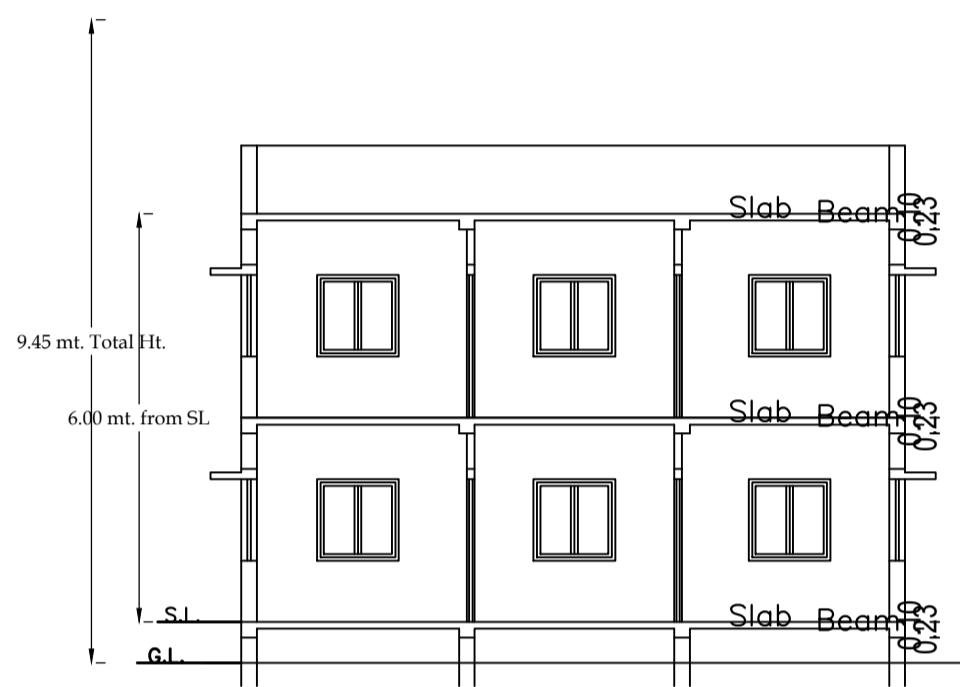
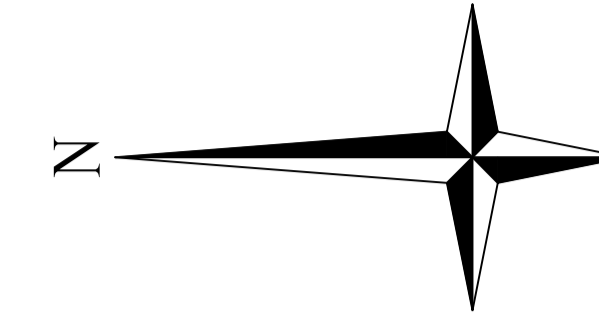
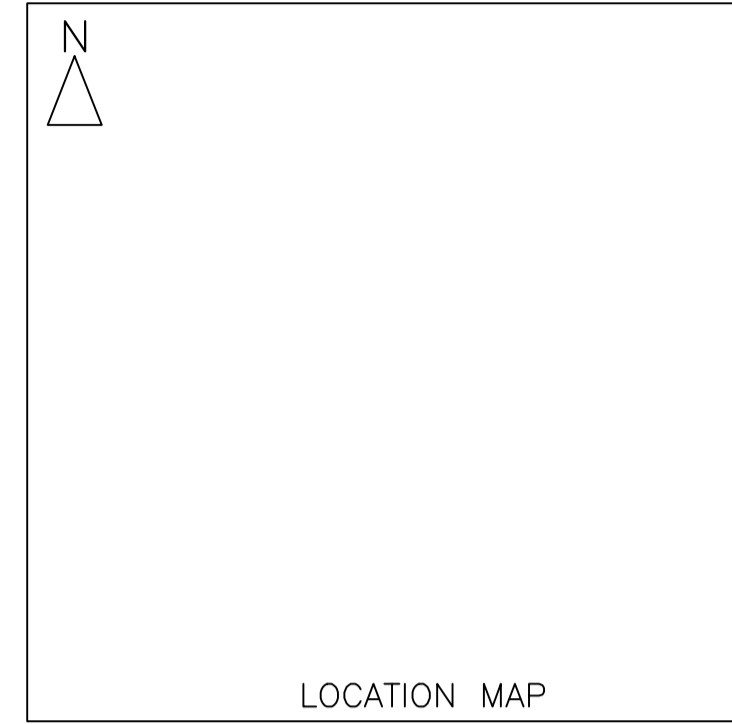
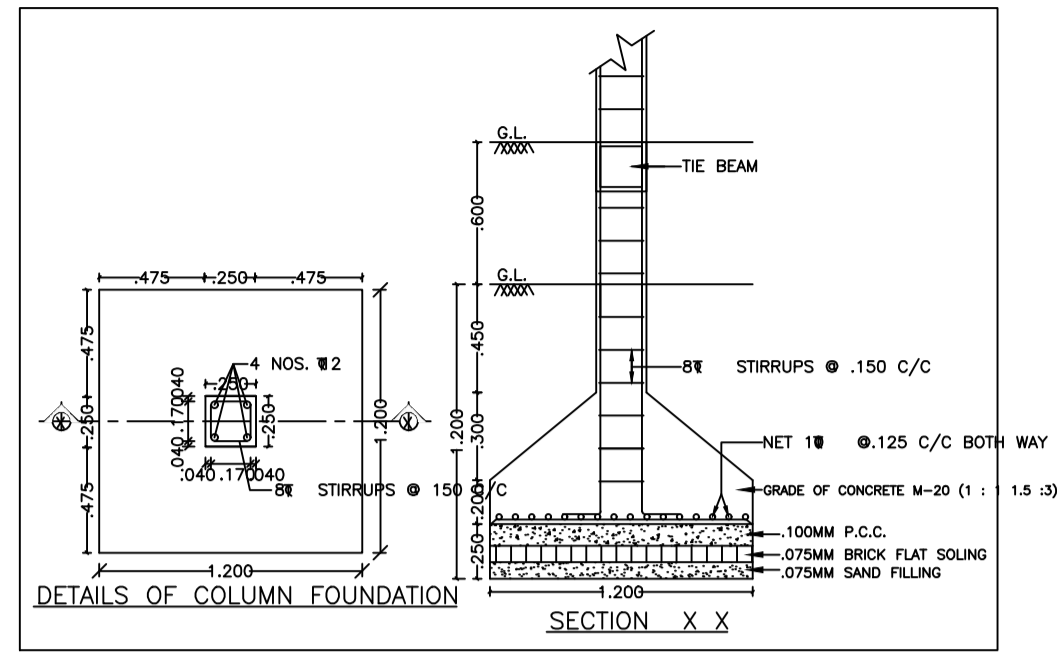
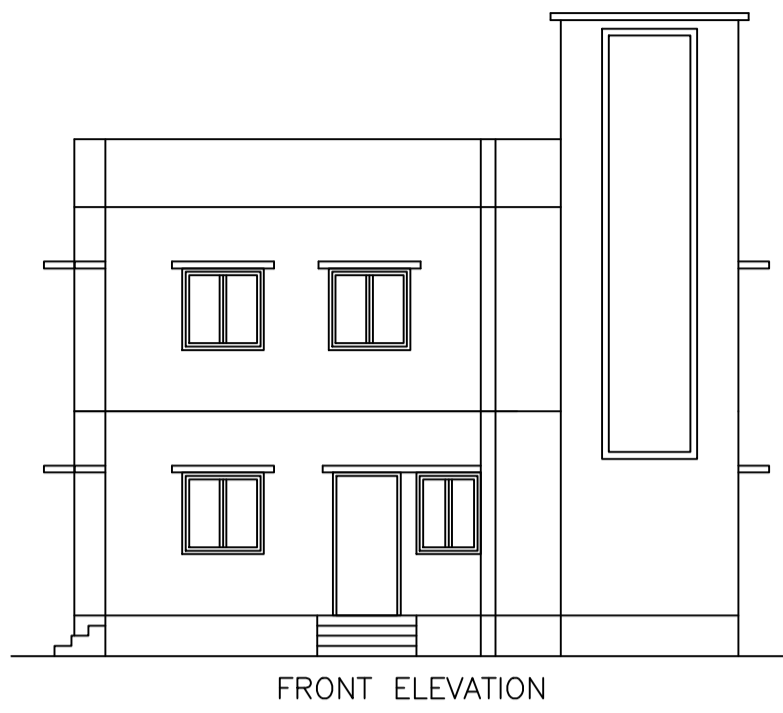
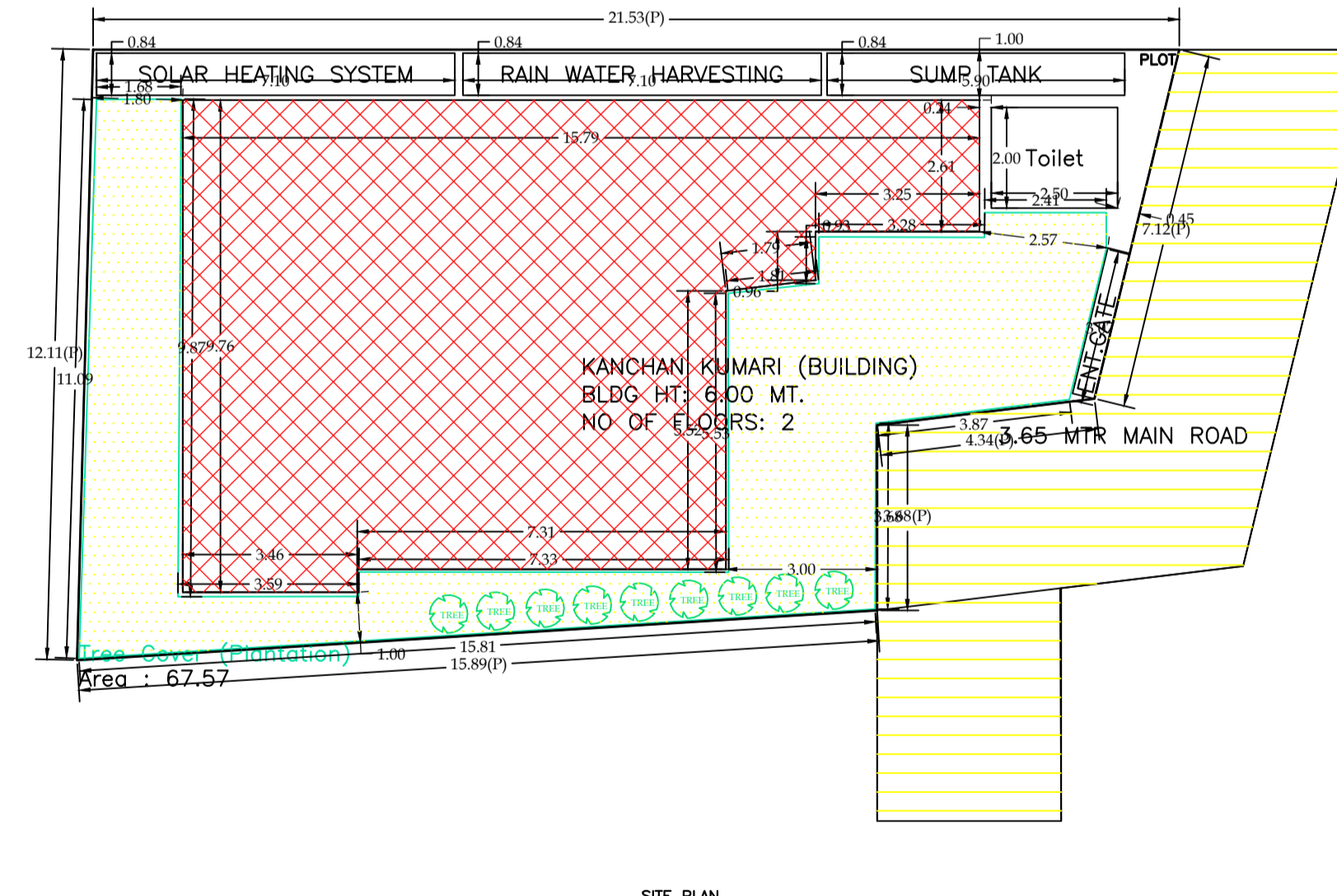
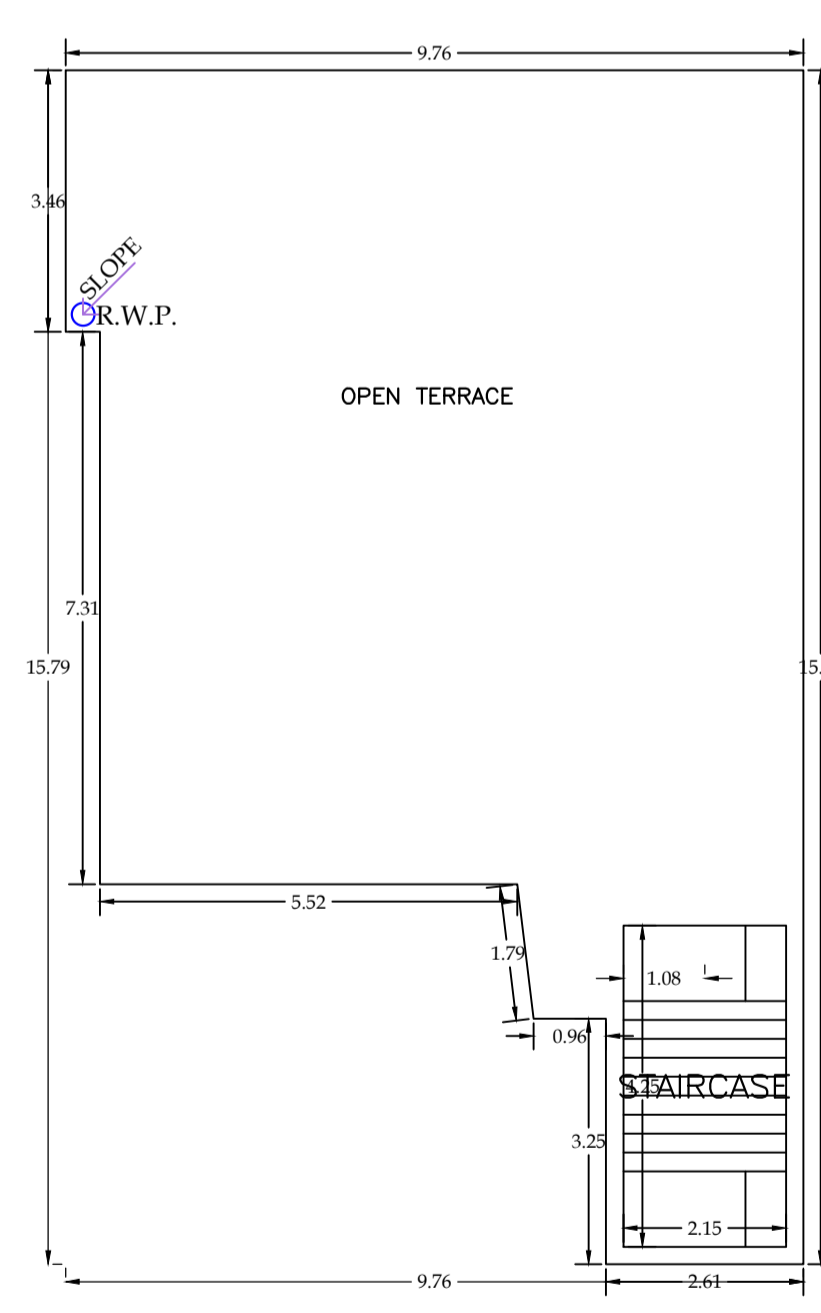
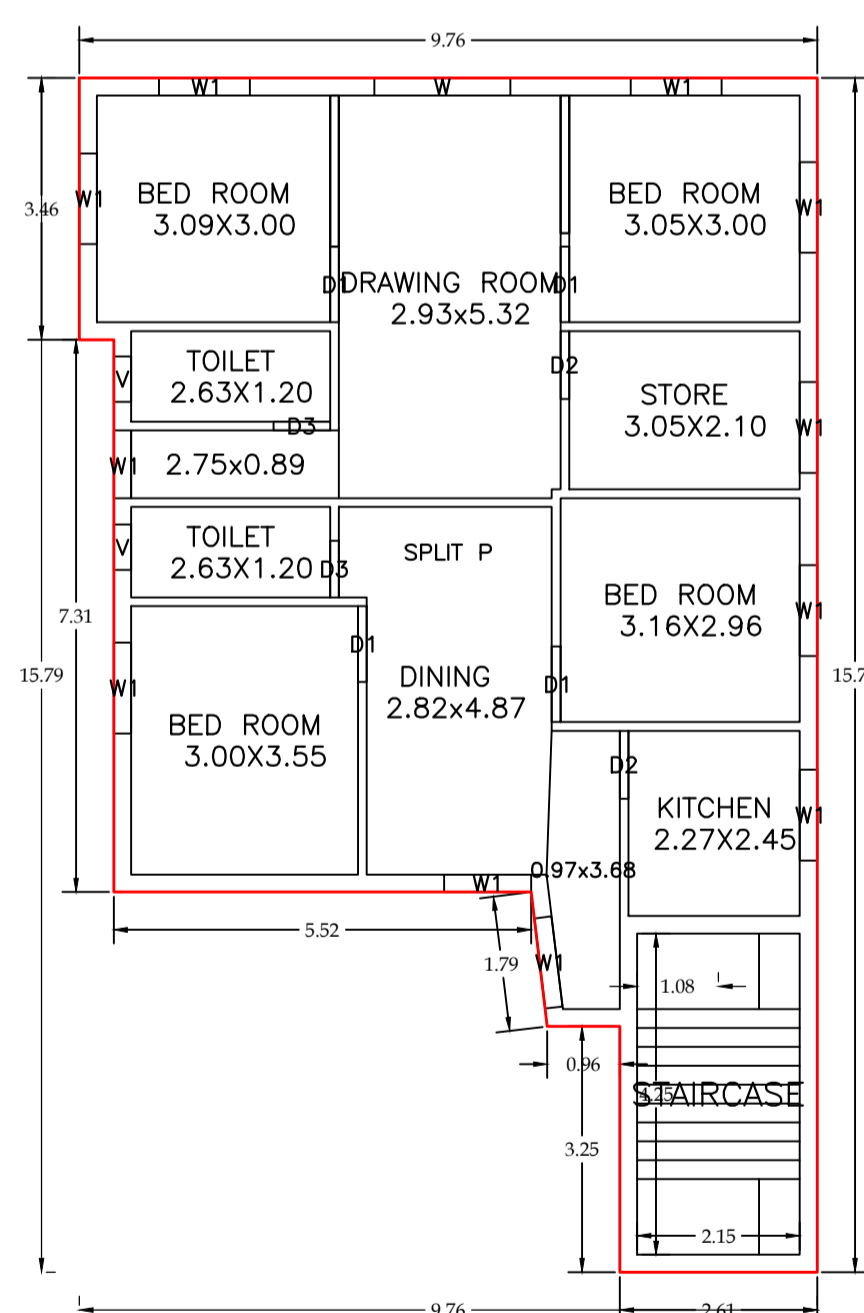
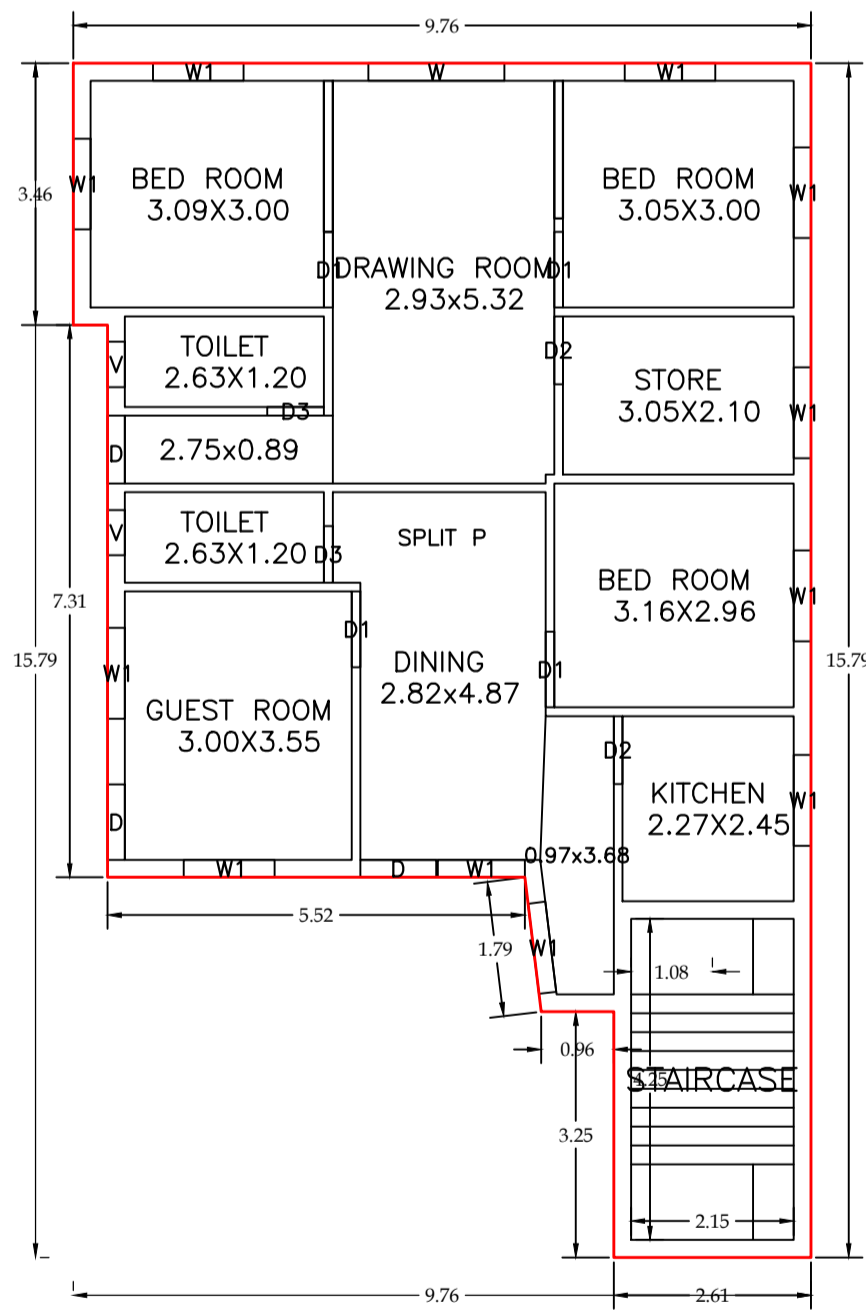

SCHEDULE OF DOOR:

BUILDING NAME	NAME	LENGTH	HEIGHT	NOS
KANCHAN KUMARI (BUILDING)	D3	0.75	2.10	04
KANCHAN KUMARI (BUILDING)	D2	0.90	2.10	04
KANCHAN KUMARI (BUILDING)	D	0.90	2.10	01
KANCHAN KUMARI (BUILDING)	D1	1.00	2.10	08
KANCHAN KUMARI (BUILDING)	D	1.00	2.10	02

SCHEDULE OF WINDOW/VENTILATION:

BUILDING NAME	NAME	LENGTH	HEIGHT	NOS
KANCHAN KUMARI (BUILDING)	V	0.60	0.90	04
KANCHAN KUMARI (BUILDING)	W1	0.90	1.20	01
KANCHAN KUMARI (BUILDING)	W1	1.15	1.20	02
KANCHAN KUMARI (BUILDING)	W1	1.20	1.20	19
KANCHAN KUMARI (BUILDING)	W	1.80	1.20	02

Building :KANCHAN KUMARI (BUILDING)

Floor Name	Total Built Up Area (Sq.mt.)	Proposed FAR Area (Sq.mt.) Res.	Total FAR Area (Sq.mt.)	Total Consumed Additional FAR Area (Sq.mt.)	Trmt (No.)
Ground Floor	116.76	116.76	116.76	116.76	01
First Floor	116.76	116.76	116.76	116.76	00
Terrace Floor	0.00	0.00	0.00	0.00	00
Total	233.52	233.52	233.52	233.52	01
Total Number of Same Buildings	1				
Total :	233.52	233.52	233.52	233.52	01

UnitBUA Table for Building :KANCHAN KUMARI (BUILDING)

FLOOR	Name	UnitBUA Type	UnitBUA Area	Carpet Area	No. of Rooms	No. of Tenement
GROUND FLOOR PLAN	SPLIT P	FLAT	190.70	189.82	10	1
FIRST FLOOR PLAN	SPLIT P	FLAT	0.00	0.00	10	0
Total:	-	-	190.70	189.82	20	1

Buildingwise Floor FAR Details

Floor Name	KANCHAN KUMARI (BUILDING)		Total	
	Proposed Built Up Area (Sq.mt.)	Proposed FAR Area (Sq.mt.)	Total Proposed Built Up Area (Sq.mt.)	Total FAR Area (Sq.mt.)
Ground Floor	116.76	116.76	116.76	116.76
First Floor	116.76	116.76	116.76	116.76
Terrace Floor	0.00	0.00	0.00	0.00
Total :	233.52	233.52	233.52	233.52

FAR & Tenement Details (Table 4c-1)

Building	No. of Same Bldg	Total Built Up Area (Sq.mt.)	Proposed FAR Area (Sq.mt.) Res.	Total FAR Area (Sq.mt.)	Total Consumed Additional FAR Area (Sq.mt.)	Trmt (No.)
KANCHAN KUMARI (BUILDING)	1	233.52	233.52	233.52	233.52	01
Grand Total :	1	233.52	233.52	233.52	233.52	01

Building USE/SUBUSE Details

Building Name	Building Use	Building SubUse	Building Structure
KANCHAN KUMARI (BUILDING)	Residential	Bungalow/ Dwelling / Non Apartment	Non-Highrise

COLOR INDEX

PLOT BOUNDARY	Black
ABUTTING ROAD	Green
PROPOSED CONSTRUCTION	Red
COMMON PLOT	Yellow
ROAD WIDENING AREA	Blue
EXISTING (To be retained)	Light Blue
EXISTING (To be demolished)	Dark Blue

LTP NAME AND SIGNATURE	STRUCTURAL ENG'S NAME AND SIGNATURE	BUILDER NAME AND SIGNATURE	DIGITAL SIGNATURE
Mukesh Kumar CMC/ENG/0004/2017			