

Proposal Basic Information

Proposal File No.	CMC/BP/0053/W07/2024
Owner Name	SHRI AMAN KUMAR AND SHRI AMIT KUMAR
Khata No.	27
Plot No.	2185
Village Name	Chas
Use	Residential
SubUse	Bungalow/ Dwelling / Non Apartment

AREA STATEMENT CHAS MUNICIPAL CORPORATION	VERSION NO. : 1.0.70
PROJECT DETAIL:	VERSION DATE: 16/10/2020
Region: JHARKHAND URBAN LOCAL BODIES	Plot Use: Residential
District: BOKARO	Plot SubUse: Bungalow/ Dwelling / Non Apartment
Authority: CHAS MUNICIPAL CORPORATION	PlotNearby/ReligiousStructure: NA
Inward_No: CMC/BP/0053/W07/2024	Plot/Plot No: 2185
Application Type: General Proposal	North: Plot No. - PLOTING NO-C/1
Project Type: Building Permission	South: Plot No. - PLOTING NO-C/3
Nature of Development: New	East: Road Width - 6.09 MTR
Location of Development Area: Old Area	West: Plot No. - PLOTING NO-B/2
AREA DETAILS:	SQ. MT.
AREA OF PLOT (Minimum)	202.30
NET AREA OF PLOT(Gross Plot Area - Deduction from Gross Plot area)	202.30
Deduction for Balance Plot Area(from Gross Plot Area)	
Common Plot	10.13
Total	10.13
BALANCE AREA OF PLOT(Net Plot Area - Recreational/Amenity space)	192.17
PLOT AREA FOR COVERAGE(Net Plot Area)	202.30
Plot Area for FAR (Net Plot Area + Road Widening Area)	202.30
COVERAGE CHECK	
Permissible Coverage area ( 70.00 % )	141.61
Proposed Coverage Area ( 63.65 % )	128.76
Total Prop. Coverage Area ( 63.65 % )	128.76
Balance coverage area ( 6.35 % )	12.85
FAR CHECK	
Perm. FAR Area ( 1.800 )	364.14
Total Perm. FAR area	364.14
Residential FAR	237.88
Proposed FAR Area	237.88
Total Proposed FAR Area	237.88
Consumed FAR (Factor)	1.18
Balance FAR Area	126.26
BUILT UP AREA CHECK	
Total Proposed BuiltUp Area	245.58
ARCHITECT (Regd)	SUBHASH NARHARRAO NETRAGAONKAR
ENGINEER (Regd)	
SUPERVISOR (Regd)	
OWNER (Regd)	SHRI AMAN KUMAR AND SHRI AMIT KUMAR
DEVELOPMENT AUTHORITY	LOCAL BODY



FRONT SIDE ELEVATION

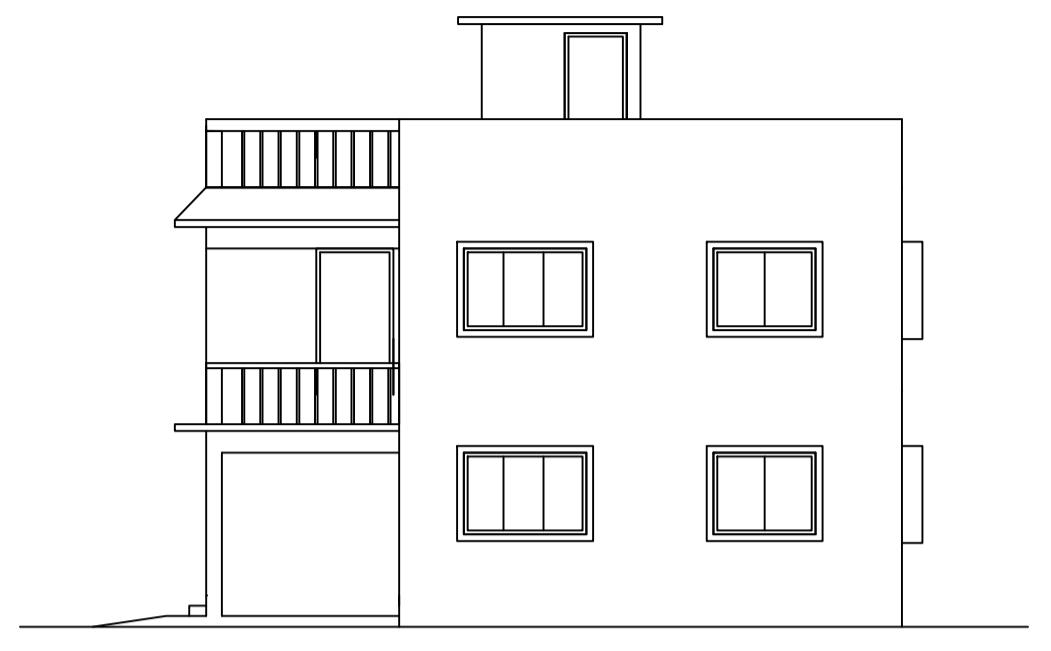

RIGHT SIDE ELEVATION

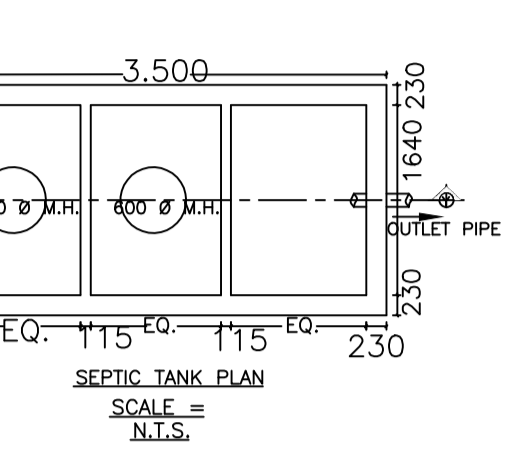
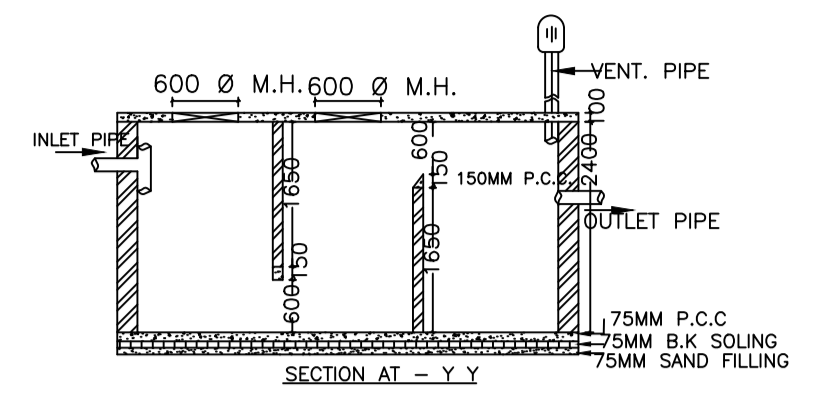

SCALE = 1/10

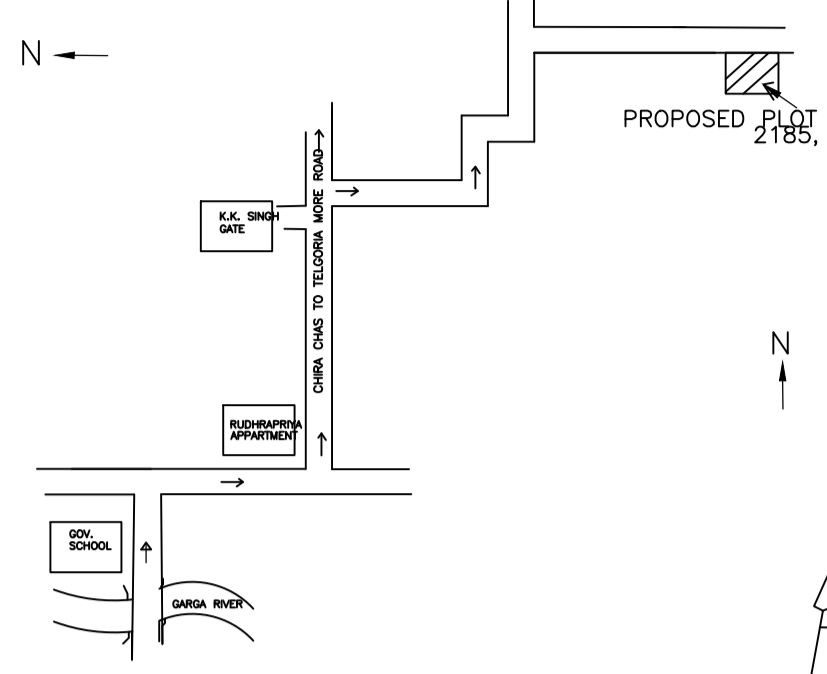

KEY PLAN

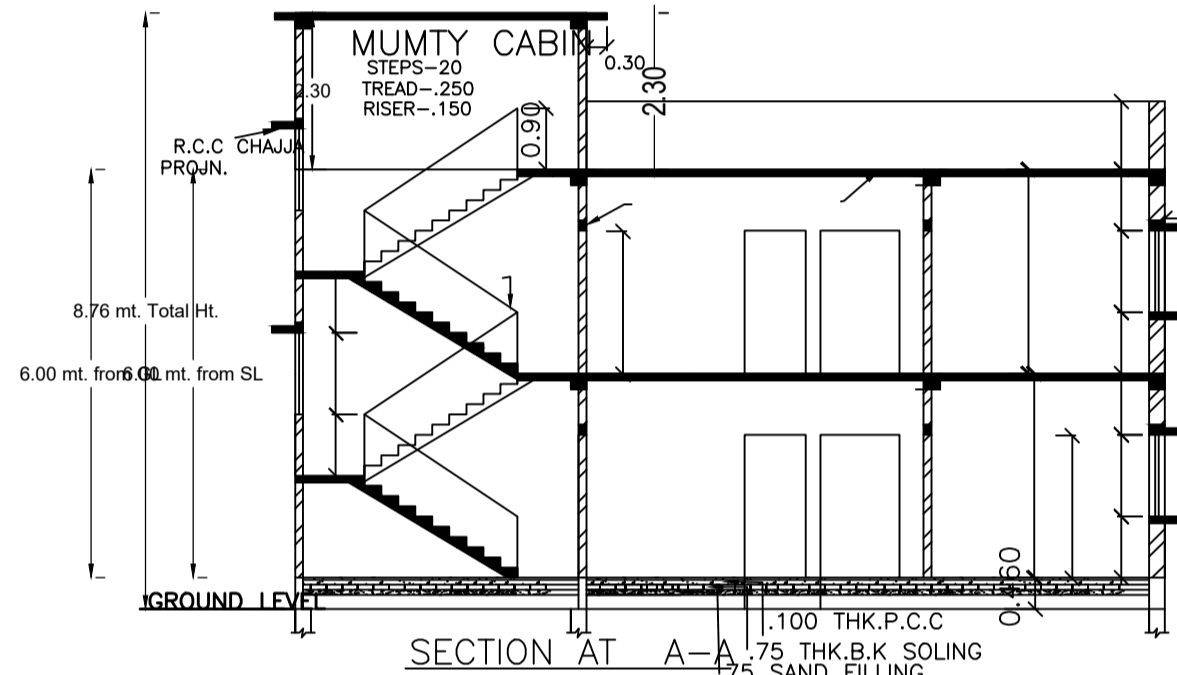
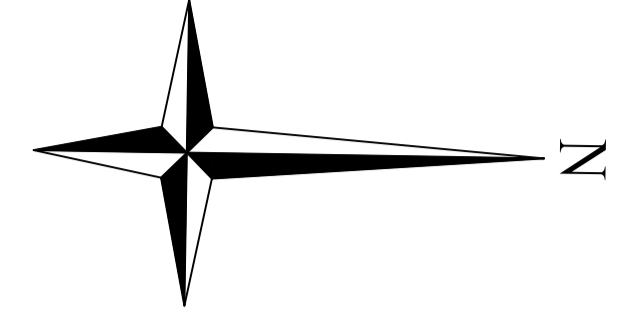

SECTION AT A-A

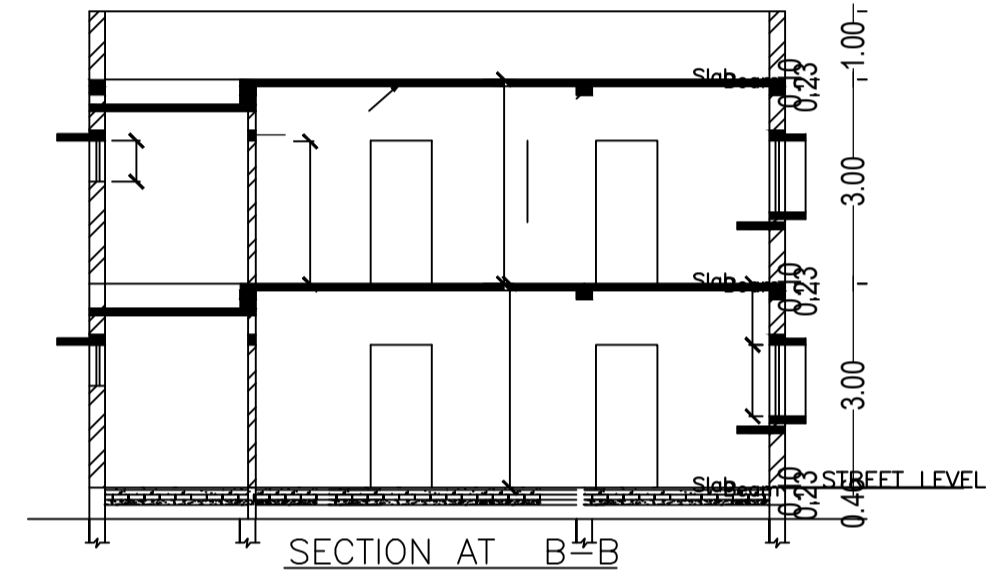

SECTION AT B-B

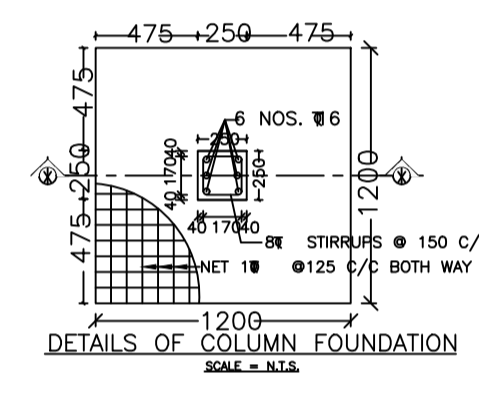

SCALE = 1/10

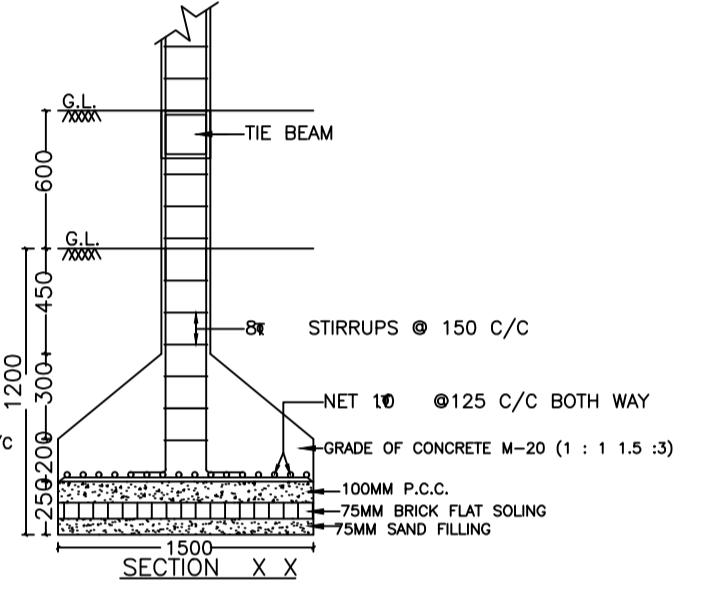

SECTION X-X

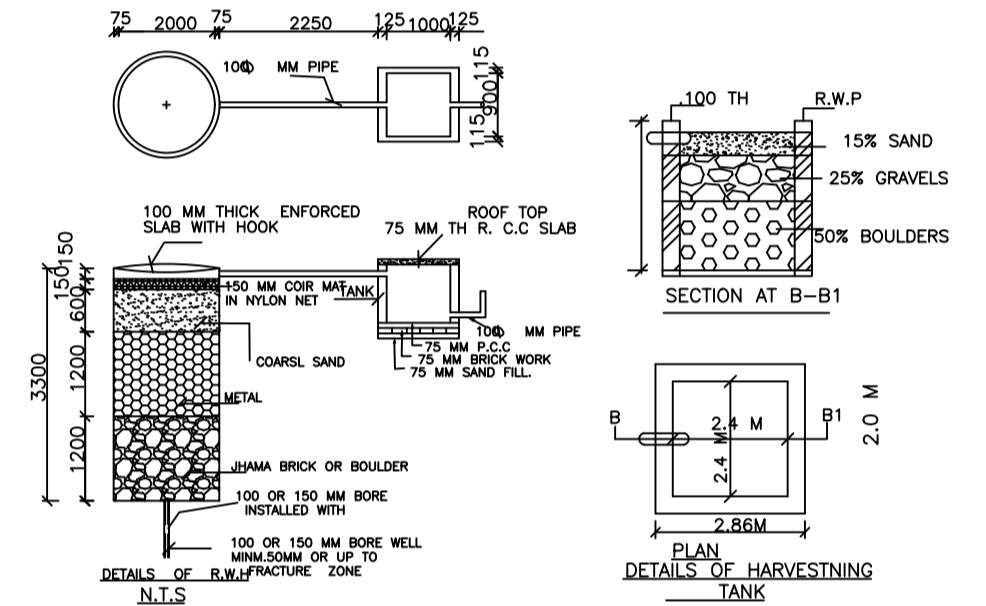

SCALE = 1/10

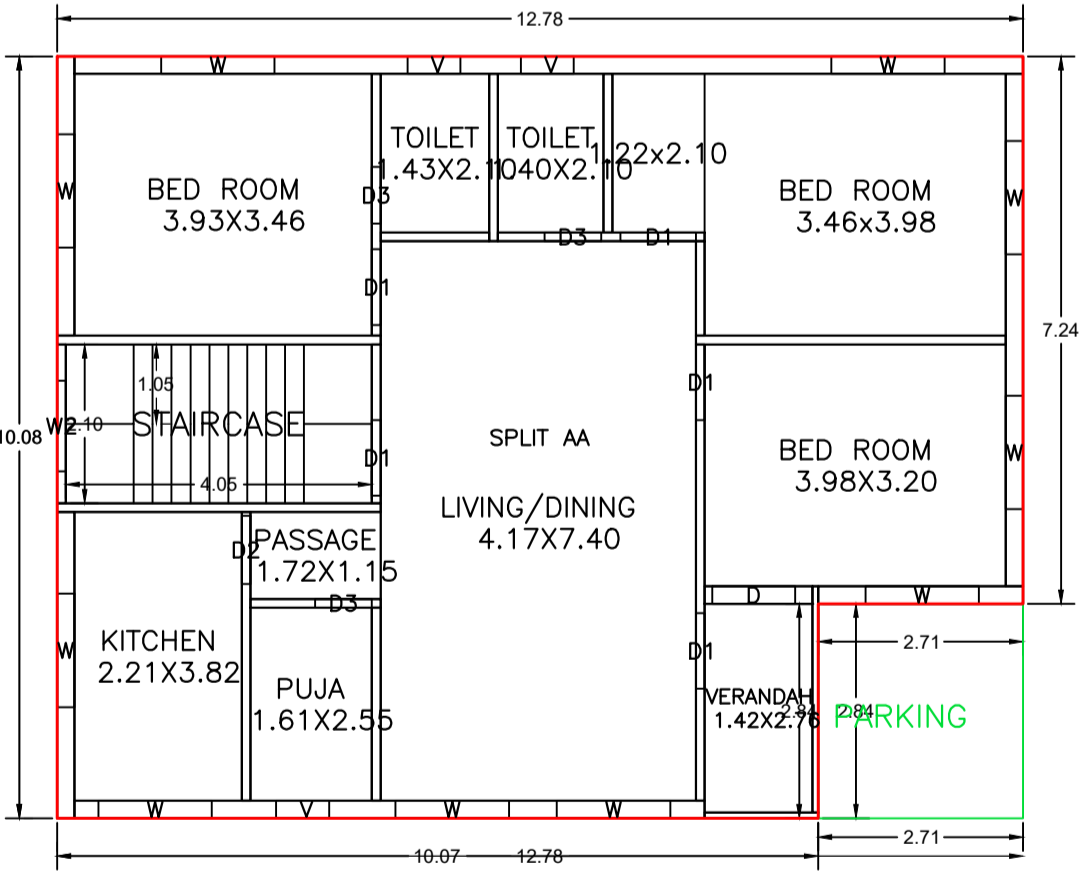

GROUND FLOOR PLAN (Proposed) (SCALE 1:100)

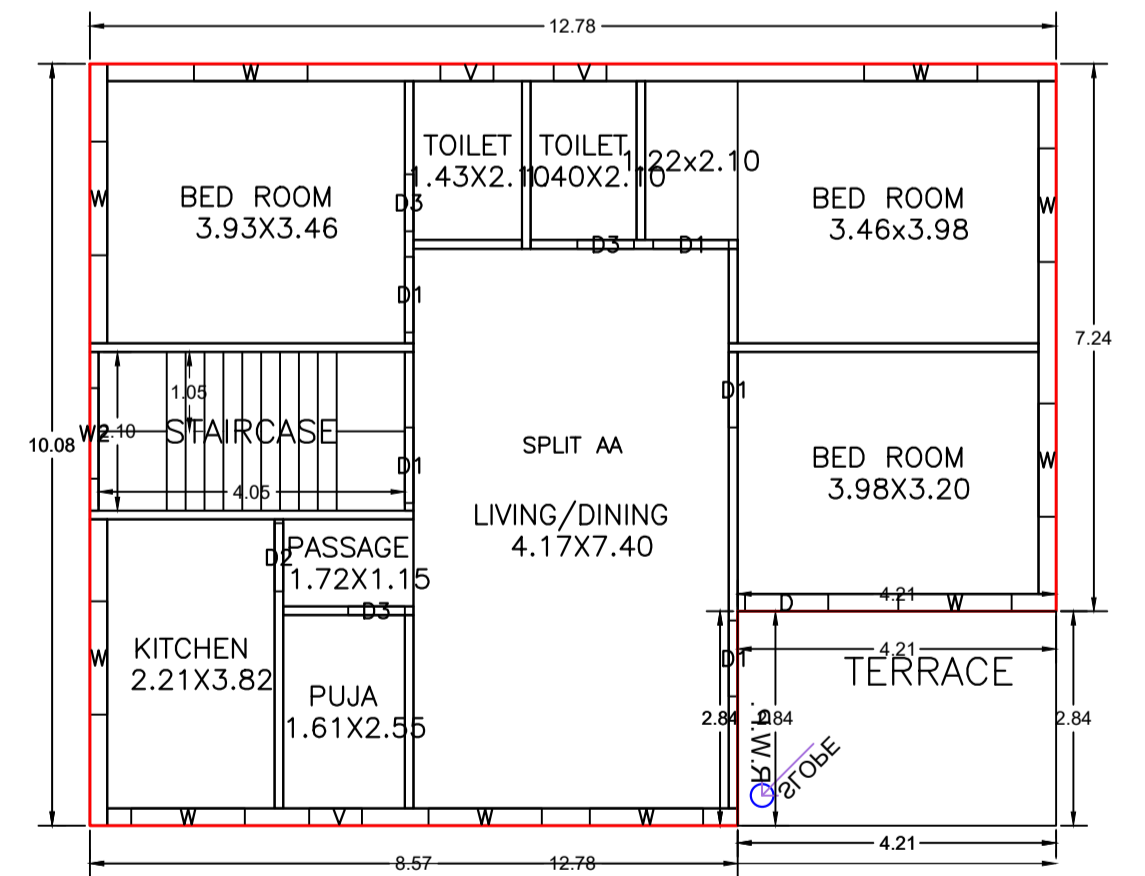

FIRST FLOOR PLAN (Proposed) (SCALE 1:100)

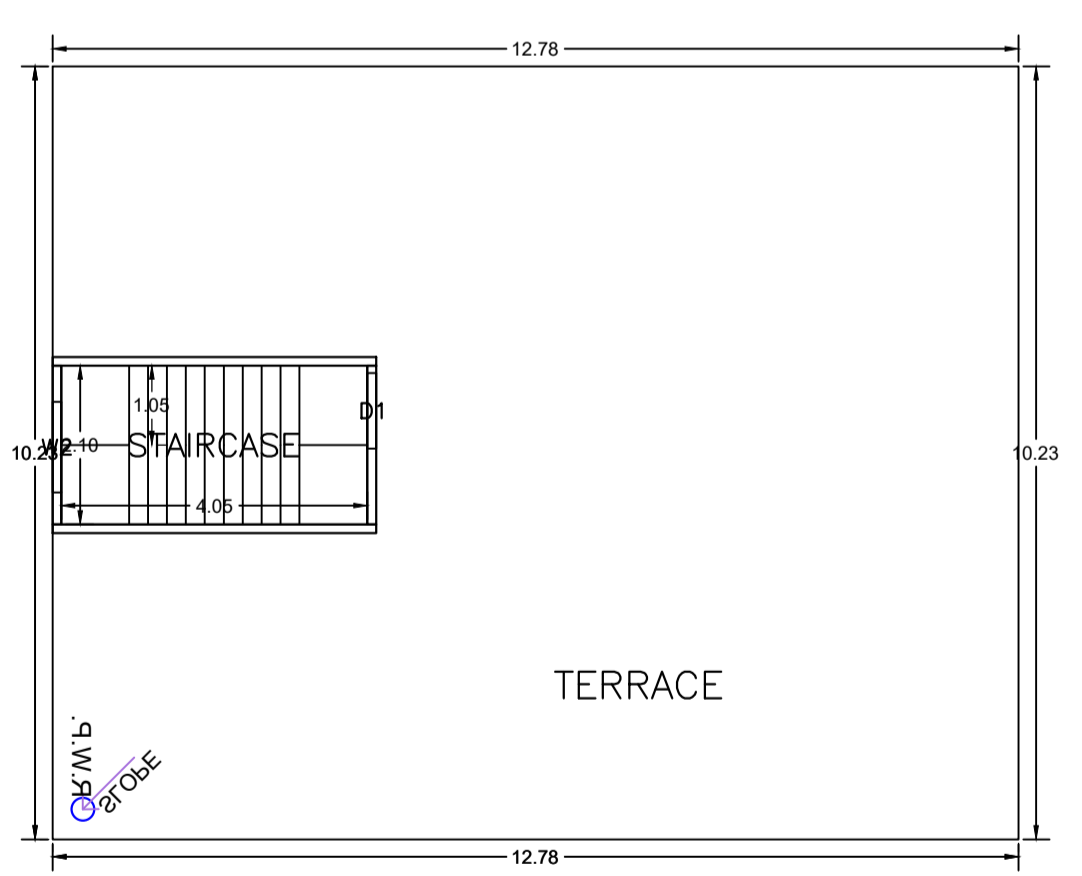

TERRACE FLOOR PLAN (SCALE 1:100)

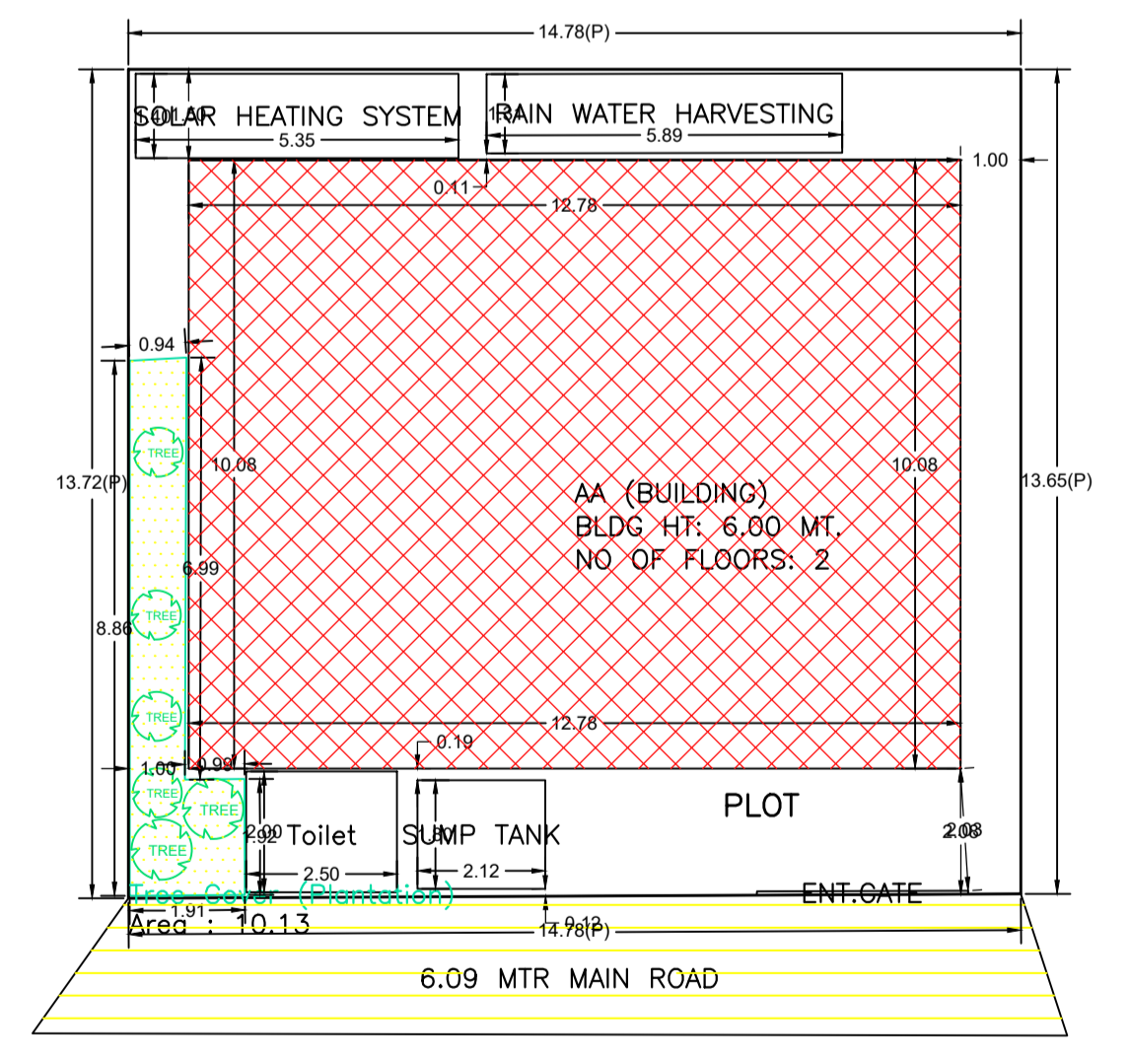

SITE PLAN

Building :AA (BUILDING)

Floor Name	Total Built Up Area (Sq.mt.)	Deductions (Area in Sq.mt.)	Proposed FAR Area (Sq.mt.)	Total FAR Area (Sq.mt.)	Total Consumed Additional FAR Area (Sq.mt.)	Trmt (No.)
Ground Floor	128.76	7.69	121.07	121.07	121.07	01
First Floor	116.82	0.00	116.82	116.82	116.82	00
Terrace Floor	0.00	0.00	0.00	0.00	0.00	00
Total :	245.58	7.69	237.89	237.89	237.89	01
Total Number of Same Buildings	1					
Total :	245.58	7.69	237.89	237.89	237.89	01

FAR & Tenement Details (Table 4c-1)

Building	No. of Same Bldg	Total Built Up Area (Sq.mt.)	Deductions (Area in Sq.mt.)	Proposed FAR Area (Sq.mt.)	Total FAR Area (Sq.mt.)	Total Consumed Additional FAR Area (Sq.mt.)	Trmt (No.)
AA (BUILDING)	1	245.58	7.69	237.89	237.89	237.89	01
Grand Total :	1	245.58	7.69	237.89	237.89	237.89	01

SCHEDULE OF DOOR:

BUILDING NAME	NAME	LENGTH	HEIGHT	NOS
AA (BUILDING)	D3	0.75	2.10	06
AA (BUILDING)	D2	0.90	2.10	02
AA (BUILDING)	D1	1.00	2.10	10
AA (BUILDING)	D	1.10	2.10	02

SCHEDULE OF WINDOW/VENTILATION:

BUILDING NAME	NAME	LENGTH	HEIGHT	NOS
AA (BUILDING)	V	0.70	1.20	06
AA (BUILDING)	W2	1.20	1.20	03
AA (BUILDING)	W	1.50	1.20	20

UnitBUA Table for Building :AA (BUILDING)

FLOOR	Name	UnitBUA Type	UnitBUA Area	Carpet Area	No. of Rooms	No. of Tenement
GROUND FLOOR	SPLIT AA	FLAT	199.39	192.19	10	1
FIRST FLOOR	SPLIT AA	FLAT	0.00	0.00	9	0
Total:	-	-	199.39	192.19	19	1

Buildingwise Floor FAR Details

Floor Name	Building Name AA (BUILDING)		Total	
	Proposed Built Up Area (Sq.mt.)	Proposed FAR Area (Sq.mt.)	Total Proposed Built Up Area (Sq.mt.)	Total FAR Area (Sq.mt.)
Ground Floor	128.76	121.07	128.76	121.07
First Floor	116.82	116.82	116.82	116.82
Terrace Floor	0.00	0.00	0.00	0.00
Total :	245.58	237.89	245.58	237.89

COLOR INDEX

PLOT BOUNDARY	Black
ABUTTING ROAD	Red
PROPOSED CONSTRUCTION	Green
COMMON PLOT	Blue
ROAD WIDENING AREA	Yellow
EXISTING (To be retained)	Light Blue
EXISTING (To be demolished)	Light Green

LTP NAME AND SIGNATURE	STRUCTURAL ENG'S NAME AND SIGNATURE	BUILDER NAME AND SIGNATURE	DIGITAL SIGNATURE
SUBHASH NARHARRAO NETRAGAONKAR CMC/ARC/0014/2018			

Building USE/SUBUSE Details

Building Name	Building Use	Building SubUse	Building Structure
AA (BUILDING)	Residential	Bungalow/ Dwelling / Non Apartment	Non-Highrise