

Project Title : AJAY KUMAR

AREA STATEMENT CHAS MUNICIPAL CORPORATION	VERSION NO. 1.0.37		
PROJECT DETAIL :	VERSION DATE: 16/10/2020		
Inward No. :	Plot Use - Residential		
Region : JAWAHAR URBAN LOCAL BODIES	Plot SubUse - Bungalow/ Dwelling / Non Apartment		
District : BOKARO	Land Use Zone : NA		
Application Type : General Proposal	Abutting Road Width :-		
Project Type : Building Permission	Plot No. :-		
Nature of Development : New	Revenue Survey No/Survey No :-		
Location : Old Area	Thana No. :-		
Sub Location : NA	Holding No. :-		
Village/Mauza Name :-	Khata No. :-		
Ward No. :-	North :-		
Road/Street :-	South :-		
	East :-		
	West :-		
AREA DETAILS :			
AREA OF PLOT (Minimum)	(A)	SQ.MT.	86.58
Net Plot Area (Gross Plot Area)			86.58
-Deduction from Gross Plot Area			
Deductions for Balance Plot Area (from Gross Plot Area)			
CSP Area			12.54
Total			12.54
Balance Plot Area (Net Plot Area - Recreational/Amenity space)	(A-Deductions)		74.04
Plot Area for Coverage (Net Plot Area)	(A-Deductions)		86.58
Plot Area for FSI (Net Plot Area + Road/Highway Area)	(A-Deductions)		86.58
Accessory/Use Area			0.37
COVERAGE CHECK			
Proposed Coverage Area ( 60.01 % )			51.96
Total Coverage Area ( 60.01 % )			51.96
FAR CHECK			
Proposed Area of FAR			103.92
Total Area of FAR			103.92
BUILT UP AREA CHECK			
Total Proposed Built Up Area			103.92
ARCH / ENGG / SUPERVISOR (Regd)		OWNER	
DEVELOPMENT AUTHORITY		LOCAL BODY	

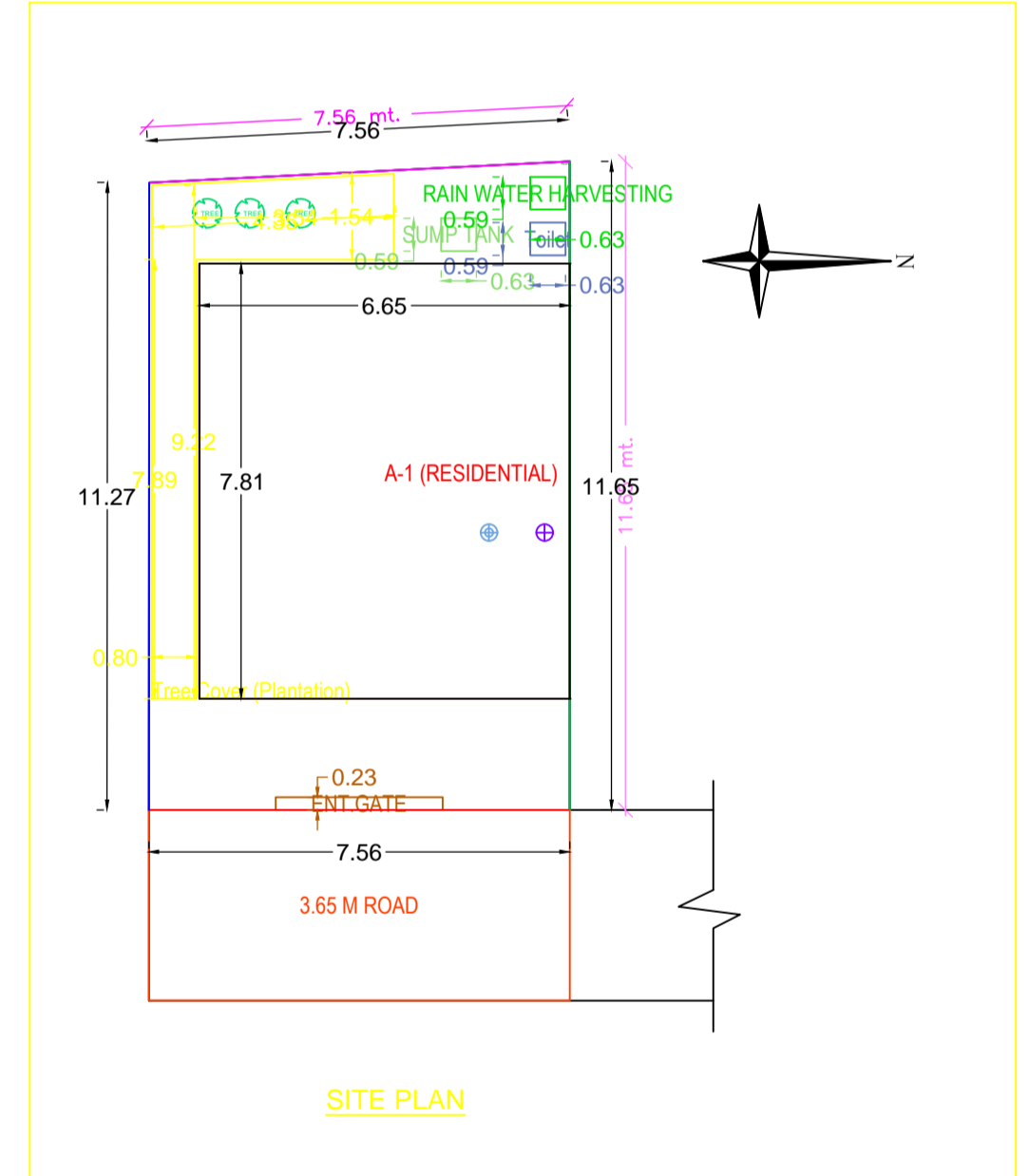
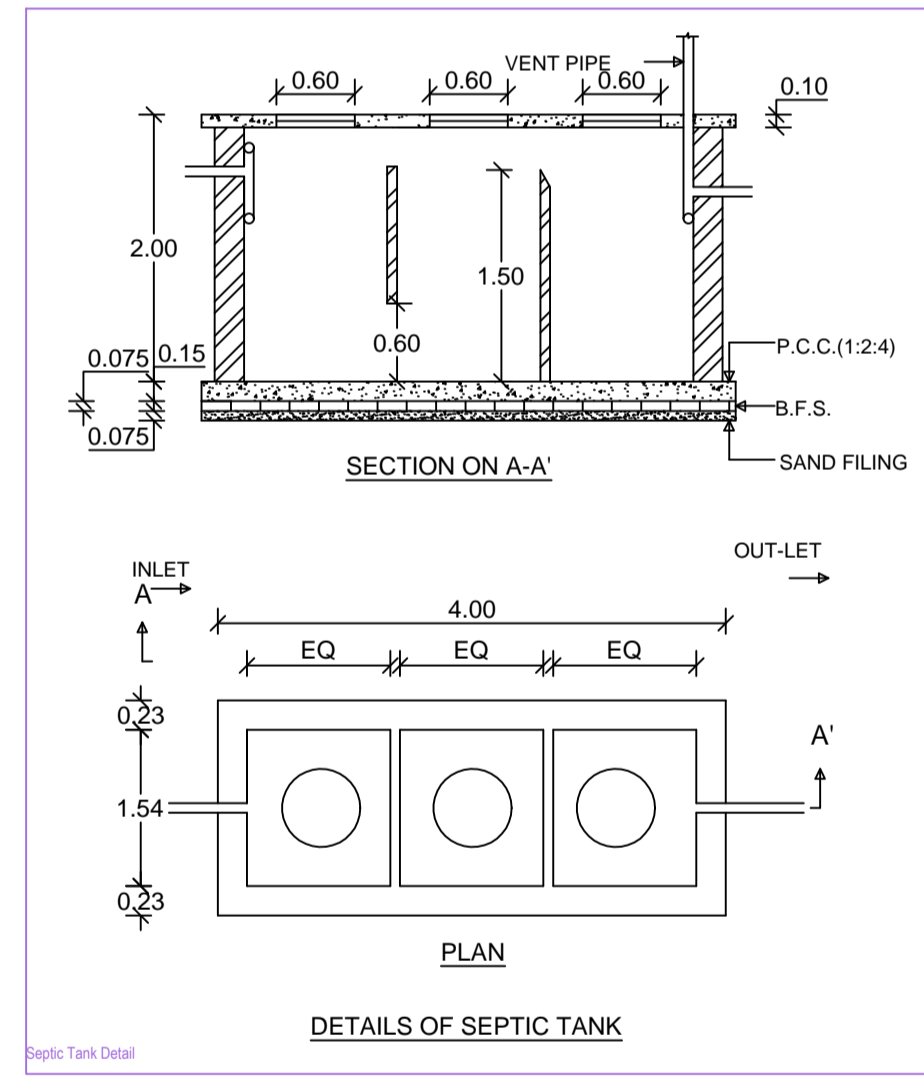
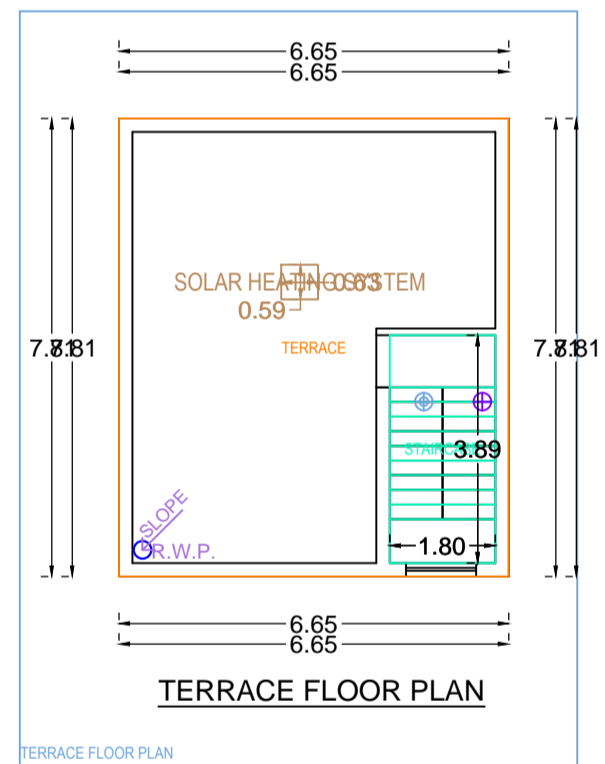
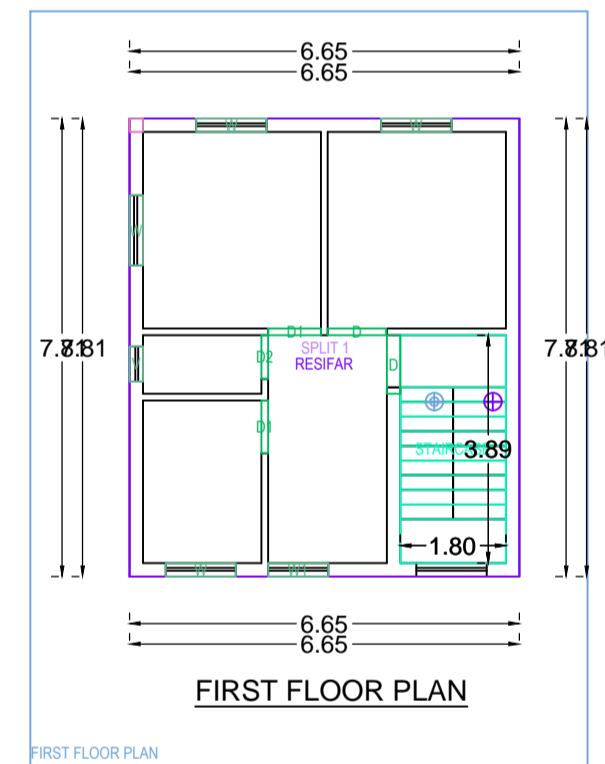
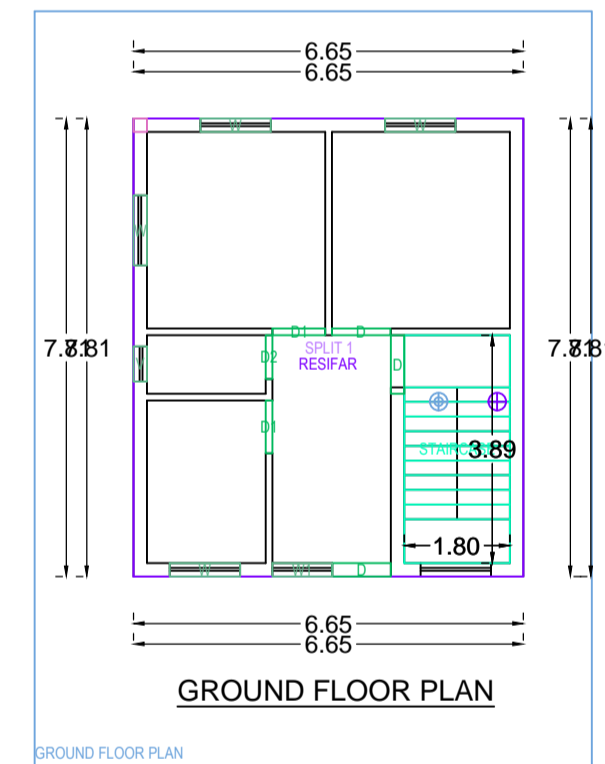
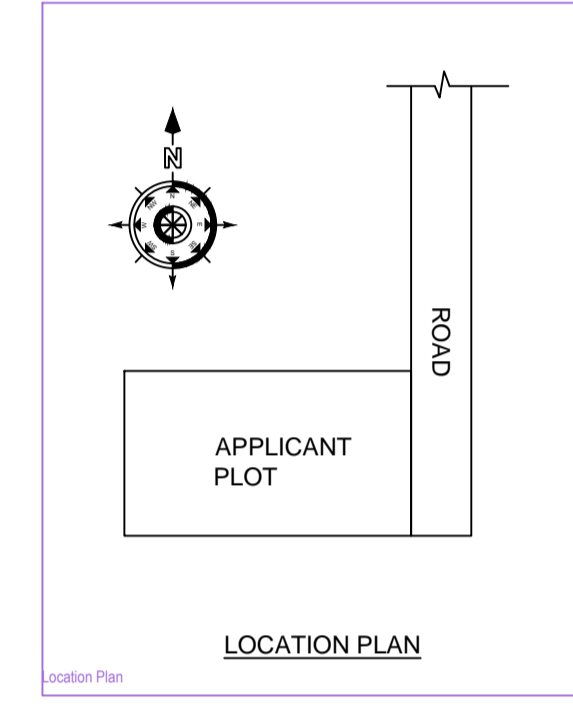
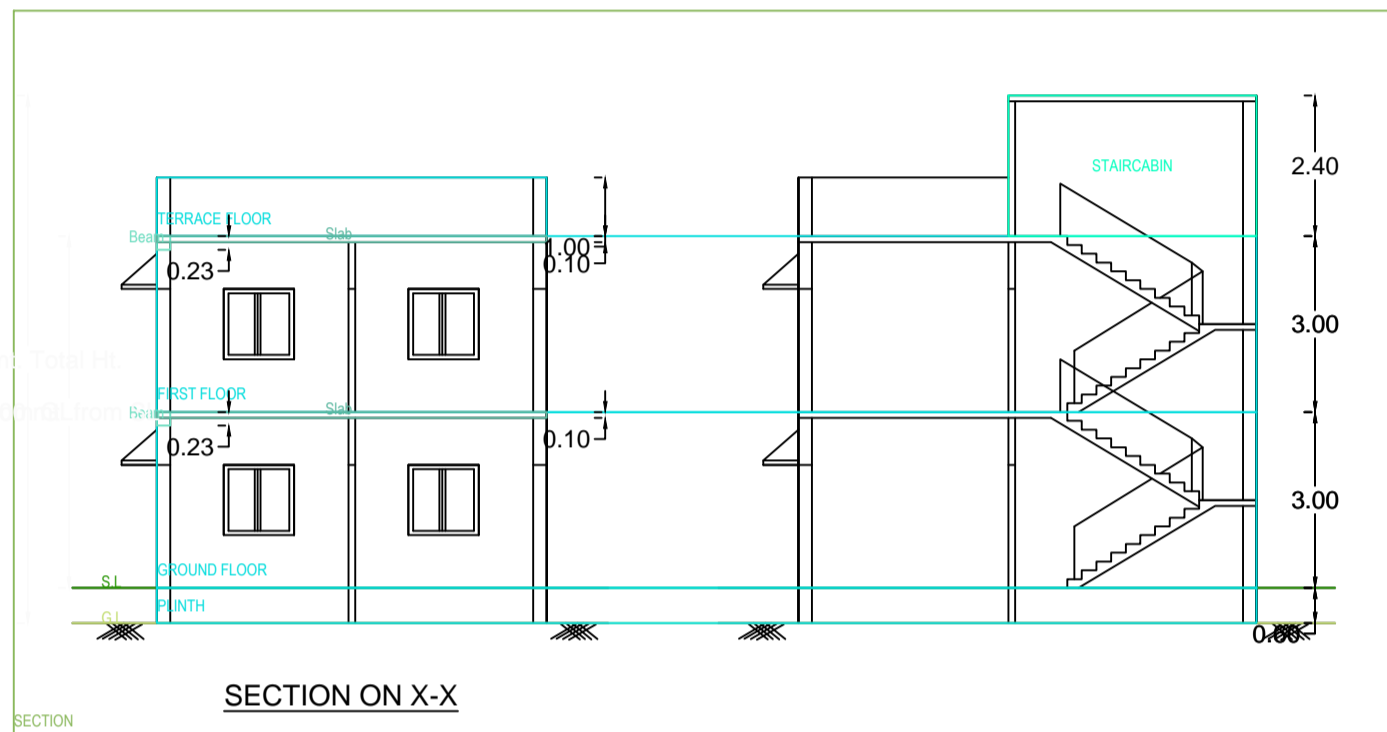
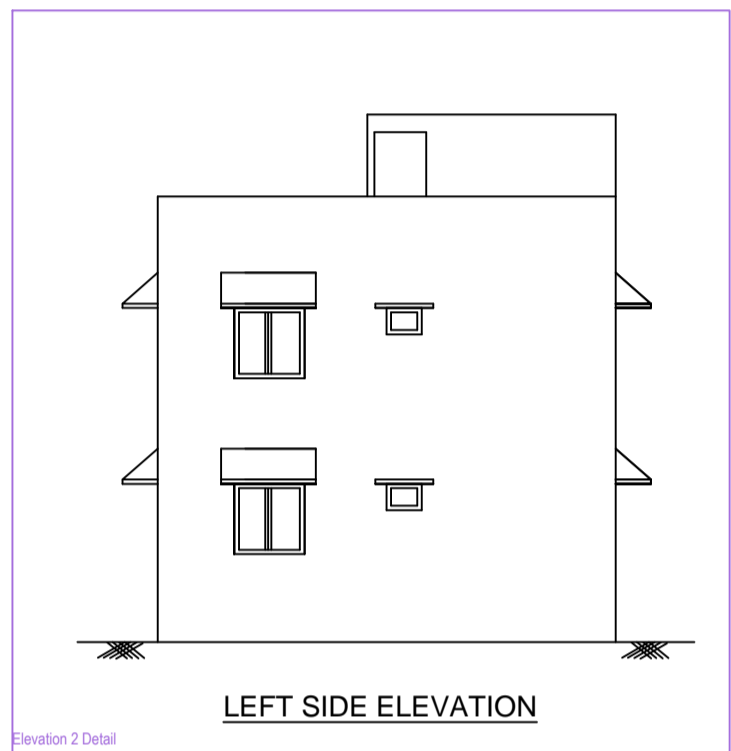
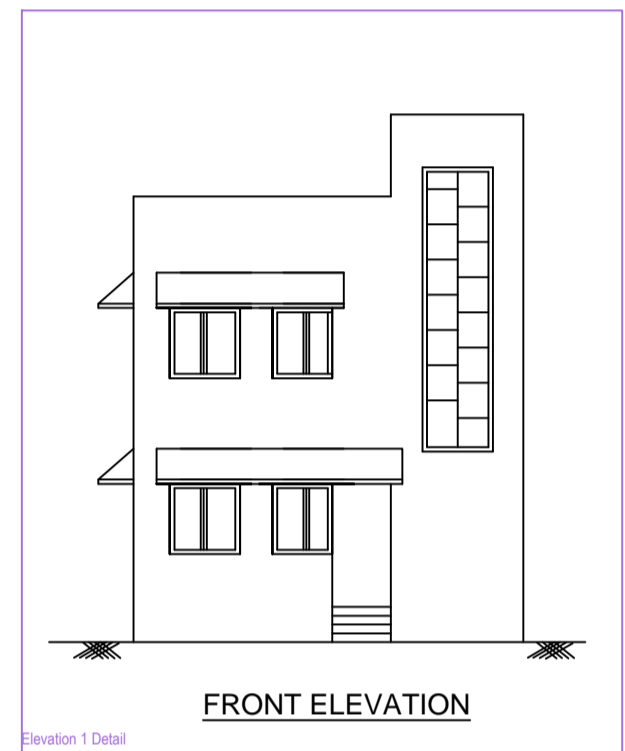
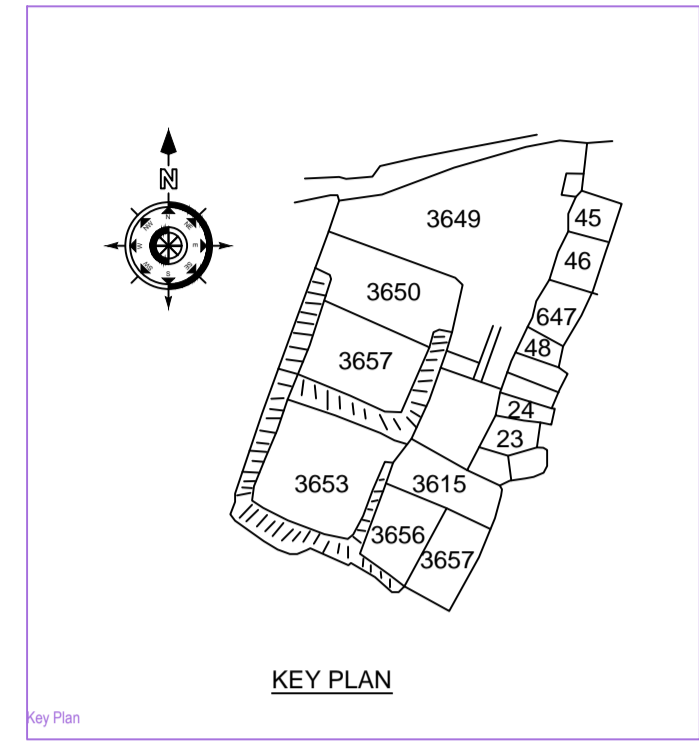
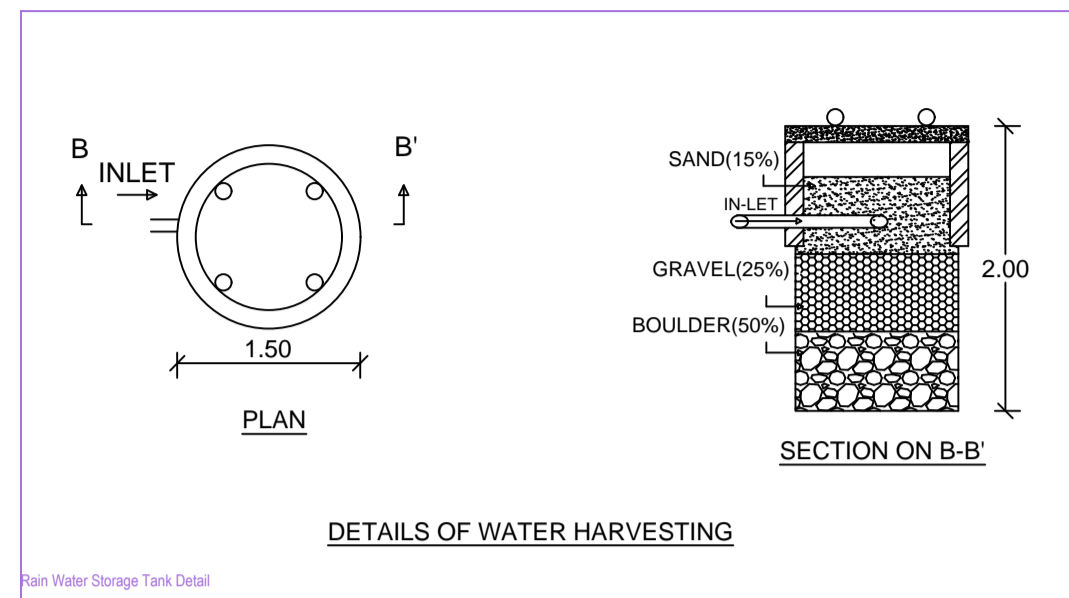
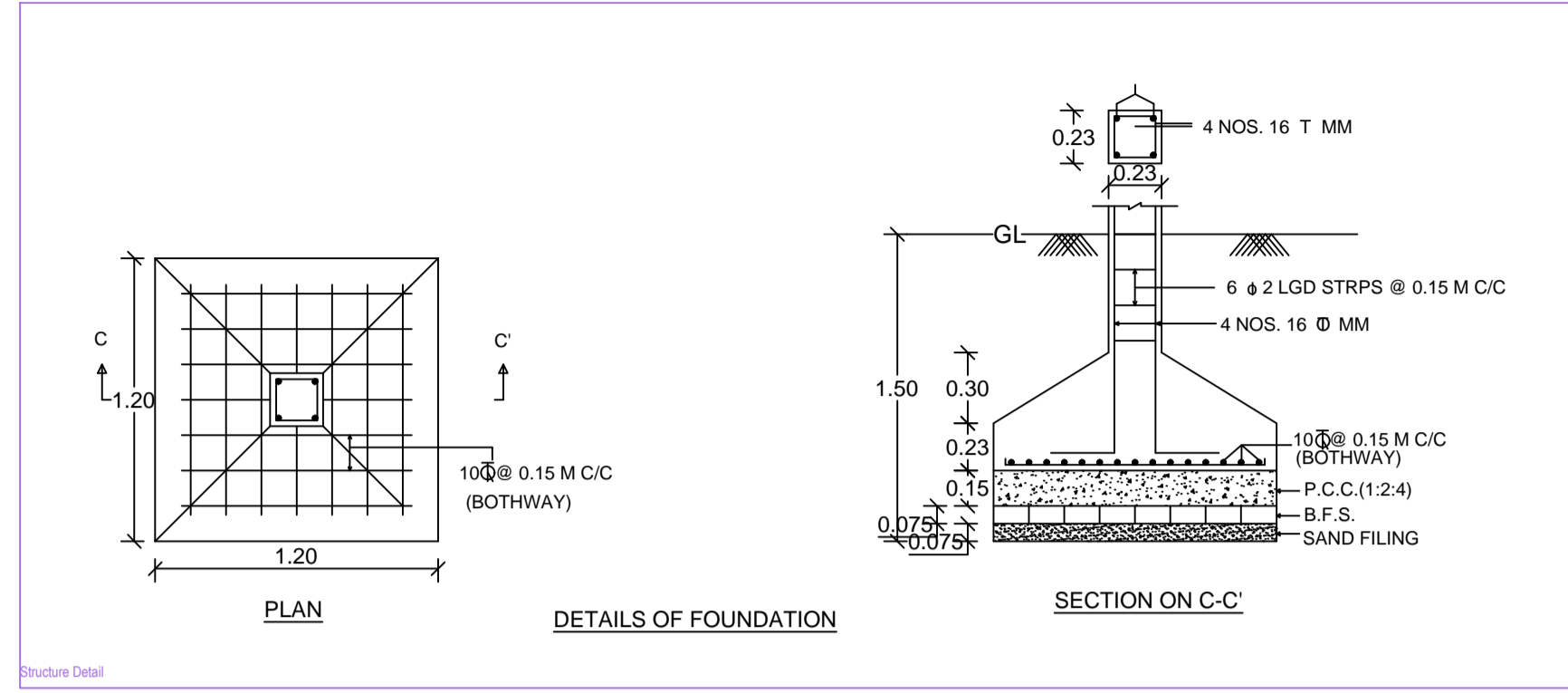

**COLOR INDEX**

PLOT BOUNDARY	Green
ABUTTING ROAD	Red
PROPOSED WORK (COVERAGE AREA)	Blue
EXISTING (To be retained)	Yellow
EXISTING (To be demolished)	Black

**MARGIN DETAIL:**

Building / Wing Name	Road Name	Front Margin	Rear Margin	Side1 Margin	Side2 Margin
A1 (RESIDENTIAL)	3.65 M ROAD	2.00	1.50	0.90	0.00

**FAR & Tenement Details (Table 4c-1)**

Building	No. of Same Bldg	Total Built Up Area (Sq.mt.)	Proposed FAR Area (Sq.mt.) Res.	Total FAR Area (Sq.mt.)	Tenmt (No.)
A (RESIDENTIAL)	1	103.92	103.92	103.92	01
<b>Grand Total</b>	<b>1</b>	<b>103.92</b>	<b>103.92</b>	<b>103.92</b>	<b>01</b>

**Building 'A' (RESIDENTIAL)**

Floor Name	Total Built Up Area (Sq.mt.)	Proposed FAR Area (Sq.mt.)		Total FAR Area (Sq.mt.)	Tenmt (No.)
		Res.			
Ground Floor	51.96	51.96	51.96	51.96	01
First Floor	51.96	51.96	51.96	51.96	00
Terrace Floor	0.00	0.00	0.00	0.00	00
<b>Total</b>	<b>103.92</b>	<b>103.92</b>	<b>103.92</b>	<b>103.92</b>	<b>01</b>
Total Number of Same Buildings	1				
<b>Total</b>	<b>103.92</b>	<b>103.92</b>	<b>103.92</b>	<b>103.92</b>	<b>01</b>

**SCHEDULE OF JOINERY:**

BUILDING NAME	NAME	LENGTH	HEIGHT	NOS
A (RESIDENTIAL)	D2	0.75	2.10	02
A (RESIDENTIAL)	D1	0.90	2.10	04
A (RESIDENTIAL)	D	1.00	2.10	05
<b>Total</b>	-	-	-	<b>11</b>

**SCHEDULE OF JOINERY:**

BUILDING NAME	NAME	LENGTH	HEIGHT	NOS
A (RESIDENTIAL)	V	0.60	1.00	02
A (RESIDENTIAL)	W1	1.02	1.20	02
A (RESIDENTIAL)	W	1.20	1.20	08
<b>Total</b>	-	-	-	<b>12</b>

**UnitBUA Table for Building 'A' (RESIDENTIAL)**

FLOOR	Name	UnitBUA Type	UnitBUA Area	Carpet Area	No. of Rooms	No. of Tenement
GROUND FLOOR PLAN	SPLIT 1	FLAT	103.92	103.82	5	1
<b>Total</b>	-	-	<b>103.92</b>	<b>103.82</b>	<b>10</b>	<b>1</b>

A (RESIDENTIAL)