

FRONT ELEVATION SCALE = N.T.S.

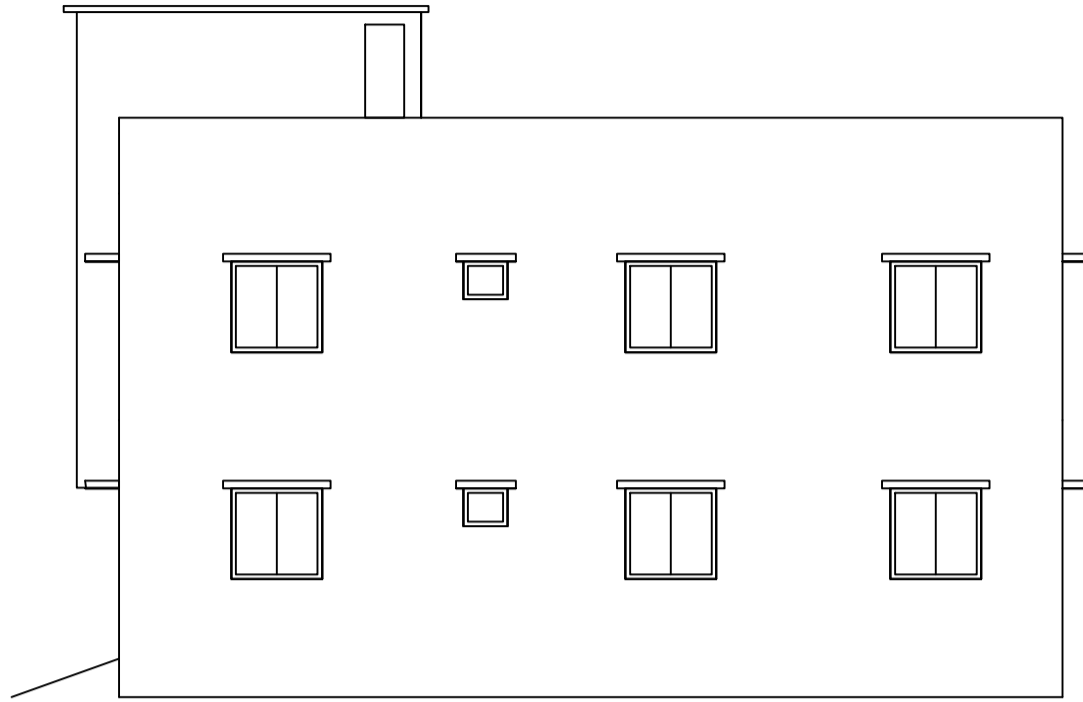

RIGHT ELEVATION

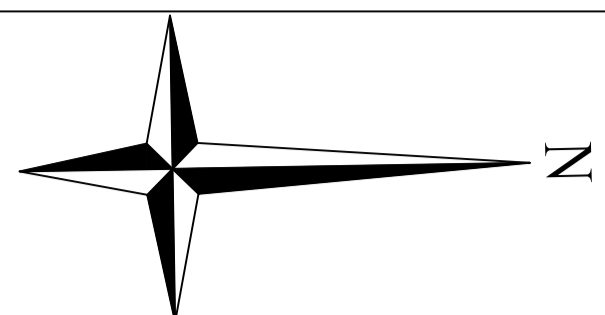
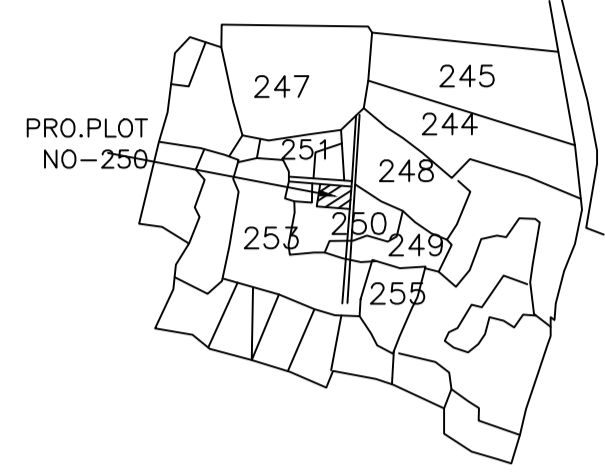
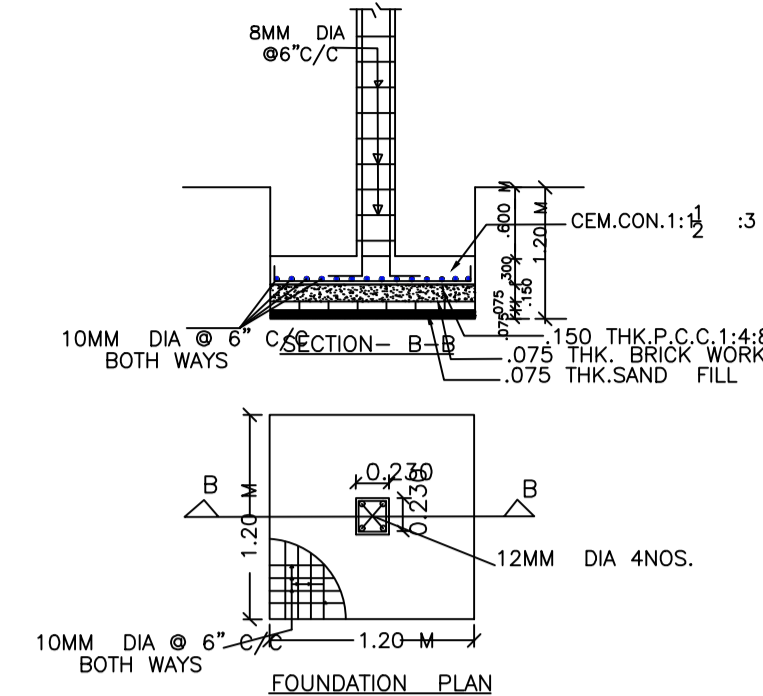
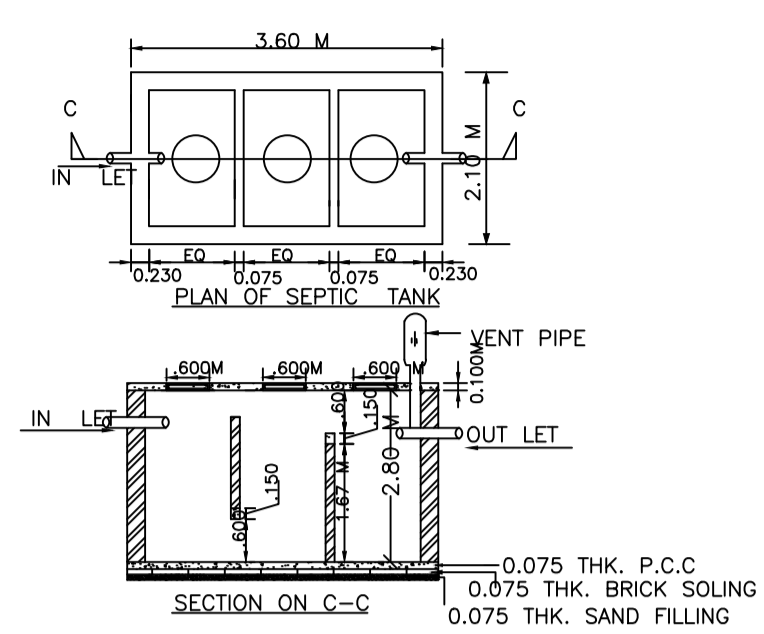

Proposal Basic Information	
Proposal File No.	CMC/BP/0035/W10/2024
Owner Name	MD AMIR HUSSAIN
Khata No	257
Plot No	250
Village Name	Chas
Use	Residential
SubUse	Bungalow/ Dwelling / Non Apartment

AREA STATEMENT CHAS MUNICIPAL CORPORATION		VERSION NO. : 1.0.70
PROJECT DETAIL		VERSION DATE: 16/10/2020
Region: JHARKHAND URBAN LOCAL BODIES	Plot Use: Residential	
District: BOKARO	Plot SubUse: Bungalow/ Dwelling / Non Apartment	
Authority: CHAS MUNICIPAL CORPORATION	PlotNearbyReligiousStructure: NA	
Inward No: CMC/BP/0035/W10/2024	Plot/SubPlot No: 250	
Application Type: General Proposal	North: Road Width - 3.04 MTR	
Project Type: Building Permission	South: CTS No. - HAZI MAFUZ	
Nature of Development: New	East: Road Width - 3.65 MTR	
Location of Development Area: Old Area	West: CTS No. - SHARIFUDDIN ANSARI	

AREA DETAILS:		SQ. MT.
AREA OF PLOT (Minimum)	(A)	200.70
Deduction for NetPlot Area		
Road Widening Area		6.84
Total		6.84
NET AREA OF PLOT(Gross Plot Area - Deduction from Gross Plot area)	(A-Deductions)	193.86
Deduction for Balance Plot Area(from Gross Plot Area)		
Road Widening Area		6.84
Common Plot		15.63
Total		22.47
BALANCE AREA OF PLOT(Net Plot Area - Recreational/Amenity space)	(A-Deductions)	178.22
PLOT AREA FOR COVERAGE(Net Plot Area)	(A-Deductions)	193.86
Plot Area for FAR (Net Plot Area + RoadWidening Area)	(A-Deductions)	193.86

COVERAGE CHECK		
Permissible Coverage area (70.00 %)		135.70
Proposed Coverage Area (61.19 %)		118.62
Total Prop. Coverage Area (61.19 %)		118.62
Balance coverage area (8.81 %)		17.08

FAR CHECK		
Perm. FAR Area (1.500)		290.79
Total Perm. FAR area		290.79
Residential FAR		225.18
Proposed FAR Area		225.18
Total Proposed FAR Area		225.18
Consumed FAR (Factor)		1.16
Balance FAR Area		65.61

BUILT UP AREA CHECK		
Total Proposed BuiltUp Area		237.69

ARCHITECT (Regd)		RAGHUNATH MAHATO
ENGINEER (Regd)		
SUPERVISOR (Regd)		
OWNER (Regd)	MD AMIR HUSSAIN	
DEVELOPMENT AUTHORITY	LOCAL BODY	

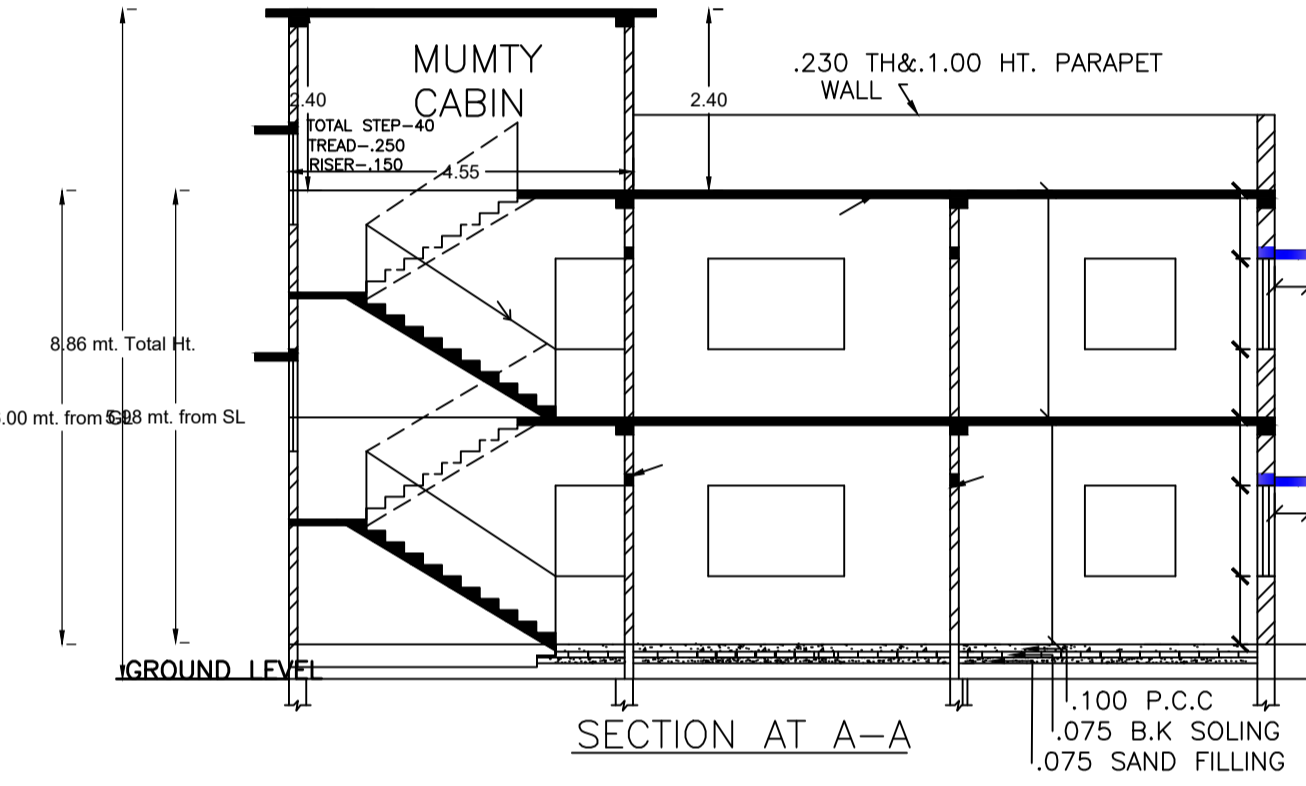

SECTION AT A-A

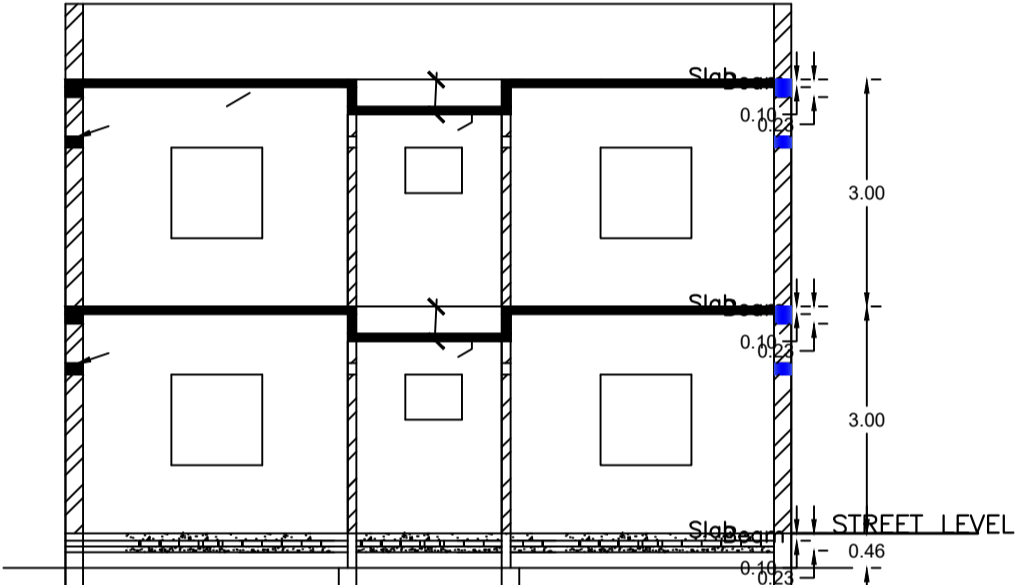

SECTION AT B-B

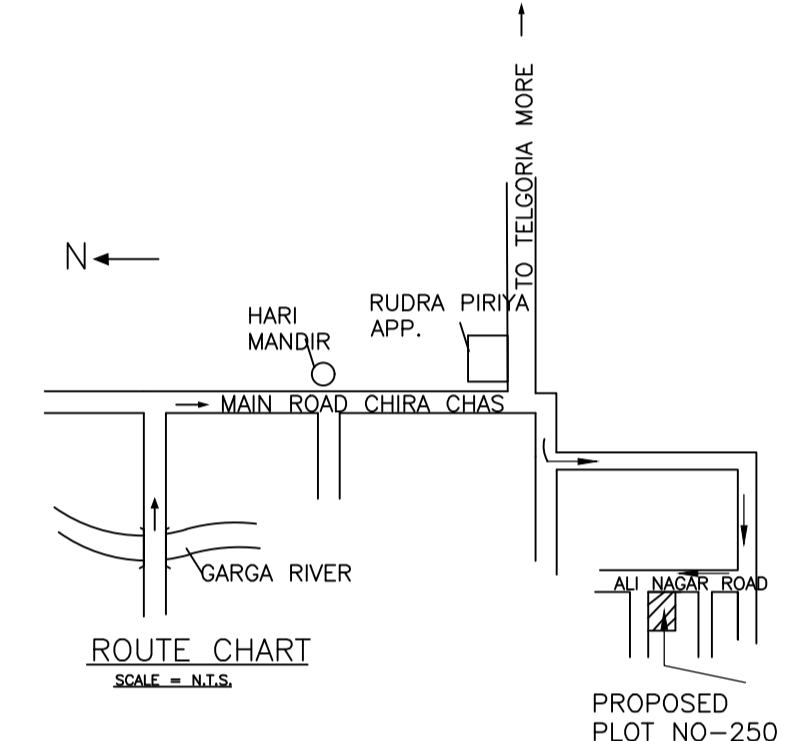
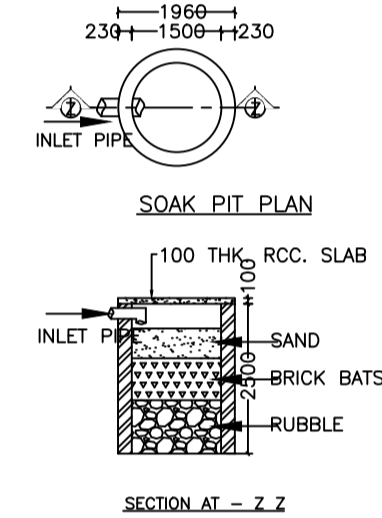
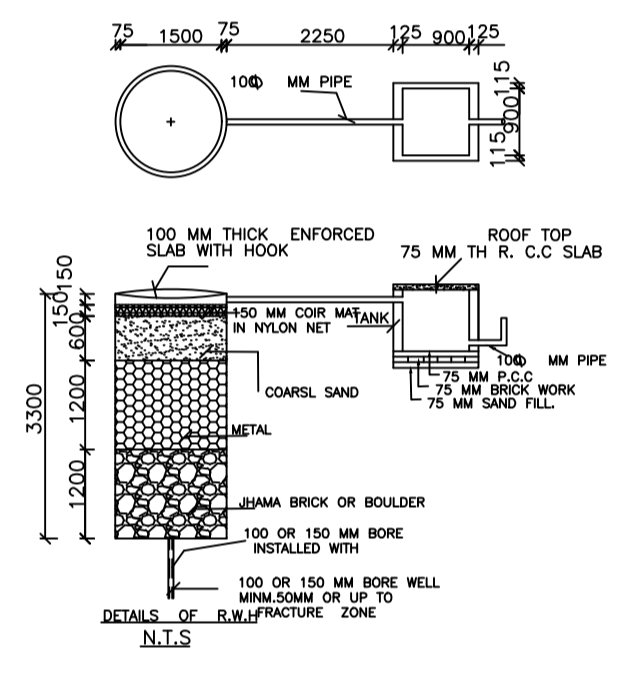

ROUTE CHART SCALE = N.T.S.

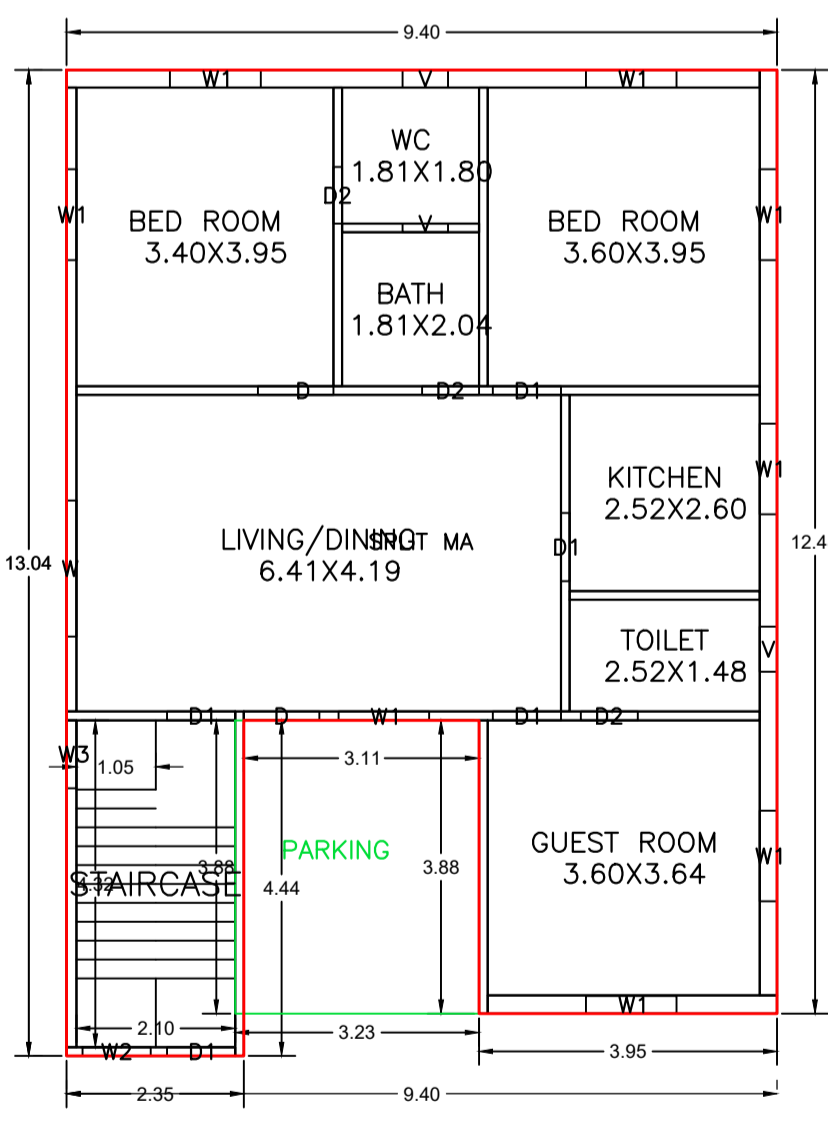

GROUND FLOOR PLAN (Proposed) (SCALE 1:100)

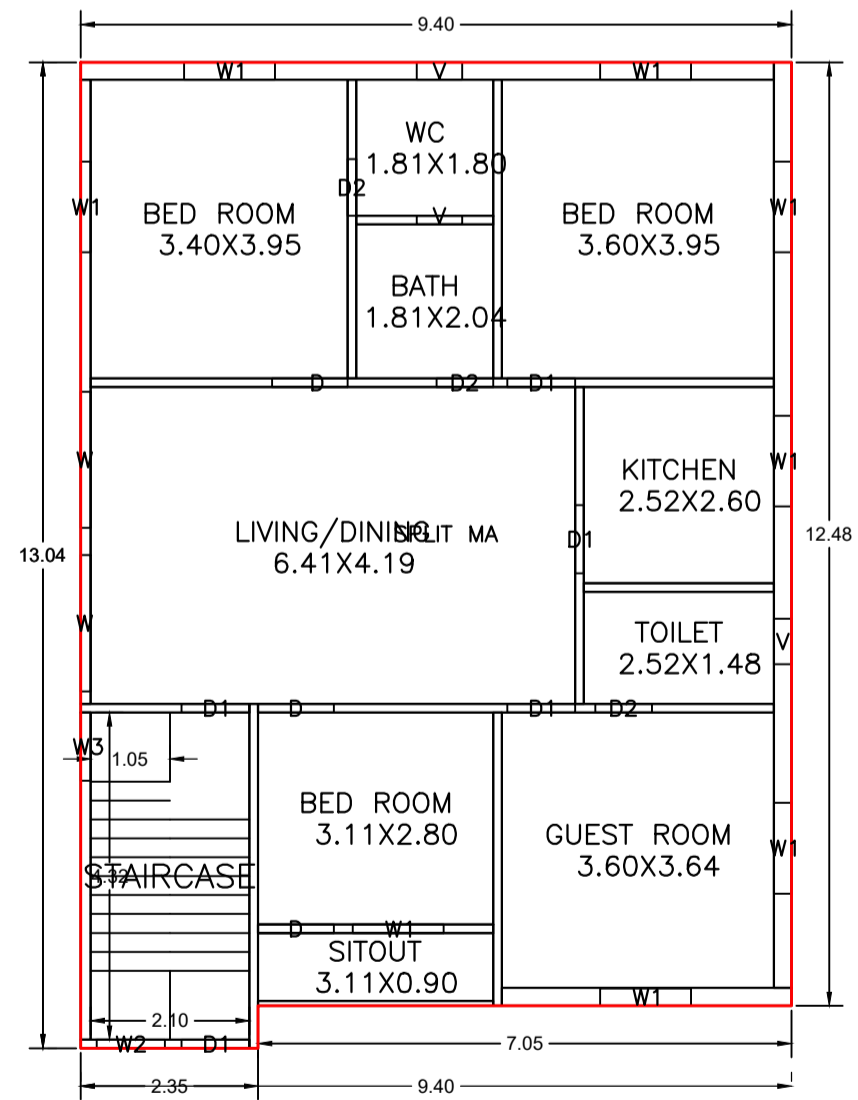

FIRST FLOOR PLAN (Proposed) (SCALE 1:100)

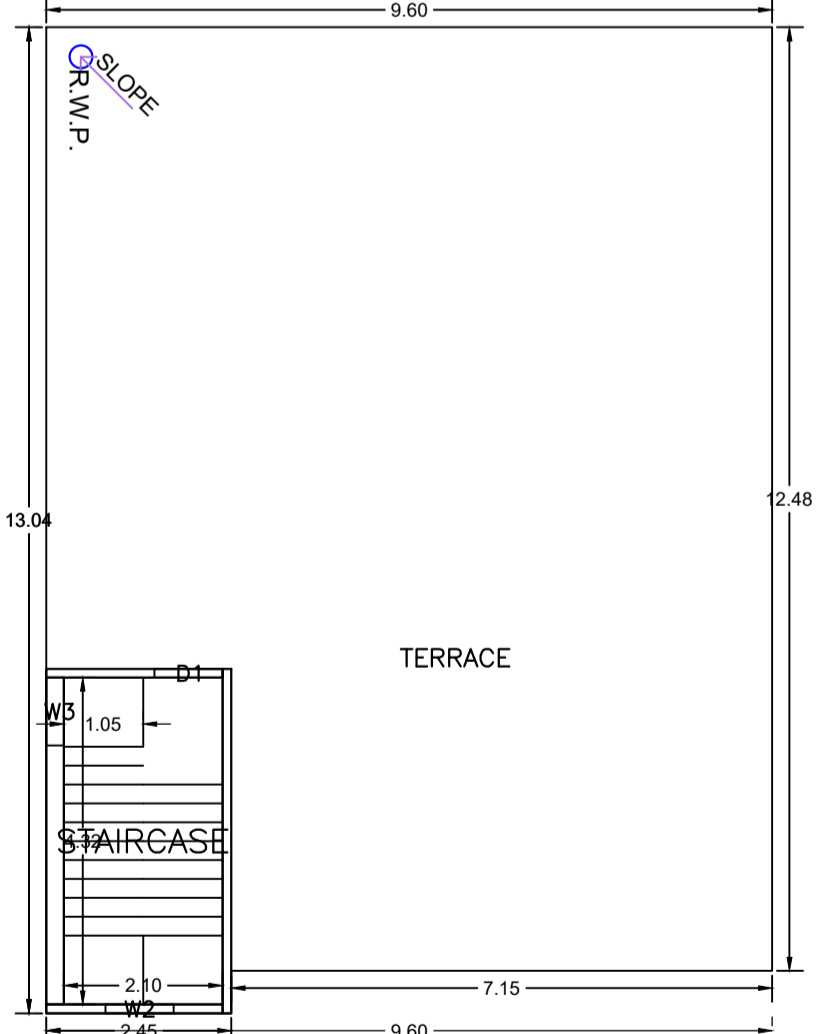

TERRACE FLOOR PLAN (SCALE 1:100)

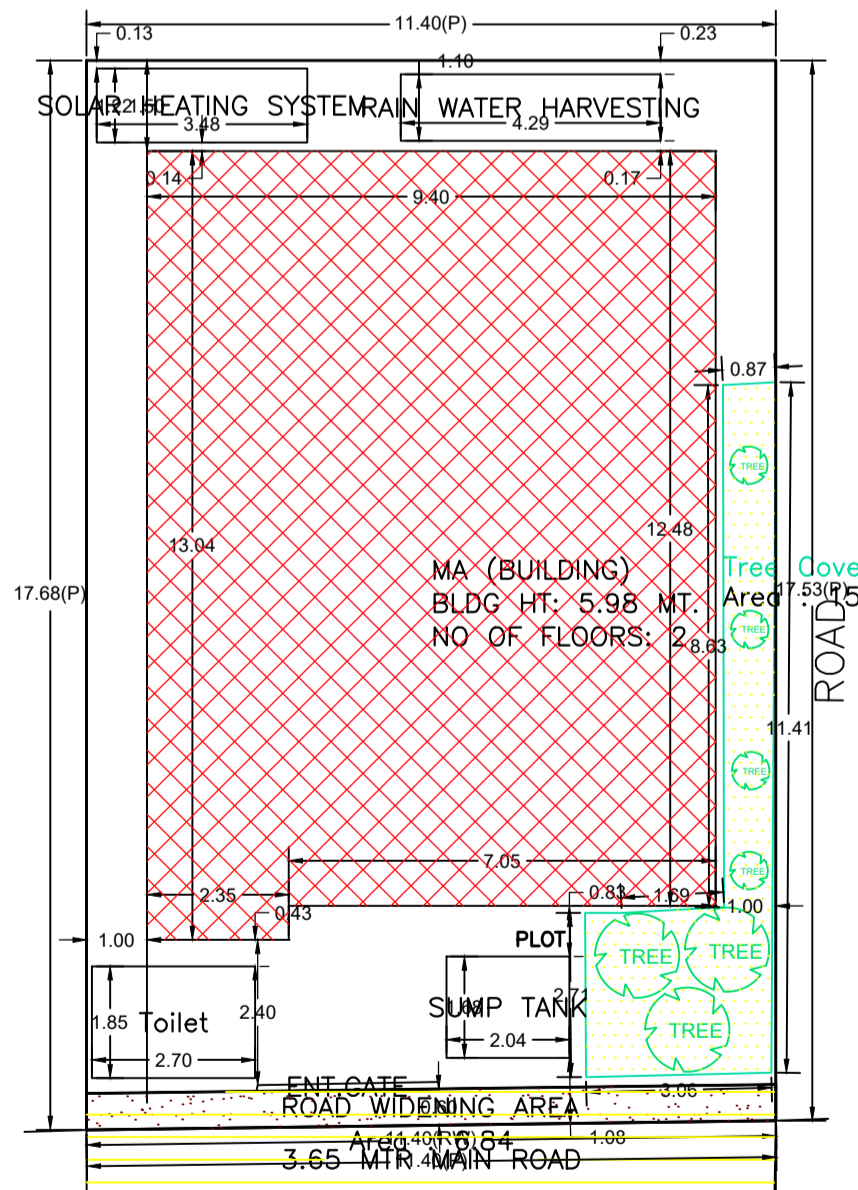

SITE PLAN

Building :MA (BUILDING)						
Floor Name	Total Built Up Area (Sq.mt.)	Deductions (Area in Sq.mt.)	Proposed FAR Area (Sq.mt.)	Total FAR Area (Sq.mt.)	Total Consumed Additional FAR Area (Sq.mt.)	Trmt (No.)
Ground Floor	119.07	12.51	106.56	106.56	106.56	01
First Floor	118.62	0.00	118.62	118.62	118.62	00
Terrace Floor	0.00	0.00	0.00	0.00	0.00	00
Total :	237.69	12.51	225.18	225.18	225.18	01
Total Number of Same Buildings	1					
Total :	237.69	12.51	225.18	225.18	225.18	01

SCHEDULE OF DOOR:				
BUILDING NAME	NAME	LENGTH	HEIGHT	NOS
MA (BUILDING)	D2	0.75	2.10	06
MA (BUILDING)	D1	0.90	2.10	08
MA (BUILDING)	D	1.00	2.10	05

SCHEDULE OF WINDOW/VENTILATION:				
BUILDING NAME	NAME	LENGTH	HEIGHT	NOS
MA (BUILDING)	V	0.60	0.60	06
MA (BUILDING)	W2	0.90	1.20	03
MA (BUILDING)	W3	0.90	1.20	03
MA (BUILDING)	W1	1.20	1.20	16
MA (BUILDING)	W	1.80	1.20	03

Building USE/SUBUSE Details			
Building Name	Building Use	Building SubUse	Building Structure
MA (BUILDING)	Residential	Bungalow/ Dwelling / Non Apartment	Non-Highrise

FAR & Tenement Details (Table 4c-1)						
FLOOR	Name	UnitBUA Type	UnitBUA Area	Carpet Area	No. of Rooms	No. of Tenement
GROUND FLOOR PLAN	SPLIT MA	FLAT	188.93	181.73	8	1
FIRST FLOOR PLAN	SPLIT MA	FLAT	0.00	0.00	10	0
Total:	-	-	188.93	181.73	18	1

Buildingwise Floor FAR Details				
Floor Name	Building Name MA (BUILDING)		Total	
	Proposed Built Up Area (Sq.mt.)	Proposed FAR Area (Sq.mt.)	Total Proposed Built Up Area (Sq.mt.)	Total FAR Area (Sq.mt.)
Ground Floor	119.07	106.56	119.07	106.56
First Floor	118.62	118.62	118.62	118.62
Terrace Floor	0.00	0.00	0.00	0.00
Total :	237.69	225.18	237.69	225.18

COLOR INDEX	
PLOT BOUNDARY	Black
ABUTTING ROAD	Red
PROPOSED CONSTRUCTION	Green
COMMON PLOT	Blue
ROAD WIDENING AREA	Yellow
EXISTING (To be retained)	Orange
EXISTING (To be demolished)	Purple

LTP NAME AND SIGNATURE	STRUCTURAL ENG'S NAME AND SIGNATURE	BUILDER NAME AND SIGNATURE	DIGITAL SIGNATURE
RAGHUNATH MAHATO CMC/DFTM/0033/2017			