

Proposal Basic Information

Proposal File No.	CMC/BP/0102/W04/2024
Owner Name	ANKIT KUMAR
Khata No	01
Plot No	1494
Village Name	Chas
Use	Residential
SubUse	Bungalow/ Dwelling / Non Apartment

AREA STATEMENT CHAS MUNICIPAL CORPORATION
VERSION NO: 1.0.73
VERSION DATE: 16/10/2020

Region: JHARKHAND URBAN LOCAL BODIES	Plot Use: Residential
District: BOKARO	Plot SubUse: Bungalow/ Dwelling / Non Apartment
Authority: CHAS MUNICIPAL CORPORATION	PlotNearbyReligiousStructure: NA
Inward No: CMC/BP/0102/W04/2024	PlotSubPlot No: 1494
Application Type: General Proposal	North: CTS No. - GEETA DEVI
Project Type: Building Permission	South: CTS No. - MRITUNJAY GOPE
Nature of Development: New	East: Road Width - 6.10 MTR. WIDE ROAD
Location of Development Area: Old Area	West: CTS No. - PRAWEEEN KUMAR & PART OF PLOT

AREA OF PLOT (Minimum)	(A)	SQ. MT.	123.31
NET AREA OF PLOT(Gross Plot Area - Deduction from Gross Plot area)	(A-Deductions)		123.31

Deduction for Balance Plot Area(from Gross Plot Area)			
Common Plot			22.95
Total			22.95

BALANCE AREA OF PLOT(Net Plot Area - Recreational/Amenity space)	(A-Deductions)		100.36
PLOT AREA FOR COVERAGE(Net Plot Area)	(A-Deductions)		123.31
Plot Area for FAR (Net Plot Area + Road Widening Area)	(A-Deductions)		123.31

COVERED AREA			
Permissible Coverage area (70.00 %)			86.32
Proposed Coverage Area (61.46 %)			75.78
Total Prop. Coverage Area (61.46 %)			75.78
Balance coverage area (8.55 %)			10.54

FAR CHECK			
Perm. FAR Area (2.500)			308.27
Total Perm. FAR area			308.27
Residential FAR			151.57
Proposed FAR Area			151.57
Total Proposed FAR Area			151.57
Consumed FAR (Factor)			1.23
Balance FAR Area			156.70

BUILT UP AREA CHECK			
Total Proposed BuiltUp Area			151.56

ARCHITECT (Regd)		PANKAJ GUPTA
ENGINEER (Regd)		
SUPERVISOR (Regd)		ANKIT KUMAR
OWNER (Regd)		

DEVELOPMENT AUTHORITY	LOCAL BODY
-----------------------	------------

COLOR INDEX	
PLOT BOUNDARY	Black
ABUTTING ROAD	Green
PROPOSED CONSTRUCTION	Red
COMMON PLOT	Yellow
ROAD WIDENING AREA	Orange
EXISTING (To be retained)	Blue
EXISTING (To be demolished)	Light Blue

Buildingwise Floor FAR Details				
Floor Name	Building Name		Total	
	Proposed Built Up Area (Sq.mt.)	Proposed FAR Area (Sq.mt.)	Total Proposed Built Up Area (Sq.mt.)	Total FAR Area (Sq.mt.)
Ground Floor	75.78	75.78	75.78	75.78
First Floor	75.78	75.78	75.78	75.78
Terrace Floor	0.00	0.00	0.00	0.00
Total :	151.56	151.56	151.56	151.56

Building USE/SUBUSE Details									
Building Name	Building Use	Building SubUse	Building Structure	Floor Name	Floor Use	Floor SubUse	FAR Name	FAR Use	FAR SubUse
ANKIT KUMAR (BUILDING)	Residential	Bungalow/ Dwelling / Non Apartment	Non-Highrise	GROUND FLOOR PLAN	Residential	Bungalow/ Dwelling / Non Apartment	RESI FAR	Residential	Bungalow/ Dwelling / Non Apartment
				FIRST FLOOR PLAN	Residential	Bungalow/ Dwelling / Non Apartment	RESI FAR	Residential	Bungalow/ Dwelling / Non Apartment
				TERRACE FLOOR PLAN	Residential	Bungalow/ Dwelling / Non Apartment	-	-	-

UnitBUA Table for Building :ANKIT KUMAR (BUILDING)						
FLOOR	Name	UnitBUA Type	UnitBUA Area	Carpet Area	No. of Rooms	No. of Tenement
GROUND FLOOR PLAN	SPLIT ANKIT	FLAT	118.93	117.52	6	1
FIRST FLOOR PLAN	SPLIT ANKIT	FLAT	0.00	0.00	7	0
Total:	-	-	118.93	117.52	13	1

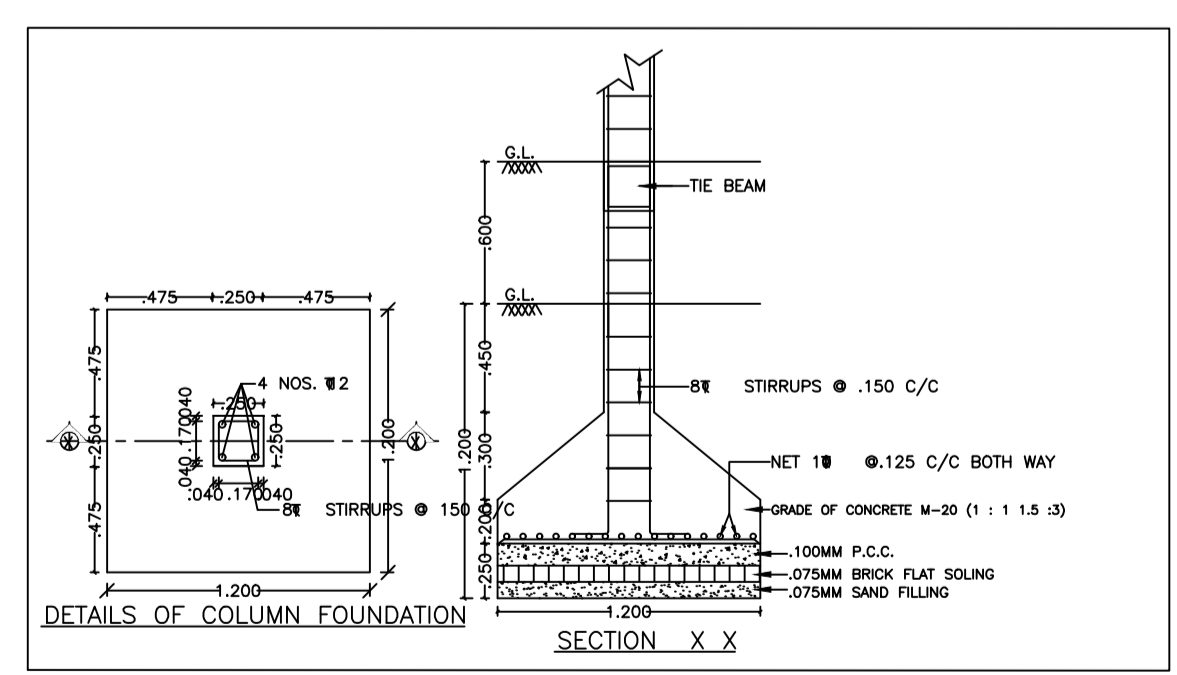
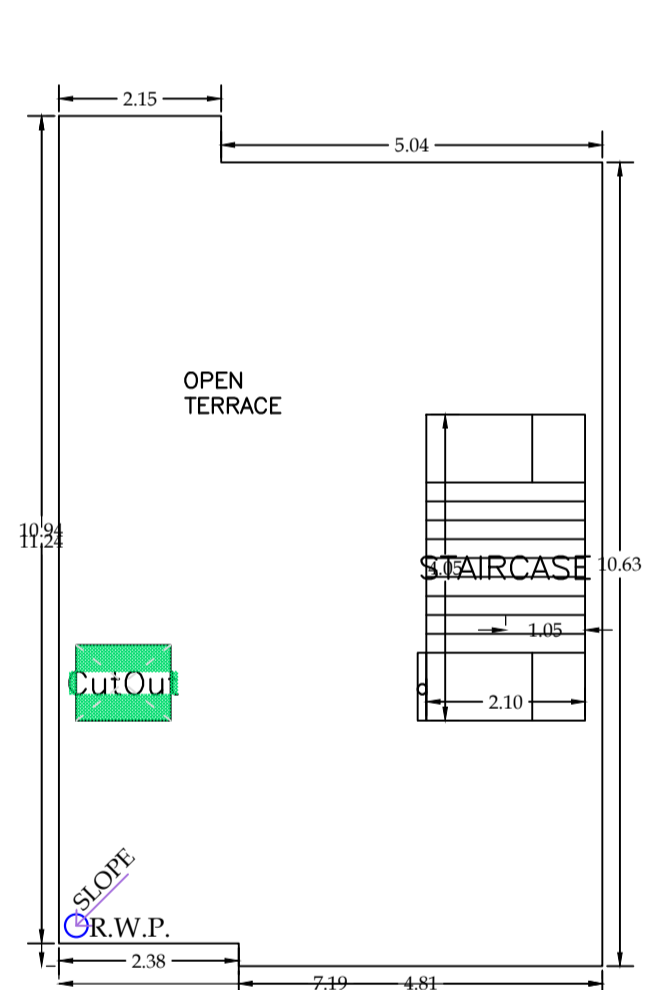
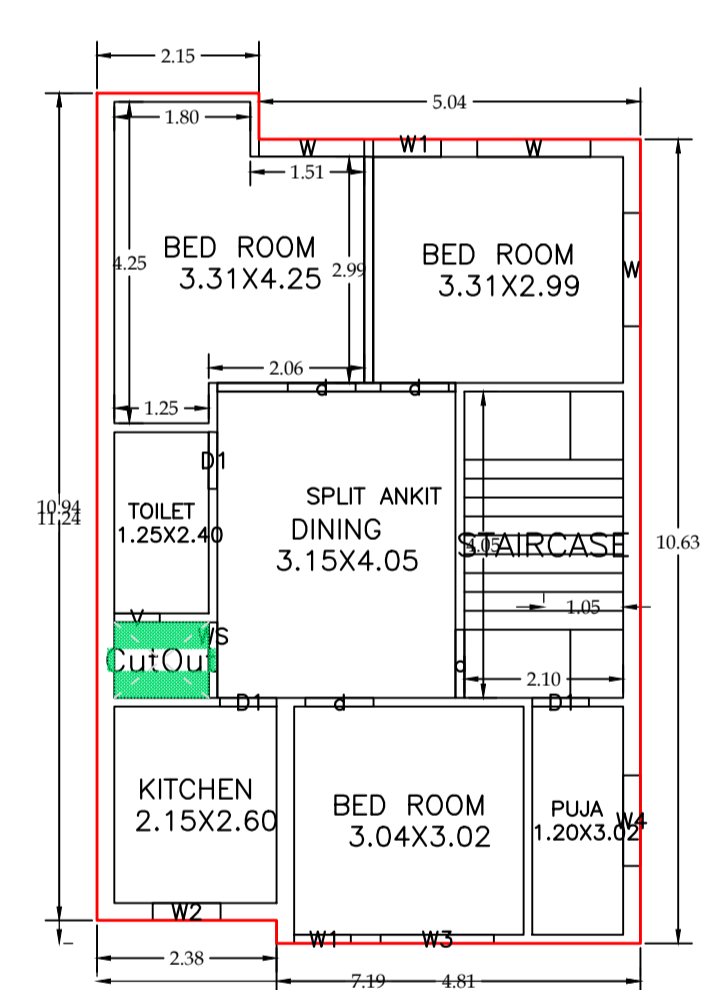
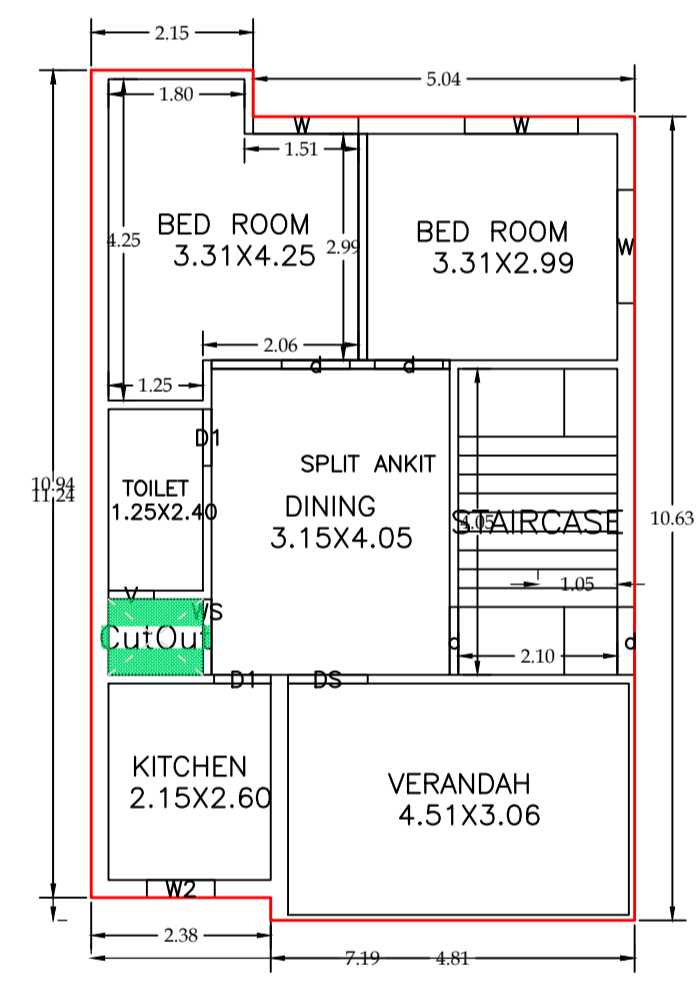
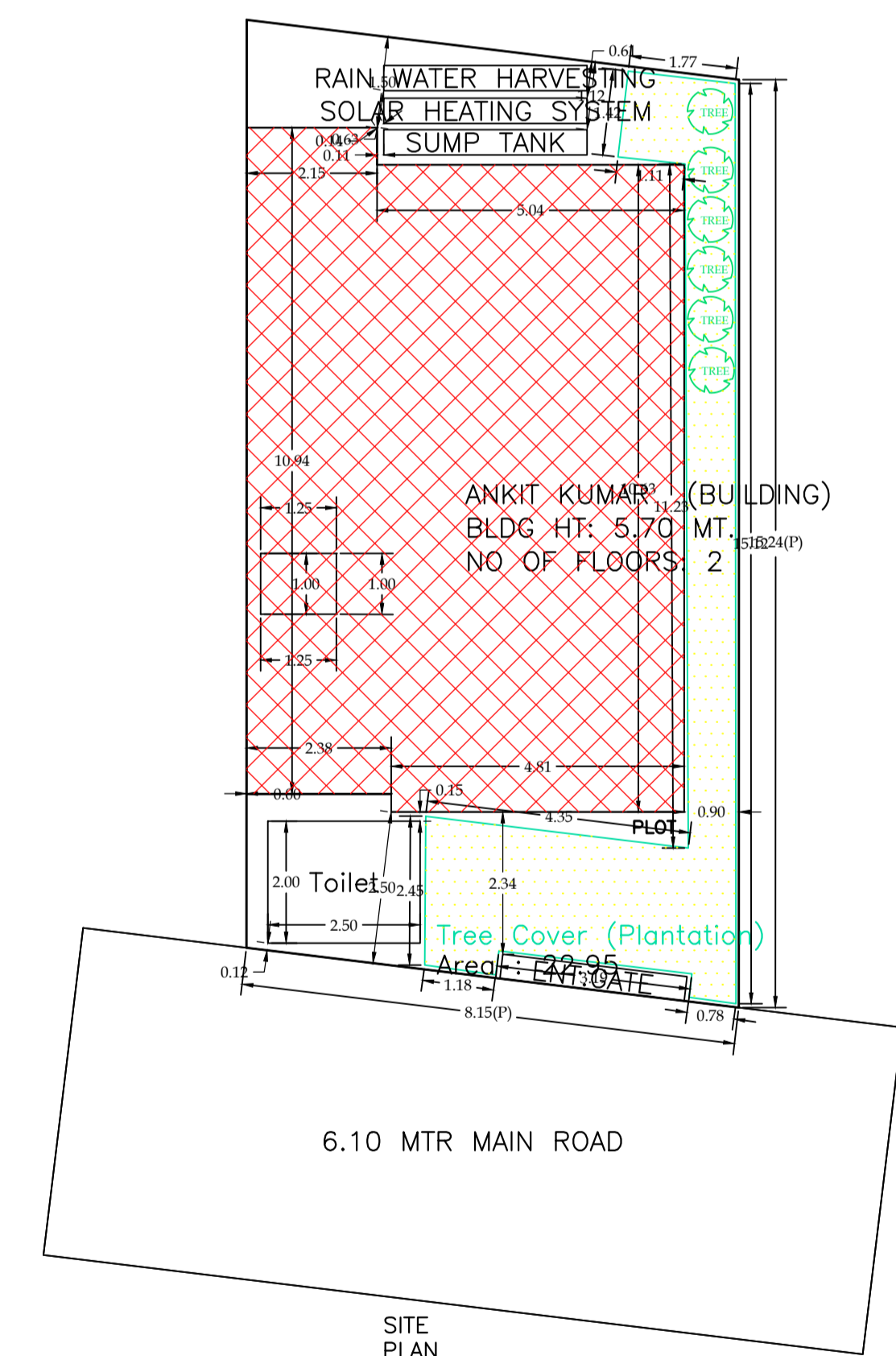
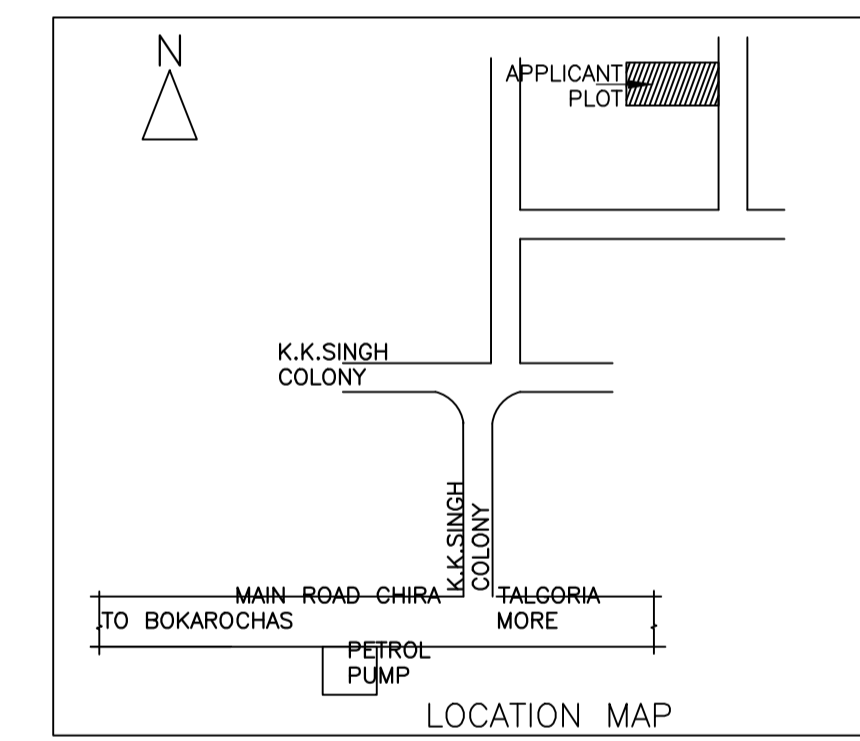
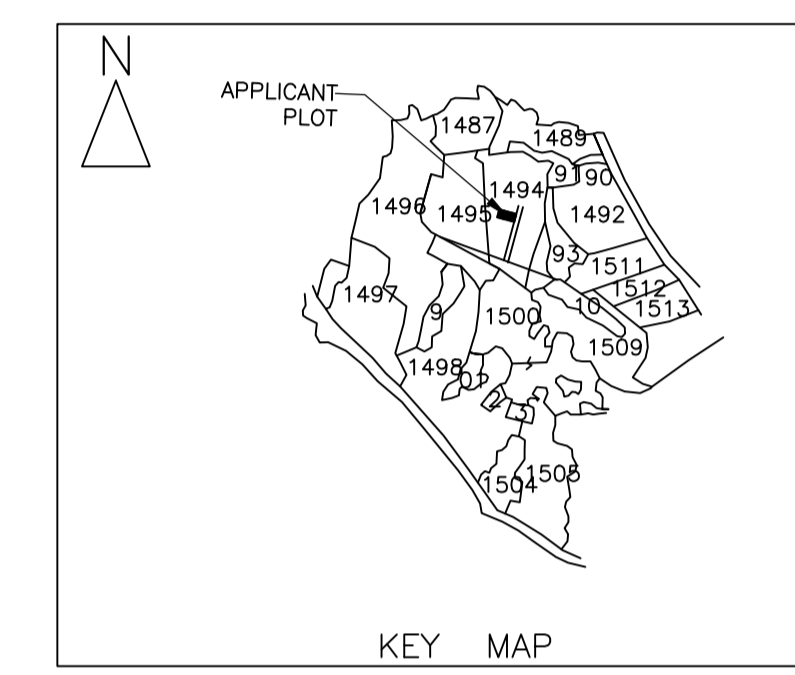
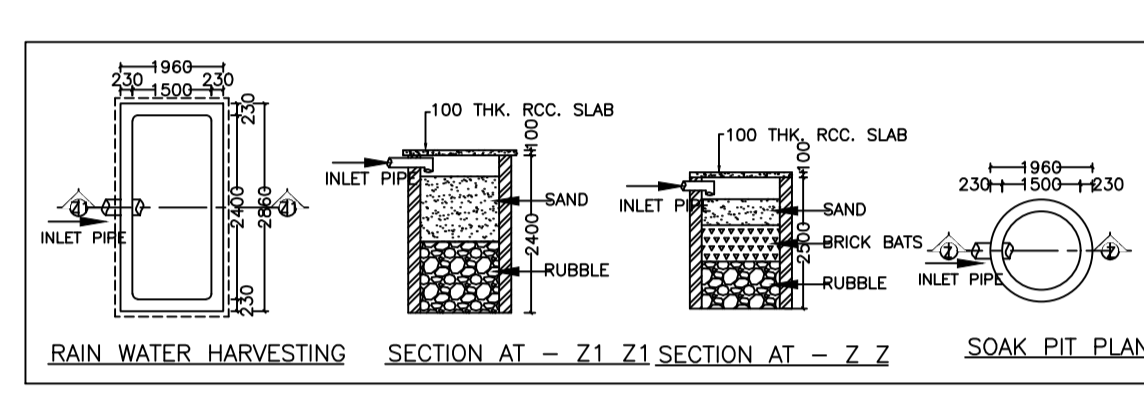
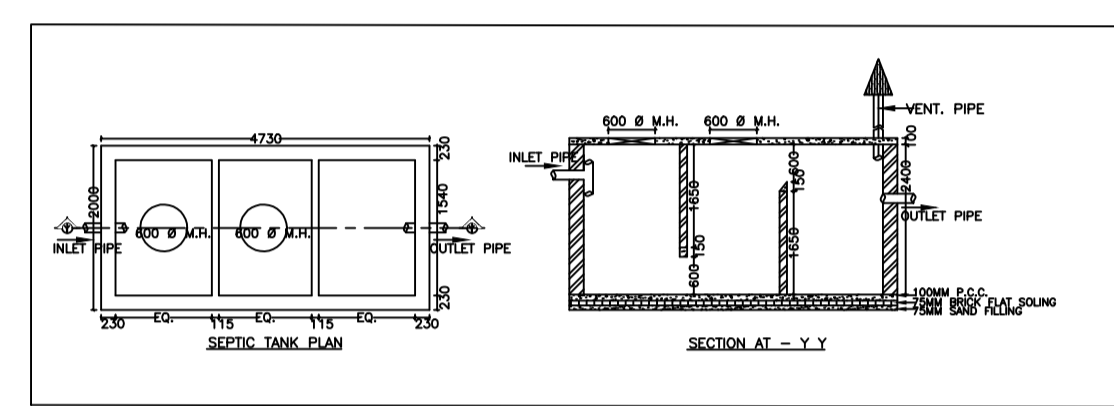
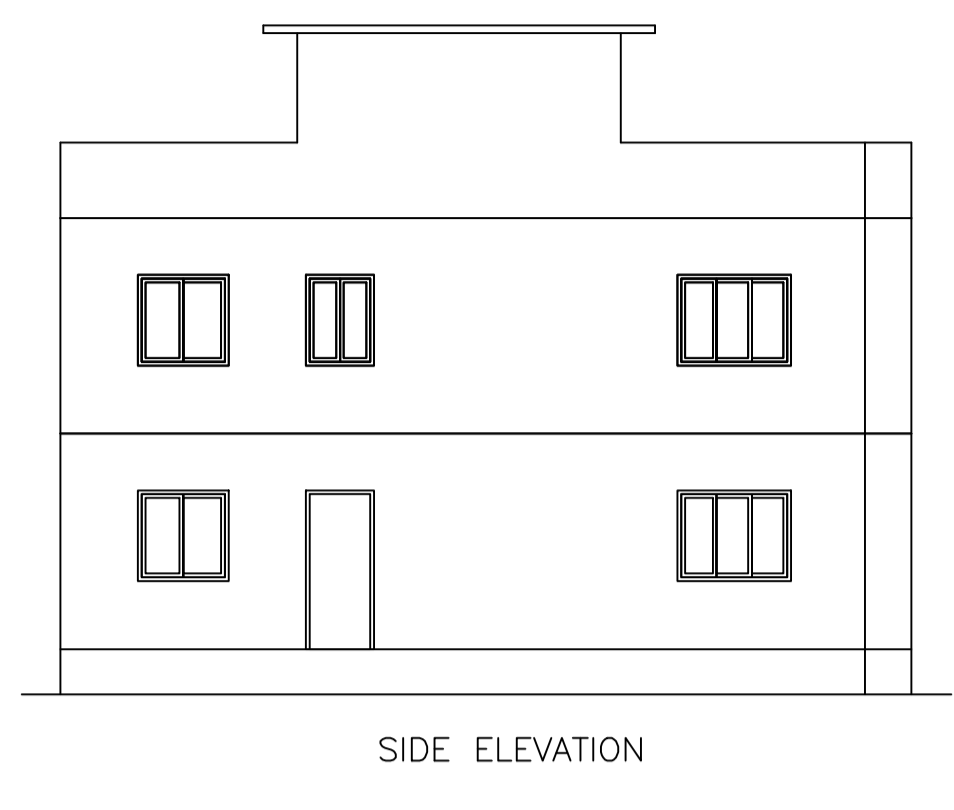
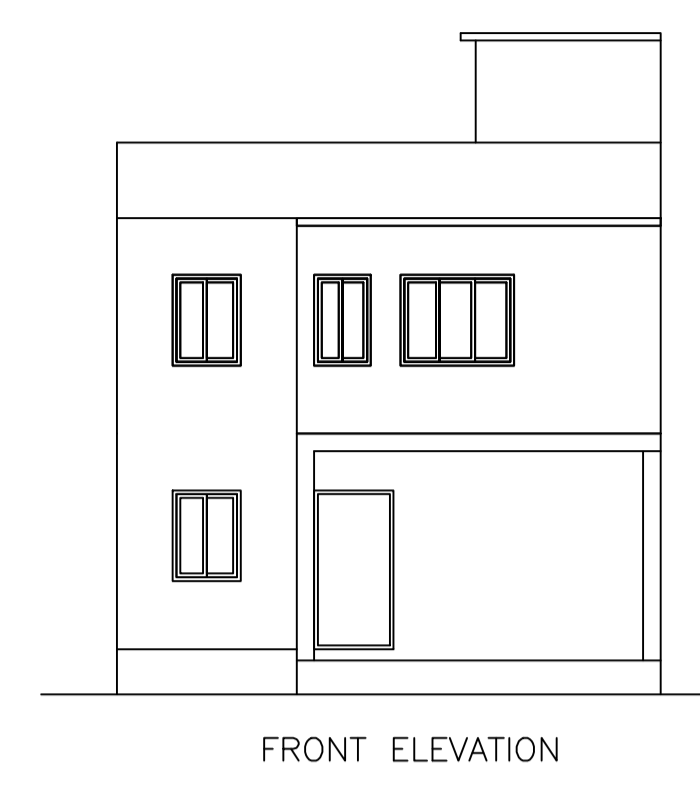
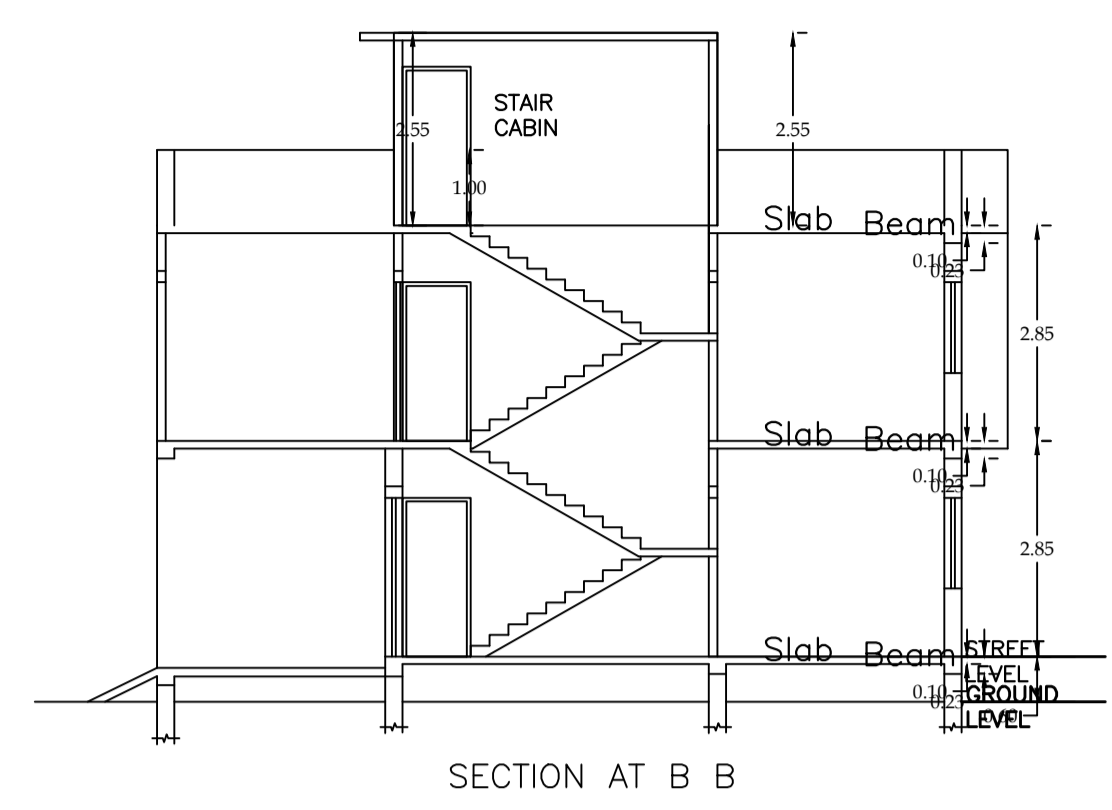
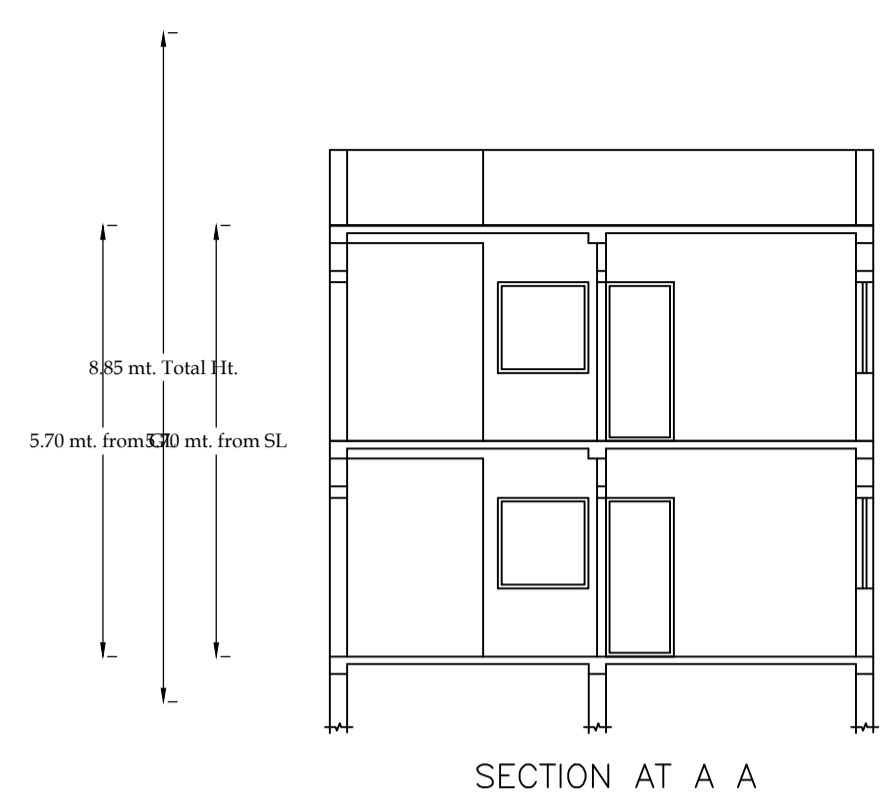

SCHEDULE OF WINDOW/VENTILATION:				
BUILDING NAME	NAME	LENGTH	HEIGHT	NOS
ANKIT KUMAR (BUILDING)	V	0.60	0.90	02
ANKIT KUMAR (BUILDING)	W1	0.75	2.10	01
ANKIT KUMAR (BUILDING)	W2	0.90	1.20	02
ANKIT KUMAR (BUILDING)	W1	0.90	2.10	01
ANKIT KUMAR (BUILDING)	WS	1.00	2.10	02
ANKIT KUMAR (BUILDING)	W4	1.20	1.20	01
ANKIT KUMAR (BUILDING)	W	1.39	1.20	02
ANKIT KUMAR (BUILDING)	W	1.50	1.20	04
ANKIT KUMAR (BUILDING)	W3	1.50	1.20	01

SCHEDULE OF DOOR:				
BUILDING NAME	NAME	LENGTH	HEIGHT	NOS
ANKIT KUMAR (BUILDING)	D1	0.75	2.10	05
ANKIT KUMAR (BUILDING)	d	0.90	2.10	07
ANKIT KUMAR (BUILDING)	DS	1.05	2.10	01

Building :ANKIT KUMAR (BUILDING)						
Floor Name	Gross Builtup Area	Deductions From Gross BU/A (Area in Sq.mt.)	Total Built Up Area (Sq.mt.)	Proposed FAR Area (Sq.mt.)	Total FAR Area (Sq.mt.)	Total Consumed Additional FAR Area (Sq.mt.)
Ground Floor	77.03	1.25	75.78	75.78	75.78	01
First Floor	77.03	1.25	75.78	75.78	75.78	00
Terrace Floor	0.00	0.00	0.00	0.00	0.00	00
Total	154.06	2.50	151.56	151.56	151.56	01
Total Number of Same Buildings	1					
Total :	154.06	2.50	151.56	151.56	151.56	01

FAR & Tenement Details (Table 4c-1)						
Building	No. of Same Bldg	Gross Built Up Area (Sq.mt.)	Deductions From Gross BU/A (Area in Sq.mt.)	Total Built Up Area (Sq.mt.)	Proposed FAR Area (Sq.mt.)	Total FAR Area (Sq.mt.)
ANKIT KUMAR (BUILDING)	1	154.06	2.50	151.56	151.56	151.56
Grand Total :	1	154.06	2.50	151.56	151.56	151.56

LTP NAME AND SIGNATURE	STRUCTURAL ENG'S NAME AND SIGNATURE	BUILDER NAME AND SIGNATURE	DIGITAL SIGNATURE
PANKAJ GUPTA CMC/ENG/0018/2022			