

Proposal Basic Information	
Proposal File No.	CMC/BP/0099/W04/2024
Owner Name	JAI PRAKASH NARAYAN
Khata No.	1
Plot No.	1494
Village Name	Chas
Use	Residential
SubUse	Bungalow/ Dwelling / Non Apartment

AREA STATEMENT CHAS MUNICIPAL CORPORATION		VERSION NO. : 1.0.70
PROJECT DETAIL:		VERSION DATE: 16/10/2020
Region: JHARKHAND URBAN LOCAL BODIES	Plot Use: Residential	SQ. MT.
District: BOKARO	Plot SubUse: Bungalow/ Dwelling / Non Apartment	
Authority: CHAS MUNICIPAL CORPORATION	PlotNearbyReligiousStructure: NA	
Inward_No: CMC/BP/0099/W04/2024	PlotSubPlot No: 1494	
Application Type: General Proposal	North: Road Width - 6.10 M ROAD	
Project Type: Building Permission	South: Plot No. - PART OF SALE PLOT	
Nature of Development: New	East: Road Width - 6.10 M ROAD	
Location of Development Area: Old Area	West: Plot No. - SONI DEVI	
AREA DETAILS:		
AREA OF PLOT (Minimum)	(A)	206.80
NET AREA OF PLOT(Gross Plot Area - Deduction from Gross Plot area)	(A-Deductions)	206.80
Deduction for Balance Plot Area(from Gross Plot Area)		
Common Plot		35.52
Total		35.52
BALANCE AREA OF PLOT(Net Plot Area - Recreational/Amenity space)	(A-Deductions)	171.29
PLOT AREA FOR COVERAGE(Net Plot Area)	(A-Deductions)	206.80
Plot Area for FAR (Net Plot Area + Road/Widening Area)	(A-Deductions)	206.80
COVERAGE CHECK		
Permissible Coverage area (70.00 %)		144.76
Proposed Coverage Area (56.88 %)		117.63
Total Prop. Coverage Area (56.88 %)		117.63
Balance coverage area (13.12 %)		27.13
FAR CHECK		
Perm. FAR Area (2.500)		517.00
Total Perm. FAR area		517.00
Residential FAR		214.72
Proposed FAR Area		214.72
Total Proposed FAR Area		214.72
Consumed FAR (Factor)		1.04
Balance FAR Area		302.28
BUILT UP AREA CHECK		
Total Proposed BuiltUp Area		214.71
ARCHITECT (Regd)		RAVI KUMAR
ENGINEER (Regd)		
SUPERVISOR (Regd)		
OWNER (Regd)		JAI PRAKASH NARAYAN
DEVELOPMENT AUTHORITY LOCAL BODY		

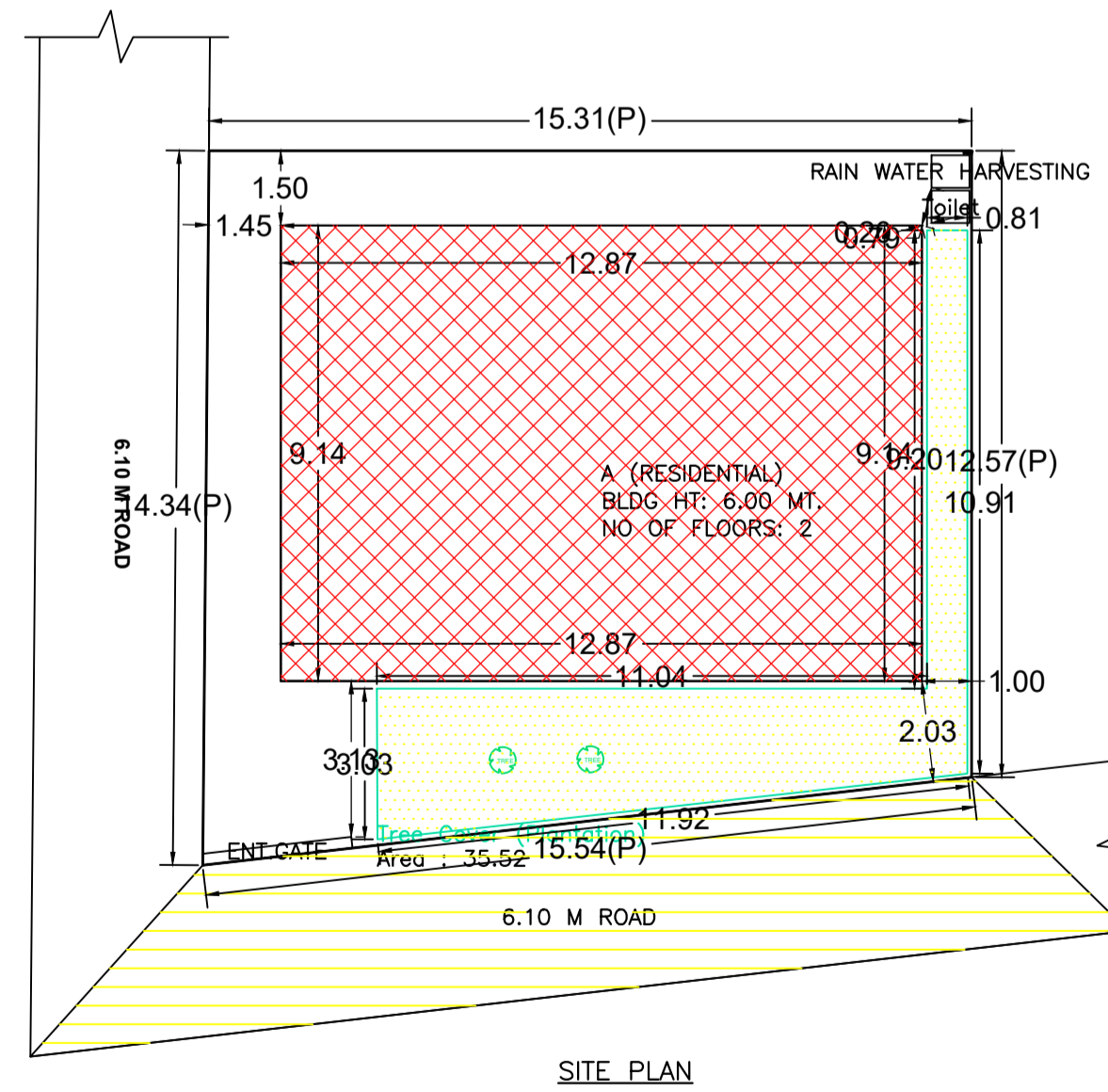
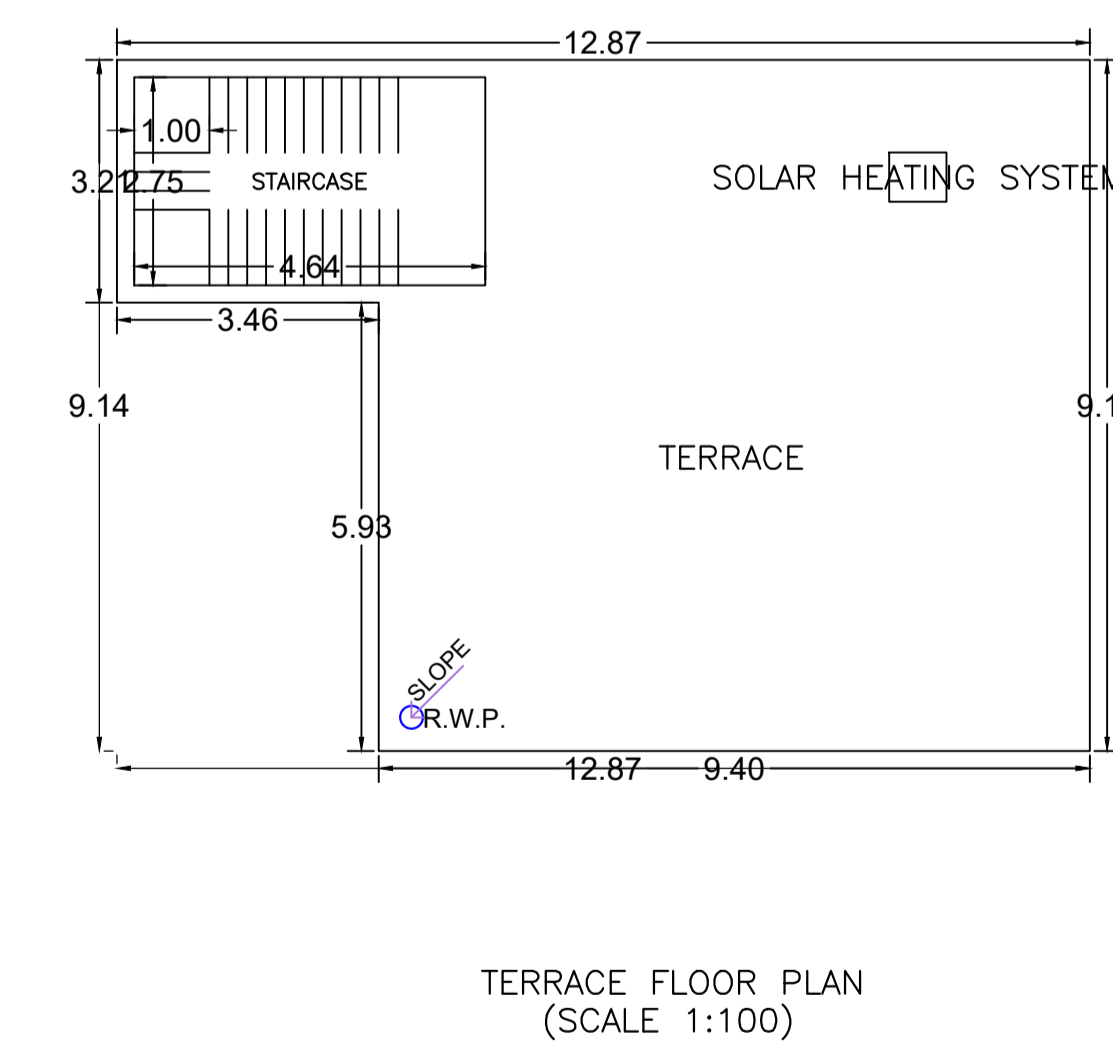
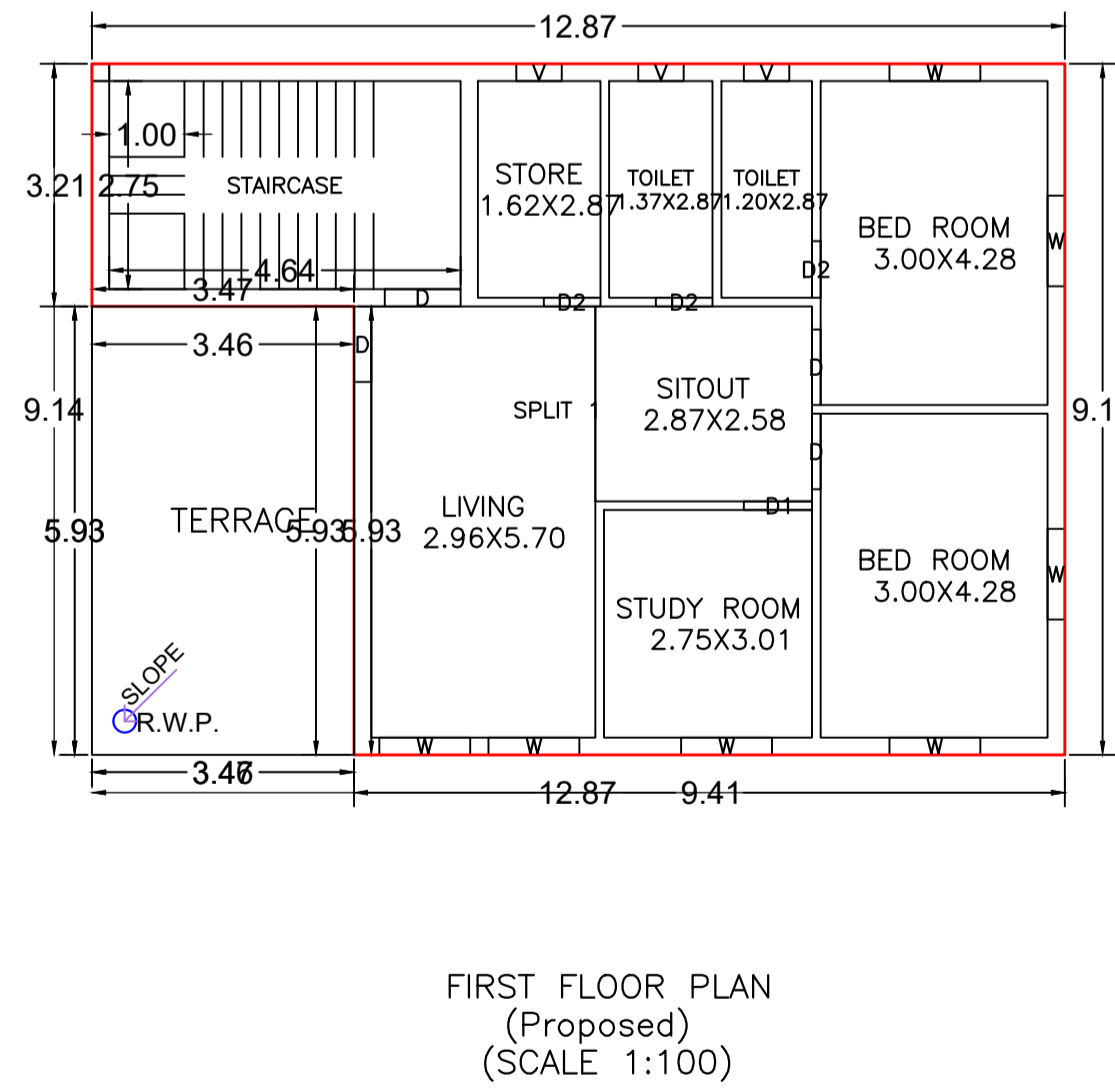
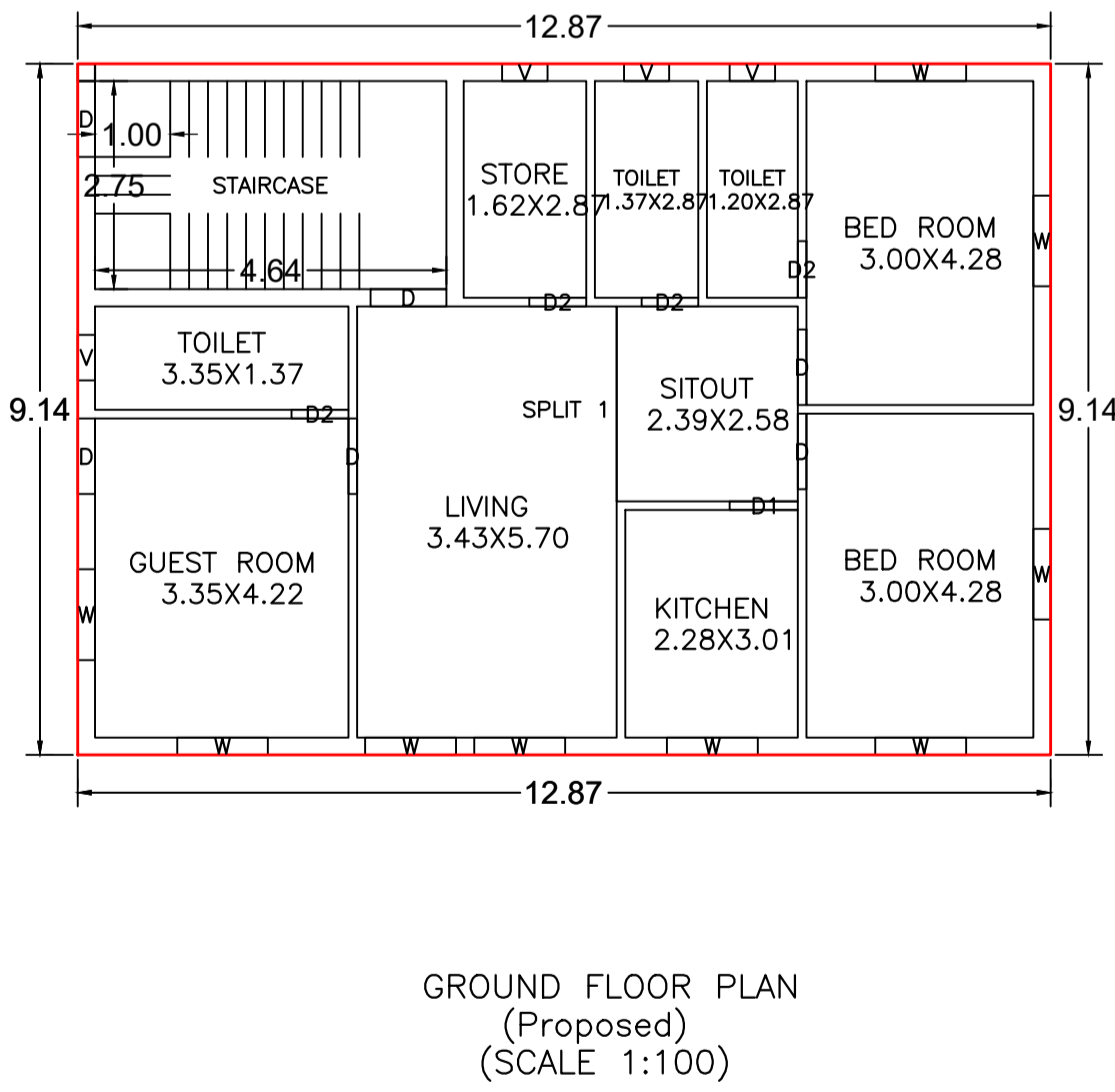
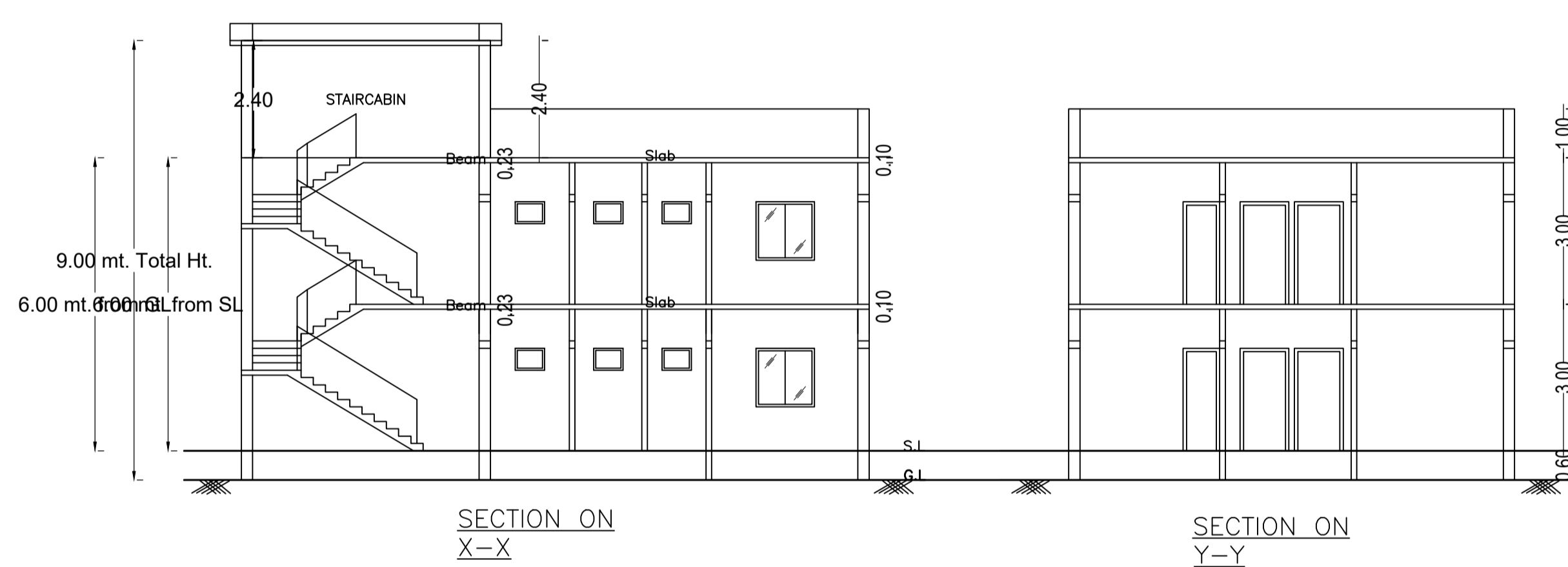
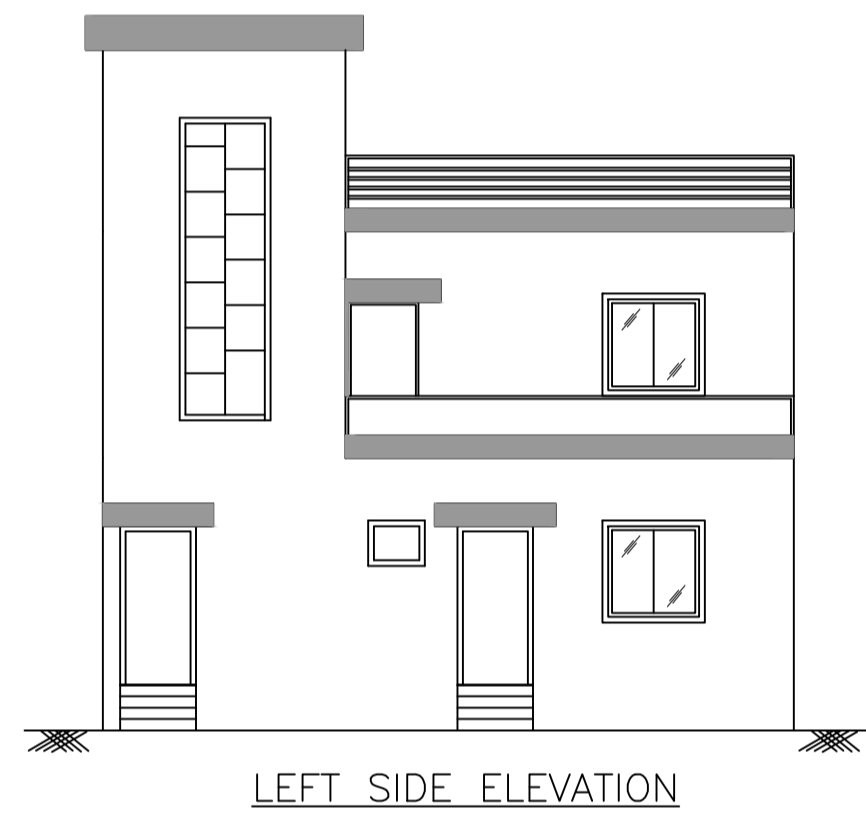
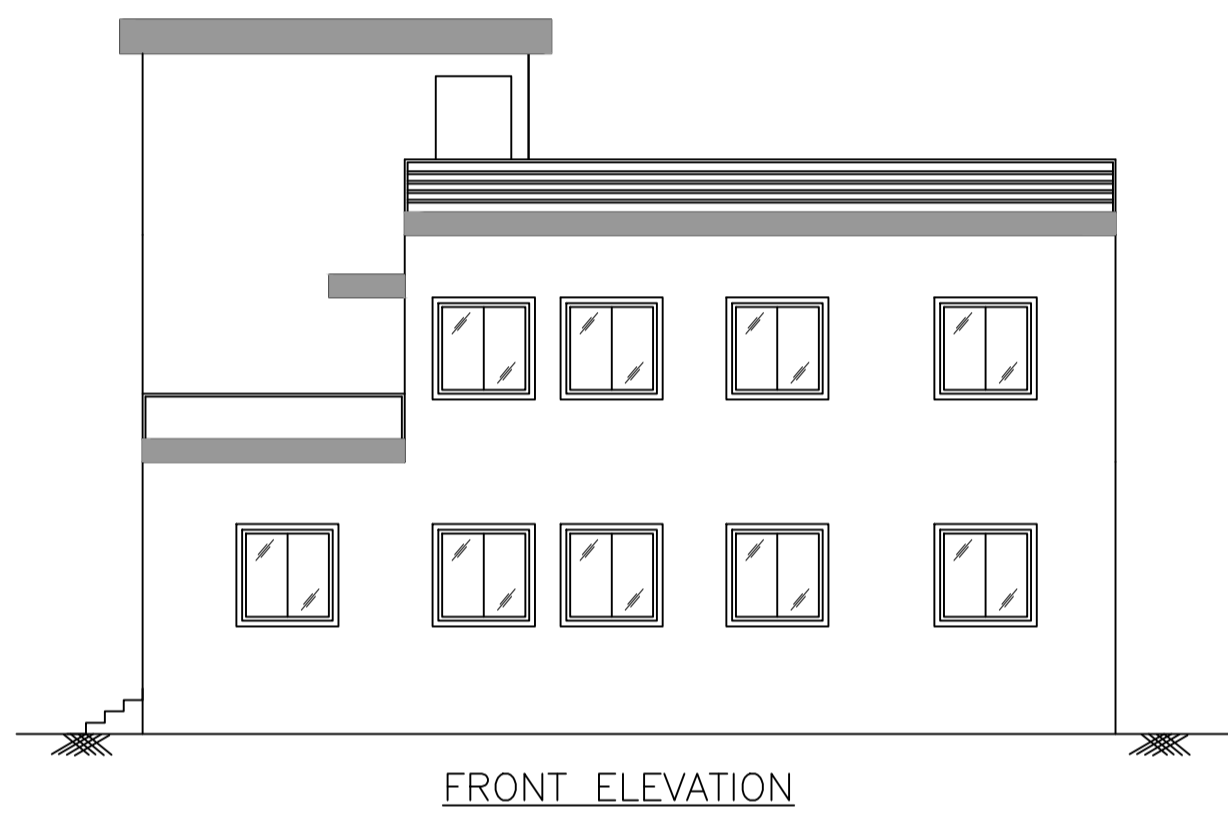

Floor Name	Total Built Up Area (Sq.mt.)	Proposed FAR Area (Sq.mt.) Resi.	Total FAR Area (Sq.mt.)	Total Consumed Additional FAR Area (Sq.mt.)	Tnmt (No.)
Ground Floor	117.63	117.63	117.63	117.63	01
First Floor	97.08	97.08	97.08	97.08	00
Terrace Floor	0.00	0.00	0.00	0.00	00
Total:	214.71	214.71	214.71	214.71	01

Floor Name	Building Name A (RESIDENTIAL)		Total	
	Proposed Built Up Area (Sq.mt.)	Proposed FAR Area (Sq.mt.)	Total Proposed Built Up Area (Sq.mt.)	Total FAR Area (Sq.mt.)
Ground Floor	117.63	117.63	117.63	117.63
First Floor	97.08	97.08	97.08	97.08
Terrace Floor	0.00	0.00	0.00	0.00
Total:	214.71	214.71	214.71	214.71

Building	No. of Same Bldg	Total Built Up Area (Sq.mt.)	Proposed FAR Area (Sq.mt.) Resi.	Total FAR Area (Sq.mt.)	Total Consumed Additional FAR Area (Sq.mt.)	Tnmt (No.)
A (RESIDENTIAL)	1	214.71	214.71	214.71	214.71	01
Grand Total:	1	214.71	214.71	214.71	214.71	01

FLOOR	Name	UnitBUA Type	UnitBUA Area	Carpet Area	No. of Rooms	No. of Tenement
GROUND FLOOR PLAN	SPLIT 1	FLAT	214.72	214.61	10	1
FIRST FLOOR PLAN	SPLIT 1	FLAT	0.00	0.00	8	0
Total:	-	-	214.72	214.61	18	1

SCHEDULE OF DOOR:

BUILDING NAME	NAME	LENGTH	HEIGHT	NOS
A (RESIDENTIAL)	D2	0.75	2.10	07
A (RESIDENTIAL)	D1	0.90	2.10	02
A (RESIDENTIAL)	D	1.00	2.10	09

SCHEDULE OF WINDOW/VENTILATION:

BUILDING NAME	NAME	LENGTH	HEIGHT	NOS
A (RESIDENTIAL)	V	0.60	1.20	07
A (RESIDENTIAL)	W	1.20	1.20	16

Building USE/SUBUSE Details

Building Name	Building Use	Building SubUse	Building Structure
A (RESIDENTIAL)	Residential	Bungalow/ Dwelling / Non Apartment	Non-Highrise

COLOR INDEX

PLOT BOUNDARY	Black
ABUTTING ROAD	Red
PROPOSED CONSTRUCTION	Green
COMMON PLOT	Yellow
ROAD WIDENING AREA	Blue
EXISTING (To be retained)	Orange
EXISTING (To be demolished)	Purple

LTP NAME AND SIGNATURE	STRUCTURAL ENG'S NAME AND SIGNATURE	BUILDER NAME AND SIGNATURE	DIGITAL SIGNATURE
RAVI KUMAR CMC/DFTMN/0024/2017			