

Project Title : JAI PRAKASH NARAYAN

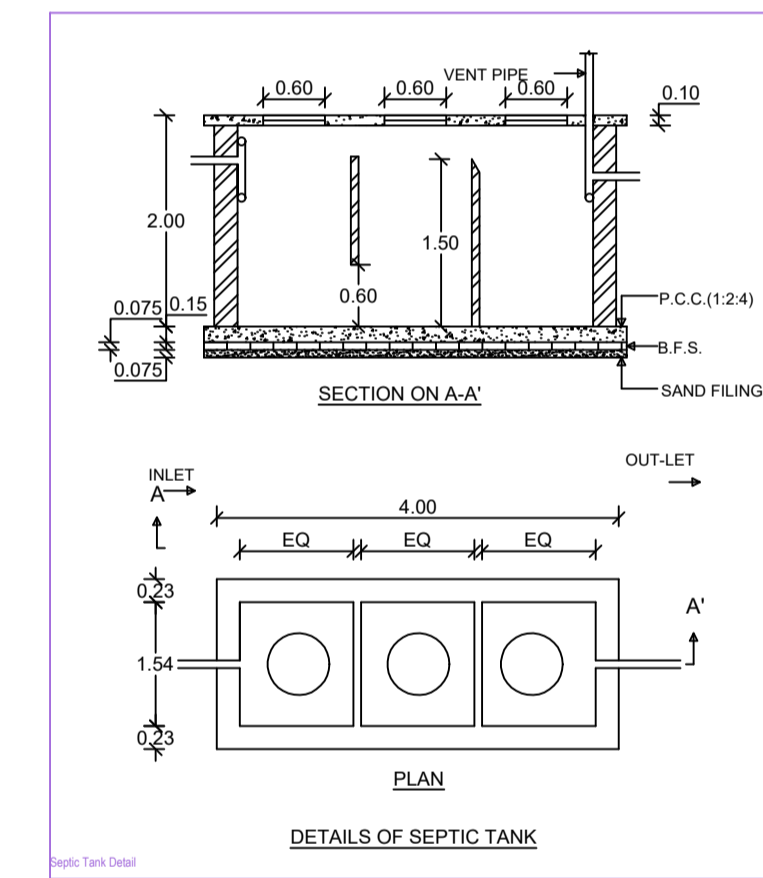
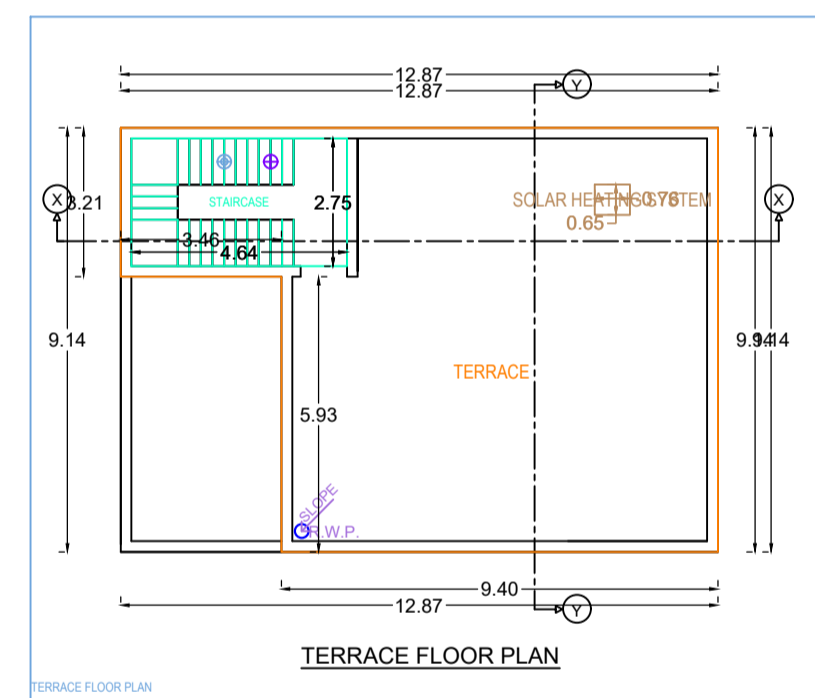
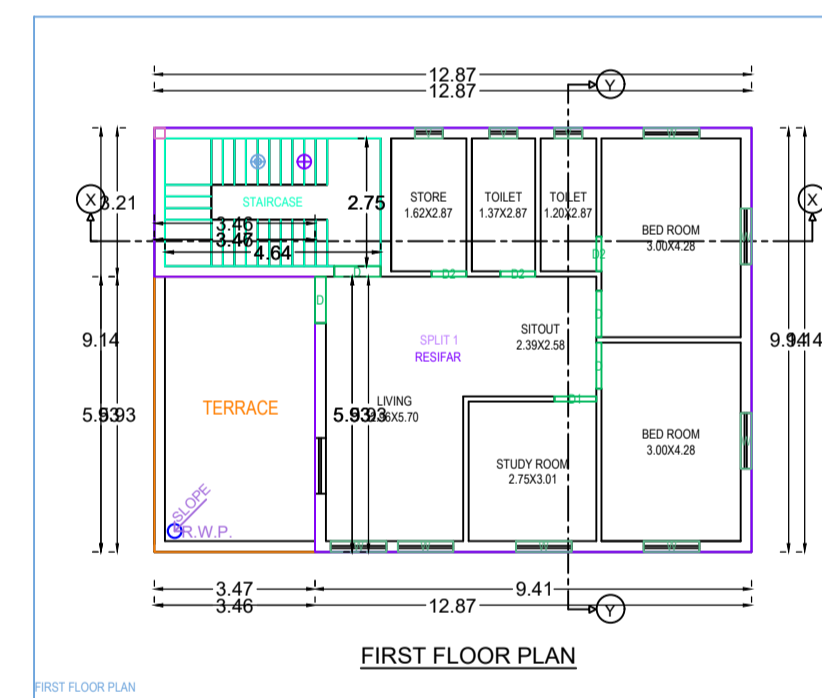
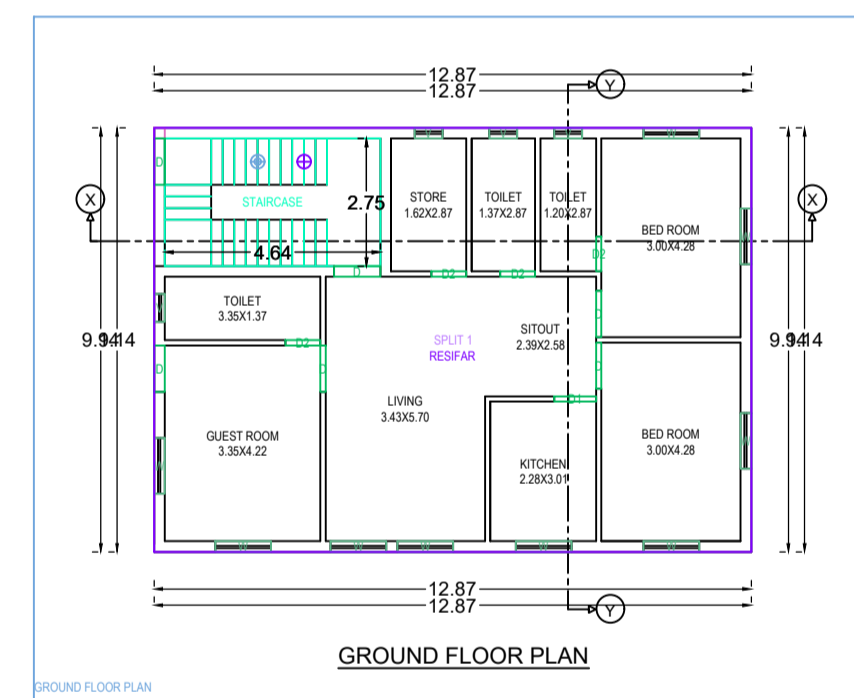
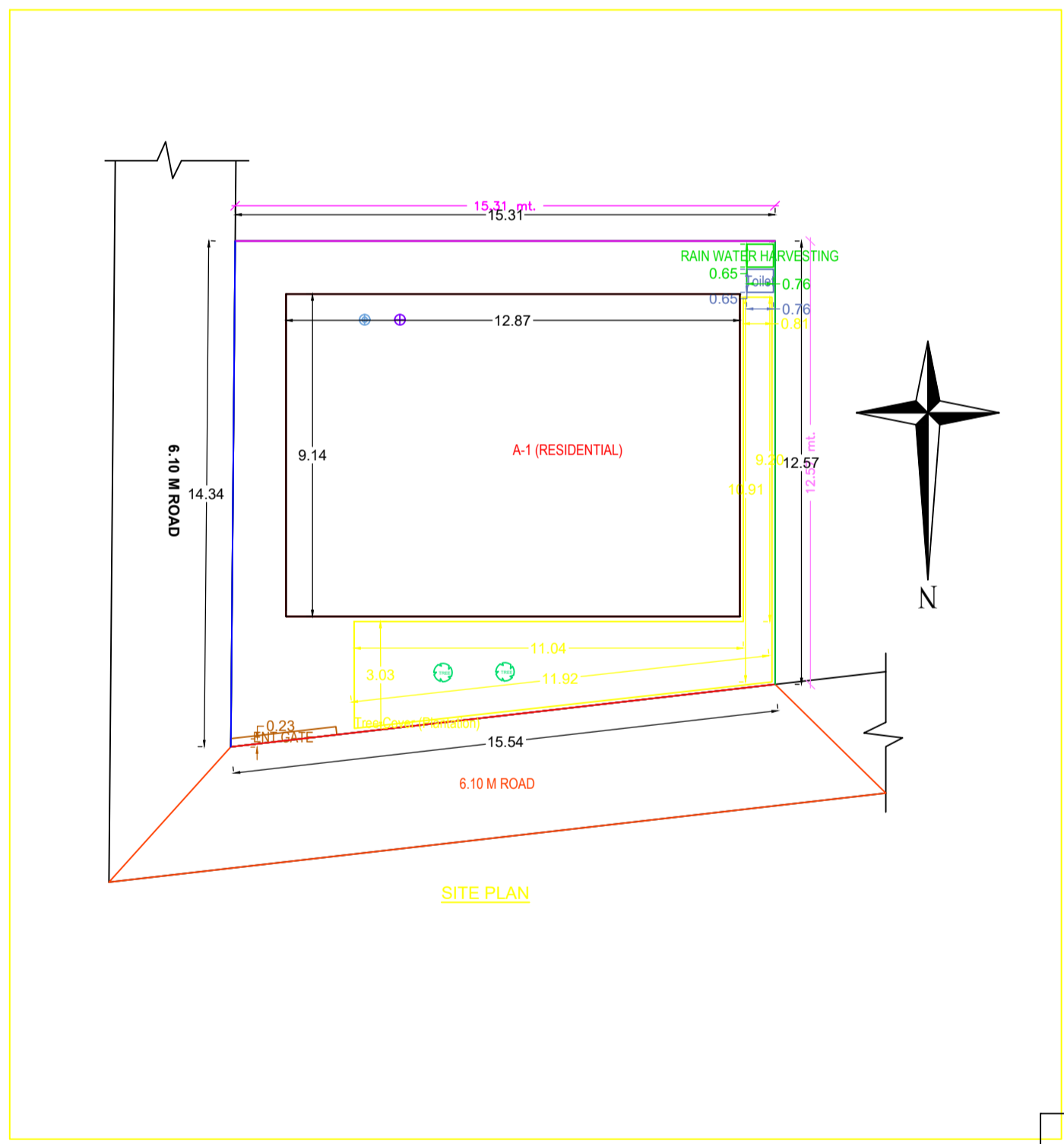
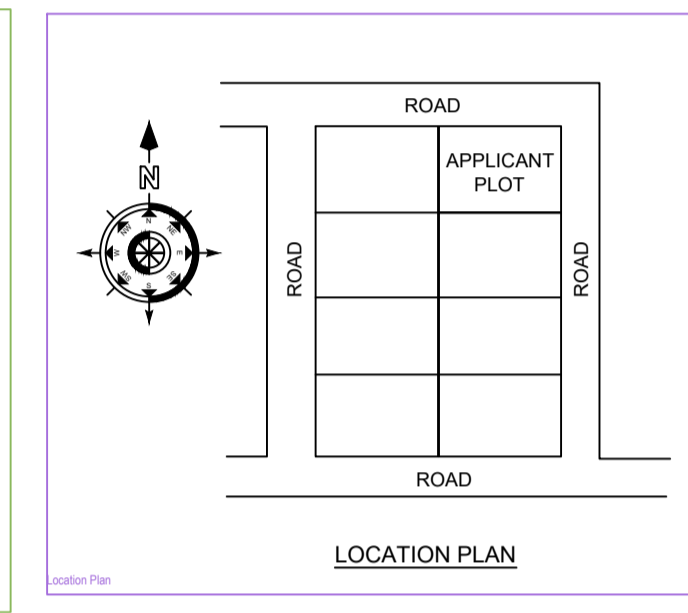
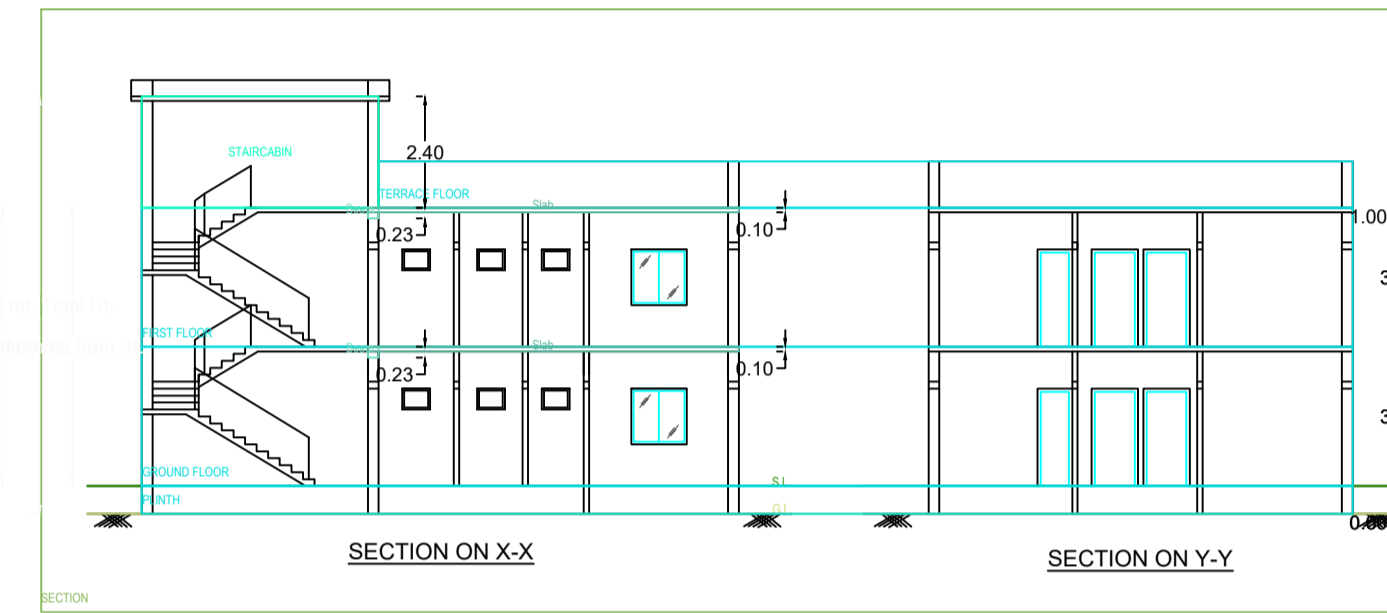
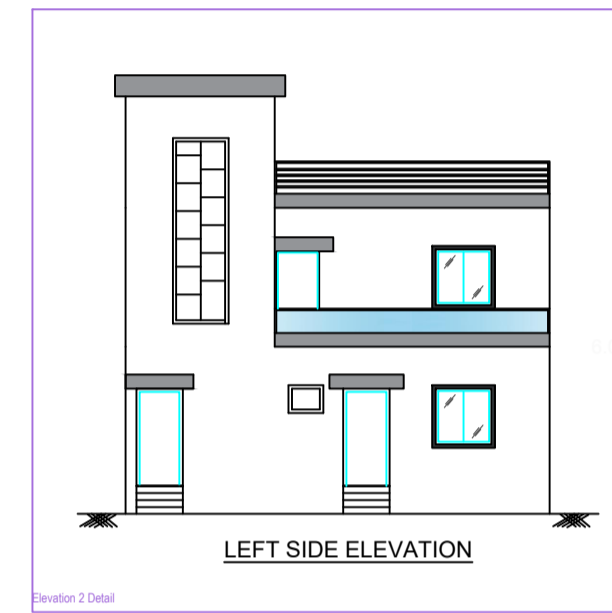
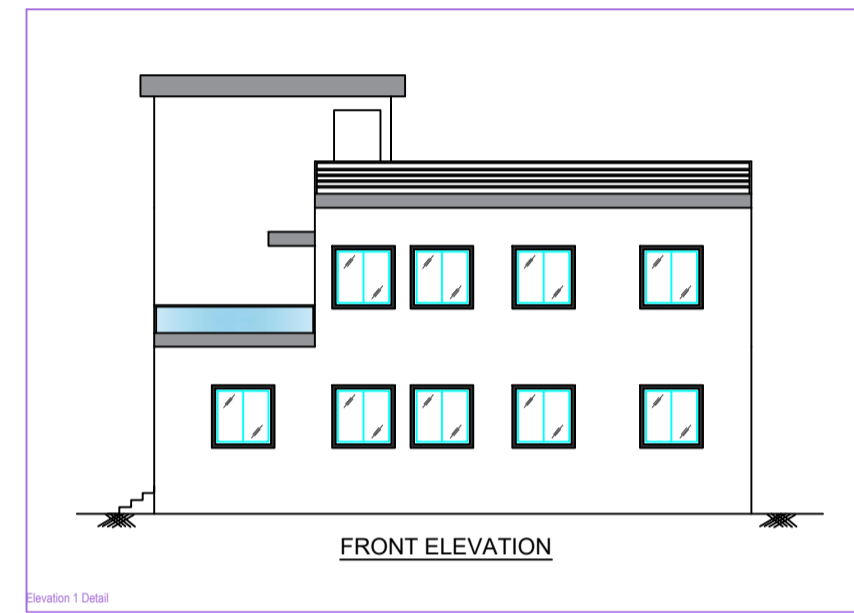
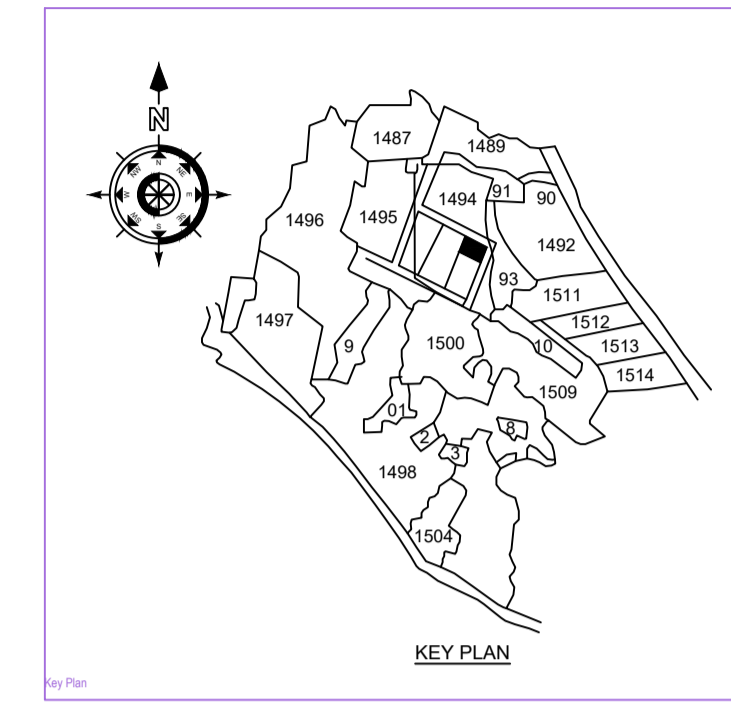
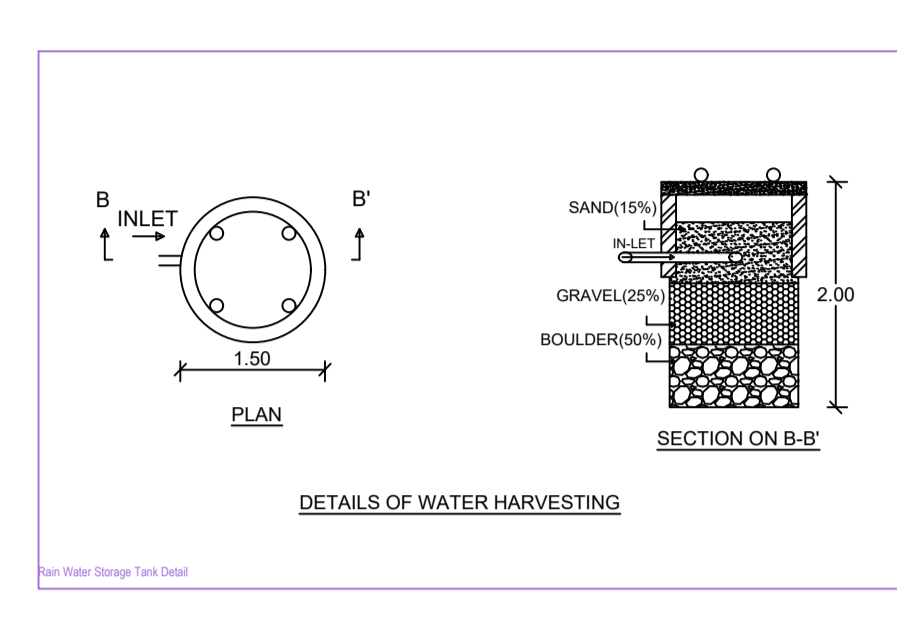
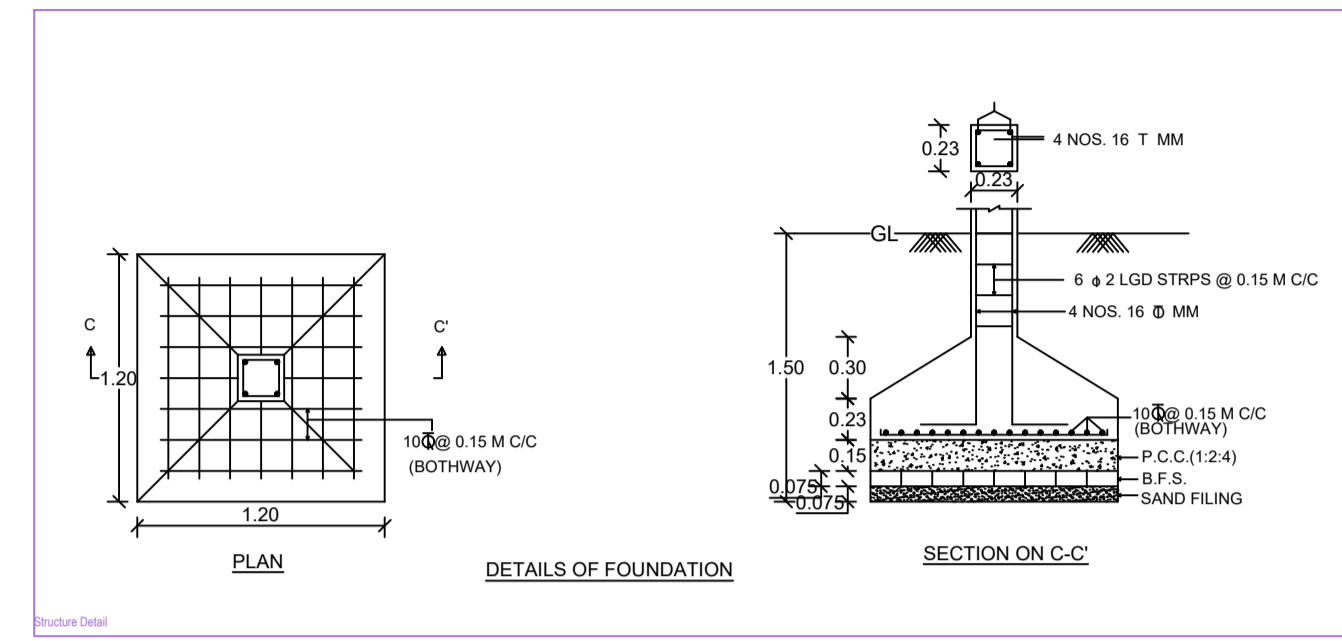

AREA STATEMENT: CHAS MUNICIPAL CORPORATION	VERSION NO.: 1.0.37
PROJECT DETAIL	VERSION DATE: 18/10/2020
Project No.:	Plot Use: Residential
Region: PUNJAB/ANDHRA PRADESH LOCAL BODIES	Plot Location: Bangalore Dwelling Min Apartment
District: BANGALORE	Land Use Zone: RA
Application Type: General Professional	Neighbourhood: West
Project Type: Building Permission	Plot No.:
Name of Development: New	Reference Survey No/Survey No.:
Location: 150 Area	Thana No.:
Sub Location: NA	Holding No.:
Wing/Area Name:	Phone No.:
Word No.:	North:
Road/Street:	South:
East:	West:

AREA DETAILS	ISQ MT.	206.80
AREA OF PLOT (Minimum)	(A)	206.80
Net Plot Area (Gross Plot Area - Deduction from Gross Plot Area)	(A Deductions)	206.80
Deductions for Balance Plot Area (from Gross Plot Area)		
Plot Area		35.32
Plot Area for FSI (Net Plot Area - Residential/Community zones)	(A Deductions)	111.29
Plot Area for Coverage (Net Plot Area)	(A Deductions)	206.80
Plot Area for FSI (Net Plot Area - Residential/Community zones)	(A Deductions)	206.80
Accessory/Use Area		0.00
COVERAGE CHECK		
Proposed Coverage Area (56.88 %)		117.63
Total Coverage Area (56.88 %)		117.63
FAR CHECK		
Proposed Area of FAR		214.71
Total Area of FAR		214.71
BUILT UP AREA CHECK		
Total Proposed Built Up Area		214.71
ARCHT. (ENGLG) SUPERVISOR (Sign)	OWNER	
DEVELOPMENT AUTHORITY	LOCAL BODY	

COLOR INDEX	
FLY BOUNDARY	█
ADJUTING ROAD	█
PROPOSED WORK (COVERAGE AREA)	█
EXISTING (To be retained)	█
EXISTING (To be demolished)	█

MARGIN DETAIL:					
Building / Wing Name	Road Name	Front Margin	Rear Margin	Side Margin	Side Margin
A1 (RESIDENTIAL)	6.10 M ROAD	2.03	1.50	1.45	1.00

FAR & Tenement Details (Table 4c-1)					
Building	No. of Same Bldg	Total Built Up Area (Sq.mt)	Proposed FAR Area (Sq.mt)	Total FAR Area (Sq.mt)	Tenent (No.)
A (RESIDENTIAL)	1	214.71	214.71	214.71	01
Grand Total	1	214.71	214.71	214.71	01

A (RESIDENTIAL)

Building - A (RESIDENTIAL)					
Floor Name	Total Built Up Area (Sq.mt)	Proposed FAR Area (Sq.mt)	Total FAR Area (Sq.mt)	Tenent (No.)	
Ground Floor	117.63	117.63	117.63	01	
First Floor	97.08	97.08	97.08	01	
Terrace Floor	0.00	0.00	0.00	00	
Total	214.71	214.71	214.71	01	
Total Number of Same Buildings	1				
Total	214.71	214.71	214.71	01	

SCHEDULE OF JOINERY:					
BUILDING NAME	NAME	LENGTH	HEIGHT	NOS	
A (RESIDENTIAL)	G1	5.76	2.10	07	
A (RESIDENTIAL)	G1	5.90	2.10	02	
A (RESIDENTIAL)	G1	1.00	2.10	10	
Total				19	

SCHEDULE OF JOINERY:					
BUILDING NAME	NAME	LENGTH	HEIGHT	NOS	
A (RESIDENTIAL)	V	0.60	1.50	07	
A (RESIDENTIAL)	W	1.00	1.20	16	
Total				23	

UnitBUA Table for Building - A (RESIDENTIAL)						
FLOOR	Name	UnitBUA Type	UnitBUA Area	Carpet Area	No. of Rooms	No. of Tenement
GROUND FLOOR PLAN	SPLIT 1	FLAT	214.72	214.61	10	1
Total			214.72	214.61	10	1