

Proposal Basic Information

Proposal File No.	CMC/BP/0118/W05/2024
Owner Name	SAMIR KUMAR RAUT
Khata No	01
Plot No	1402
Village Name	Jamgoria
Use	Residential
SubUse	Bungalow/ Dwelling / Non Apartment

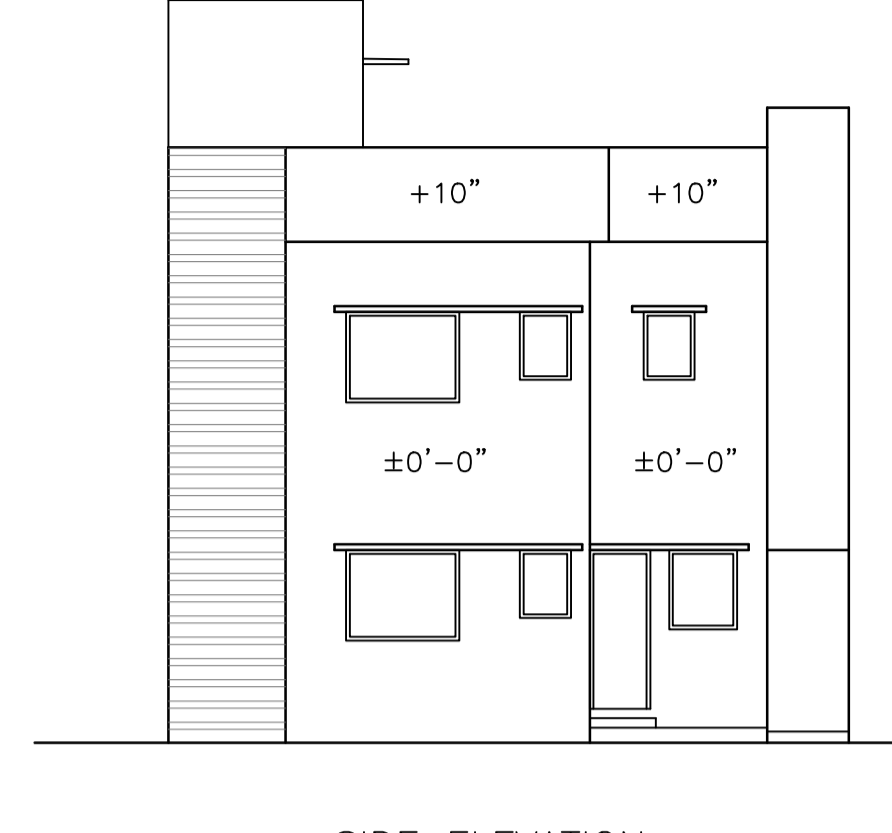

AREA STATEMENT CHAS MUNICIPAL CORPORATION	VERSION NO: 1.0.73	SQ. MT.
PROJECT DETAIL:	VERSION DATE: 16/10/2020	
Region: JHARKHAND URBAN LOCAL BODIES	Plot Use: Residential	
District: BOKARO	Plot SubUse: Bungalow/ Dwelling / Non Apartment	
Authority: CHAS MUNICIPAL CORPORATION	PlotNearbyReligiousStructure: NA	
Inward No: CMC/BP/0118/W05/2024	PlotSubPlot No: 1402	
Application Type: General Proposal	North: Road Width - 9.14 MTR WIDEROAD	
Project Type: Building Permission	South: Plot No. - PLOTTING A/24	
Nature of Development: New	East: Plot No. - PLOTTING A/22	
Location of Development Area: New Area	West: Road Width - 7.25 MTR WIDE ROAD	
AREA DETAILS:		
AREA OF PLOT (Minimum)	(A)	139.29
NET AREA OF PLOT(Gross Plot Area - Deduction from Gross Plot area)	(A-Deductions)	139.29
Deduction for Balance Plot Area(from Gross Plot Area)		
Common Plot		10.97
Total		10.97
BALANCE AREA OF PLOT(Net Plot Area - Recreational/Amenity space)	(A-Deductions)	128.32
PLOT AREA FOR COVERAGE(Net Plot Area)	(A-Deductions)	139.29
Plot Area for FAR (Net Plot Area + Road Widening Area)	(A-Deductions)	139.29
COVERAGE CHECK		
Permissible Coverage area (70.00 %)		97.50
Proposed Coverage Area (55.22 %)		76.92
Total Prop. Coverage Area (55.22 %)		76.92
Balance coverage area (14.77 %)		20.58
FAR CHECK		
Perm. FAR Area (2.500)		348.22
Total Perm. FAR area		348.22
Residential FAR		146.25
Proposed FAR Area		146.25
Total Proposed FAR Area		146.25
Consumed FAR (Factor)		1.05
Balance FAR Area		201.97
BUILT UP AREA CHECK		
Total Proposed BuiltUp Area		146.25
ARCHITECT (Regd)		MOHAMMED AZIZULLAH
ENGINEER (Regd)		
SUPERVISOR (Regd)		
OWNER (Regd)		SAMIR KUMAR RAUT
DEVELOPMENT AUTHORITY		LOCAL BODY

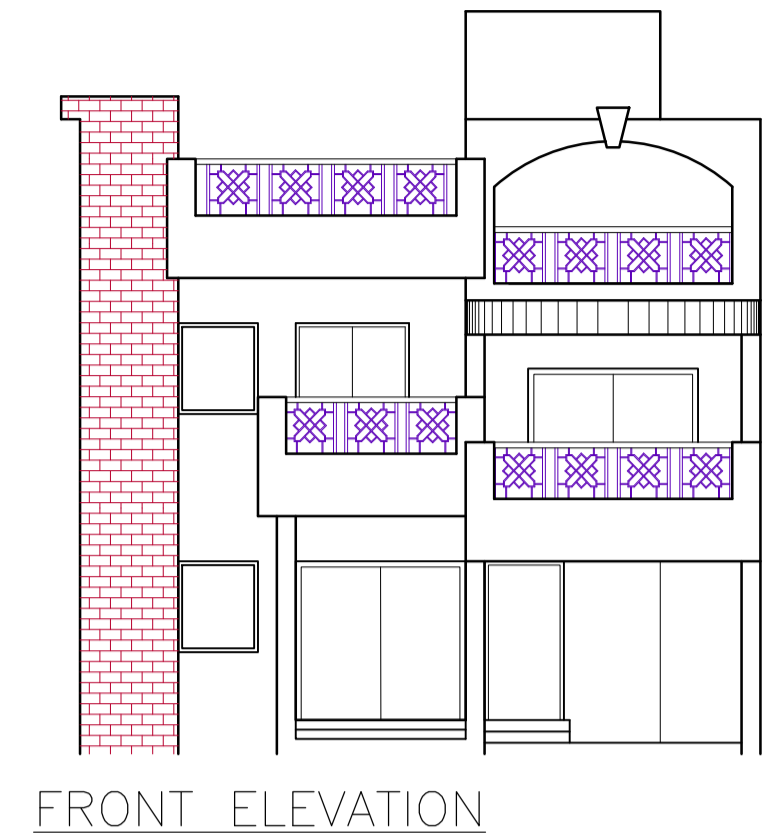
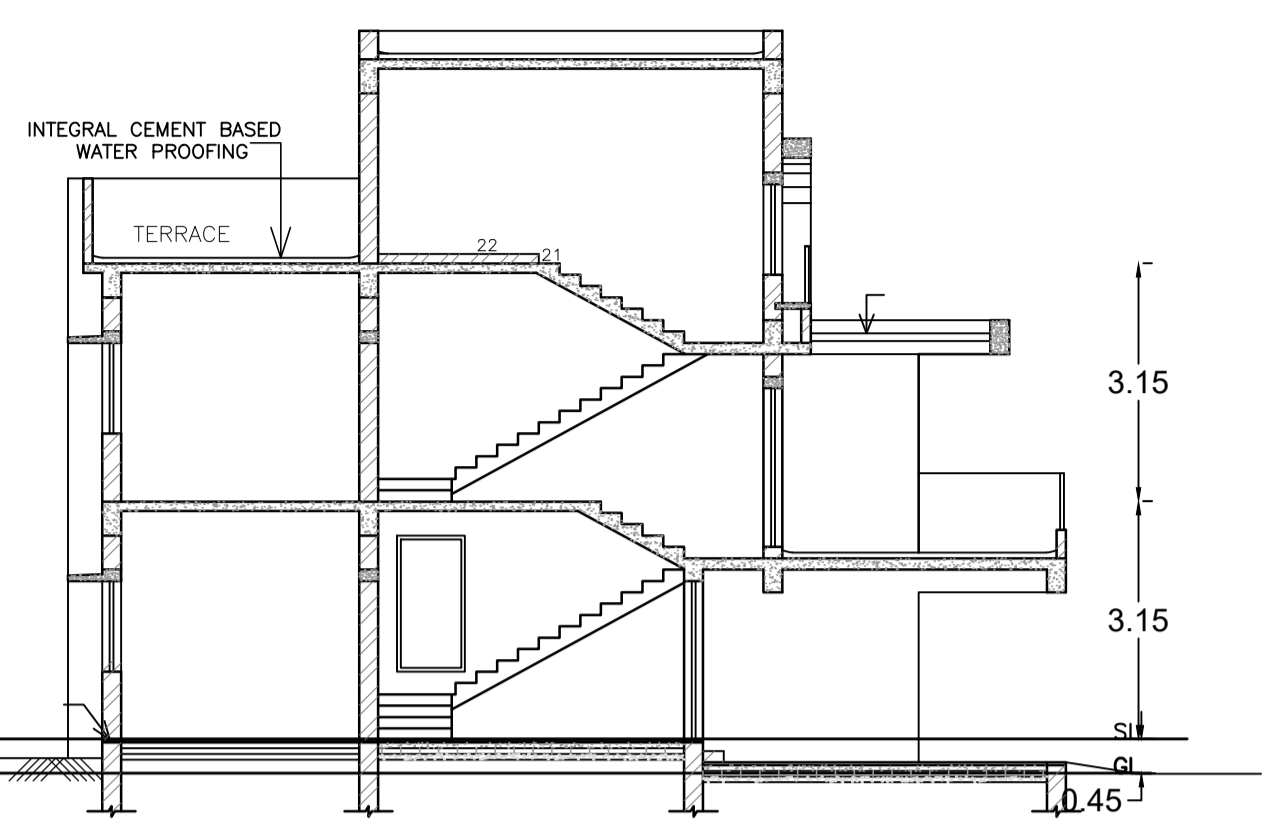
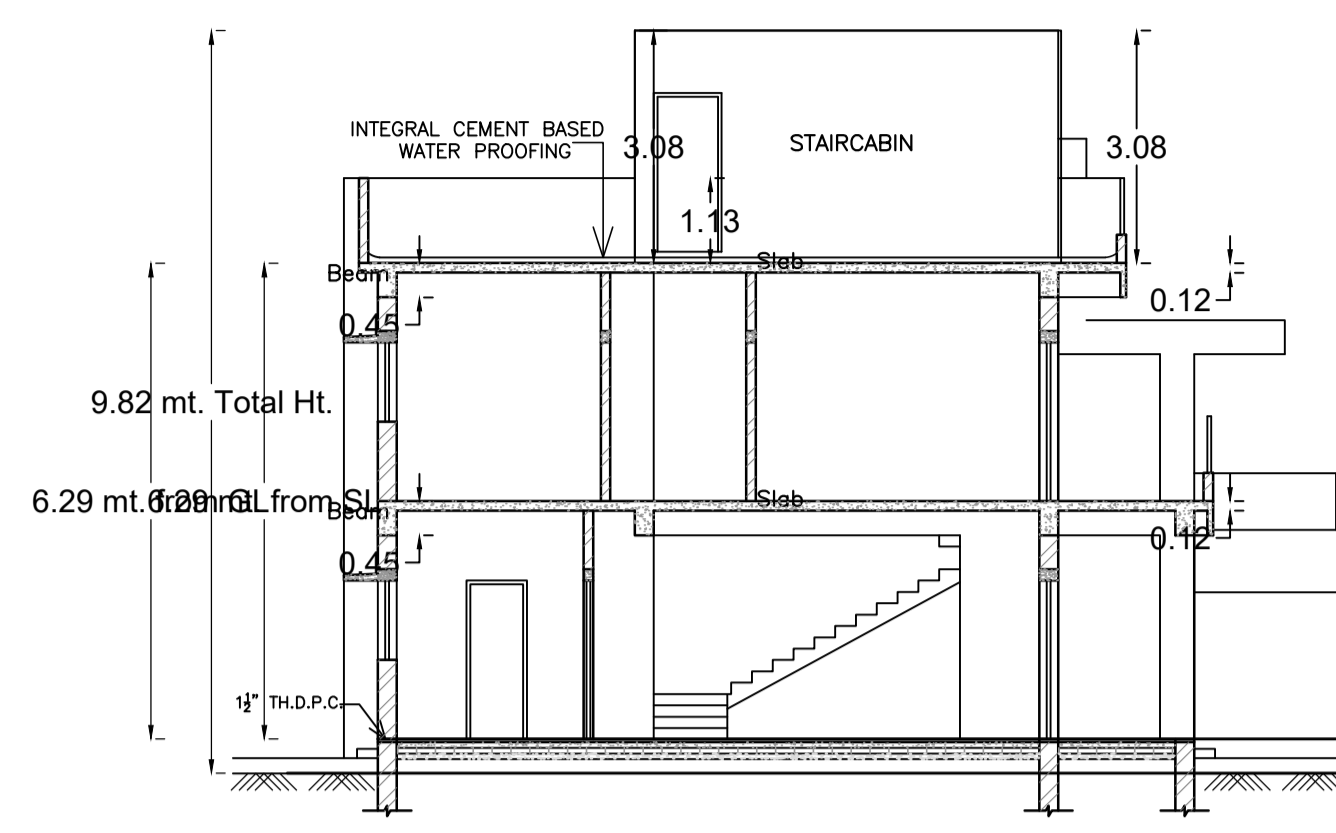
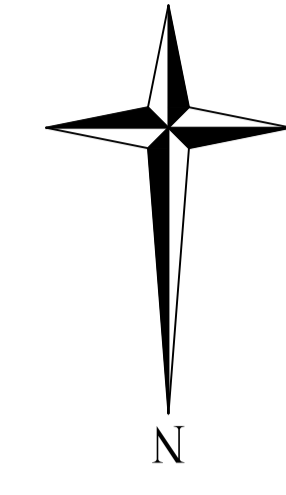
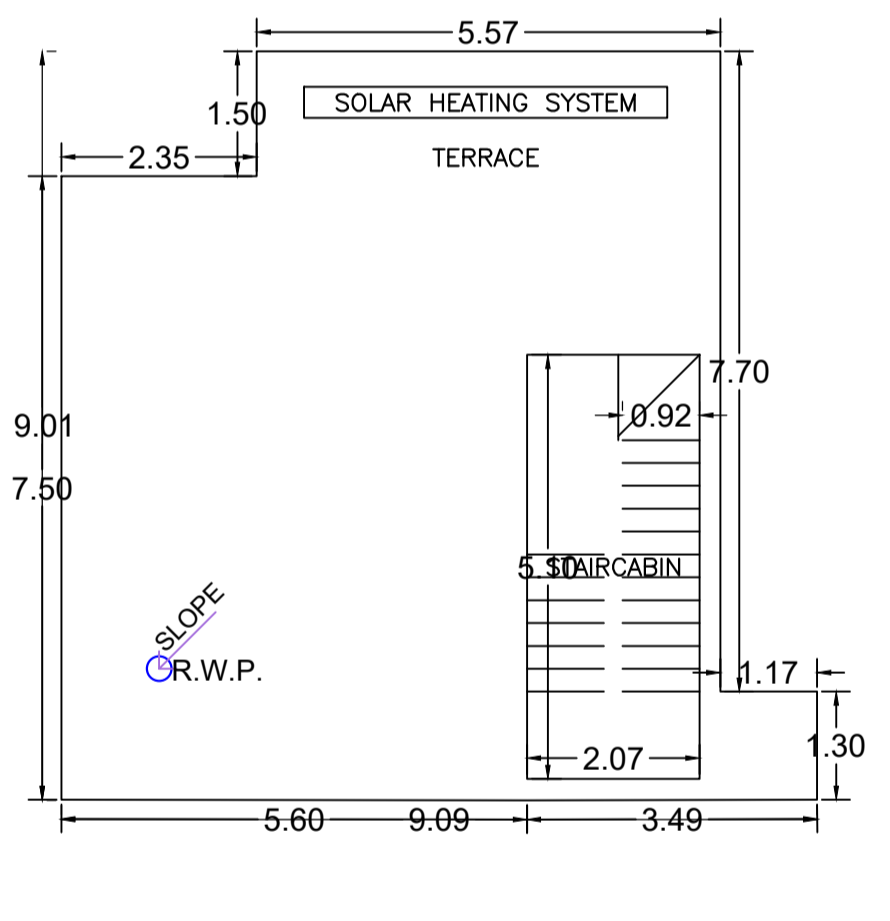
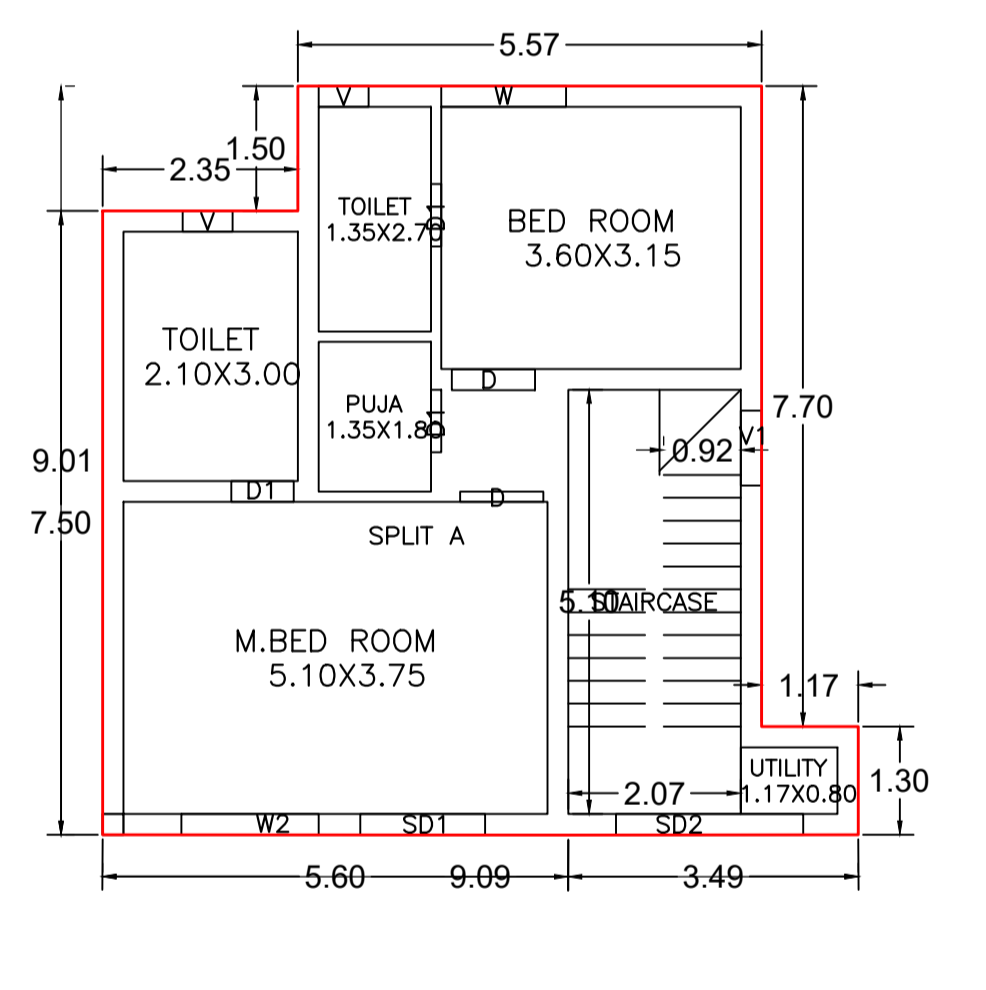
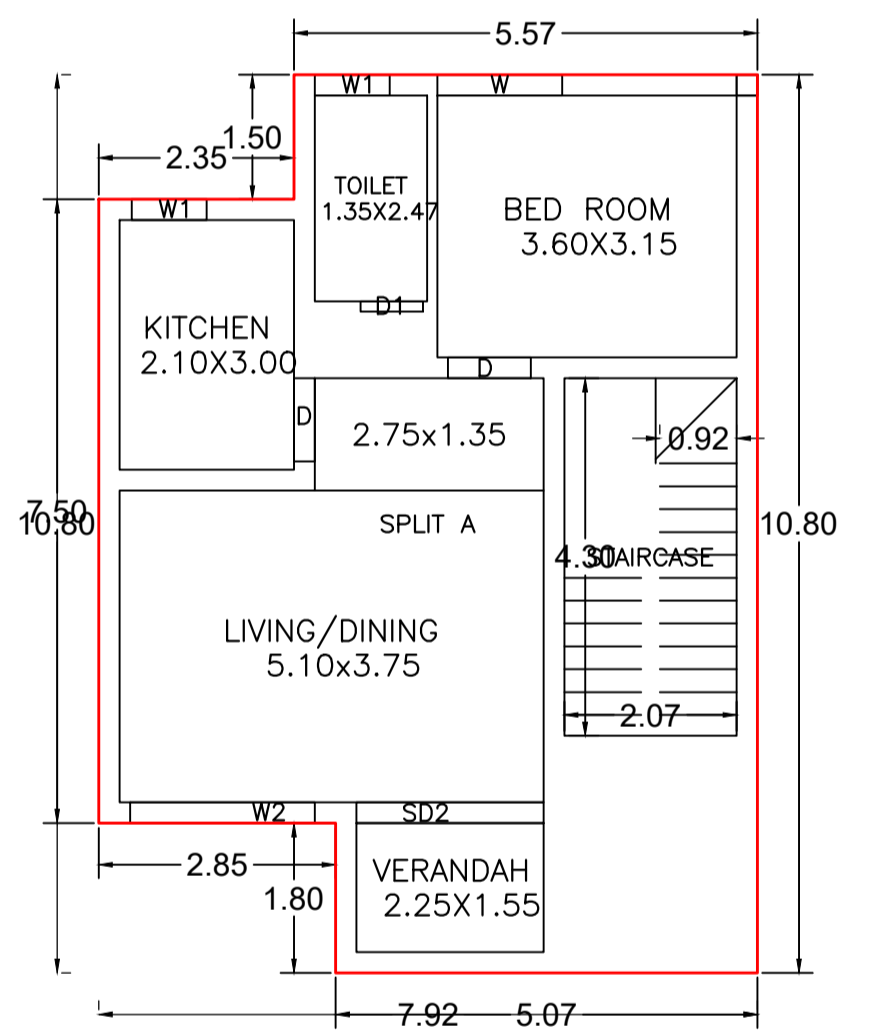
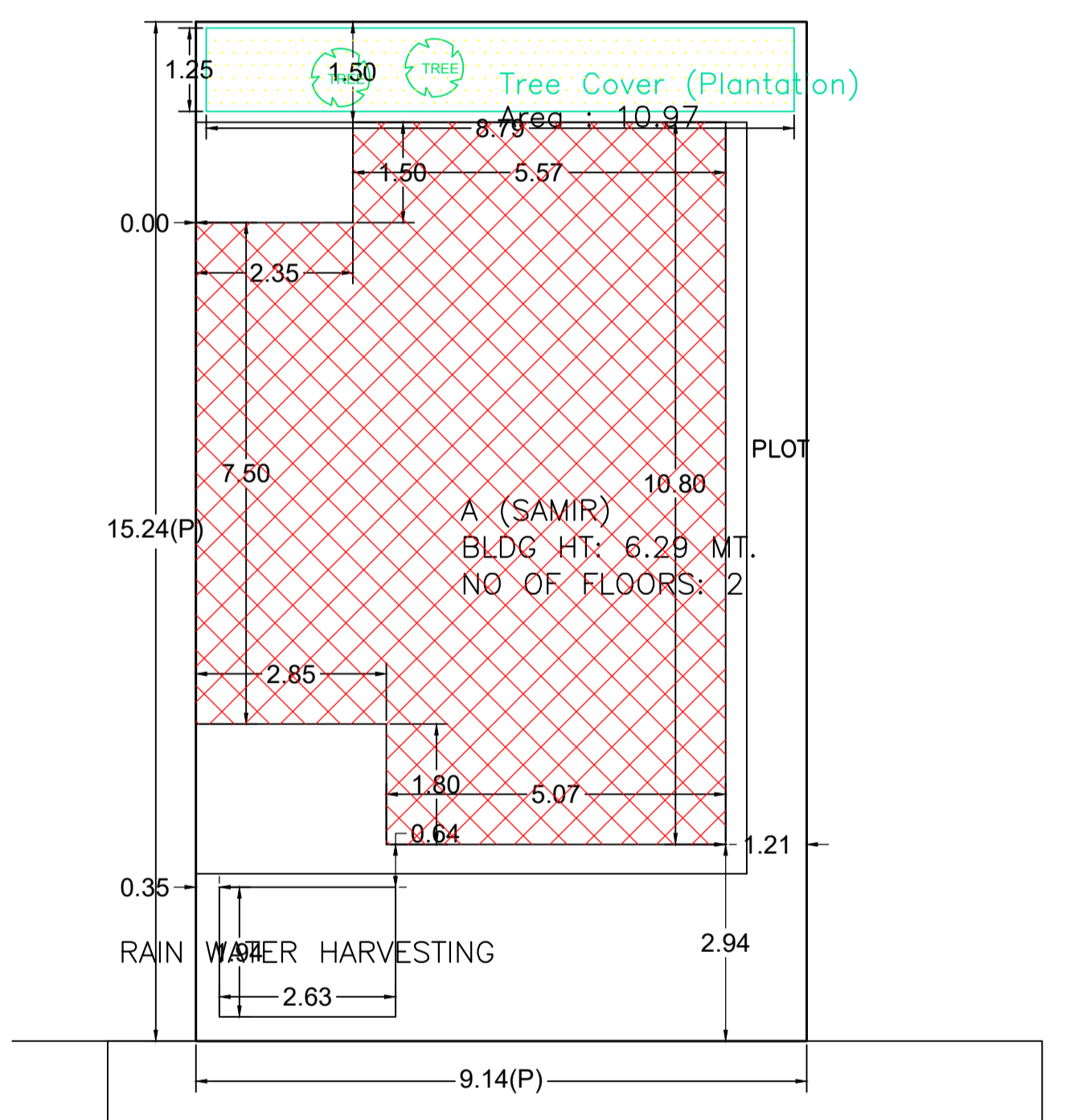
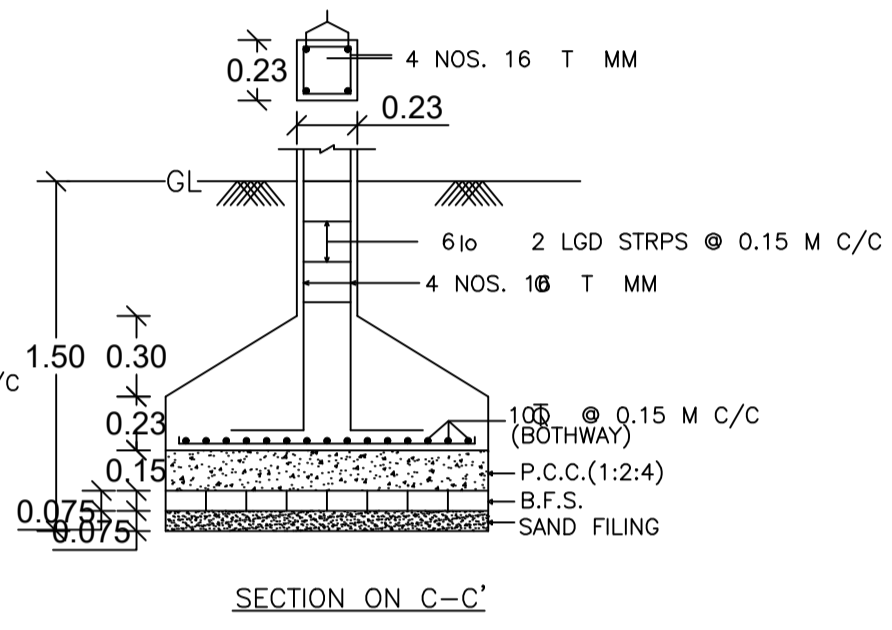
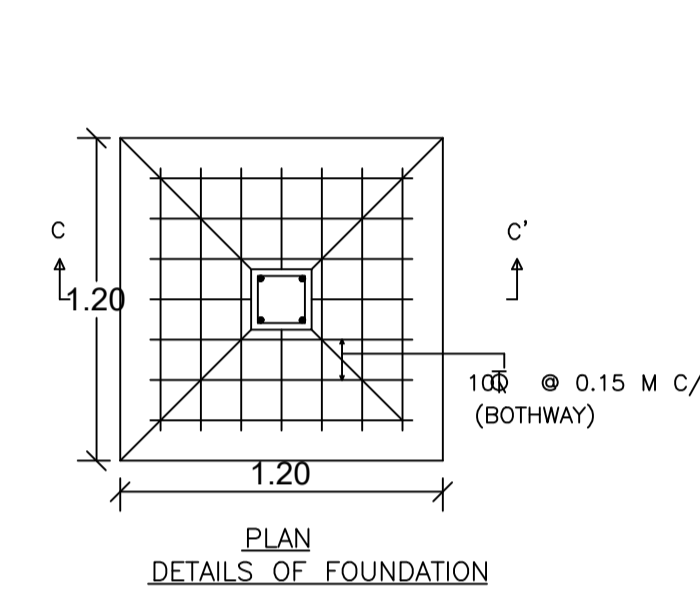
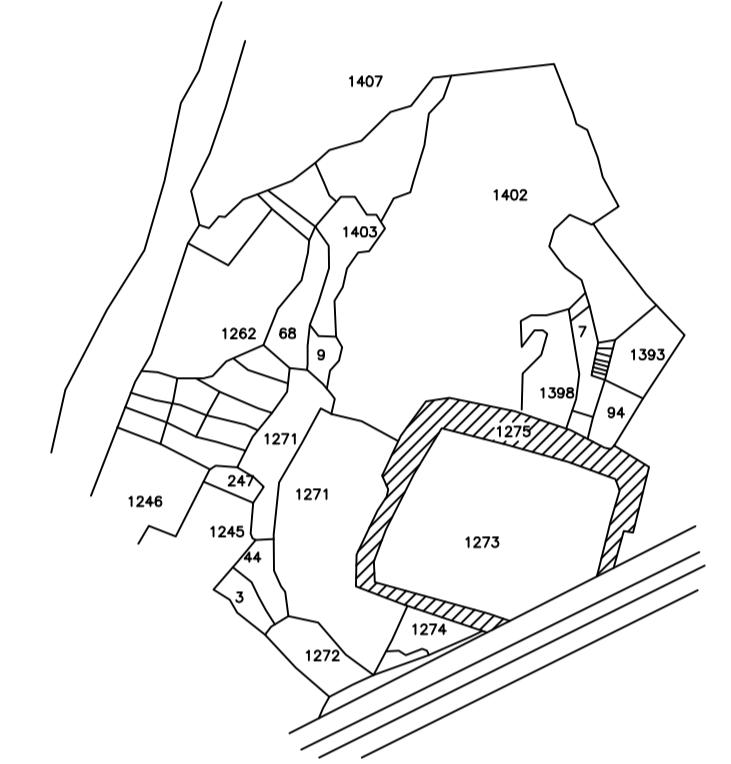

COLOR INDEX	
PLOT BOUNDARY	Black
ABUTTING ROAD	Red
PROPOSED CONSTRUCTION	Green
COMMON PLOT	Yellow
ROAD WIDENING AREA	Blue
EXISTING (To be retained)	Light Blue
EXISTING (To be demolished)	Orange

Floor Name	Building Name A (SAMIR)		Total	
	Proposed Built Up Area (Sq.mt.)	Proposed FAR Area (Sq.mt.)	Total Proposed Built Up Area (Sq.mt.)	Total FAR Area (Sq.mt.)
Ground Floor	76.92	76.92	76.92	76.92
First Floor	69.33	69.33	69.33	69.33
Terrace Floor	0.00	0.00	0.00	0.00
Total :	146.25	146.25	146.25	146.25

Building USE/SUBUSE Details									
Building Name	Building Use	Building SubUse	Building Structure	Floor Name	Floor Use	Floor SubUse	FAR Name	FAR Use	FAR SubUse
A (SAMIR)	Residential	Bungalow/ Dwelling / Non Apartment	Non-Highrise	GROUND FLOOR PLAN	Residential	Bungalow/ Dwelling / Non Apartment	Residential FAR	Residential	Bungalow/ Dwelling / Non Apartment
				FIRST FLOOR PLAN	Residential	Bungalow/ Dwelling / Non Apartment	Residential FAR	Residential	Bungalow/ Dwelling / Non Apartment
				TERRACE FLOOR PLAN	Residential	Bungalow/ Dwelling / Non Apartment	-	-	-

FAR & Tenement Details (Table 4c-1)						
Building	No. of Same Bldg	Total Built Up Area (Sq.mt.)	Proposed FAR Area (Sq.mt.)	Total FAR Area (Sq.mt.)	Total Consumed Additional FAR Area (Sq.mt.)	Tnmt (No.)
A (SAMIR)	1	146.25	146.25	146.25	146.25	01
Grand Total :	1	146.25	146.25	146.25	146.25	01

SCHEDULE OF DOOR:

BUILDING NAME	NAME	LENGTH	HEIGHT	NOS
A (SAMIR)	D1	0.75	2.10	04
A (SAMIR)	D	1.00	2.10	04
A (SAMIR)	SD1	1.50	2.10	01
A (SAMIR)	SD2	2.25	2.10	02

SCHEDULE OF WINDOW/VENTILATION:

BUILDING NAME	NAME	LENGTH	HEIGHT	NOS
A (SAMIR)	V	0.60	0.60	02
A (SAMIR)	V1	0.90	0.60	01
A (SAMIR)	W1	0.90	1.20	02
A (SAMIR)	W	1.50	1.20	02
A (SAMIR)	W2	1.65	1.20	01
A (SAMIR)	W2	2.22	1.20	01

Building :A (SAMIR)

Floor Name	Total Built Up Area (Sq.mt.)	Proposed FAR Area (Sq.mt.)	Total FAR Area (Sq.mt.)	Total Consumed Additional FAR Area (Sq.mt.)	Tnmt (No.)
Ground Floor	76.92	76.92	76.92	76.92	01
First Floor	69.33	69.33	69.33	69.33	00
Terrace Floor	0.00	0.00	0.00	0.00	00
Total :	146.25	146.25	146.25	146.25	01

UnitBUA Table for Building :A (SAMIR)

FLOOR	Name	UnitBUA Type	UnitBUA Area	Carpet Area	No. of Rooms	No. of Tenement
GROUND FLOOR PLAN	SPLIT A	FLAT	146.25	146.12	5	1
FIRST FLOOR PLAN	SPLIT A	FLAT	0.00	0.00	6	0
Total:	-	-	146.25	146.12	11	1

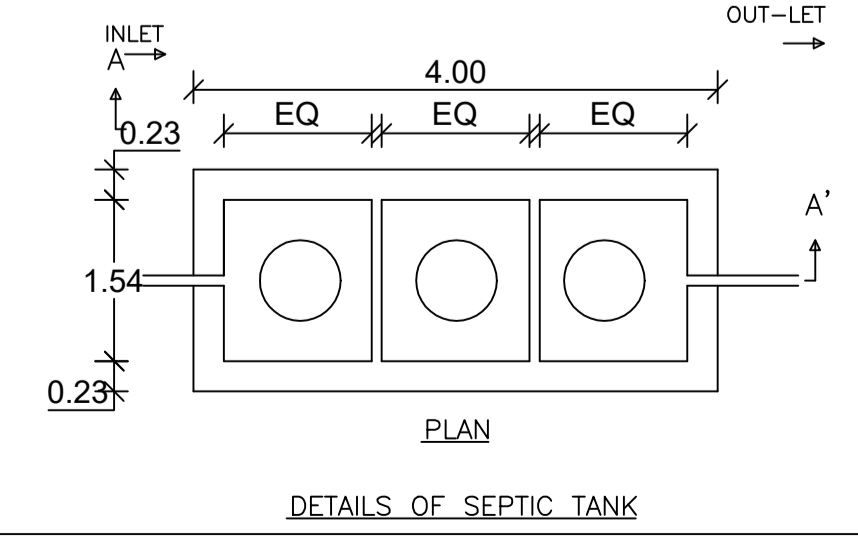
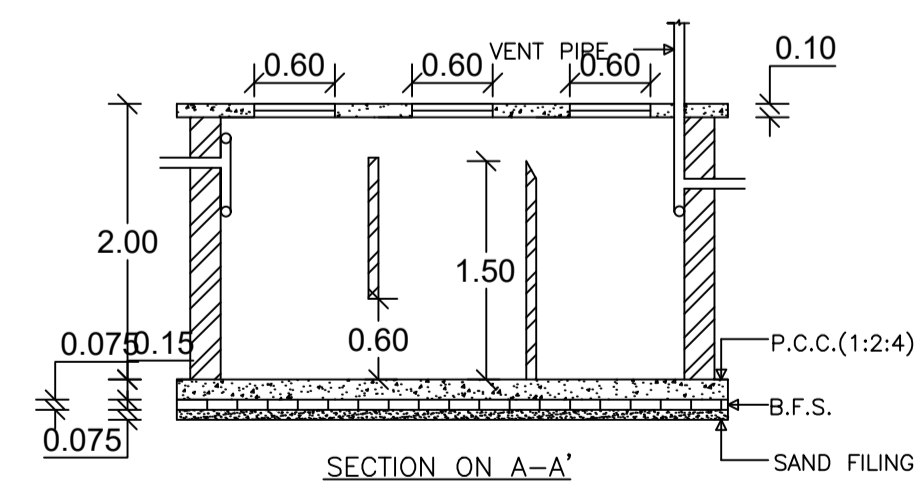
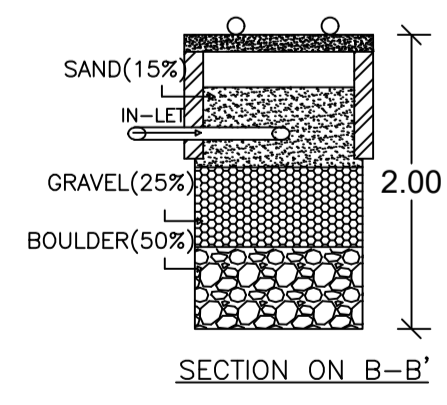
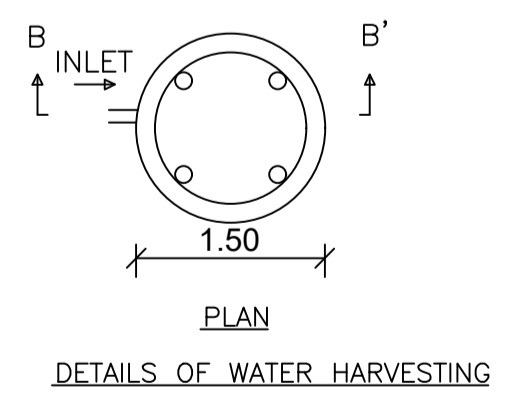

LTP NAME AND SIGNATURE	STRUCTURAL ENG'S NAME AND SIGNATURE	BUILDER NAME AND SIGNATURE	DIGITAL SIGNATURE
MOHAMMED AZIZULLAH CMC/ARC/0006/2018			