

Proposal Basic Information

Proposal File No.	CMC/BP/0079/W31/2024
Owner Name	JAI PRAKASH SINGH
Khata No	48
Plot No	25,26
Village Name	Kamaldih
Use	Residential
SubUse	ResiComm Bldg

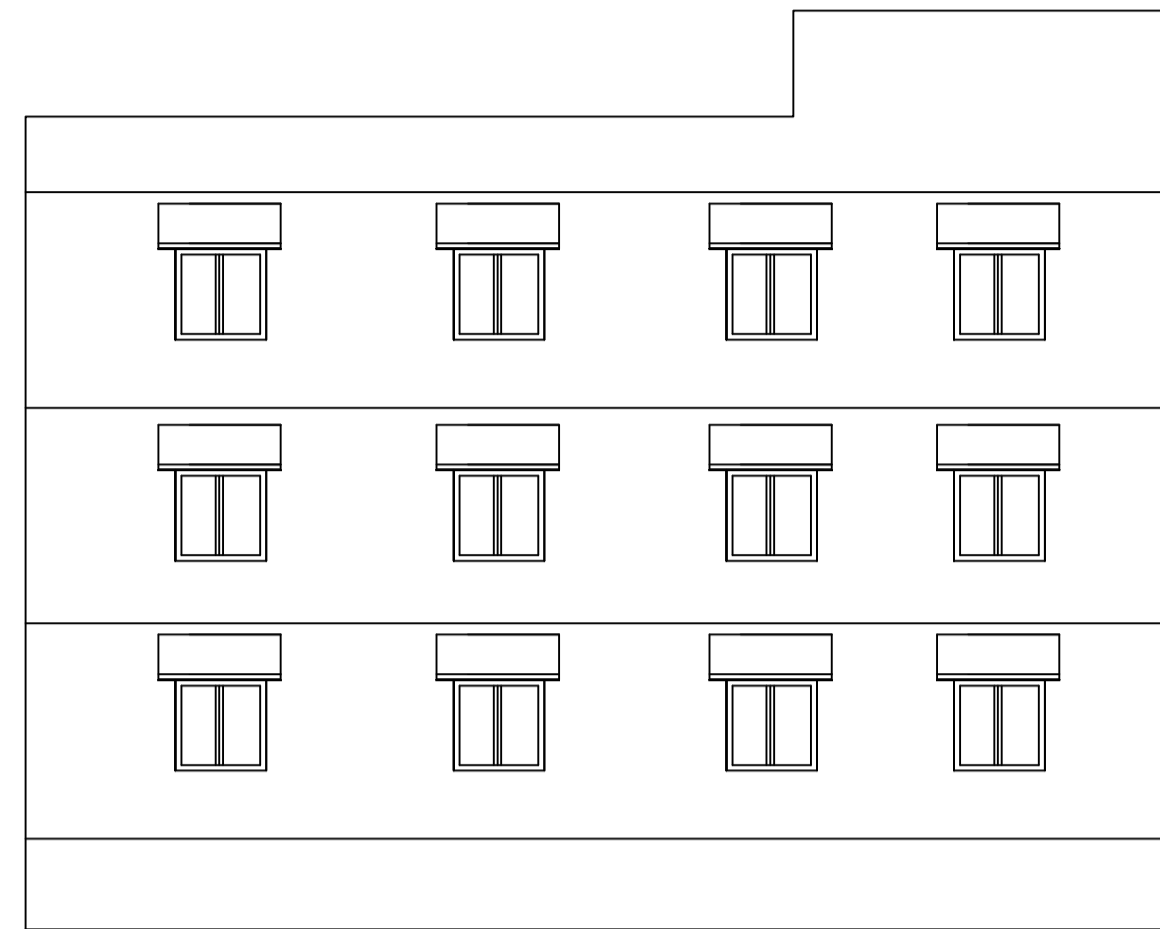

RIGHT SIDE ELEVATION

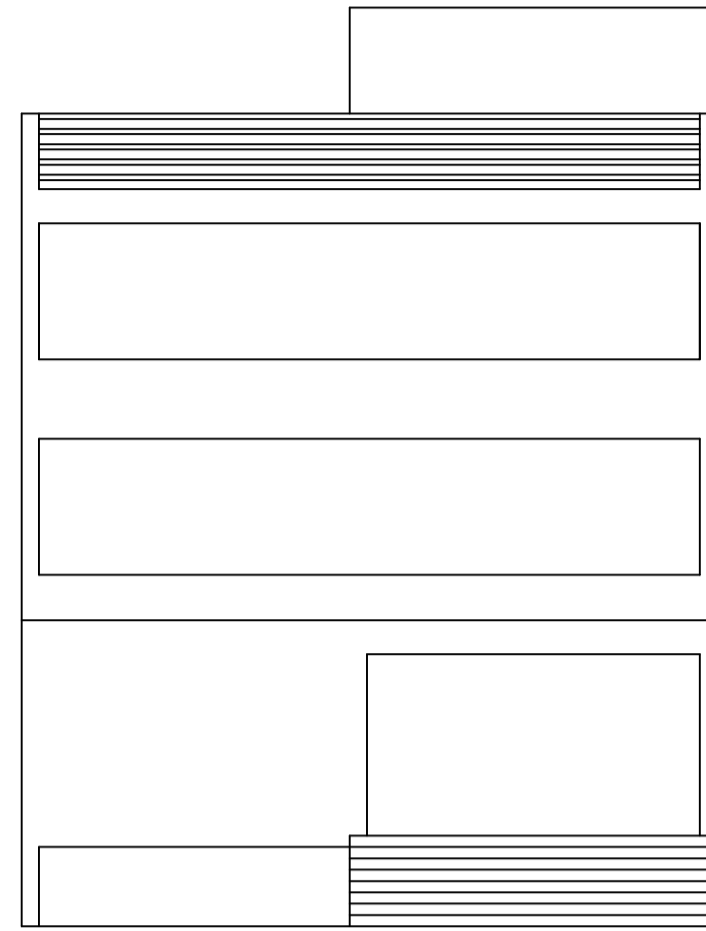

FRONT ELEVATION

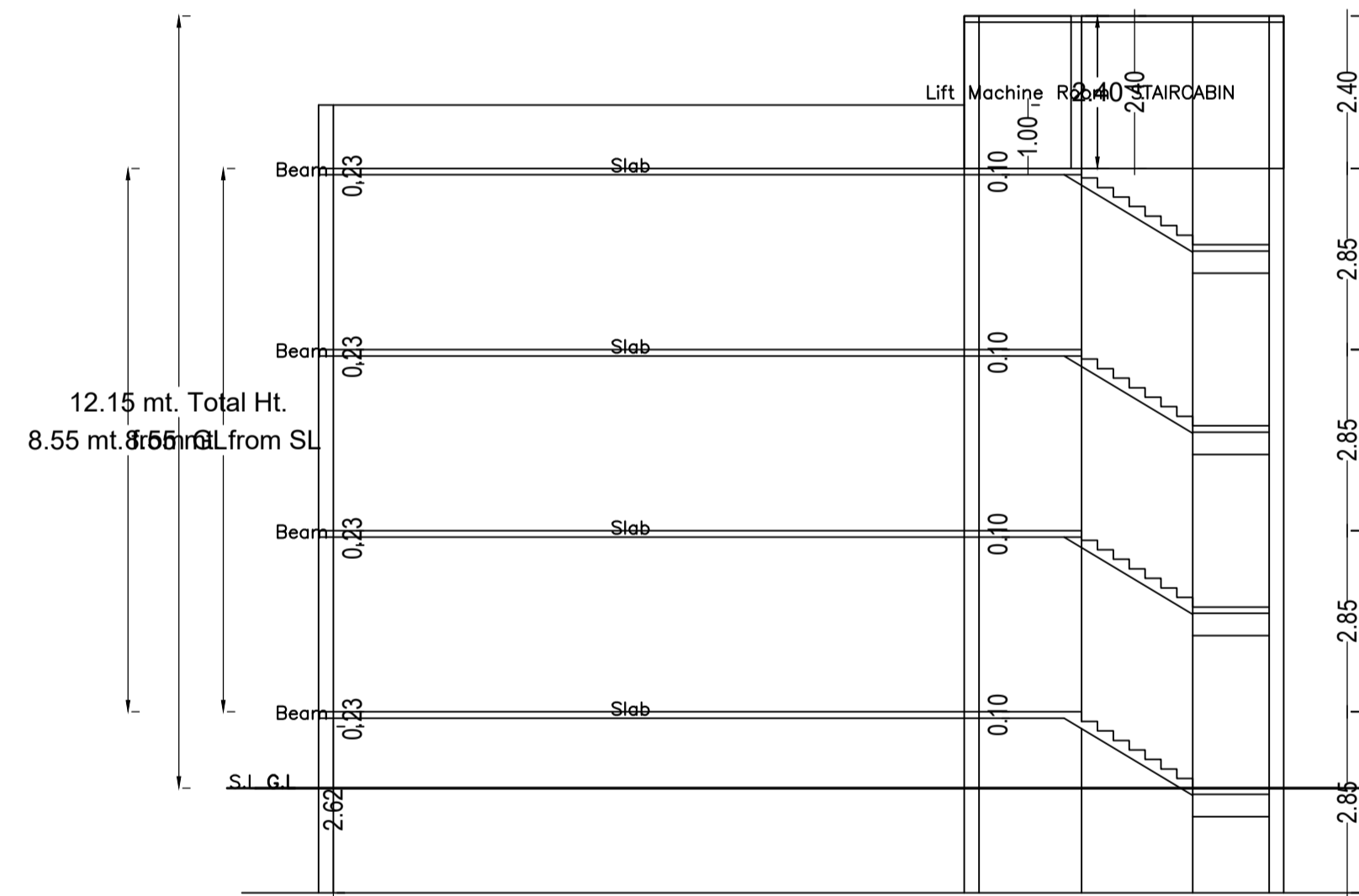
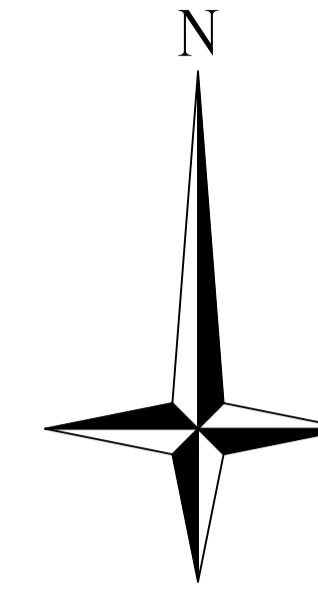

SECTION ON X-X

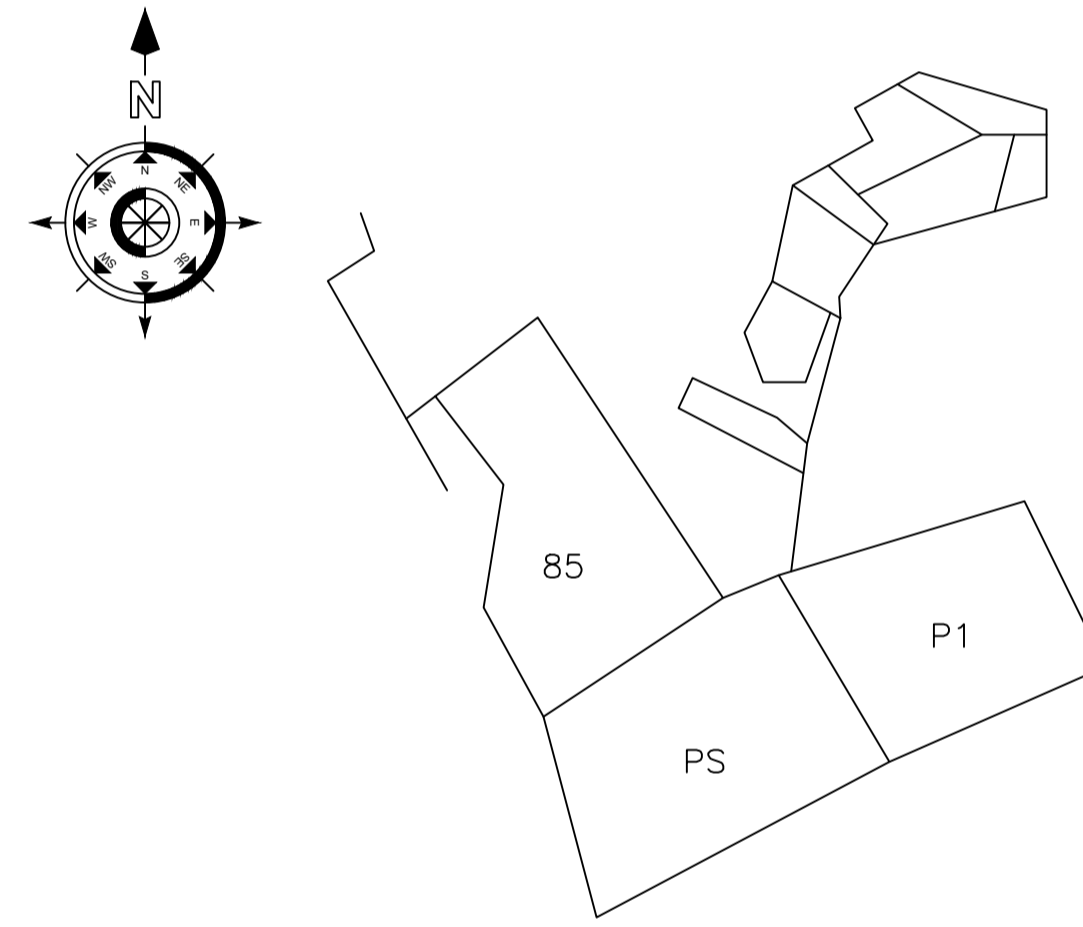

KEY PLAN

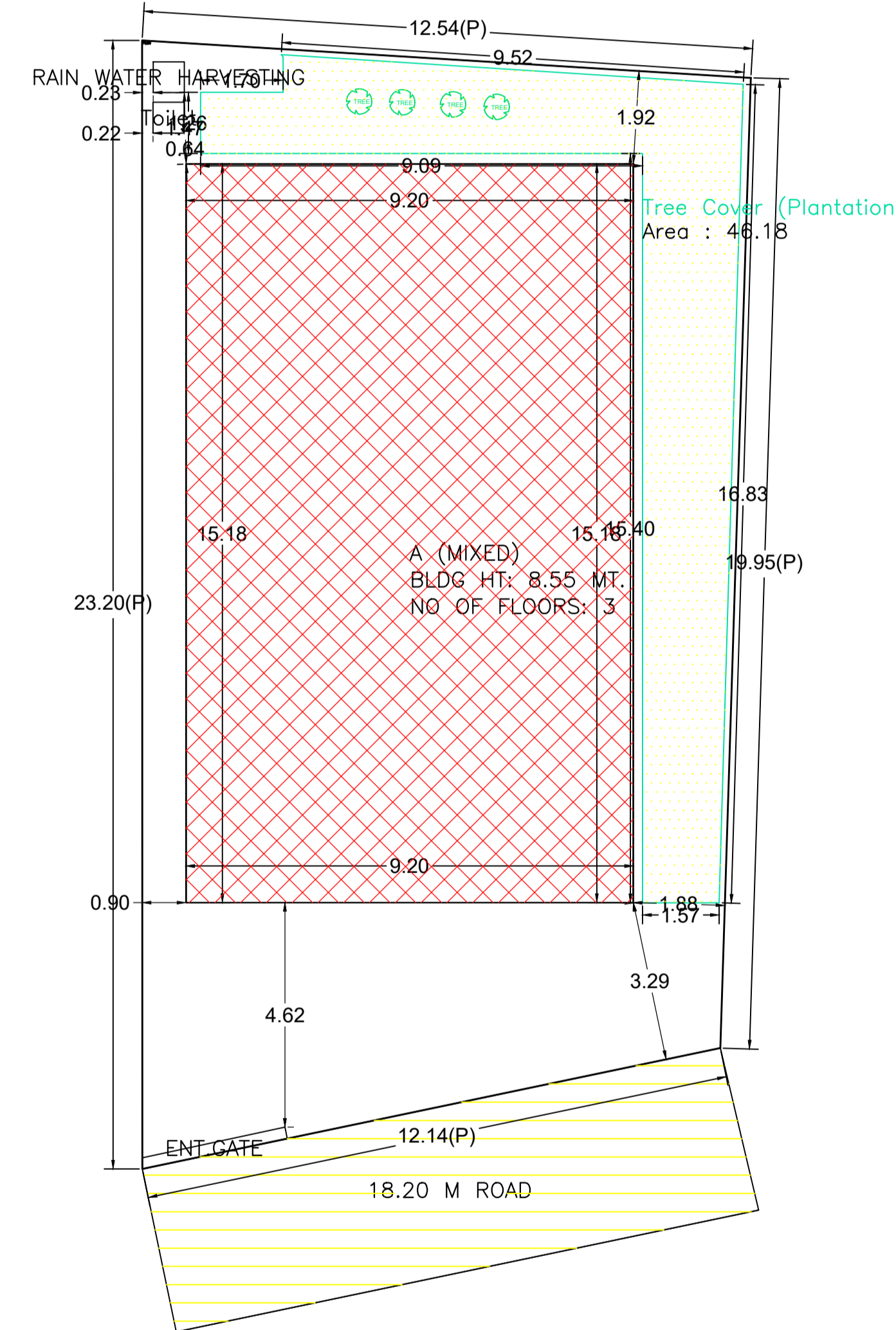

BASEMENT FLOOR PLAN

AREA STATEMENT CHAS MUNICIPAL CORPORATION	VERSION NO : 1.0.70	VERSION DATE: 16/10/2020
PROJECT DETAIL:		
Region: JHARKHAND URBAN LOCAL BODIES	Plot Use: Residential	
District: BOKARO	Plot SubUse: ResiComm Bldg	
Authority: CHAS MUNICIPAL CORPORATION	PlotNearbyReligiousStructure: NA	
Inward_No: CMC/BP/0079/W31/2024	Plot/SubPlot No: 25,26	
Application Type: General Proposal	North: Road Width - ROAD	
Project Type: Building Permission	South: Plot No. - 20	
Nature of Development: New	East: Plot No. - 27,28	
Location of Development Area: Old Area	West: Road Width - 28	
AREA DETAILS:		
AREA OF PLOT (Minimum)	(A)	SQ.MT. 262.95
NET AREA OF PLOT(Gross Plot Area - Deduction from Gross Plot area)	(A-Deductions)	262.95
Deduction for Balance Plot Area(from Gross Plot Area)		
Common Plot		46.18
Total		46.18
BALANCE AREA OF PLOT(Net Plot Area - Recreational/Amenity space)	(A-Deductions)	216.78
PLOT AREA FOR COVERAGE(Net Plot Area)	(A-Deductions)	262.95
Plot Area for FAR (Net Plot Area + RoadWidening Area)	(A-Deductions)	262.95
COVERAGE CHECK		
Permissible Coverage area (60.00 %)		157.77
Proposed Coverage Area (53.13 %)		139.70
Total Prop. Coverage Area (53.13 %)		139.70
Balance coverage area (6.87 %)		18.07
FAR CHECK		
Perm. FAR Area (2.500)		657.38
Total Perm. FAR area		657.38
Residential FAR		259.35
Commercial FAR		133.10
Proposed FAR Area		402.21
Total Proposed FAR Area		402.21
Consumed FAR (Factor)		1.53
Balance FAR Area		255.17
BUILT UP AREA CHECK		
Total Proposed BuiltUp Area		558.57
ARCHITECT (Regd)	PUJA KUMARI	
ENGINEER (Regd)		
SUPERVISOR (Regd)		
OWNER (Regd)	JAI PRAKASH SINGH	
DEVELOPMENT AUTHORITY		LOCAL BODY

Floor Name	Total Built Up Area (Sq.mt.)	Deductions (Area in Sq.mt.)			Proposed FAR Area (Sq.mt.)		Add Area In FAR (Sq.mt.)	Total FAR Area (Sq.mt.)	Total Consumed FAR Area (Sq.mt.)	Trmt (No.)
		Lift	Accessory Use	Parking	Resi.	Commercial				
Basement Floor	139.63	3.35	0.00	111.13	0.00	0.00	9.76	9.76	9.76	00
Ground Floor	139.70	0.00	6.60	0.00	0.00	133.10	0.00	133.10	133.10	01
First Floor	139.62	3.35	6.60	0.00	129.67	0.00	0.00	129.67	129.67	01
Second Floor	139.62	3.35	6.60	0.00	129.67	0.00	0.00	129.67	129.67	00
Terrace Floor	0.00	0.00	0.00	0.00	0.00	0.00	0.00	0.00	0.00	00
Total	558.57	10.05	19.80	111.13	259.34	133.10	9.76	402.20	402.20	02
Total Number of Same Buildings	1									
Total	558.57	10.05	19.80	111.13	259.34	133.10	9.76	402.20	402.20	02

BUILDING NAME	NAME	LENGTH	HEIGHT	NOS
A (MIXED)	D	0.75	2.10	06
A (MIXED)	RS	2.75	2.10	02
A (MIXED)	D	3.00	2.10	02

BUILDING NAME	NAME	LENGTH	HEIGHT	NOS
A (MIXED)	V	0.60	1.20	06

FLOOR	Name	UnitBUA Type	UnitBUA Area	Carpet Area	No. of Rooms	No. of Tenement
GROUND FLOOR PLAN	HALL	SHOP	106.42	106.40	4	1
FIRST FLOOR PLAN	SPLIT 1	FLAT	272.55	272.49	4	1
SECOND FLOOR PLAN	SPLIT 1	FLAT	0.00	0.00	4	0
Total	-	-	378.97	378.89	12	2

Required Parking(Table 7a)

Building Name	Type	SubUse	Area (Sq.mt.)		Units		Car		Visitors Car		TwoWheeler	
			Reqd.	Prop.	Reqd.	Prop.	Reqd./Unit	Reqd.	Prop.	Reqd./Unit	Reqd.	Prop.
A (MIXED)	Commercial	Shop	>0	50	120.00	1	2	-	-	-	-	-
			>0	50	120.00	-	-	-	-	-	1	6
	Residential	ResiComm Bldg	>0	1	1.00	1	1	-	-	-	-	-
			>0	1	1.00	-	-	-	-	-	1	1
Total			-	-	-	3	3	-	1	1	-	

Parking Check (Table 7b)

Vehicle Type	Reqd.		Prop.	
	No.	Area	No.	Area
Total Car	3	37.50	3	37.50
Visitor's Car Parking	-	-	1	12.50
Total Visitor Parking	1	12.50	1	12.50
TwoWheeler	-	-	7	14.00
Total TwoWheeler	7	14.00	7	14.00
Other Parking	-	-	-	47.23
Total		64.00		125.23

FAR & Tenement Details (Table 4c-1)

Building	No. of Same Bldg	Total Built Up Area (Sq.mt.)	Deductions (Area in Sq.mt.)			Proposed FAR Area (Sq.mt.)	Add Area In FAR (Sq.mt.)	Total FAR Area (Sq.mt.)	Total Consumed Additional FAR Area (Sq.mt.)	Trmt (No.)	
			Lift	Accessory Use	Parking						
A (MIXED)	1	558.57	10.05	19.80	111.13	259.34	133.10	9.76	402.20	402.20	02
Grand Total	1	558.57	10.05	19.80	111.13	259.34	133.10	9.76	402.20	402.20	02

Building USE/SUBUSE Details

Building Name	Building Use	Building SubUse	Building Structure
A (MIXED)	Residential	ResiComm Bldg	Non-Highrise

Buildingwise Floor FAR Details

Floor Name	Building Name A (MIXED)		Total	
	Proposed Built Up Area (Sq.mt.)	Proposed FAR Area (Sq.mt.)	Total Proposed Built Up Area (Sq.mt.)	Total FAR Area (Sq.mt.)
Basement Floor	139.63	9.76	139.63	9.76
Ground Floor	139.70	133.10	139.70	133.10
First Floor	139.62	129.67	139.62	129.67
Second Floor	139.62	129.67	139.62	129.67
Terrace Floor	0.00	0.00	0.00	0.00
Total	558.57	402.20	558.57	402.20

COLOR INDEX

PLOT BOUNDARY	Black
ABUTTING ROAD	Green
PROPOSED CONSTRUCTION	Red
COMMON PLOT	Yellow
ROAD WIDENING AREA	Blue
EXISTING (To be retained)	Light Blue
EXISTING (To be demolished)	Dark Blue

LTP NAME AND SIGNATURE	STRUCTURAL ENG'S NAME AND SIGNATURE	BUILDER NAME AND SIGNATURE	DIGITAL SIGNATURE
PUJA KUMARI CMC/ENG/0005/2023			

Proposal Basic Information	
Proposal File No.	CMC/BP/0079/W31/2024
Owner Name	JAI PRAKASH SINGH
Khata No	48
Plot No	25,26
Village Name	Kamaldih
Use	Residential
SubUse	ResiComm Bldg

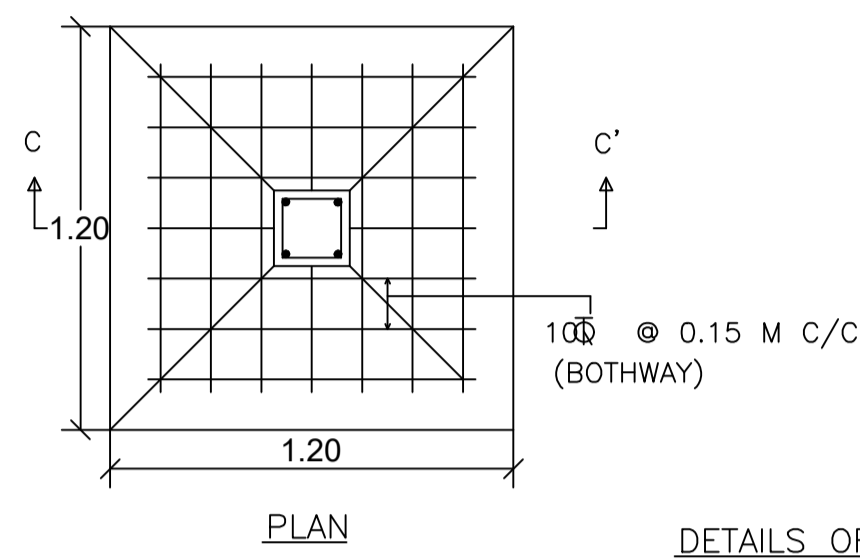
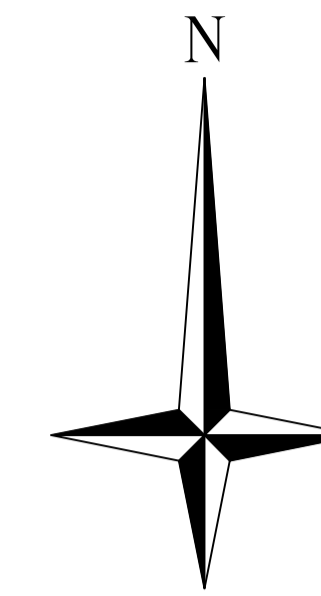

DETAILS OF FOUNDATION

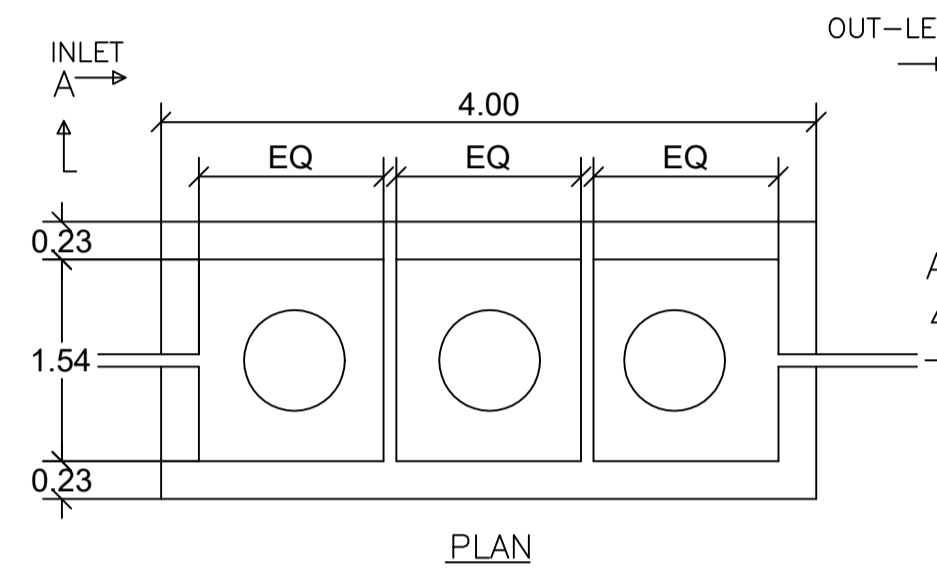
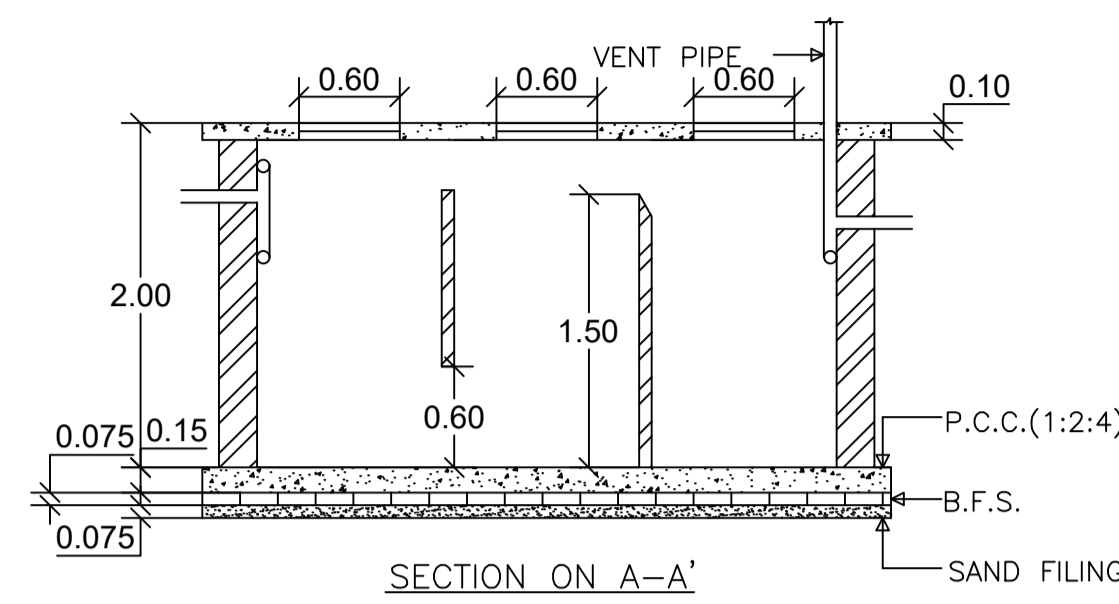
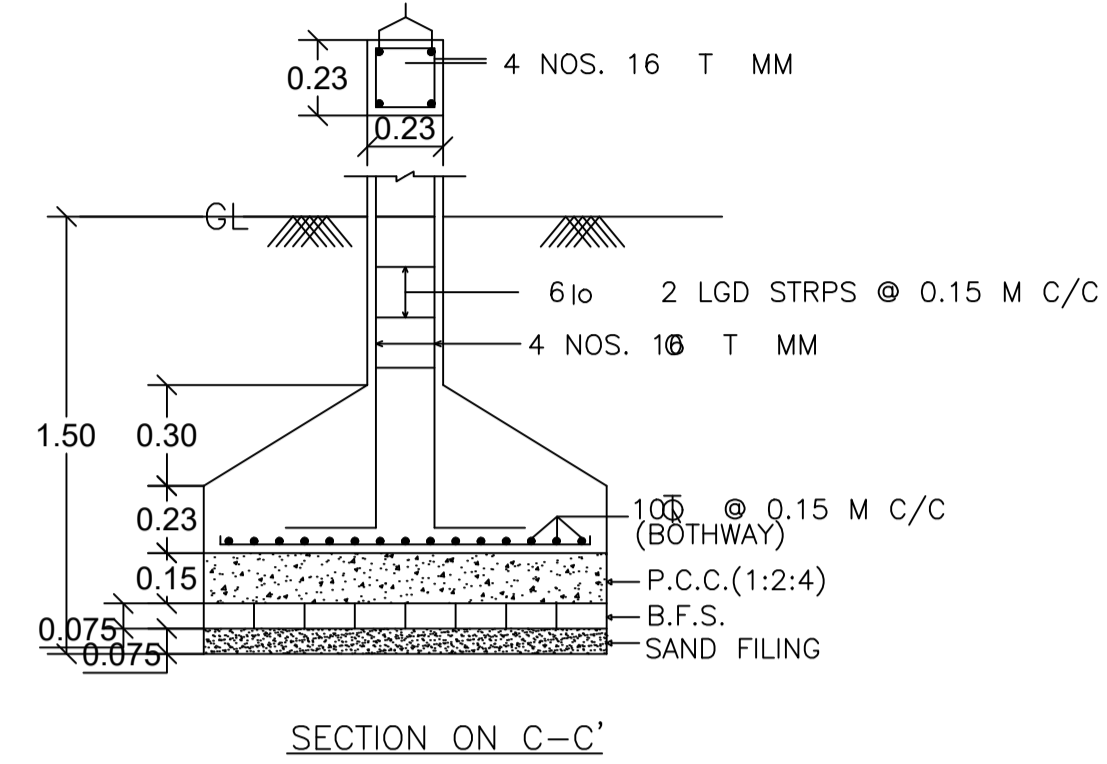

DETAILS OF SEPTIC TANK

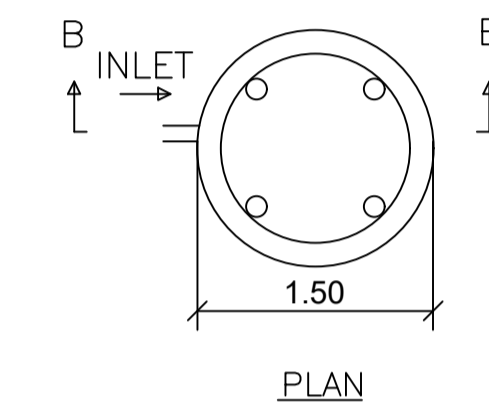

PLAN

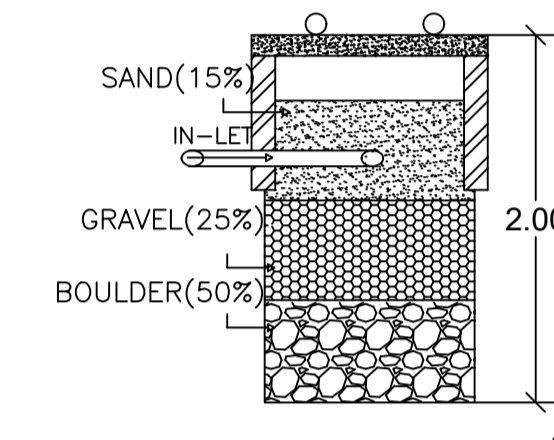

SECTION ON B-B'

DETAILS OF WATER HARVESTING

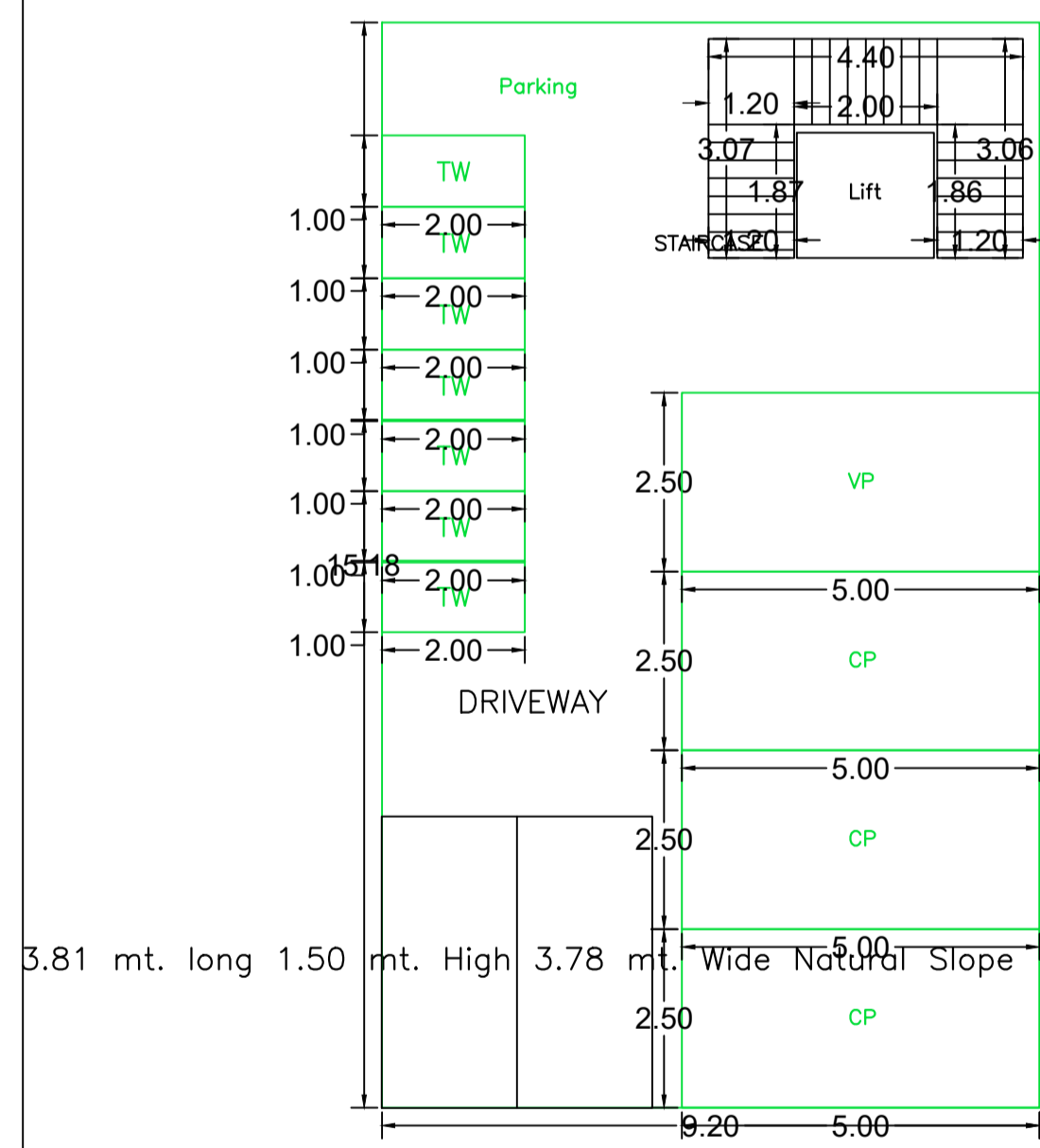

BASEMENT FLOOR PLAN (SCALE 1:100)

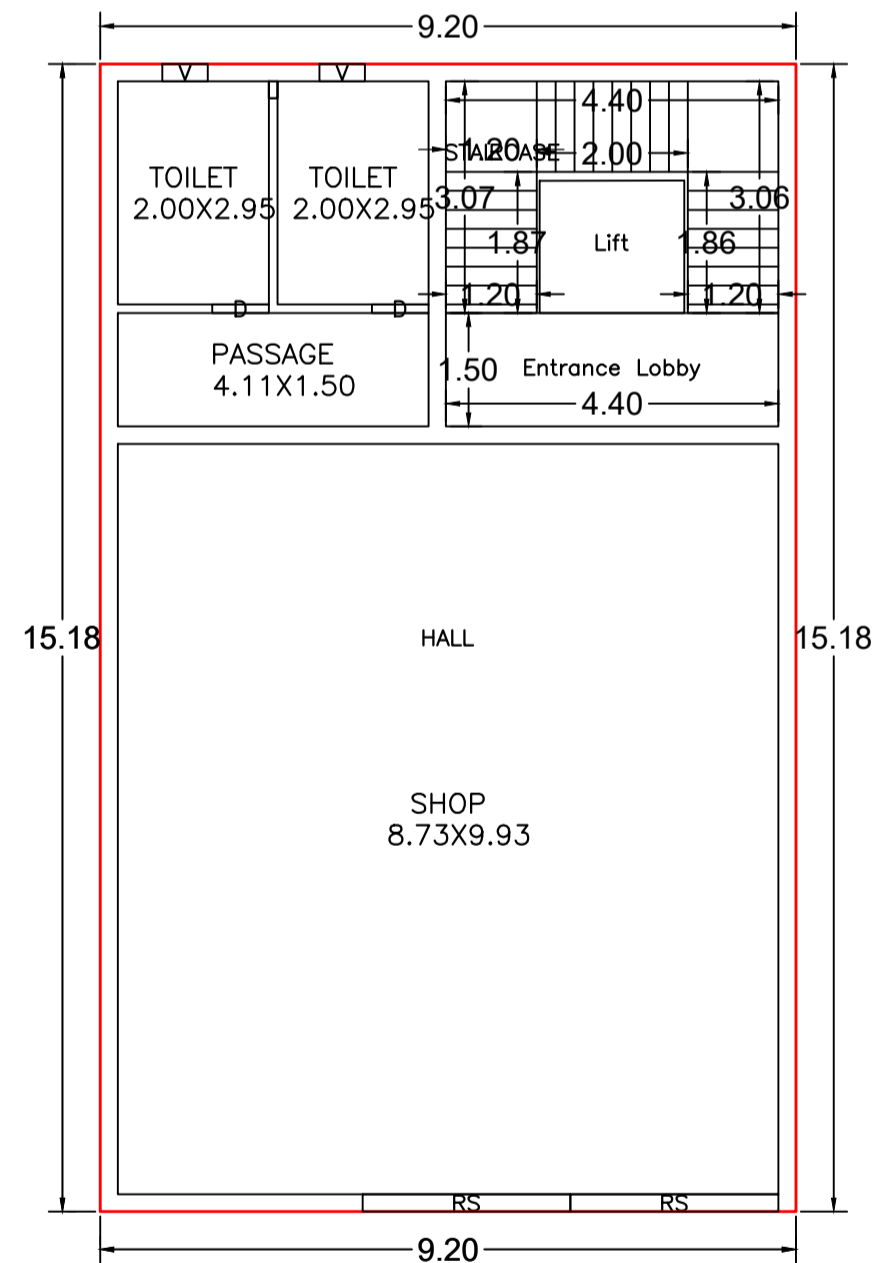

GROUND FLOOR PLAN (Proposed) (SCALE 1:100)

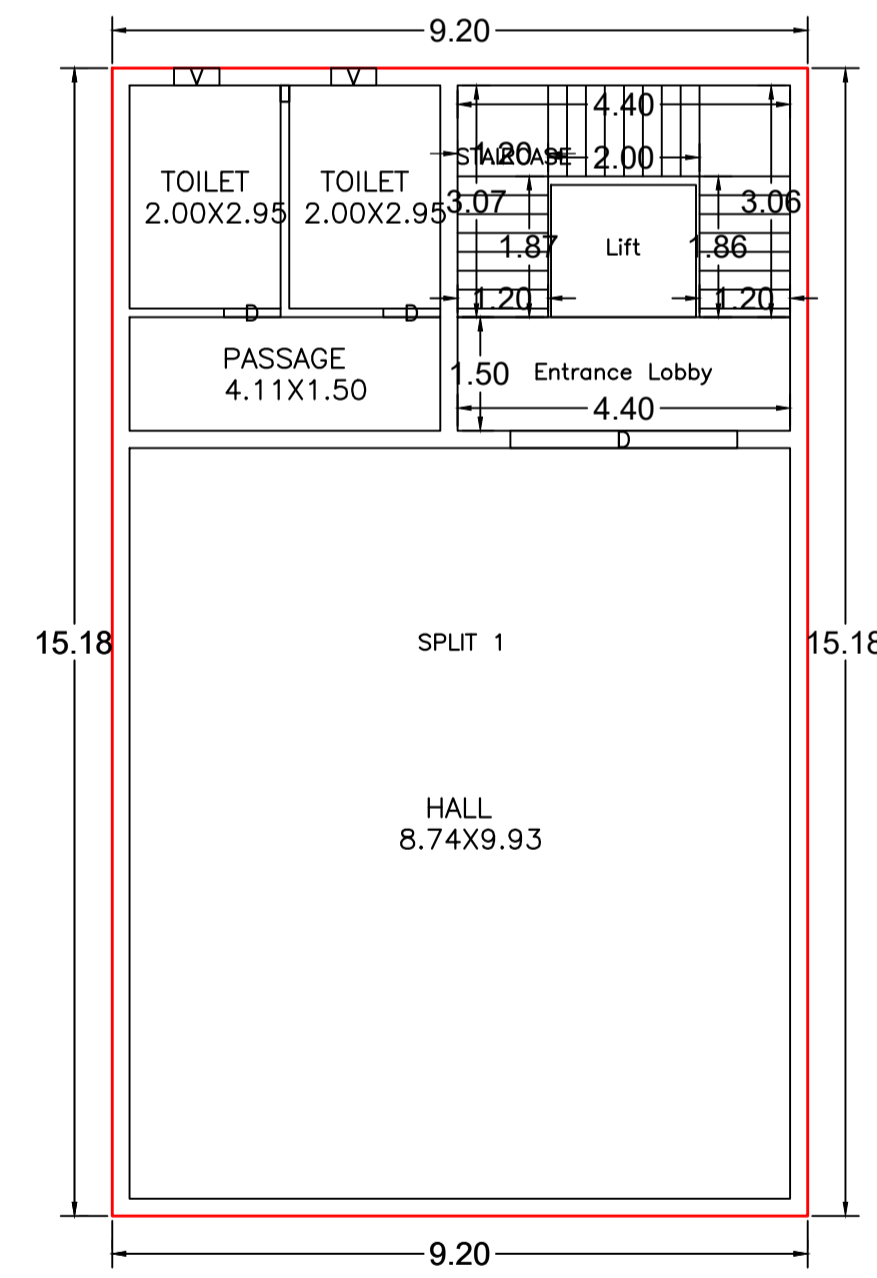

FIRST FLOOR PLAN (Proposed) (SCALE 1:100)

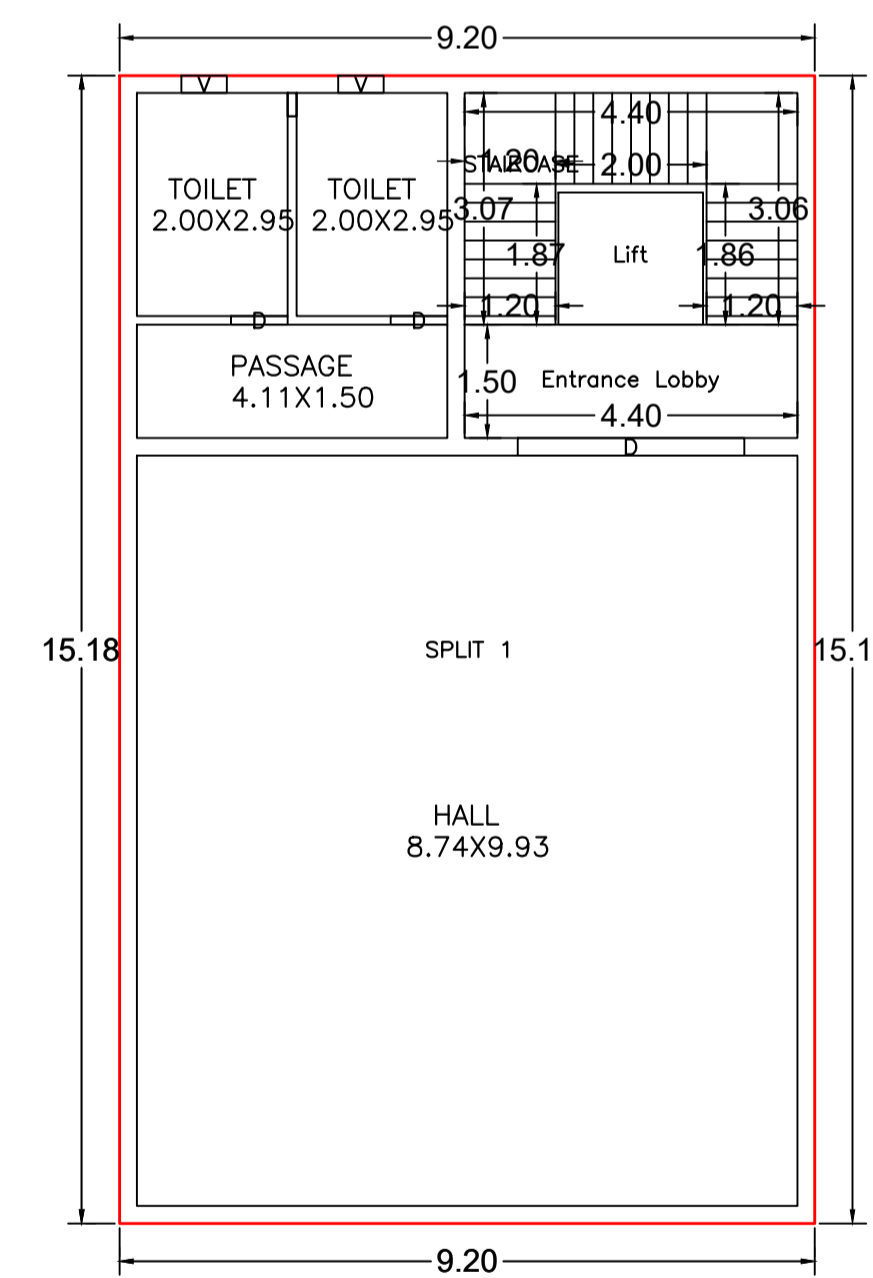

SECOND FLOOR PLAN (Proposed) (SCALE 1:100)

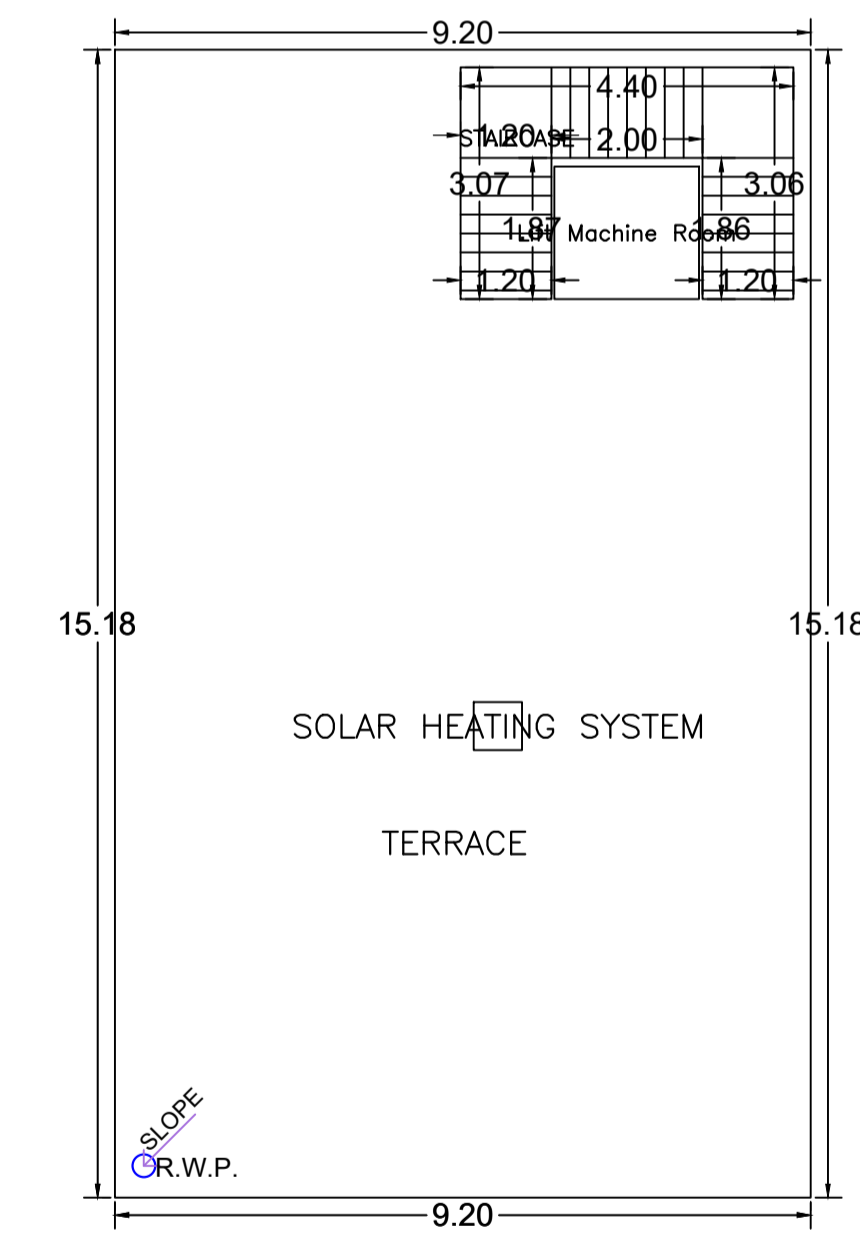

TERRACE FLOOR PLAN (SCALE 1:100)

LTP NAME AND SIGNATURE	STRUCTURAL ENG'S NAME AND SIGNATURE	BUILDER NAME AND SIGNATURE	DIGITAL SIGNATURE
PUJA KUMARI CMC/ENG/0005/2023			