

Proposal Basic Information

Proposal File No.	CMC/BP/0072/W30/2024
Owner Name	KIRAN DEVI
Khata No	28
Plot No	5, (Co-operative plot no 115)
Village Name	Bandhgora
Use	Residential
SubUse	Bungalow/ Dwelling / Non Apartment

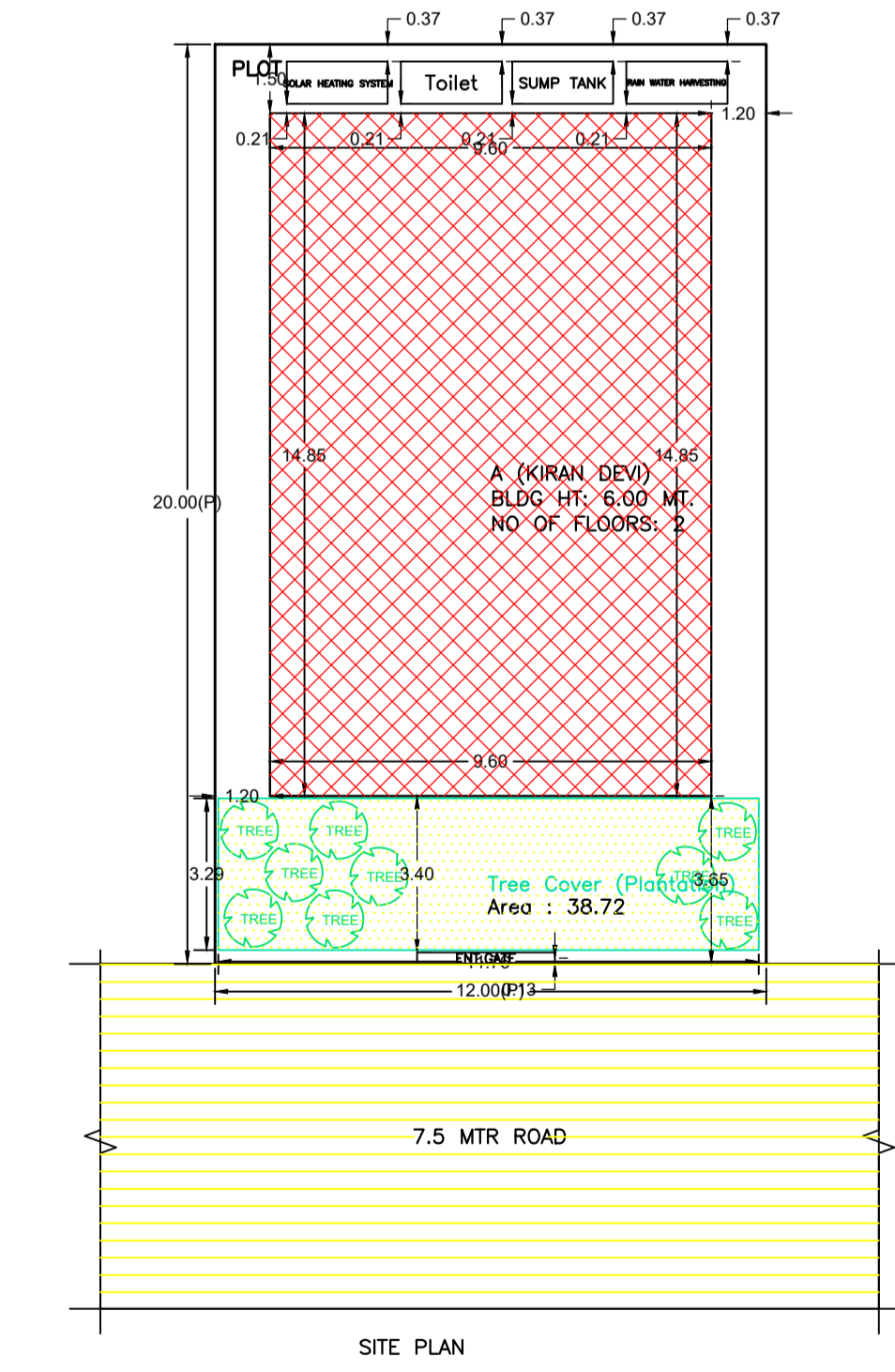
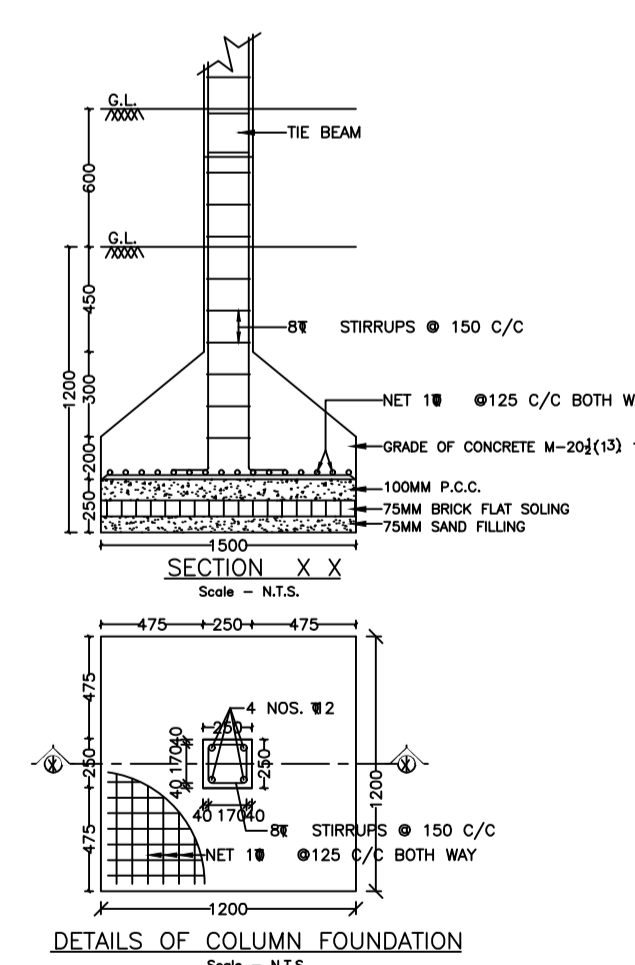
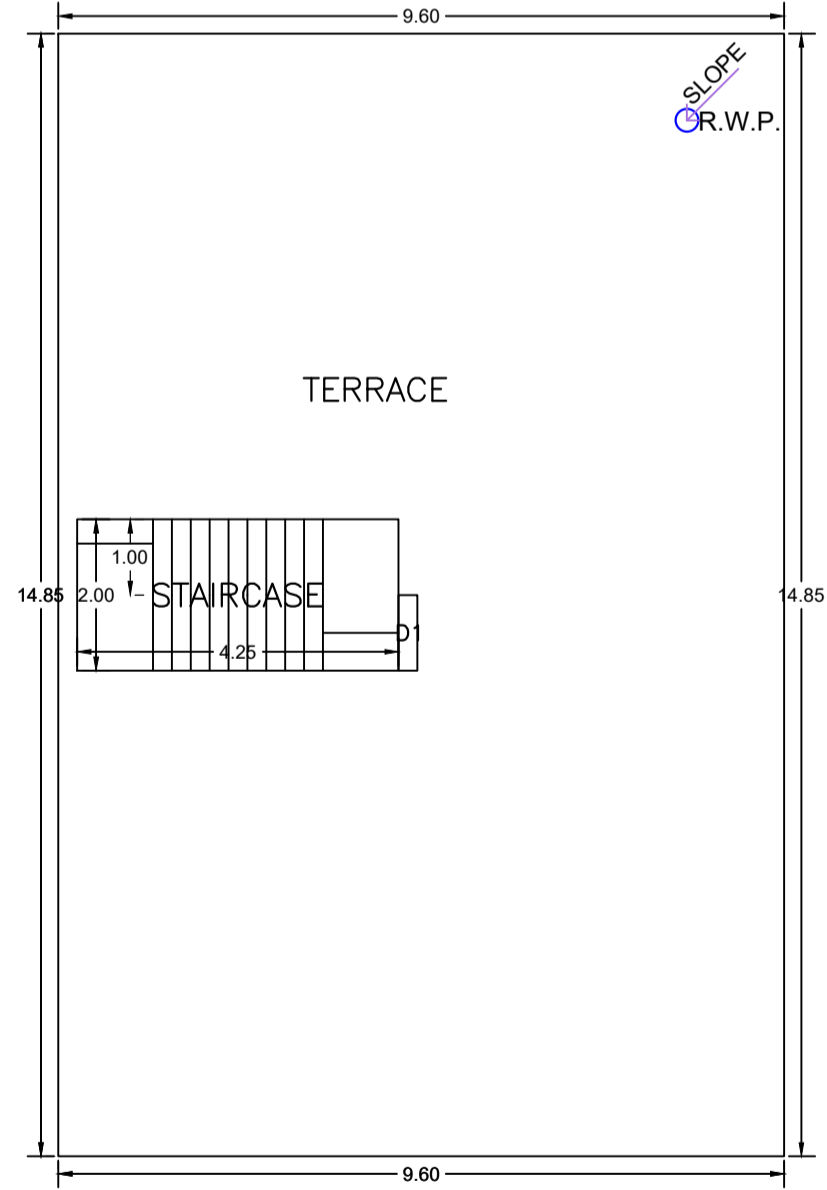
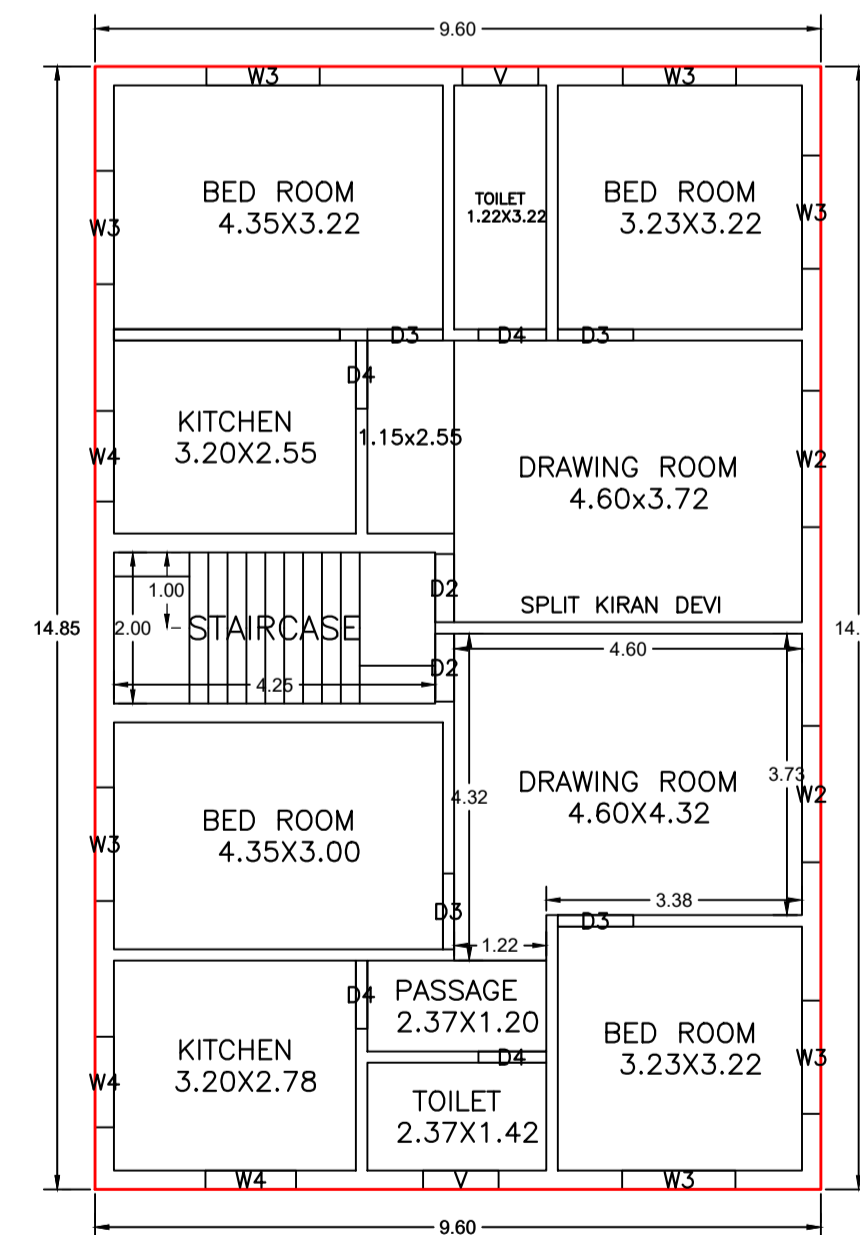
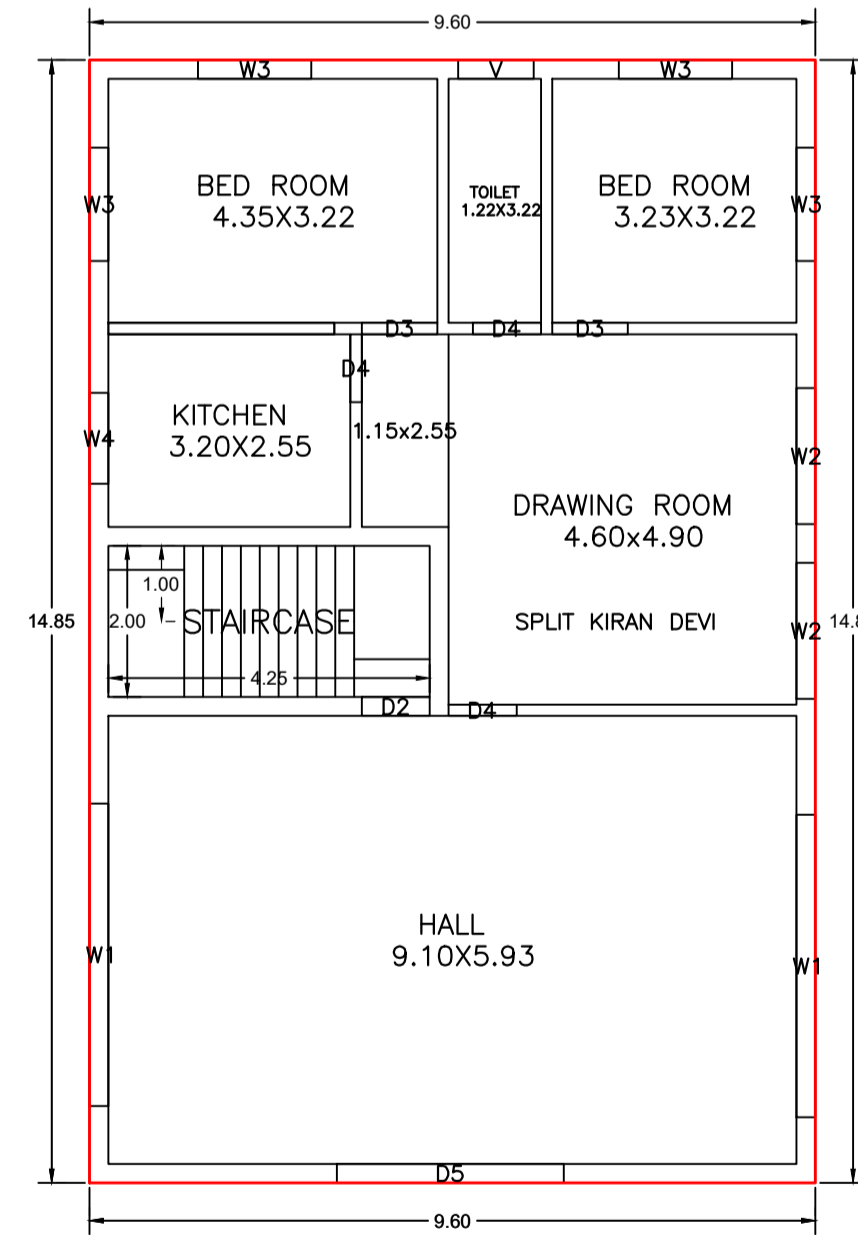
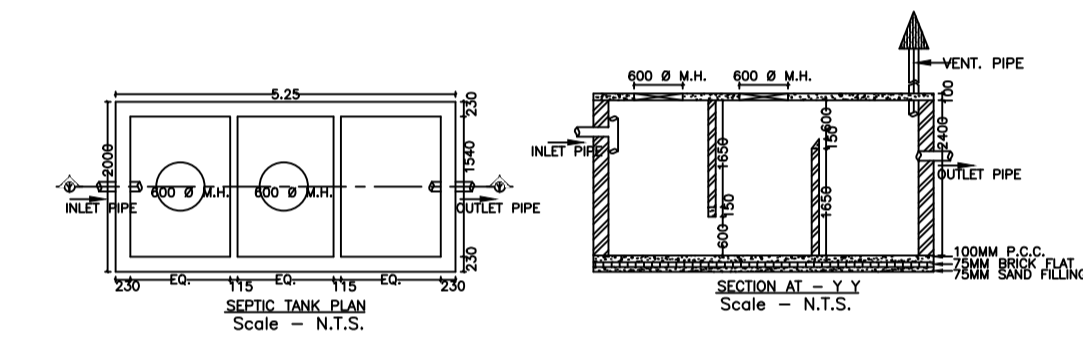
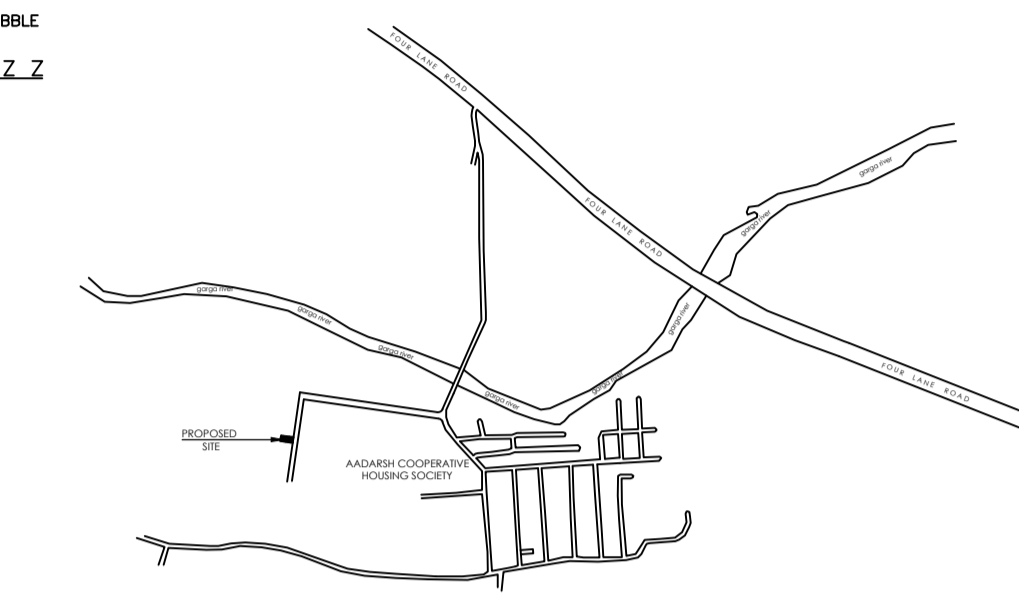
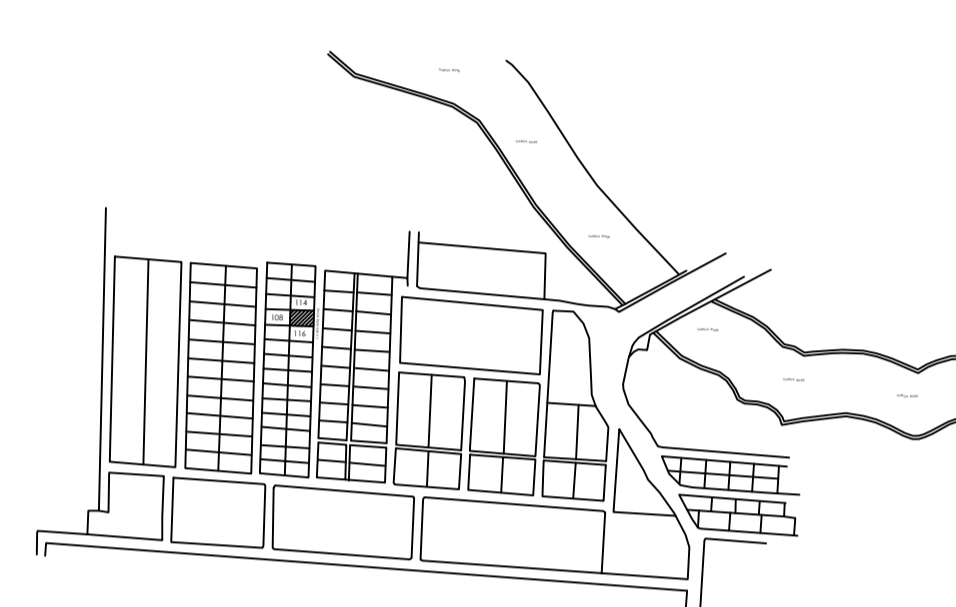
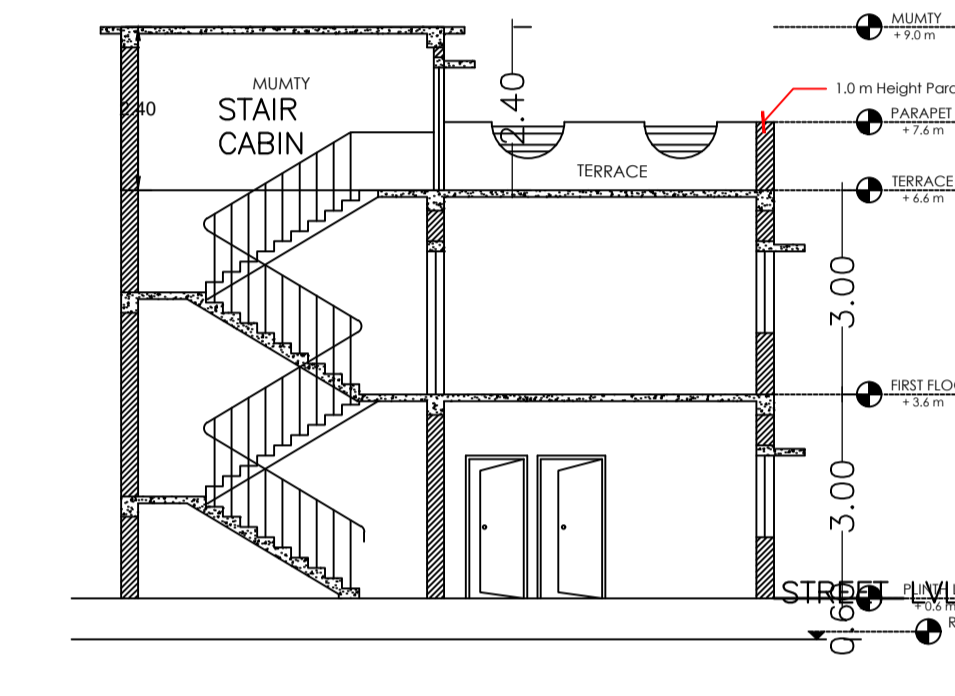
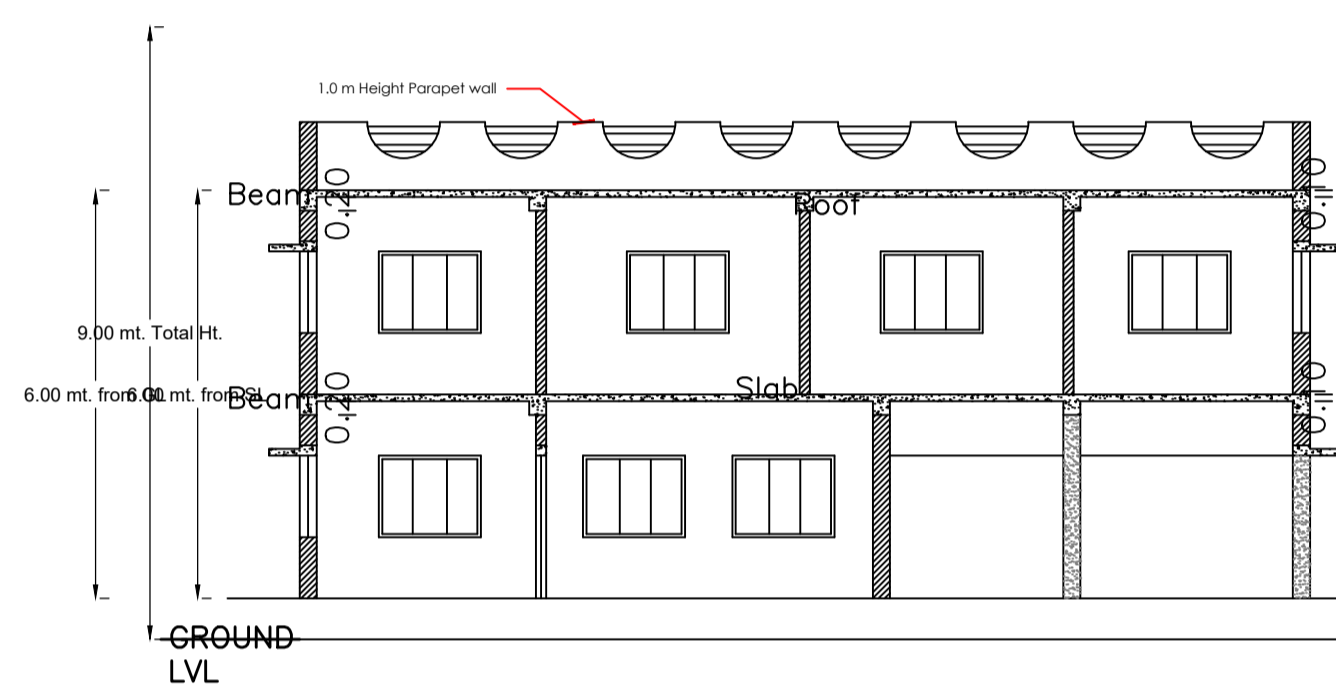
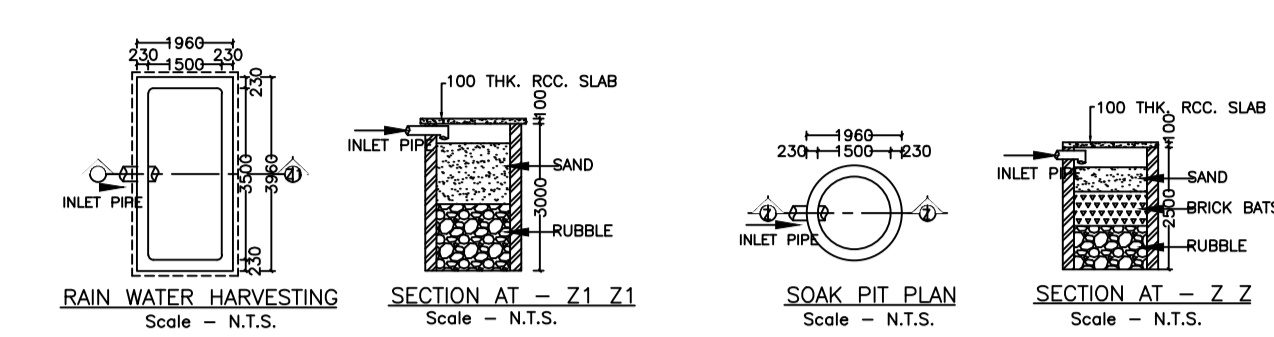
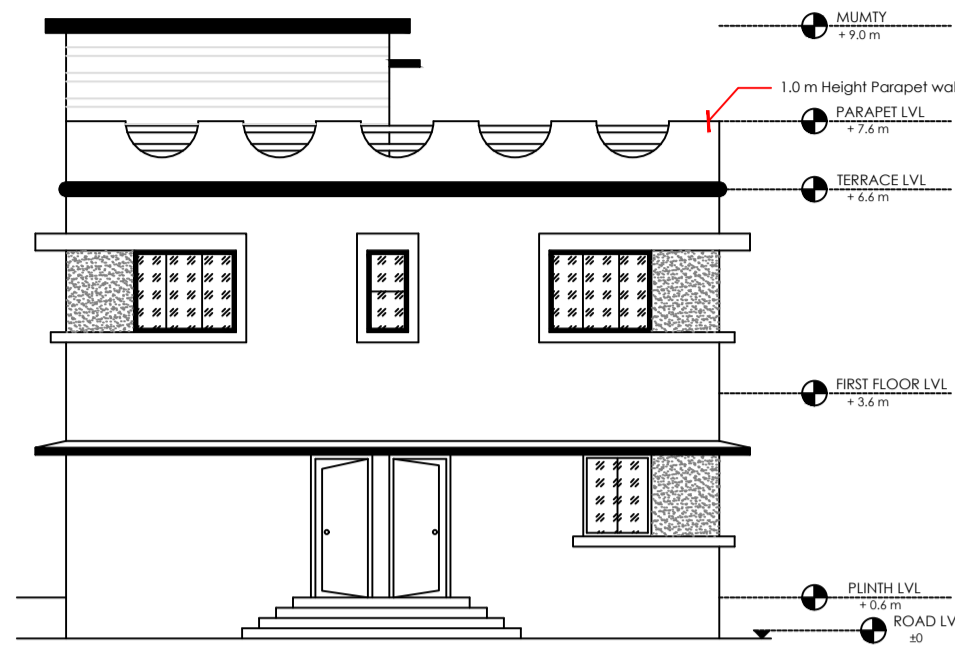
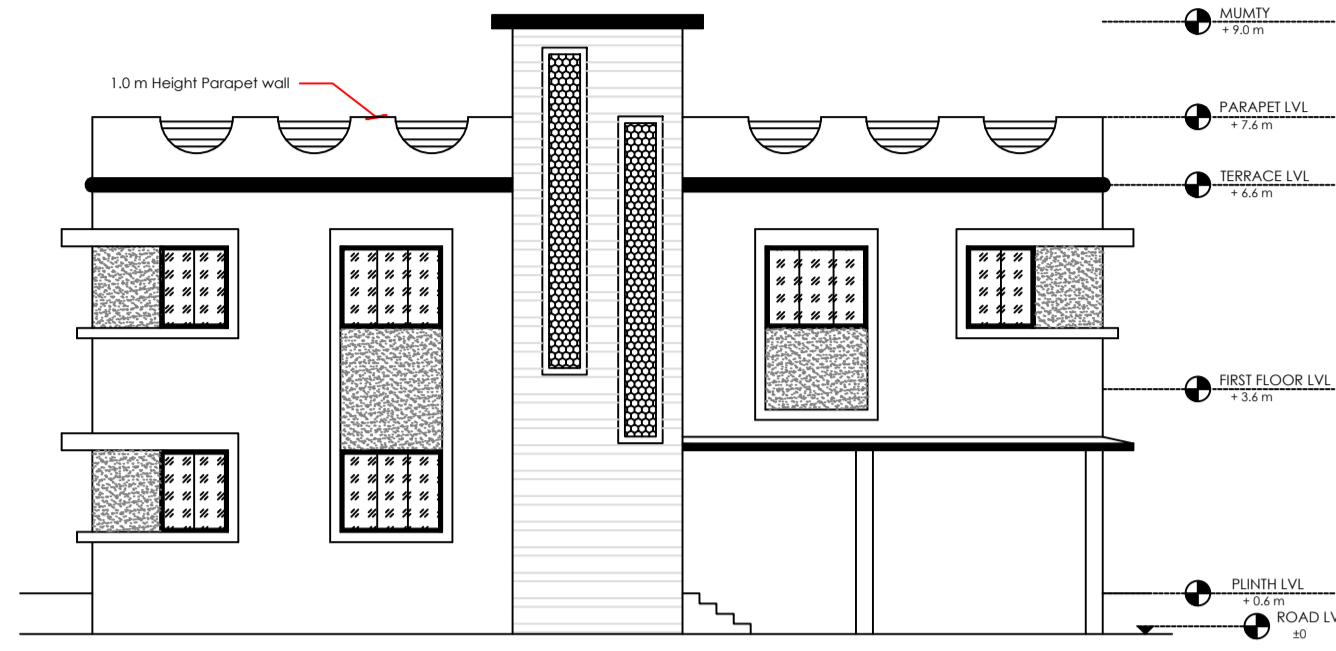
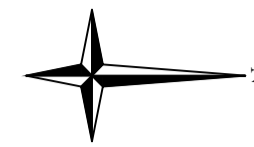

AREA STATEMENT CHAS MUNICIPAL CORPORATION	VERSION NO.: 1.0.70	
PROJECT DETAIL:	VERSION DATE: 16/10/2020	
Region: JHARKHAND URBAN LOCAL BODIES	Plot Use: Residential	
District: BOKARO	Plot SubUse: Bungalow/ Dwelling / Non Apartment	
Authority: CHAS MUNICIPAL CORPORATION	PlotNearbyReligiousStructure: NA	
Inward No: CMC/BP/0072/W30/2024	Plot/SubPlot No: 5, (Co-operative plot no 115)	
Application Type: General Proposal	North: Plot No. - 114	
Project Type: Building Permission	South: Plot No. - 116	
Nature of Development: New	East: Road Width - 7.5	
Location of Development Area: Old Area	West: Plot No. - 108	
AREA DETAILS:		SQ. MT.
AREA OF PLOT (Minimum)	(A)	240.00
NET AREA OF PLOT(Gross Plot Area - Deduction from Gross Plot area)	(A-Deductions)	240.00
Deduction for Balance Plot Area(from Gross Plot Area)		
Common Plot		38.72
Total		38.72
BALANCE AREA OF PLOT(Net Plot Area - Recreational/Amenity space)	(A-Deductions)	201.28
PLOT AREA FOR COVERAGE(Net Plot Area)	(A-Deductions)	240.00
Plot Area for FAR (Net Plot Area + RoadWidening Area)	(A-Deductions)	240.00
COVERAGE CHECK		
Permissible Coverage area (60.00 %)		144.00
Proposed Coverage Area (59.40 %)		142.56
Total Prop. Coverage Area (59.4 %)		142.56
Balance coverage area (0.60 %)		1.44
FAR CHECK		
Perm. FAR Area (2.500)		600.00
Total Perm. FAR area		600.00
Residential FAR		285.12
Proposed FAR Area		285.12
Total Proposed FAR Area		285.12
Consumed FAR (Factor)		1.19
Balance FAR Area		314.88
BUILT UP AREA CHECK		
Total Proposed BuiltUp Area		285.12
ARCHITECT (Regd)	Manish Agarwal	
ENGINEER (Regd)		
SUPERVISOR (Regd)		
OWNER (Regd)	KIRAN DEVI	
DEVELOPMENT AUTHORITY		LOCAL BODY

Building :A (KIRAN DEVI)

Floor Name	Total Built Up Area (Sq.mt.)	Proposed FAR Area (Sq.mt.) Resi.	Total FAR Area (Sq.mt.)	Total Consumed Additional FAR Area (Sq.mt.)	Tnmt (No.)
Ground Floor	142.56	142.56	142.56	142.56	01
First Floor	142.56	142.56	142.56	142.56	00
Terrace Floor	0.00	0.00	0.00	0.00	00
Total :	285.12	285.12	285.12	285.12	01
Total Number of Same Buildings :	1				
Total :	285.12	285.12	285.12	285.12	01

SCHEDULE OF DOOR:

BUILDING NAME	NAME	LENGTH	HEIGHT	NOS
A (KIRAN DEVI)	D4	0.90	2.10	07
A (KIRAN DEVI)	D2	0.90	2.10	03
A (KIRAN DEVI)	D3	1.00	2.10	06
A (KIRAN DEVI)	D5	3.00	2.10	01

SCHEDULE OF WINDOW/VENTILATION:

BUILDING NAME	NAME	LENGTH	HEIGHT	NOS
A (KIRAN DEVI)	V	1.00	1.20	03
A (KIRAN DEVI)	W4	1.20	1.20	04
A (KIRAN DEVI)	W3	1.50	1.20	11
A (KIRAN DEVI)	W2	1.80	1.20	04
A (KIRAN DEVI)	W1	4.00	1.20	02

UnitBUA Table for Building :A (KIRAN DEVI)

FLOOR	Name	UnitBUA Type	UnitBUA Area	Carpet Area	No. of Rooms	No. of Tenement
GROUND FLOOR PLAN	SPLIT KIRAN DEVI	FLAT	244.17	243.27	6	1
FIRST FLOOR PLAN	SPLIT KIRAN DEVI	FLAT	0.00	0.00	11	0
Total:	-	-	244.17	243.27	17	1

Buildingwise Floor FAR Details

Floor Name	Building Name A (KIRAN DEVI)		Total	
	Proposed Built Up Area (Sq.mt.)	Proposed FAR Area (Sq.mt.)	Total Proposed Built Up Area (Sq.mt.)	Total FAR Area (Sq.mt.)
Ground Floor	142.56	142.56	142.56	142.56
First Floor	142.56	142.56	142.56	142.56
Terrace Floor	0.00	0.00	0.00	0.00
Total :	285.12	285.12	285.12	285.12

COLOR INDEX

PLOT BOUNDARY	Black
ABUTTING ROAD	Green
PROPOSED CONSTRUCTION	Red
COMMON PLOT	Yellow
ROAD WIDENING AREA	Blue
EXISTING (To be retained)	Orange
EXISTING (To be demolished)	Light Blue

FAR & Tenement Details (Table 4c-1)

Building	No. of Same Bldg	Total Built Up Area (Sq.mt.)	Proposed FAR Area (Sq.mt.) Resi.	Total FAR Area (Sq.mt.)	Total Consumed Additional FAR Area (Sq.mt.)	Tnmt (No.)
A (KIRAN DEVI)	1	285.12	285.12	285.12	285.12	01
Grand Total :	1	285.12	285.12	285.12	285.12	01

Building USE/SUBUSE Details

Building Name	Building Use	Building SubUse	Building Structure
A (KIRAN DEVI)	Residential	Bungalow/ Dwelling / Non Apartment	Non-Highrise

LTP NAME AND SIGNATURE	STRUCTURAL ENG'S NAME AND SIGNATURE	BUILDER NAME AND SIGNATURE	DIGITAL SIGNATURE
Manish Agarwal CMC/ARC/0003/2018			