

Proposal Basic Information	
Proposal File No.	CMC/BP/0155/W08/2024
Owner Name	REHANA BEGAM
Khata No	20
Plot No	4034
Village Name	Chas
Use	Residential
SubUse	Bungalow/ Dwelling / Non Apartment

AREA STATEMENT CHAS MUNICIPAL CORPORATION		VERSION NO. : 1.0.73
PROJECT DETAIL:		VERSION DATE: 16/10/2020
Region: JHARKHAND URBAN LOCAL BODIES	Plot Use: Residential	SQ. MT.
District: BOKARO CORPORATION	Plot SubUse: Bungalow/ Dwelling / Non Apartment	
Authority: CHAS MUNICIPAL CORPORATION	PlotNearbyReligiousStructure: NA	
Inward_No: CMC/BP/0155/W08/2024	PlotSubPlot No: 4034	
Application Type: General Proposal	North: CTS No. - PART OF PLOT	
Project Type: Building Permission	South: Road Width - PART OF PLOT	
Nature of Development: New	East: Plot No. - 4015	
Location of Development Area: Old Area	West: Road Width - 3.6	
AREA DETAILS:		
AREA OF PLOT (Minimum)	(A)	132.09
NET AREA OF PLOT(Gross Plot Area - Deduction from Gross Plot area)	(A-Deductions)	132.09
Deduction for Balance Plot Area(from Gross Plot Area)		
Common Plot		12.56
Total		12.56
BALANCE AREA OF PLOT(Net Plot Area - Recreational/Amenity space)	(A-Deductions)	119.53
PLOT AREA FOR COVERAGE(Net Plot Area)	(A-Deductions)	132.09
Plot Area for FAR (Net Plot Area + Road Widening Area)	(A-Deductions)	132.09
COVERAGE CHECK		
Permissible Coverage area (70.00 %)		92.46
Proposed Coverage Area (82.53 %)		82.59
Total Prop. Coverage Area (62.53 %)		82.59
Balance coverage area (7.47 %)		9.87
FAR CHECK		
Perm. FAR Area (1.500)		198.13
Total Perm. FAR area		198.13
Residential FAR		165.19
Proposed FAR Area		165.19
Total Proposed FAR Area		165.19
Consumed FAR (Factor)		1.25
Balance FAR Area		32.94
BUILT UP AREA CHECK		
Total Proposed BuiltUp Area		165.18
ARCHITECT (Regd)	MANOJ KUMAR	
ENGINEER (Regd)		
SUPERVISOR (Regd)		
OWNER (Regd)	REHANA BEGAM	
DEVELOPMENT AUTHORITY		LOCAL BODY

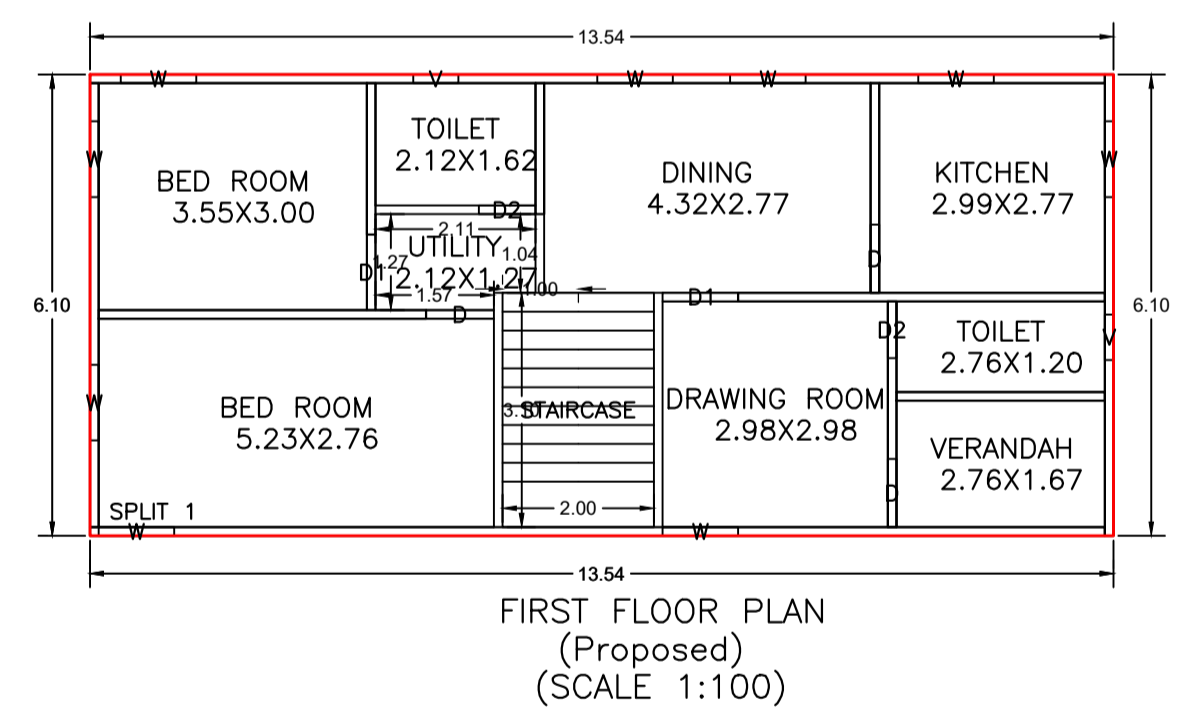
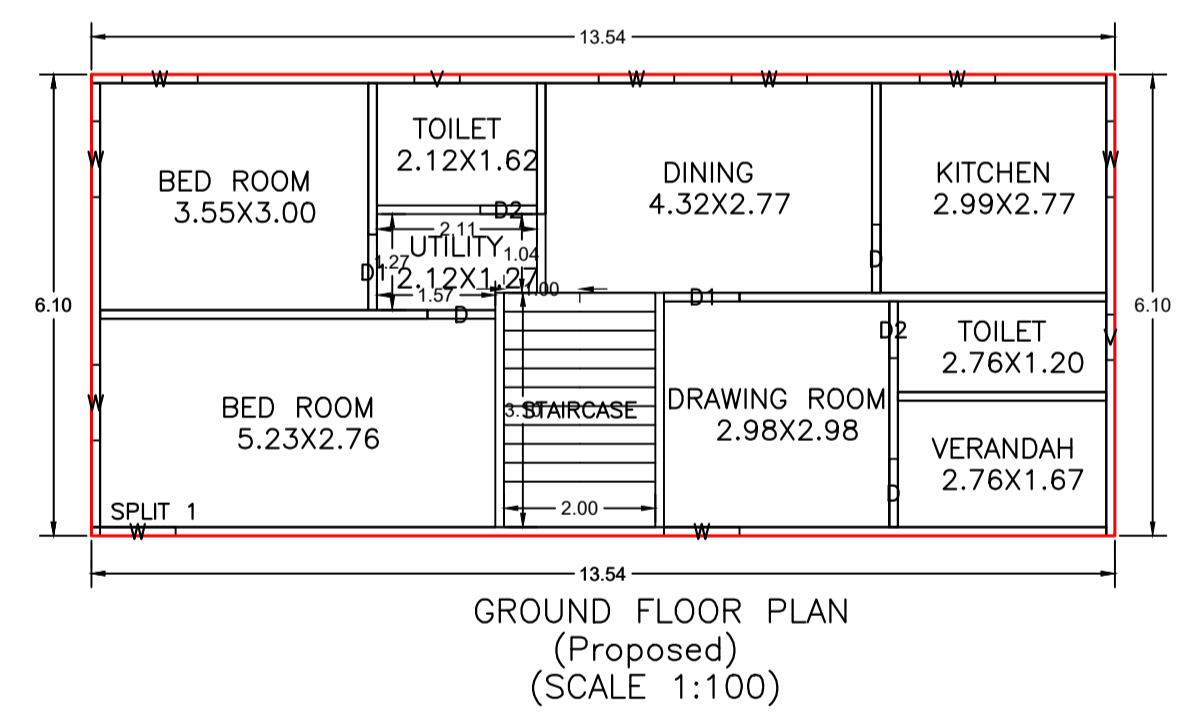
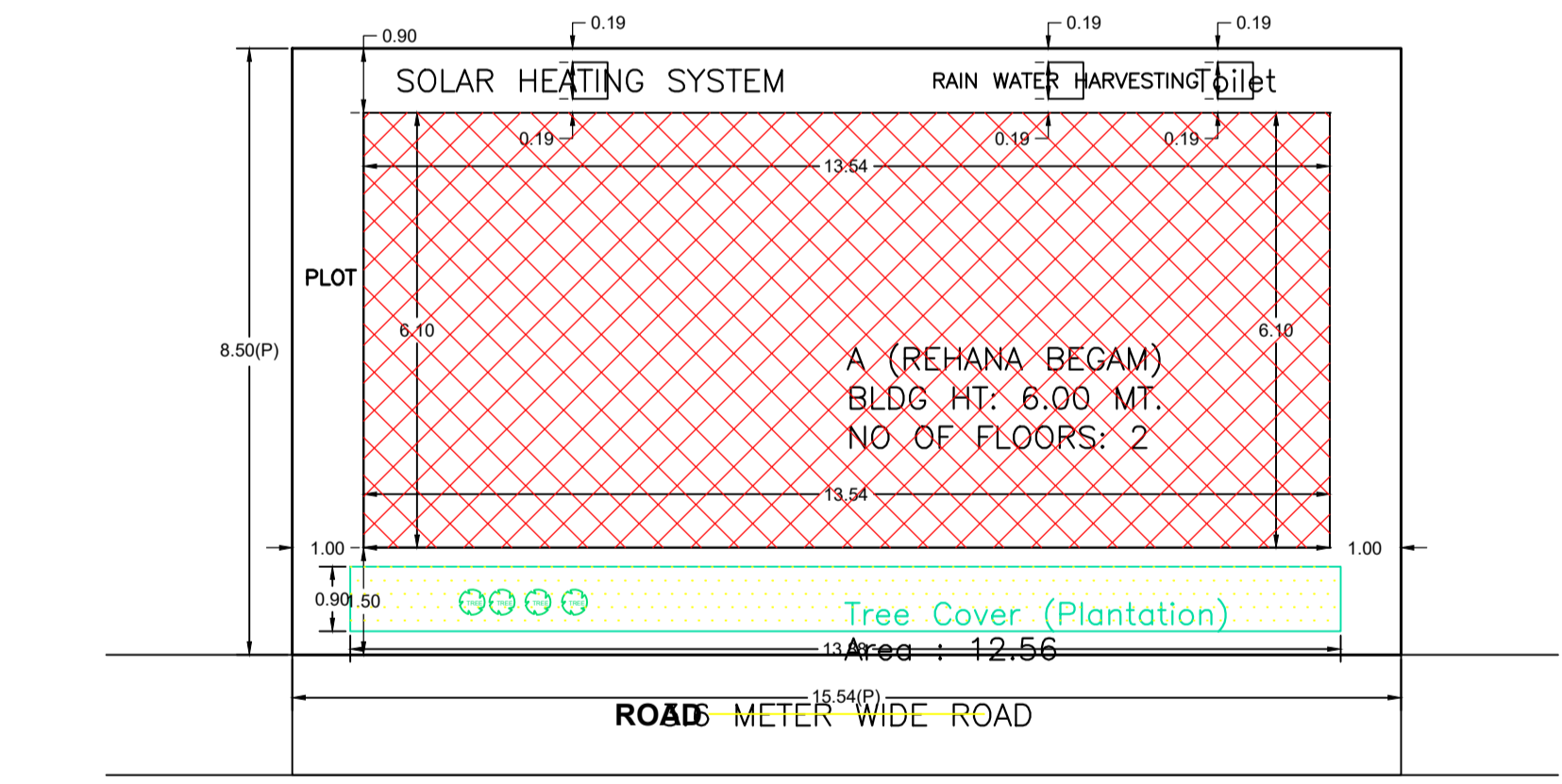
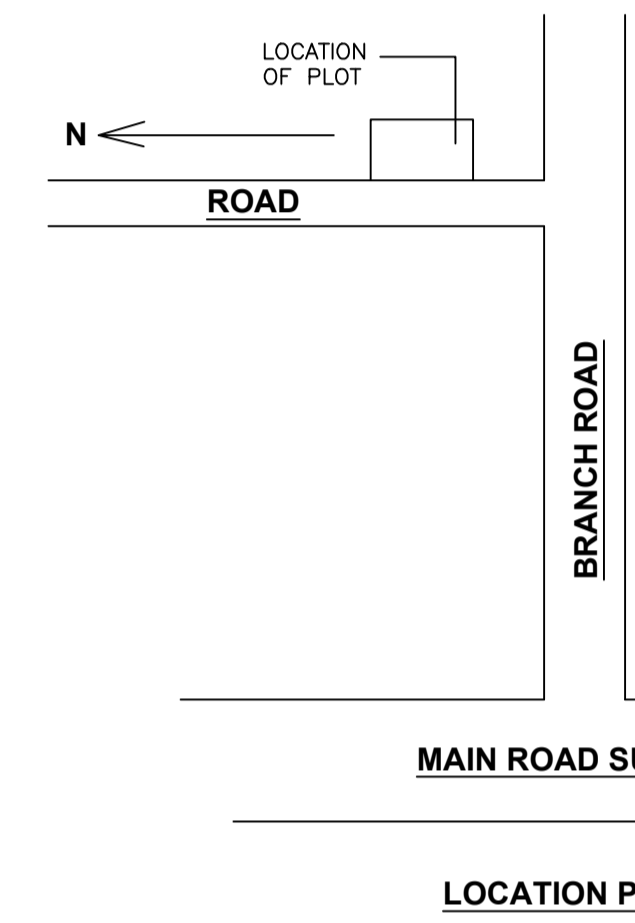
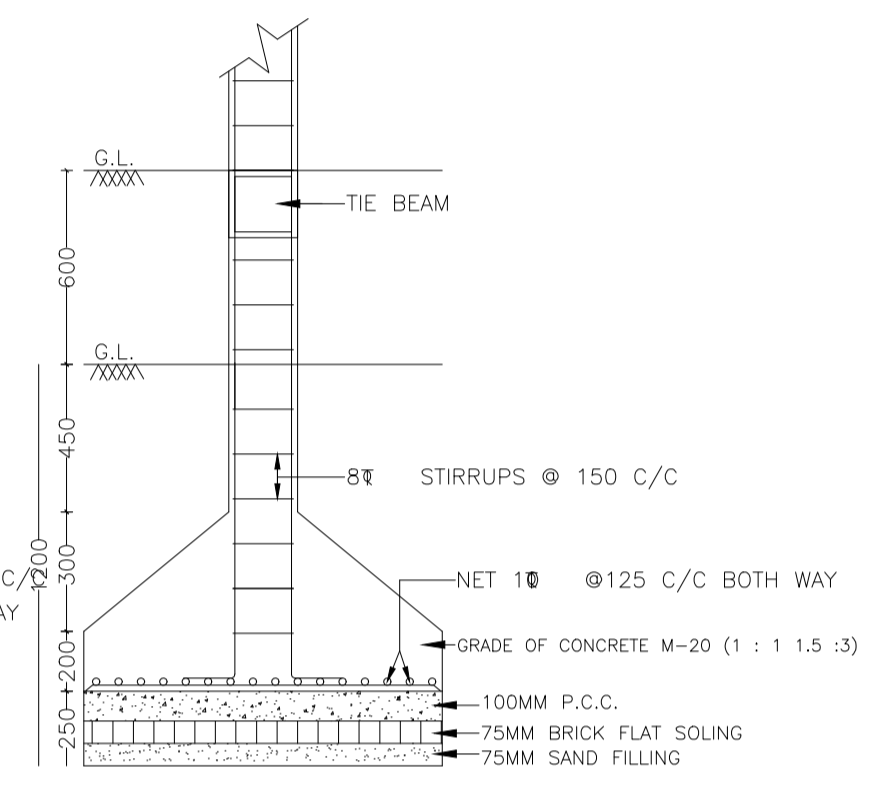
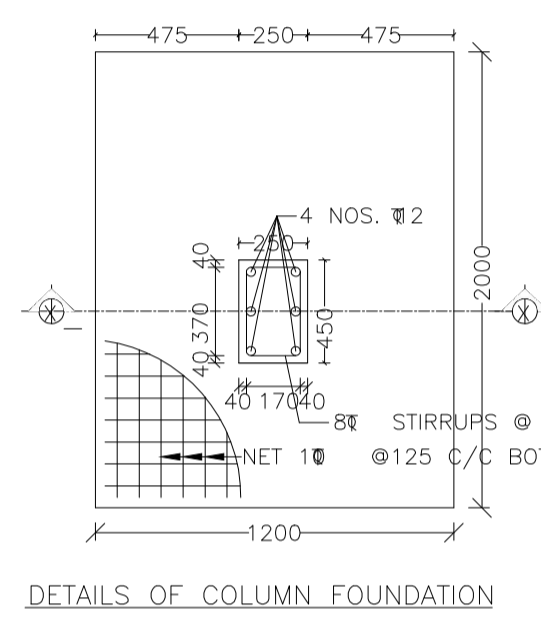
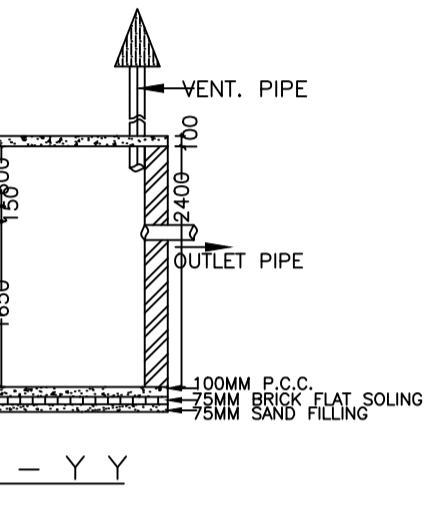
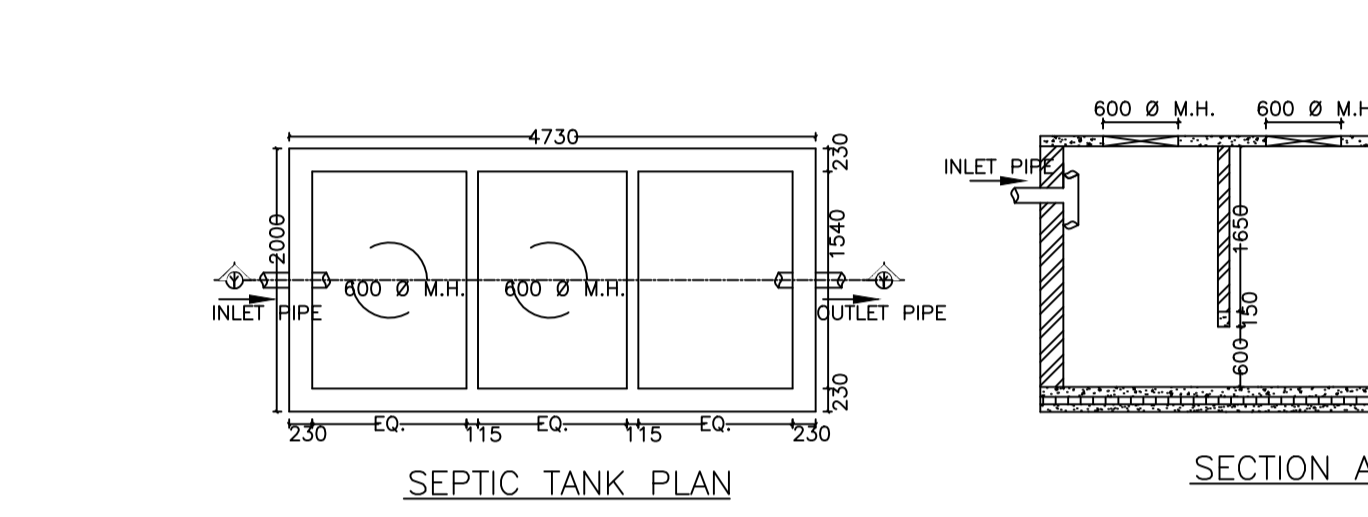

COLOR INDEX	
PLOT BOUNDARY	Black
ABUTTING ROAD	Red
PROPOSED CONSTRUCTION	Green
COMMON PLOT	Yellow
ROAD WIDENING AREA	Orange
EXISTING (To be retained)	Blue
EXISTING (To be demolished)	Light Blue

Floor Name	Building Name		Total	
	Proposed Built Up Area (Sq.mt.)	Proposed FAR Area (Sq.mt.)	Total Proposed Built Up Area (Sq.mt.)	Total FAR Area (Sq.mt.)
Ground Floor	82.59	82.59	82.59	82.59
First Floor	82.59	82.59	82.59	82.59
Terrace Floor	0.00	0.00	0.00	0.00
Total :	165.18	165.18	165.18	165.18

Building USE/SUBUSE Details									
Building Name	Building Use	Building SubUse	Building Structure	Floor Name	Floor Use	Floor SubUse	FAR Name	FAR Use	FAR SubUse
A (REHANA BEGAM)	Residential	Bungalow/ Dwelling / Non Apartment	Non-Highrise	GROUND FLOOR PLAN	Residential	Bungalow/ Dwelling / Non Apartment	Residential FAR	Residential	Bungalow/ Dwelling / Non Apartment
				FIRST FLOOR PLAN	Residential	Bungalow/ Dwelling / Non Apartment	Residential FAR	Residential	Bungalow/ Dwelling / Non Apartment
				TERRACE FLOOR PLAN	Residential	Bungalow/ Dwelling / Non Apartment	-	-	-

FAR & Tenement Details (Table 4c-1)					
Building	No. of Same Bldg	Total Built Up Area (Sq.mt.)	Proposed FAR Area (Sq.mt.)	Total Consumed Additional FAR Area (Sq.mt.)	Tnmt (No.)
A (REHANA BEGAM)	1	165.18	165.18	165.18	01
Grand Total :	1	165.18	165.18	165.18	01

Building :A (REHANA BEGAM)					
Floor Name	Total Built Up Area (Sq.mt.)	Proposed FAR Area (Sq.mt.)	Total FAR Area (Sq.mt.)	Total Consumed Additional FAR Area (Sq.mt.)	Tnmt (No.)
Ground Floor	82.59	82.59	82.59	82.59	01
First Floor	82.59	82.59	82.59	82.59	00
Terrace Floor	0.00	0.00	0.00	0.00	00
Total :	165.18	165.18	165.18	165.18	01
Total Number of Same Buildings	1				
Total :	165.18	165.18	165.18	165.18	01

SCHEDULE OF DOOR:					
BUILDING NAME	NAME	LENGTH	HEIGHT	NOS	
A (REHANA BEGAM)	D2	0.75	2.10	04	
A (REHANA BEGAM)	D	0.90	2.10	06	
A (REHANA BEGAM)	D1	1.00	2.10	04	

UnitBUA Table for Building :A (REHANA BEGAM)						
FLOOR	Name	UnitBUA Type	UnitBUA Area	Carpel Area	No. of Rooms	No. of Tenement
GROUND FLOOR PLAN	SPLIT 1	FLAT	142.43	137.51	9	1
FIRST FLOOR PLAN	SPLIT 1	FLAT	0.00	0.00	9	0
Total:	-	-	142.43	137.51	18	1

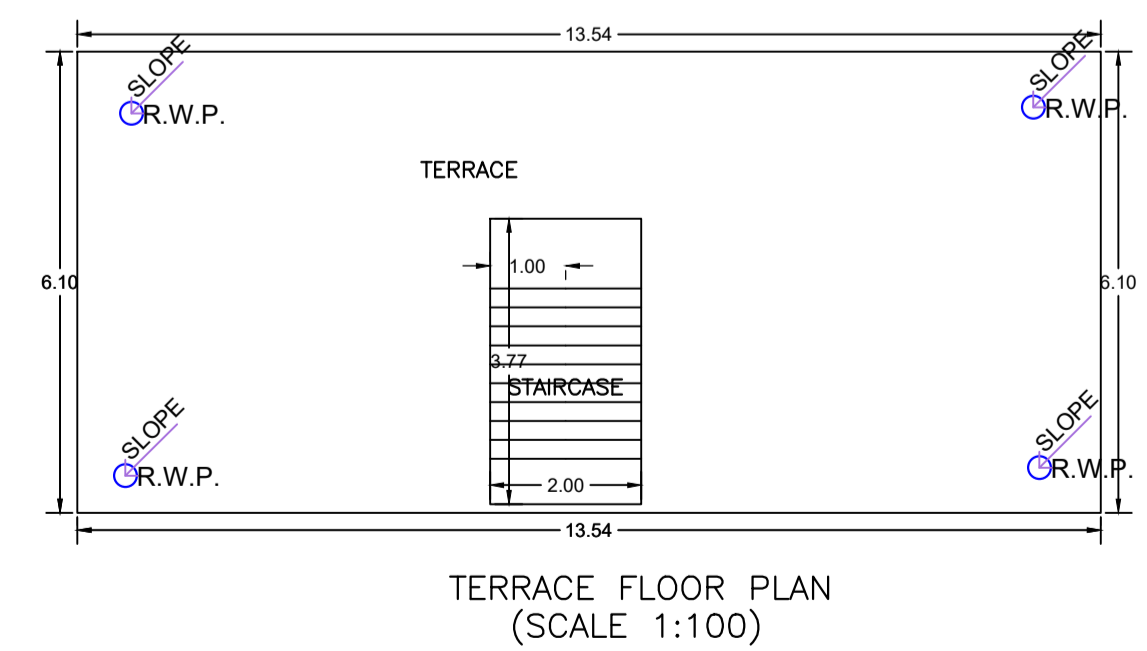

LTP NAME AND SIGNATURE	STRUCTURAL ENG'S NAME AND SIGNATURE	BUILDER NAME AND SIGNATURE	DIGITAL SIGNATURE
MANOJ KUMAR CMC/SUP/0016/2018			