

Project Title : RAMESHWAR PRASAD

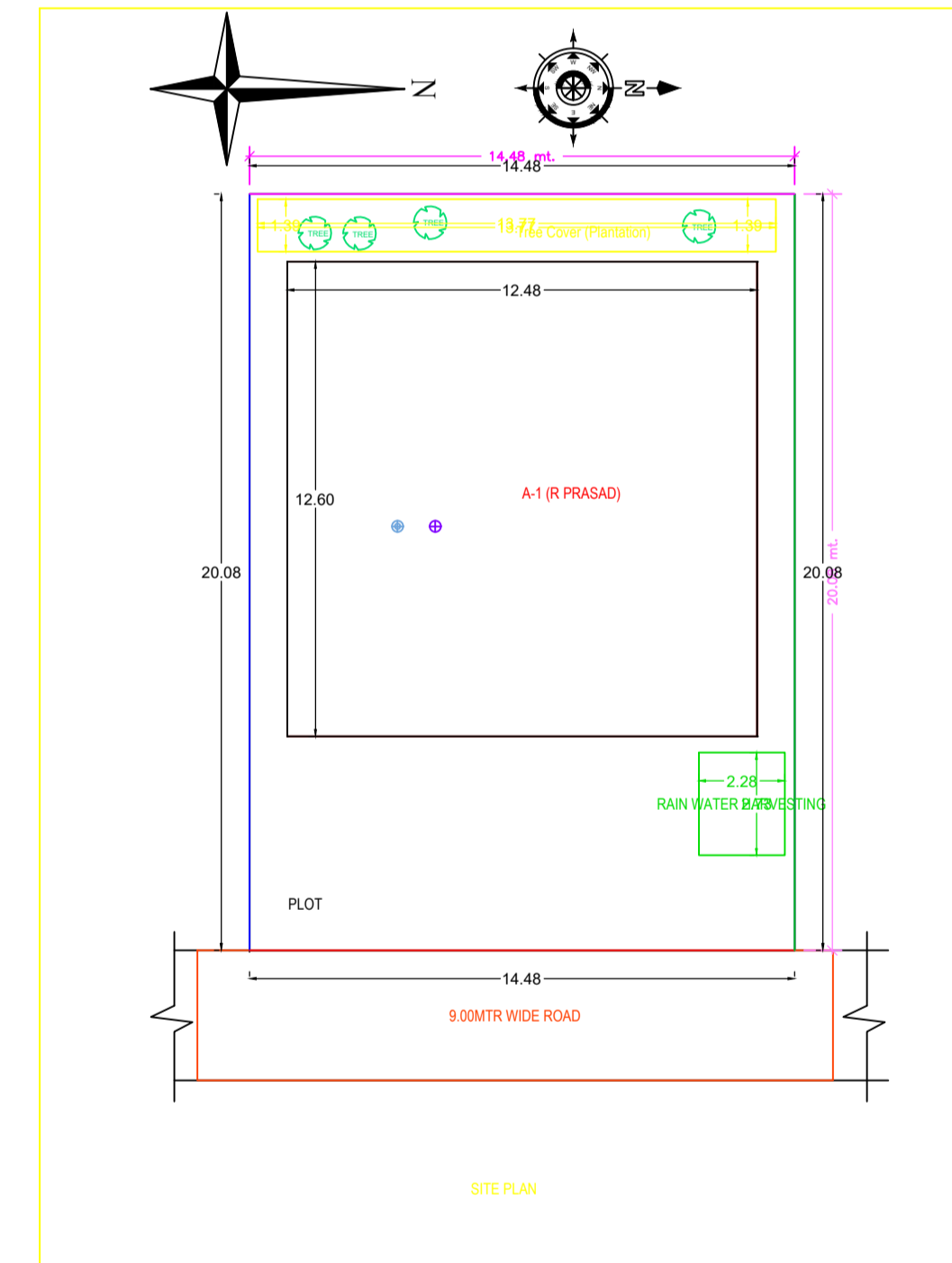
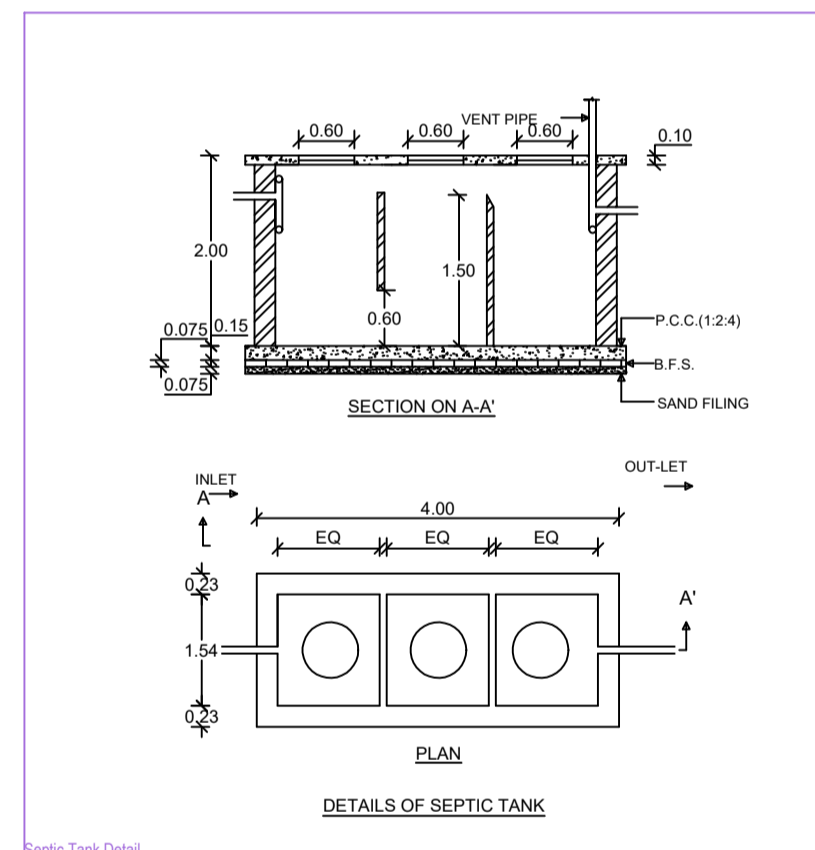
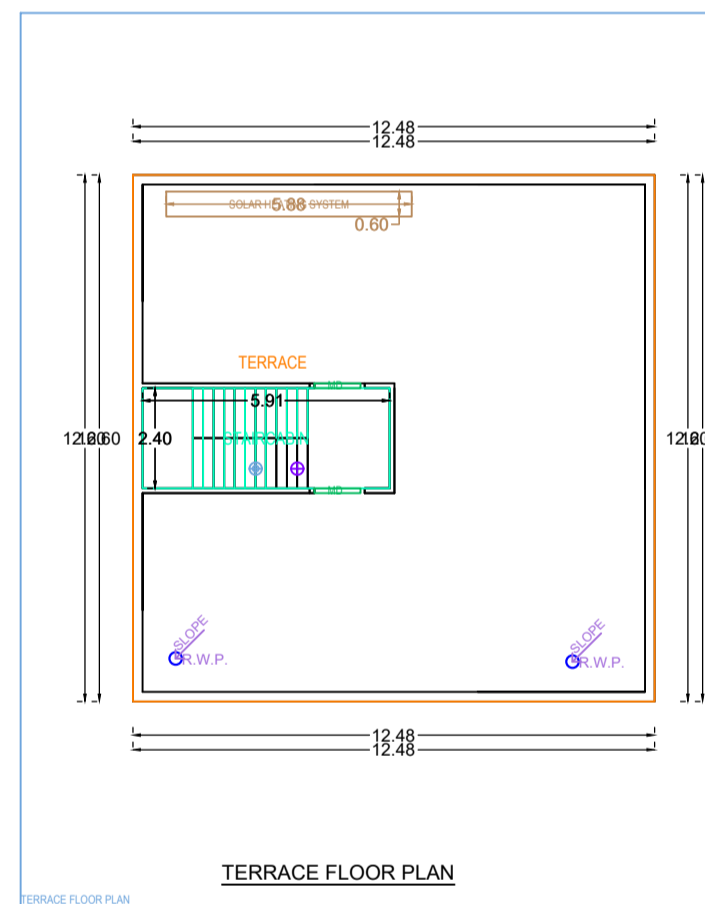
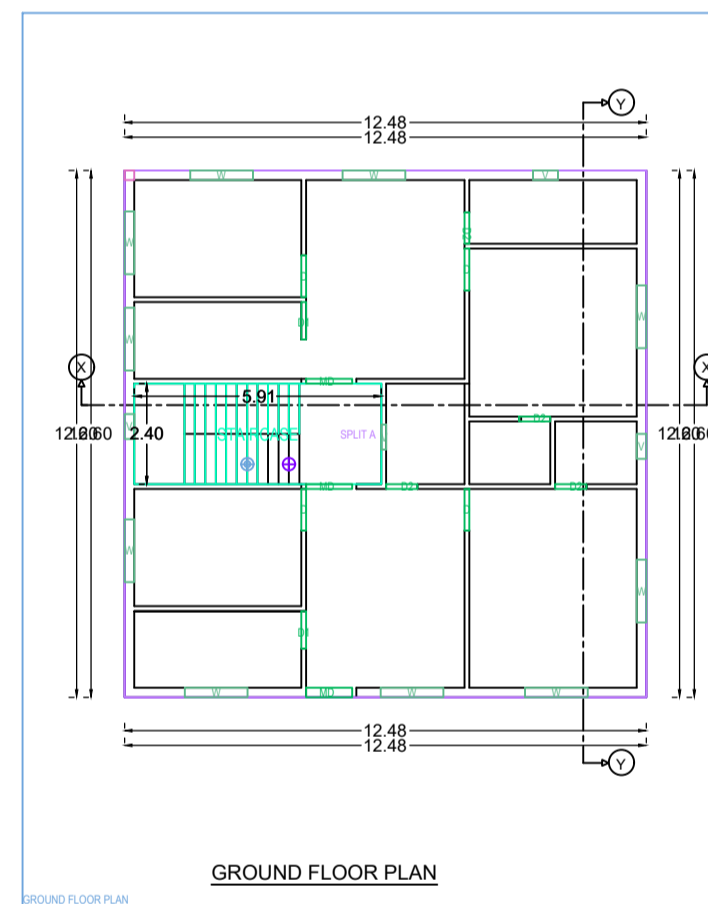
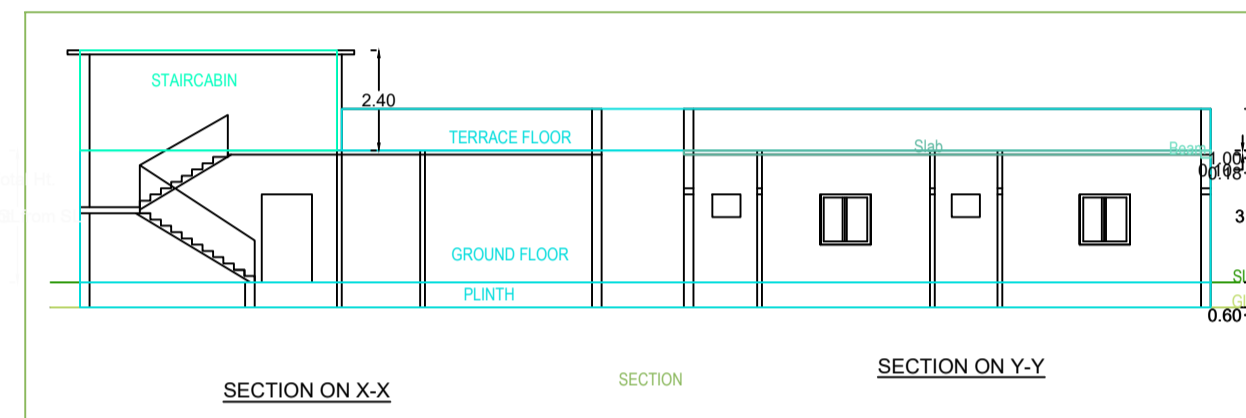
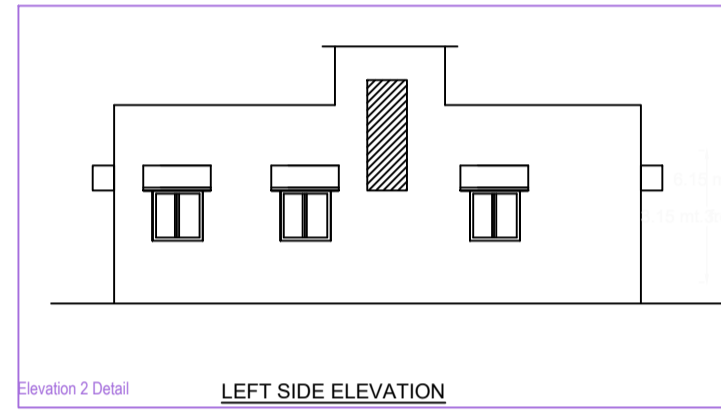
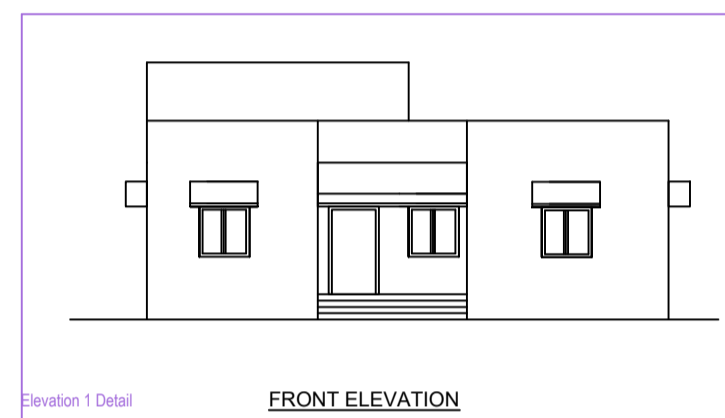
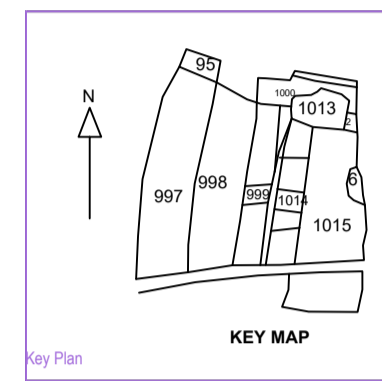
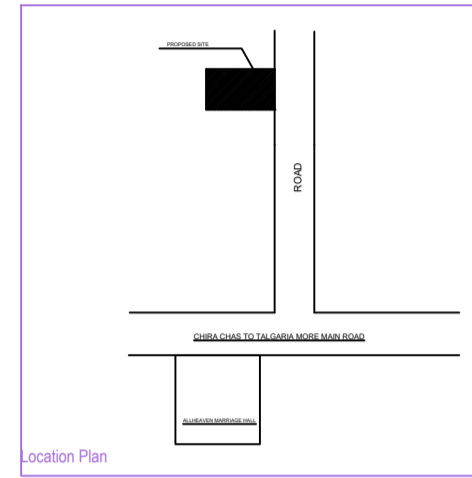
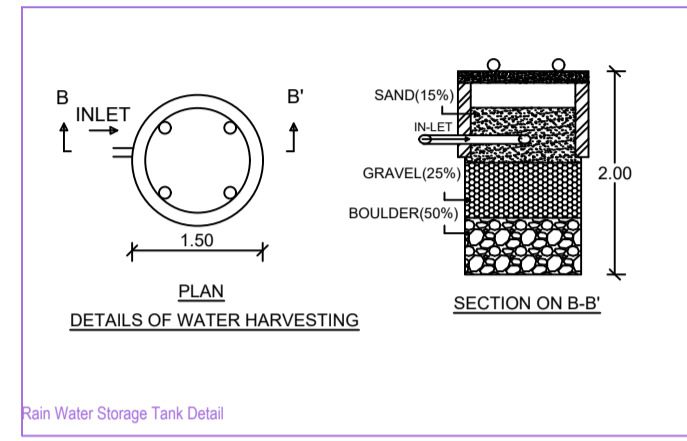
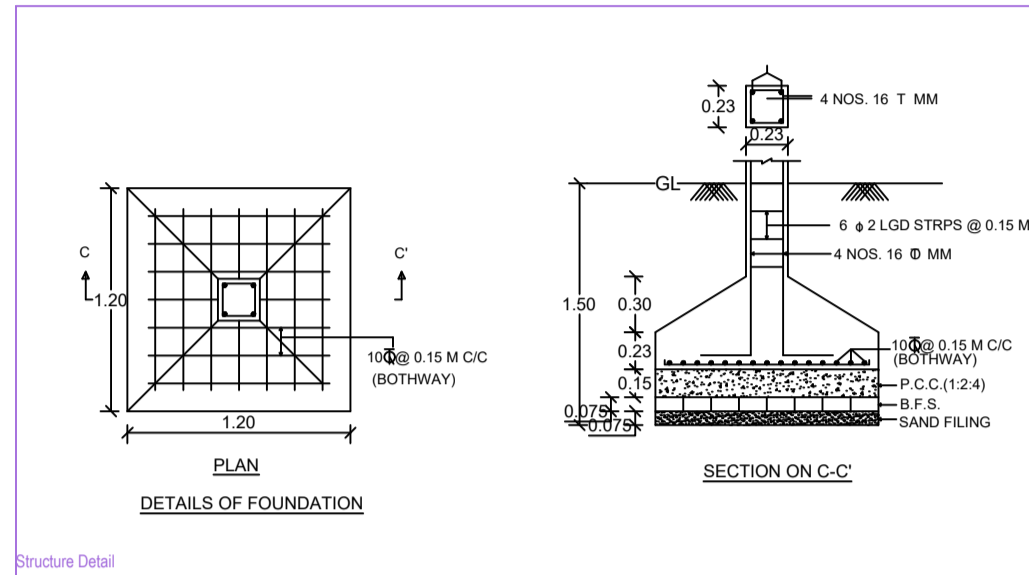

Building A (R PRASAD)

Floor Name	Total Built Up Area (Sq. m.)	Proposed FAR Area (Sq. m.)	Total FAR Area (Sq. m.)	Floor (No.)
Ground Floor	157.25	157.25	157.25	01
Terrace Floor	157.25	157.25	314.50	02
Total	314.50	314.50	314.50	02

SCHEDULE OF JOINERY

BUILDING NAME	NAME	LENGTH	HEIGHT	NO. OF
A (R PRASAD)	DO	0.75	2.10	04
A (R PRASAD)	DI	0.50	2.10	02
A (R PRASAD)	DD	1.00	2.10	04
A (R PRASAD)	DE	1.50	2.10	06
Total				16

SCHEDULE OF JOINERY

BUILDING NAME	NAME	LENGTH	HEIGHT	NO. OF
A (R PRASAD)	V	0.50	1.50	04
A (R PRASAD)	W	1.00	1.50	10
Total				14

UHBQA Table for Building A (R PRASAD)

FLOOR	Name	UHBQA Type	UHBQA Area	Carpet Area	No. of Rooms	No. of Staircases
GROUND FLOOR	FLAT A	FLAT	157.25	157.25	12	1
TERRACE FLOOR	-	-	157.25	157.25	12	1

AREA STATEMENT	CRAM MUNICIPAL CORPORATION	VERSION NO. 12.38
PROJECT DETAIL <td>Project Name: RAMESHWAR PRASAD</td> <td>VERSION DATE: 16/10/2020</td>	Project Name: RAMESHWAR PRASAD	VERSION DATE: 16/10/2020
Project No.	Plot No. 1013	
Region: APPROVED URBAN LOCAL BODIES	Plot Use: Residential	
District: BANGALORE	Plot Section: (Single/Double/ Trip Apartment)	
Application Type: General Purpose	Land Use Zone: Residential	
Project Type: Building Permission	Plot No.:	
Name of Applicant: New	Reference Survey No/Survey No.:	
Location: City Area	Town No.:	
Sub-Location: NA	Holding No.:	
Ward No.:	Area No.:	
Phase/Block:	Block No.:	
	Phase:	
	Block:	

AREA DETAILS		SQ.MT
AREA OF PLOT (Reference)	Plot	296.81
Net POC Area (Cover POC Area)	(A-Deductions)	296.81
Deduction from Gross POC Area		0.00
Net POC Area (Cover POC Area)		296.81
Reference POC Area (Net POC Area)	(A-Deductions)	271.63
Specialized/Accessory area		15.18
POC Area for Coverage (Net POC Area)	(A-Deductions)	286.61
Specialized/Accessory area		15.18
POC Area for Coverage (Net POC Area)	(A-Deductions)	271.43
Specialized/Accessory area		15.18
Net Coverage Area (G.O.P. %)		157.25
COVERAGE CHECK		
Proposed Coverage Area (G.O.P. %)		157.25
Net Coverage Area (G.O.P. %)		157.25
COVERAGE CHECK		
Proposed Area of POC		157.25
Net Coverage Area		157.25
COVERAGE CHECK		
Net Coverage Area		157.25
COVERAGE CHECK		
Net Coverage Area		157.25

Building Type	Road Name	Front Margin	Rear Margin	Side Margin	Setback Margin
A (R PRASAD)	9.00MTR WIDE ROAD	1.00	1.00	1.00	1.00

Building	No. of Same Story	Total Built Up Area (Sq. m.)	Proposed FAR Area (Sq. m.)	Total FAR Area (Sq. m.)	Floor (No.)
A (R PRASAD)	1	314.50	314.50	314.50	02
Grand Total	1	314.50	314.50	314.50	02