

Proposal Basic Information

Proposal File No.	CMC/BP/0134/W07/2024
Owner Name	PUSHPA DEVI
Khata No	246
Plot No	2486
Village Name	Chas
Use	Residential
SubUse	Bungalow/ Dwelling / Non Apartment

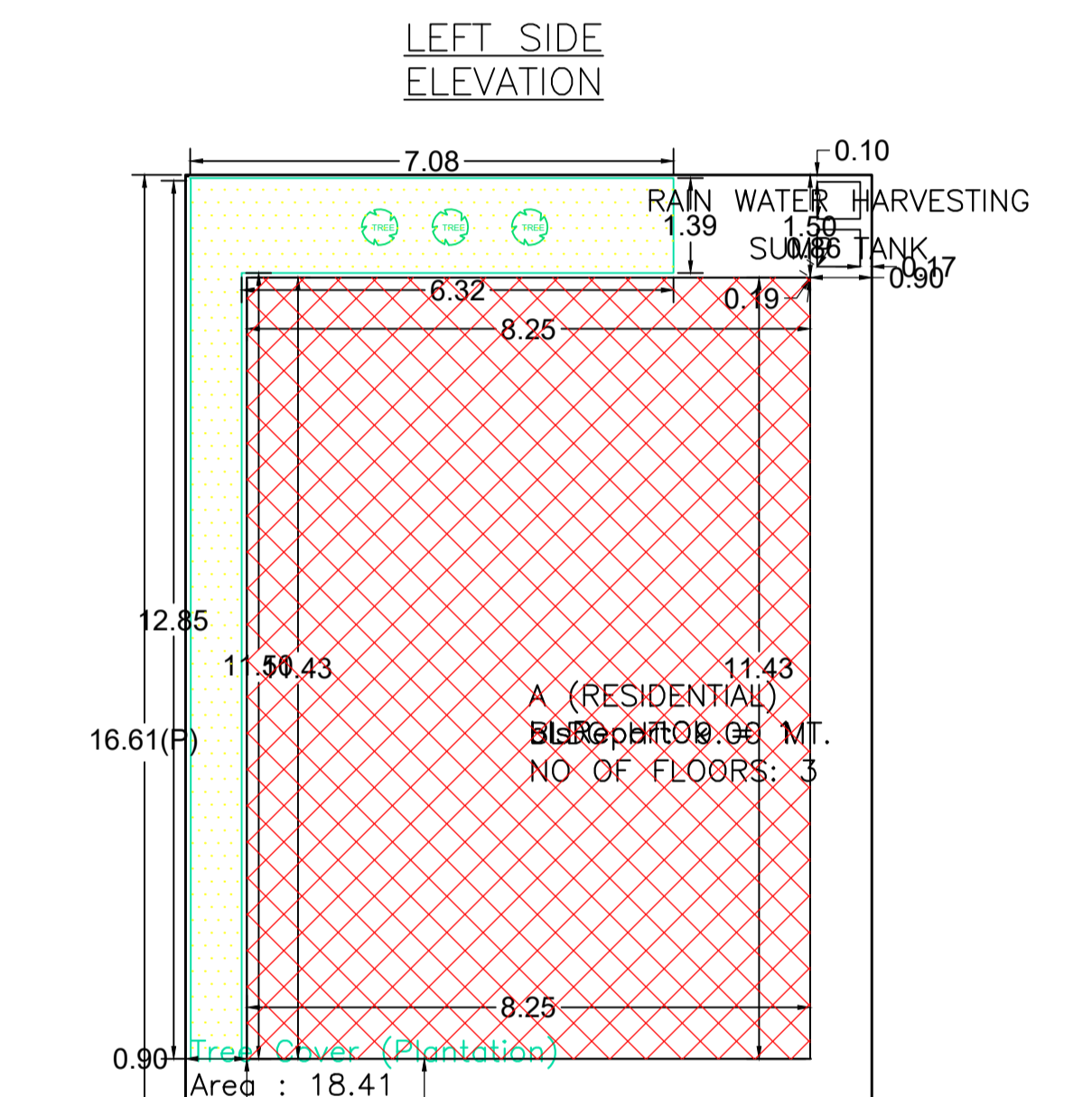
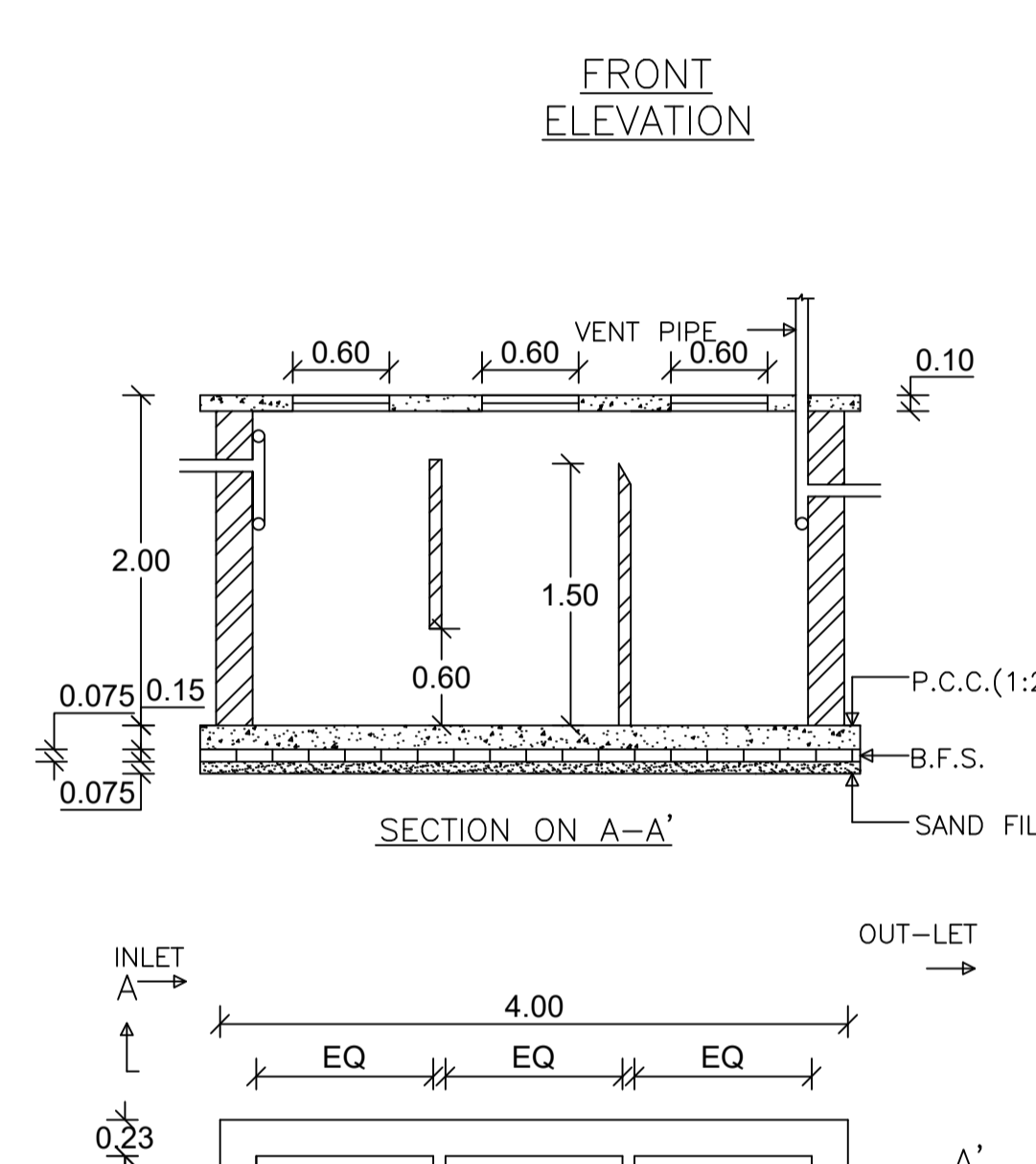
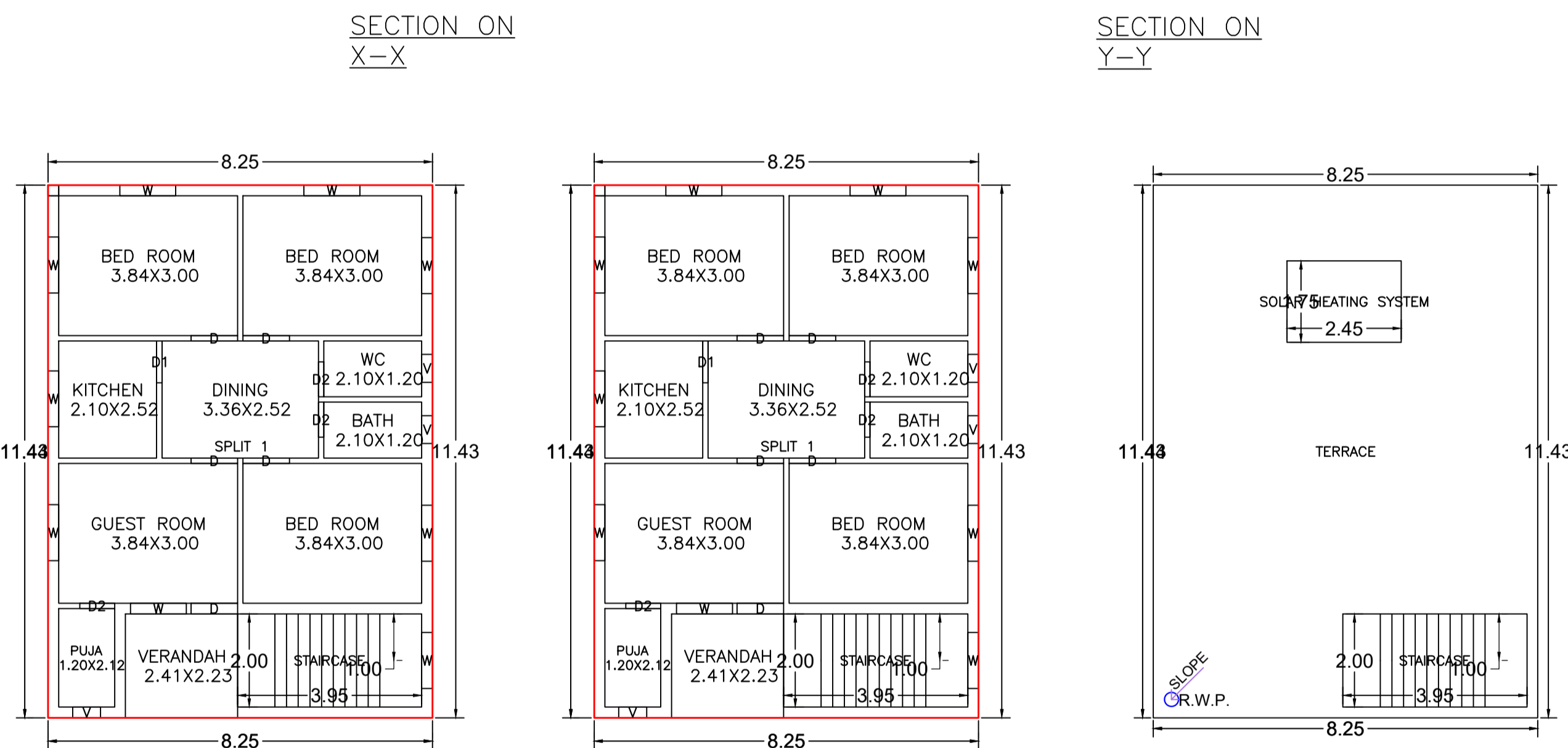
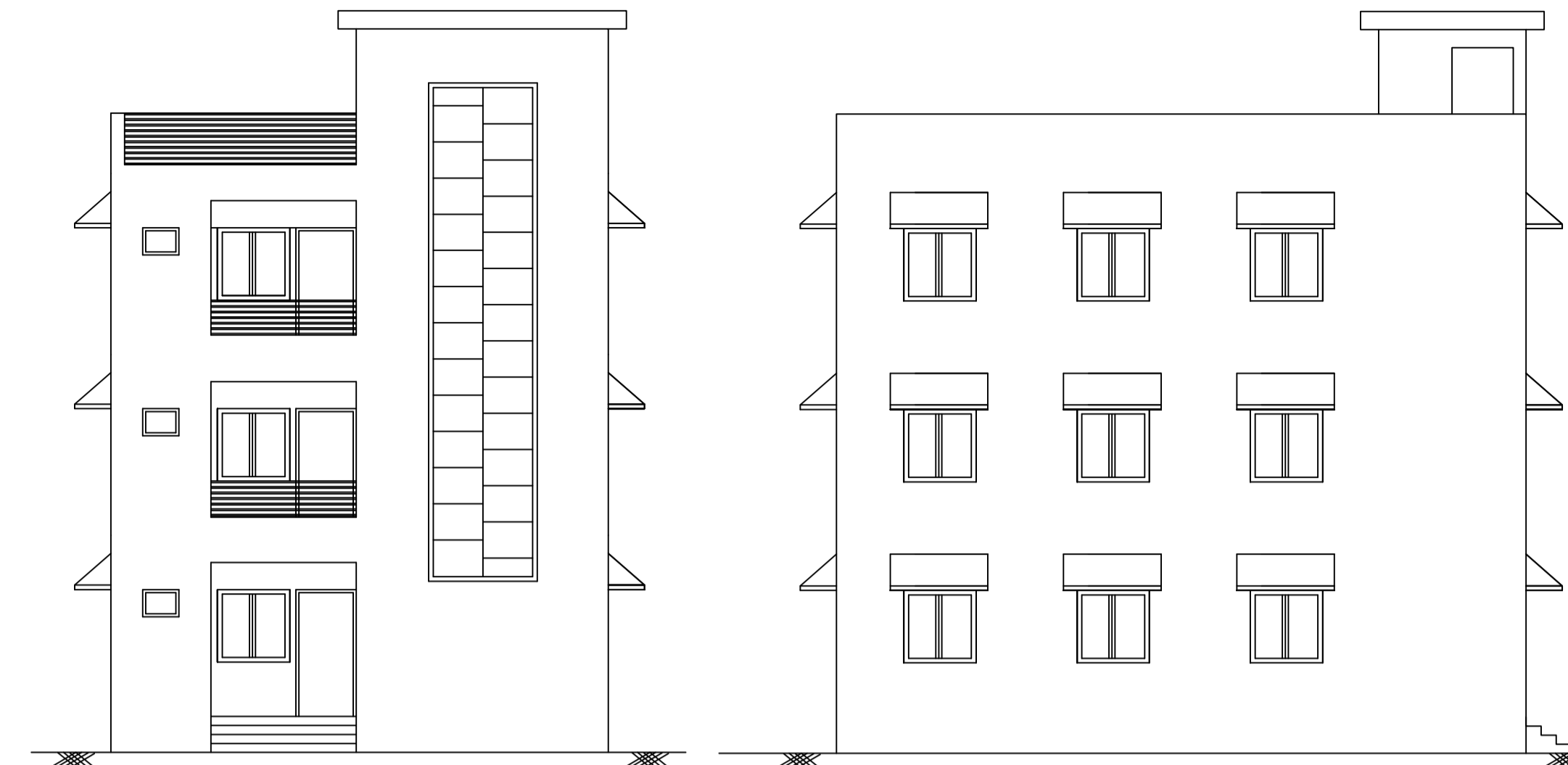
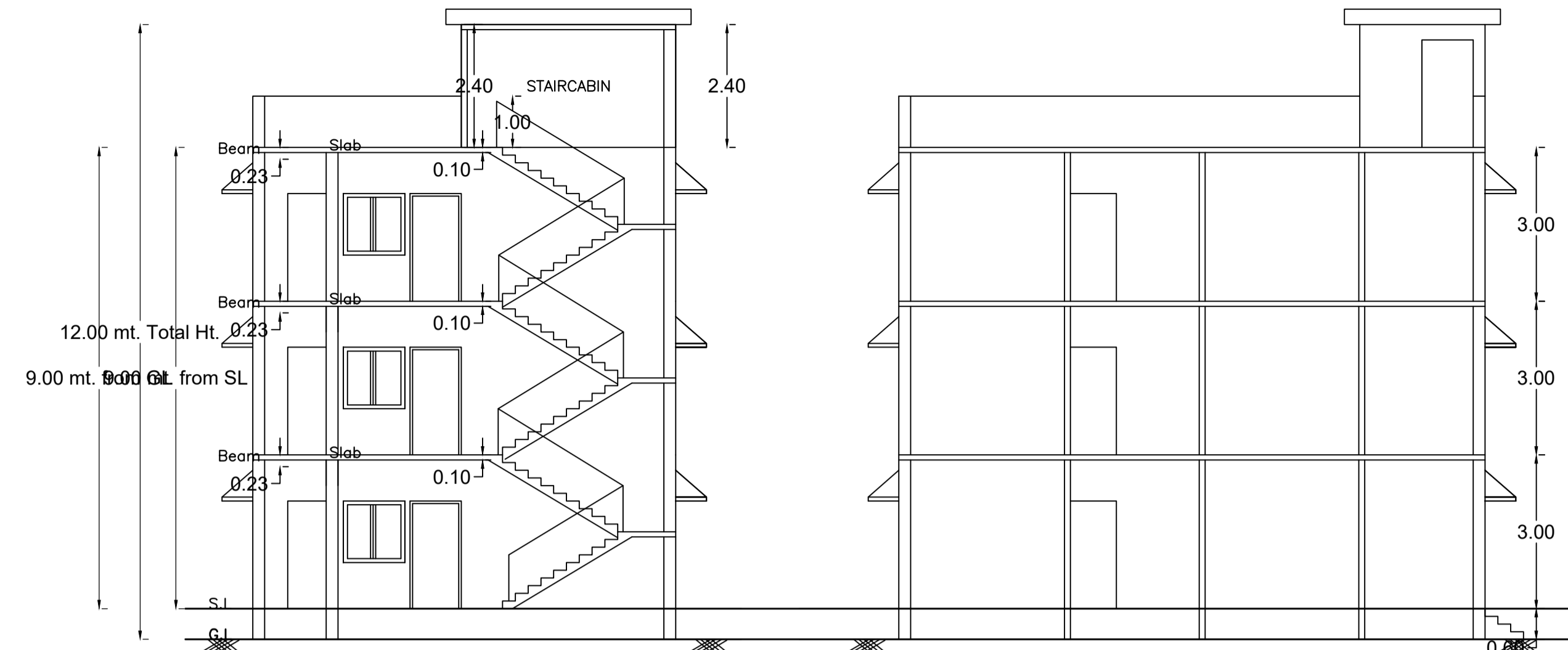
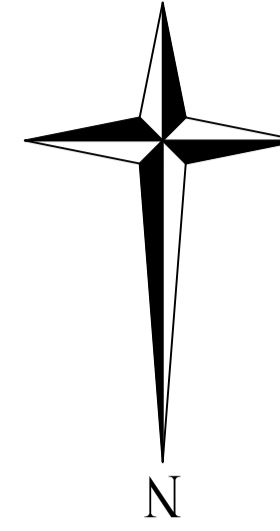

AREA STATEMENT CHAS MUNICIPAL CORPORATION	VERSION NO: 1.0.72	SQ. MT.
PROJECT DETAIL:	VERSION DATE: 16/10/2020	
Region: JHARKHAND URBAN LOCAL BODIES	Plot Use: Residential	
District: BOKARO	Plot SubUse: Bungalow/ Dwelling / Non Apartment	
Authority: CHAS MUNICIPAL CORPORATION	PlotNearbyReligiousStructure: NA	
Inward No: CMC/BP/0134/W07/2024	PlotSubPlot No: 2486	
Application Type: General Proposal	North: Road Width - 6.10 M ROAD	
Project Type: Building Permission	South: Plot No. - C MARK LAND	
Nature of Development: New	East: Plot No. - PART OF PLOT	
Location of Development Area: Old Area	West: Plot No. - B MARK LAND	
AREA DETAILS:		
AREA OF PLOT (Minimum)	(A)	166.93
NET AREA OF PLOT(Gross Plot Area - Deduction from Gross Plot area)	(A-Deductions)	166.93
Deduction for Balance Plot Area(from Gross Plot Area)		
Common Plot		18.41
Total		18.41
BALANCE AREA OF PLOT(Net Plot Area - Recreational/Amenity space)	(A-Deductions)	148.52
PLOT AREA FOR COVERAGE(Net Plot Area)	(A-Deductions)	166.93
Plot Area for FAR (Net Plot Area + RoadWidening Area)	(A-Deductions)	166.93
COVERAGE CHECK		
Permissible Coverage area (70.00 %)		116.85
Proposed Coverage Area (56.51 %)		94.34
Total Prop. Coverage Area (56.51 %)		94.34
Balance coverage area (13.48 %)		22.51
FAR CHECK		
Perm. FAR Area (2.500)		417.32
Total Perm. FAR area		417.32
Residential FAR		283.02
Proposed FAR Area		283.02
Total Proposed FAR Area		283.02
Consumed FAR (Factor)		1.70
Balance FAR Area		134.30
BUILT UP AREA CHECK		
Total Proposed BuiltUp Area		283.02
ARCHITECT (Regd)	Deepak Kumar	
ENGINEER (Regd)		
SUPERVISOR (Regd)	PUSHPA DEVI	
OWNER (Regd)		
DEVELOPMENT AUTHORITY		LOCAL BODY

COLOR INDEX	
PLOT BOUNDARY	Black
ABUTTING ROAD	Red
PROPOSED CONSTRUCTION	Green
COMMON PLOT	Yellow
ROAD WIDENING AREA	Blue
EXISTING (To be retained)	Light Blue
EXISTING (To be demolished)	Dark Blue

Building :A (RESIDENTIAL)					
Floor Name	Total Built Up Area (Sq.mt.)	Proposed FAR Area (Sq.mt.) Resi.	Total FAR Area (Sq.mt.)	Total Consumed Additional FAR Area (Sq.mt.)	Tnmt (No.)
Ground Floor	94.34	94.34	94.34	94.34	01
First Floor	94.34	94.34	94.34	94.34	00
Second Floor	94.34	94.34	94.34	94.34	00
Terrace Floor	0.00	0.00	0.00	0.00	00
Total :	283.02	283.02	283.02	283.02	01
Total Number of Same Buildings :	1				
Total :	283.02	283.02	283.02	283.02	01

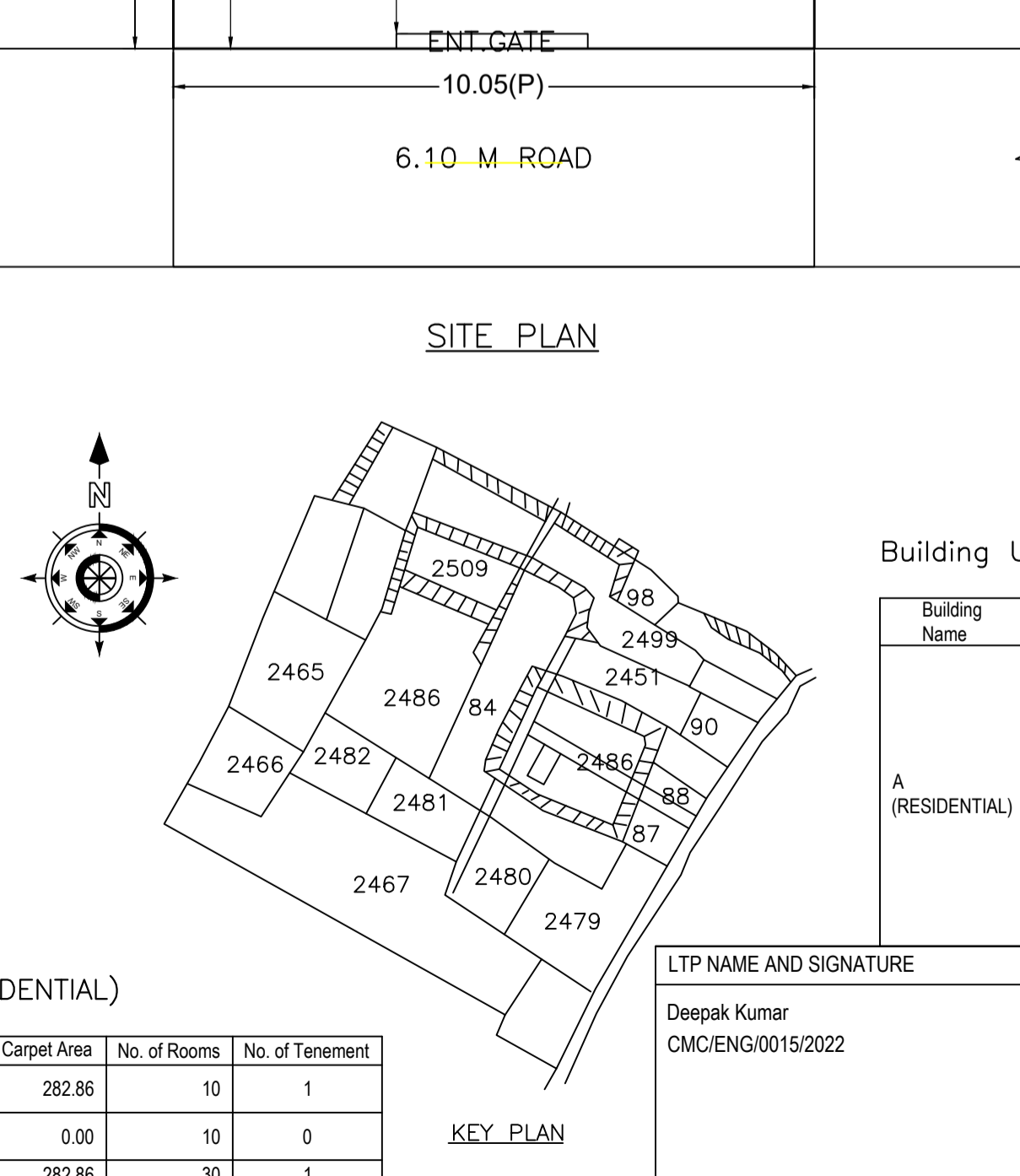
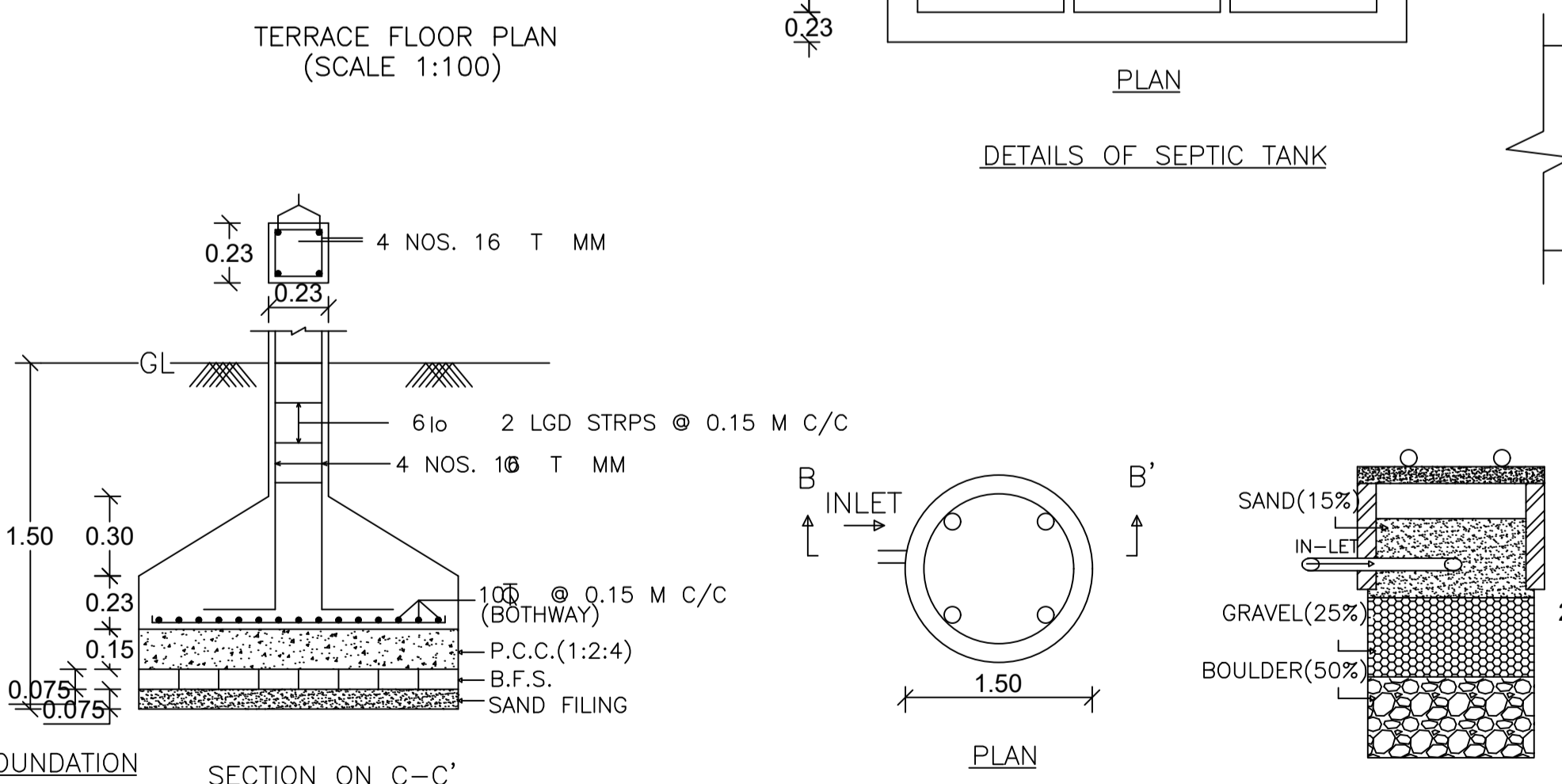
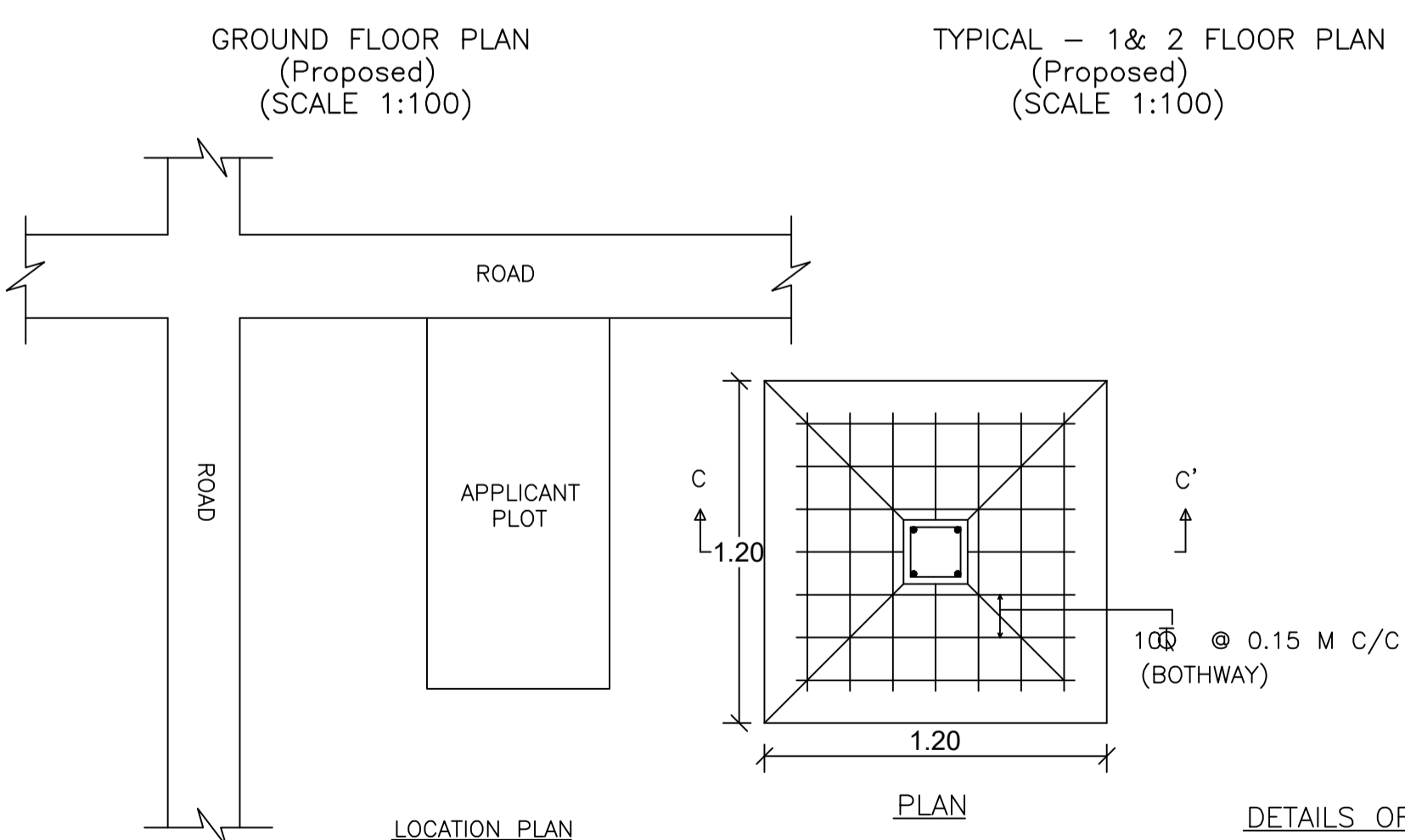

SCHEDULE OF DOOR:

BUILDING NAME	NAME	LENGTH	HEIGHT	NOS
A (RESIDENTIAL)	D2	0.75	2.10	09
A (RESIDENTIAL)	D1	0.90	2.10	03
A (RESIDENTIAL)	D	1.00	2.10	15

Buildingwise Floor FAR Details

Floor Name	Building Name A (RESIDENTIAL)		Total	
	Proposed Built Up Area (Sq.mt.)	Proposed FAR Area (Sq.mt.)	Total Proposed Built Up Area (Sq.mt.)	Total FAR Area (Sq.mt.)
Ground Floor	94.34	94.34	94.34	94.34
First Floor	94.34	94.34	94.34	94.34
Second Floor	94.34	94.34	94.34	94.34
Terrace Floor	0.00	0.00	0.00	0.00
Total :	283.02	283.02	283.02	283.02

FAR & Tenement Details (Table 4c-1)

Building	No. of Same Bldg	Total Built Up Area (Sq.mt.)	Proposed FAR Area (Sq.mt.) Resi.	Total FAR Area (Sq.mt.)	Total Consumed Additional FAR Area (Sq.mt.)	Tnmt (No.)	UnitBUA Table for Building :A (RESIDENTIAL)						
							FLOOR	Name	UnitBUA Type	UnitBUA Area	Carpet Area	No. of Rooms	No. of Tenement
A (RESIDENTIAL)	1	283.02	283.02	283.02	283.02	01	GROUND FLOOR PLAN	SPLIT 1	FLAT	283.02	282.86	10	1
							TYPICAL - 1& 2 FLOOR PLAN	SPLIT 1	FLAT	0.00	0.00	10	0
							TERRACE FLOOR PLAN	-	-	0.00	0.00	30	1
Grand Total :													

Building USE/SUBUSE Details

Building Name	Building Use	Building SubUse	Building Structure	Floor Name	Floor Use	Floor SubUse	FAR Name	FAR Use	FAR SubUse
A (RESIDENTIAL)	Residential	Bungalow/ Dwelling / Non Apartment	Non-Highrise	GROUND FLOOR PLAN	Residential	Bungalow/ Dwelling / Non Apartment	RESIFAR	Residential	Bungalow/ Dwelling / Non Apartment
				TYPICAL - 1& 2 FLOOR PLAN	Residential	Bungalow/ Dwelling / Non Apartment	RESIFAR	Residential	Bungalow/ Dwelling / Non Apartment
				TERRACE FLOOR PLAN	Residential	Bungalow/ Dwelling / Non Apartment	-	-	-