

Proposal Basic Information

Proposal File No.	CMC/BP/0136/W06/2024
Owner Name	ARJUN MAHATO
Khata No	127
Plot No	260,261
Village Name	Bhawaniapur
Use	Residential
SubUse	Bungalow/ Dwelling / Non Apartment

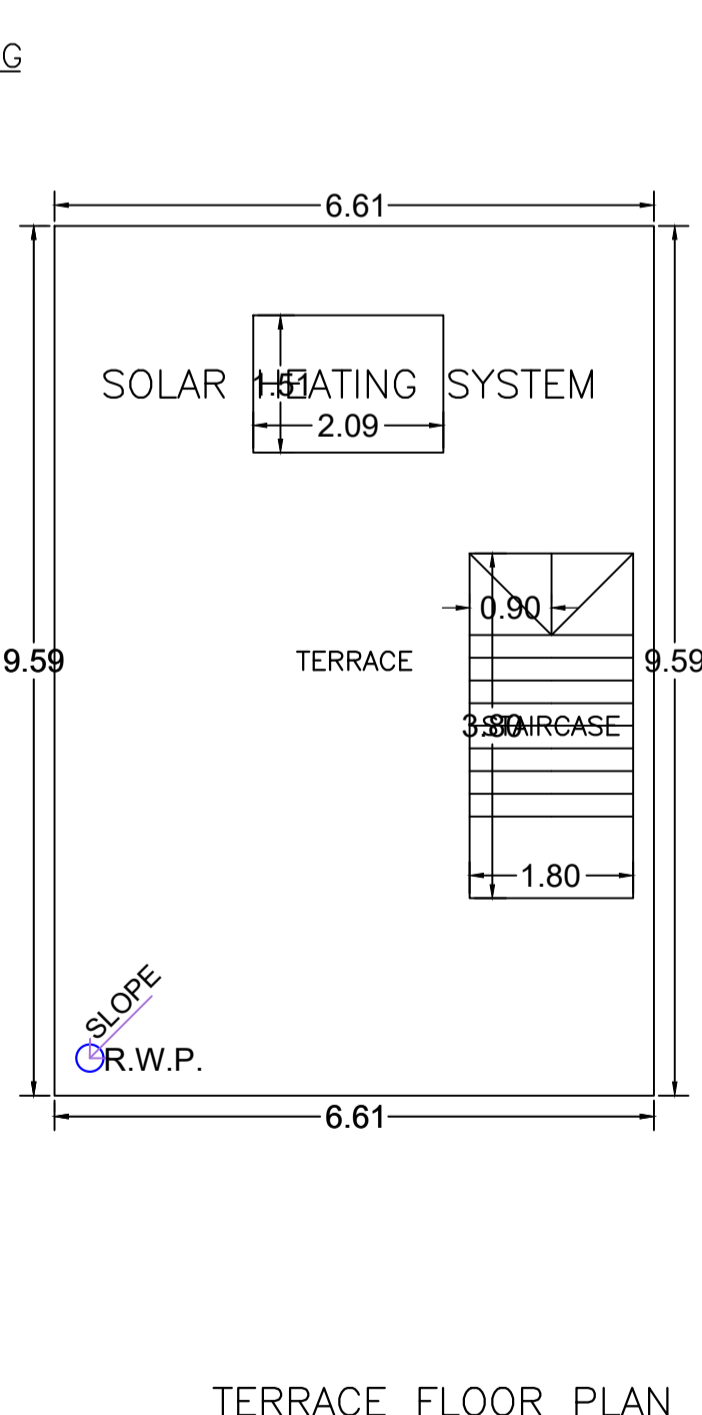

DETAILS OF WATER HARVESTING

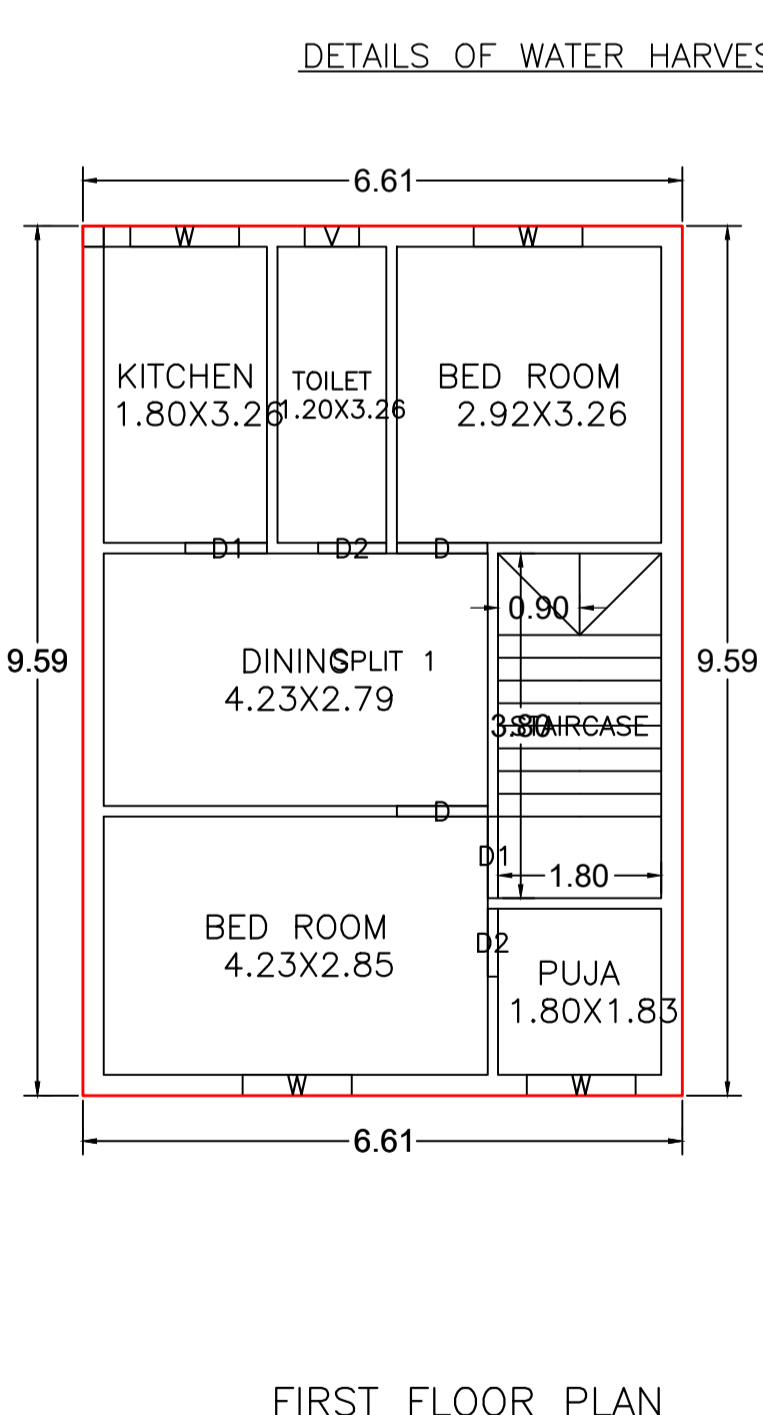
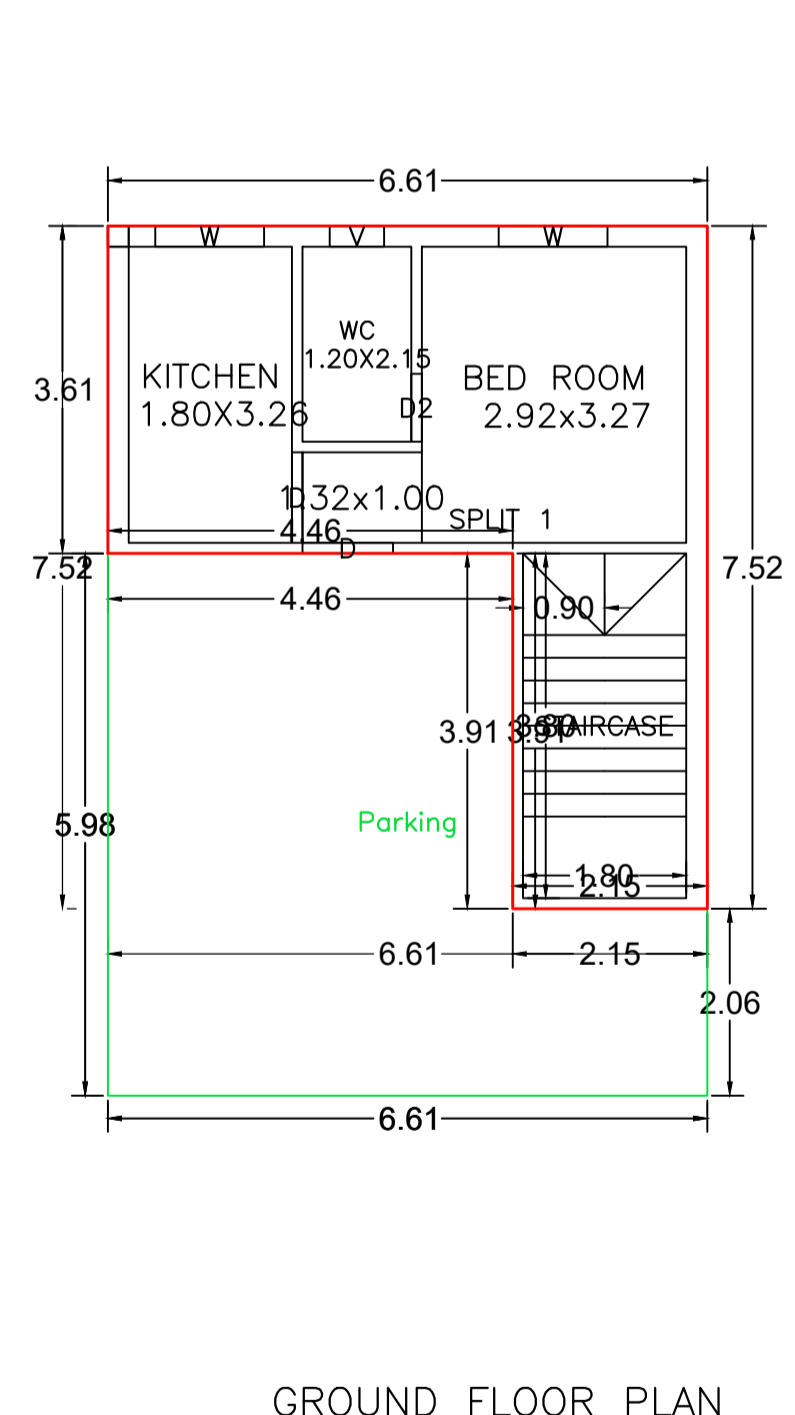
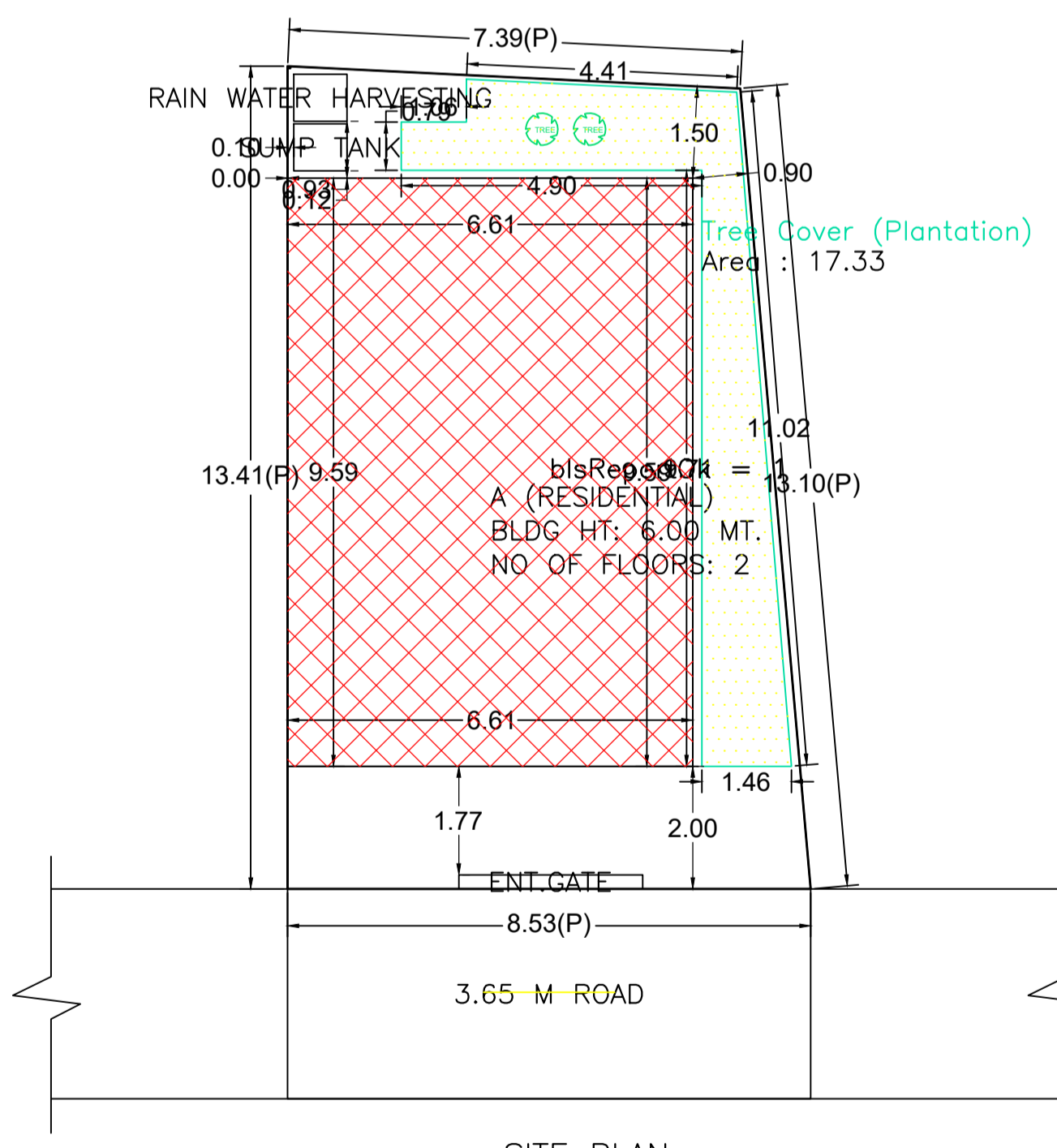
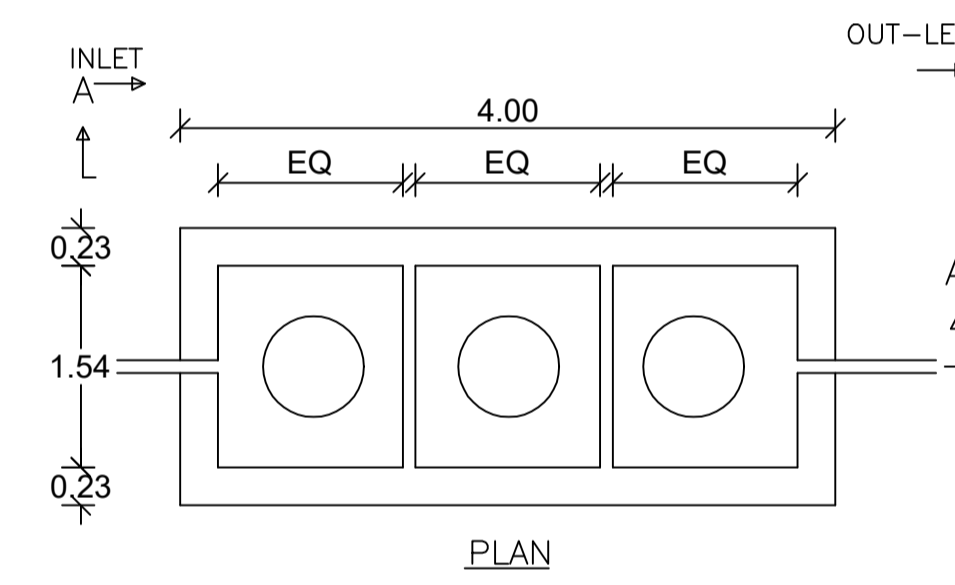
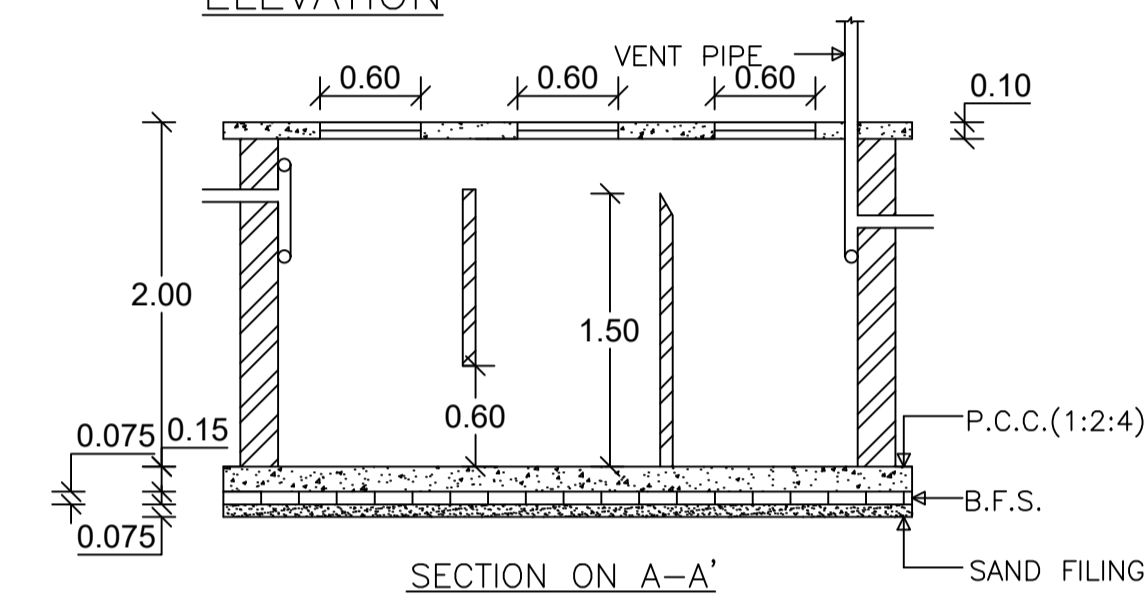
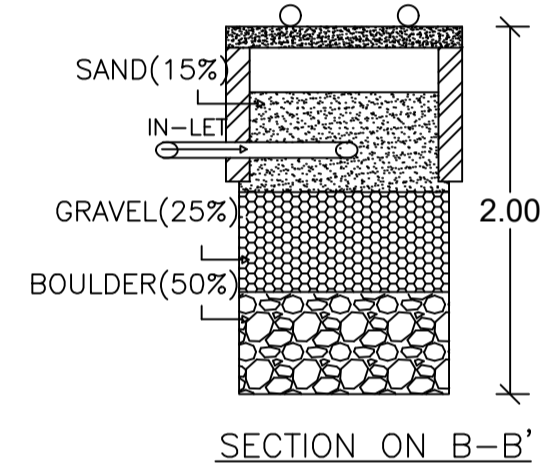
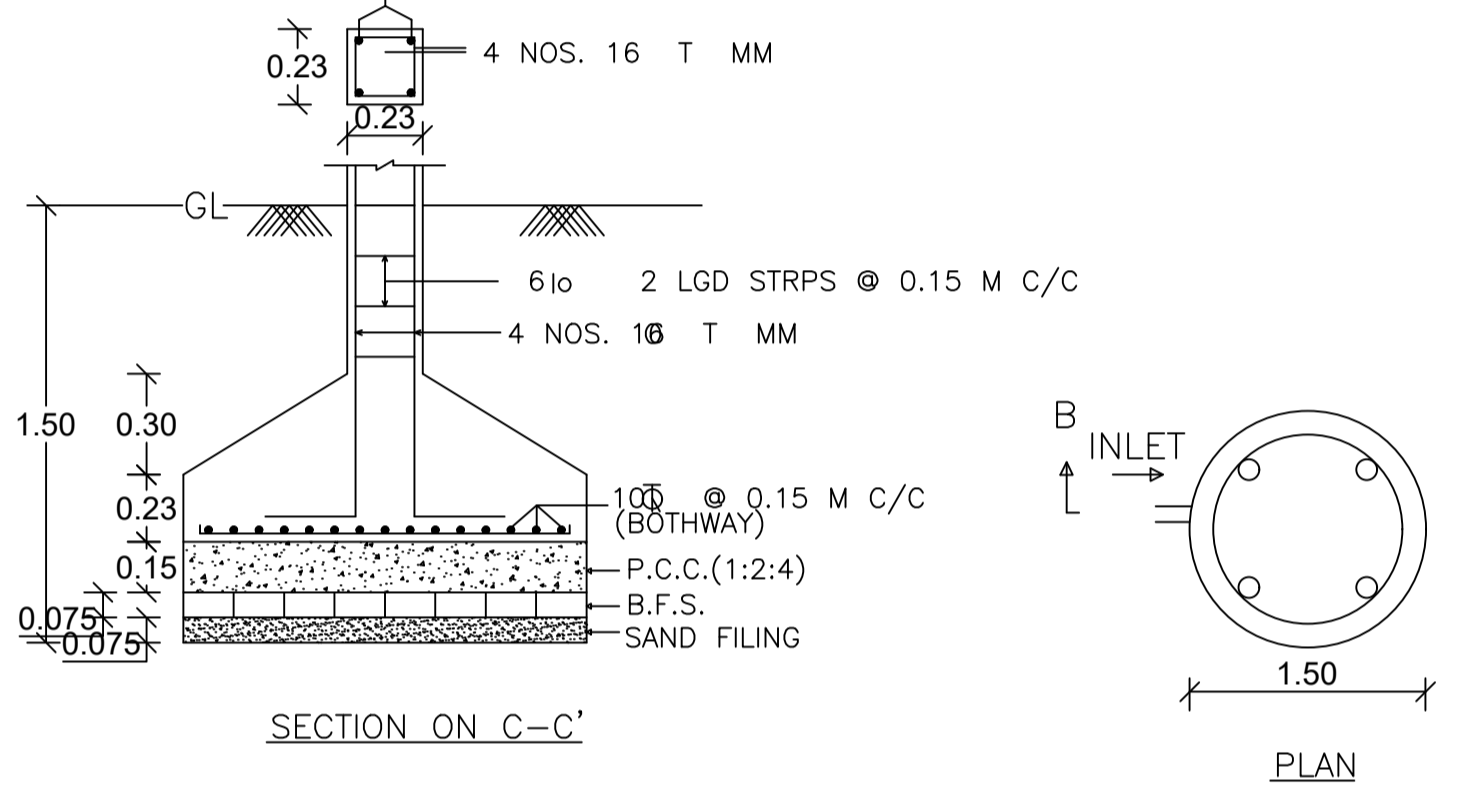
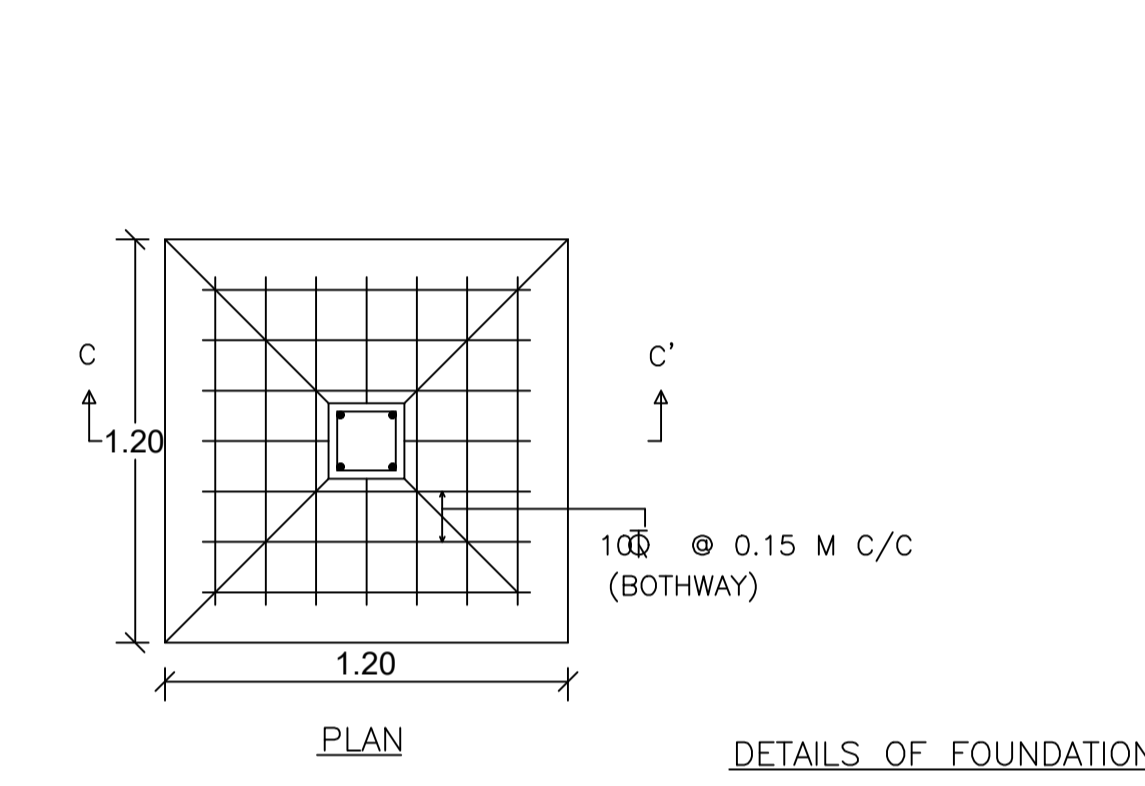
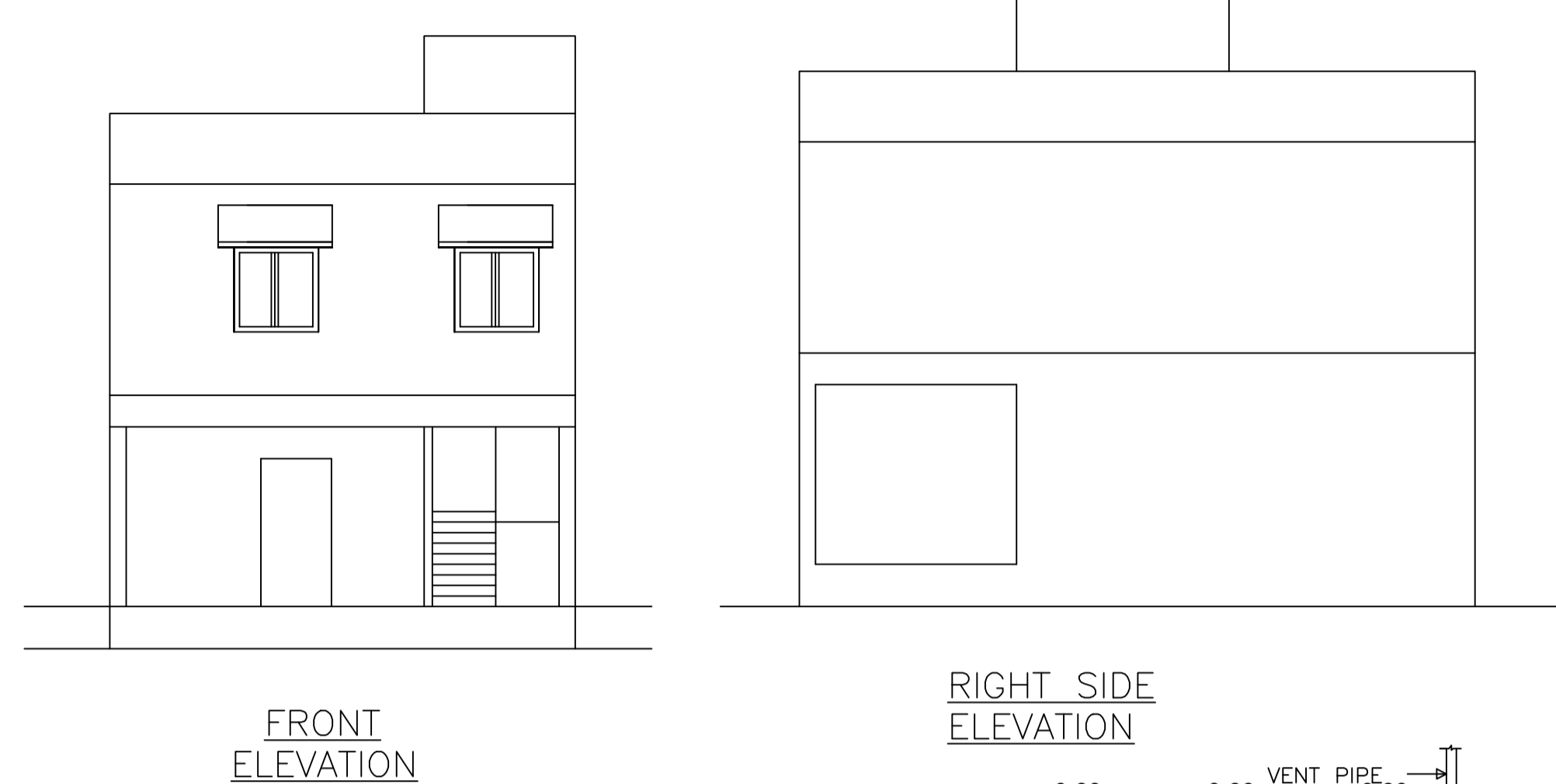
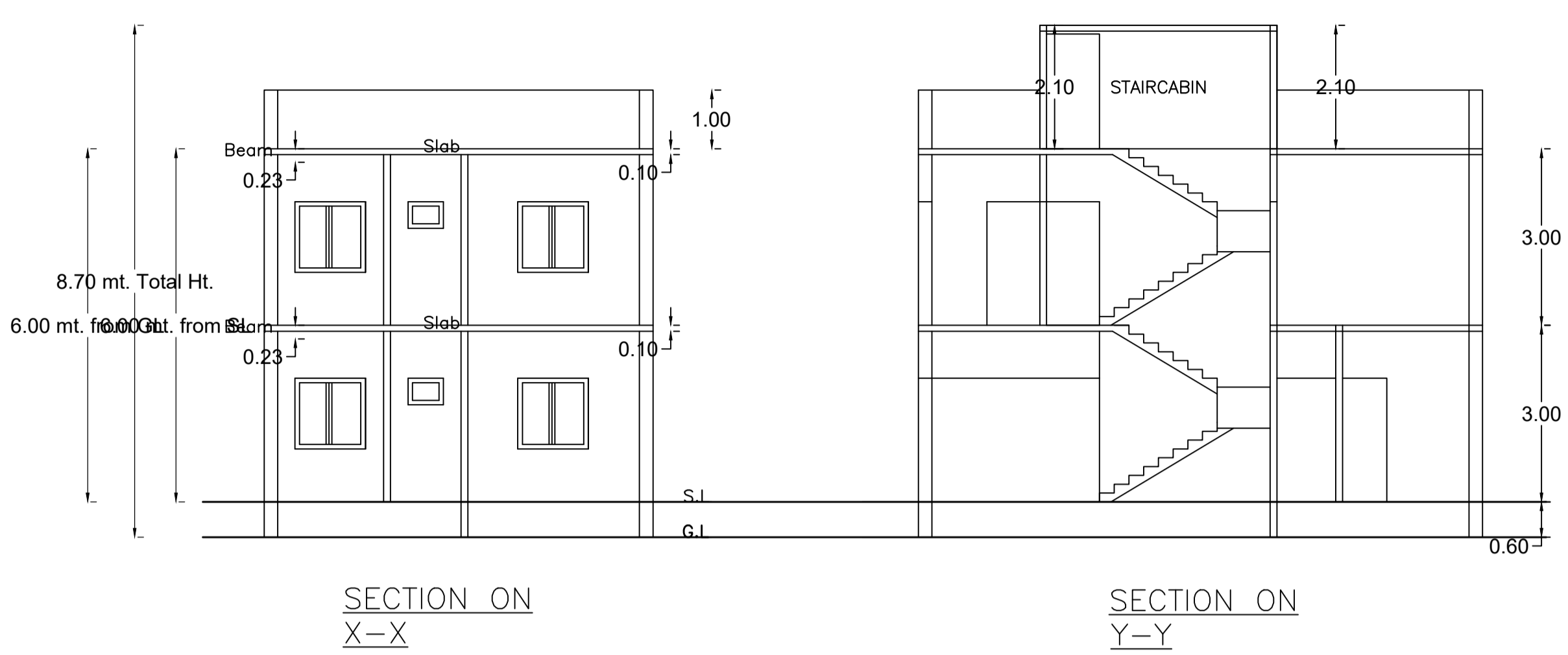
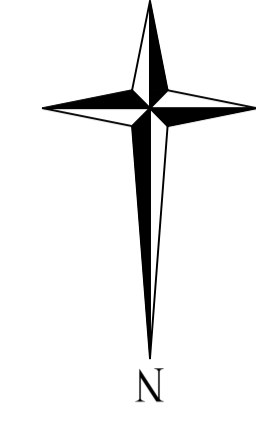
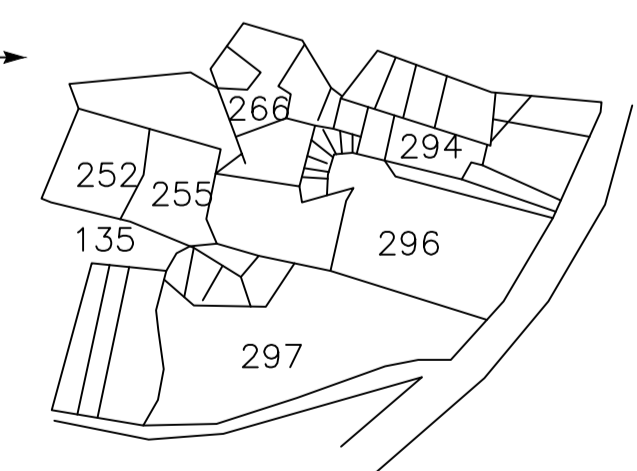
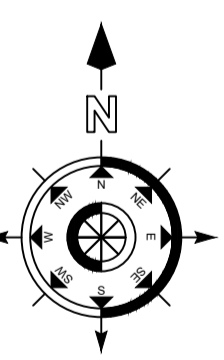

FAR & Tenement Details (Table 4c-1)

Building	No. of Same Bldg	Total Built Up Area (Sq.mt.)	Deductions (Area in Sq.mt.)	Proposed FAR Area (Sq.mt.)	Total FAR Area (Sq.mt.)	Total Consumed Additional FAR Area (Sq.mt.)	Tnmt (No.)
A (RESIDENTIAL)	1	126.66	31.09	95.57	95.57	95.57	01
Grand Total :	1	126.66	31.09	95.57	95.57	95.57	01

SCHEDULE OF DOOR:

BUILDING NAME	NAME	LENGTH	HEIGHT	NOS
A (RESIDENTIAL)	D2	0.75	2.10	03
A (RESIDENTIAL)	D1	0.90	2.10	02
A (RESIDENTIAL)	D	1.00	2.10	04

SCHEDULE OF WINDOW/VENTILATION:

BUILDING NAME	NAME	LENGTH	HEIGHT	NOS
A (RESIDENTIAL)	V	0.60	1.20	02
A (RESIDENTIAL)	W	1.20	1.20	06

Building USE/SUBUSE Details

Building Name	Building Use	Building SubUse	Building Structure	Floor Name	Floor Use	FAR Name	FAR Use	FAR SubUse
A (RESIDENTIAL)	Residential	Bungalow/ Dwelling / Non Apartment	Non-Highrise	GROUND FLOOR PLAN	Residential	RESIFAR	Residential	Bungalow/ Dwelling / Non Apartment
				FIRST FLOOR PLAN	Residential	RESIFAR	Residential	Bungalow/ Dwelling / Non Apartment
				TERRACE FLOOR PLAN	Residential	-	-	-

Buildingwise Floor FAR Details

Floor Name	Building Name A (RESIDENTIAL)		Total		Tnmt (No.)
	Proposed Built Up Area (Sq.mt.)	Proposed FAR Area (Sq.mt.)	Total Proposed Built Up Area (Sq.mt.)	Total FAR Area (Sq.mt.)	
Ground Floor	63.33	31.09	63.33	31.09	01
First Floor	63.33	0.00	63.33	0.00	00
Terrace Floor	0.00	0.00	0.00	0.00	00
Total :	126.66	31.09	126.66	31.09	01

UnitBUA Table for Building :A (RESIDENTIAL)

Floor Name	Building Name A (RESIDENTIAL)		Total		No. of Rooms	No. of Tenement
	Proposed Built Up Area (Sq.mt.)	Proposed FAR Area (Sq.mt.)	Total Proposed Built Up Area (Sq.mt.)	Total FAR Area (Sq.mt.)		
Ground Floor	63.33	32.24	63.33	32.24	3	1
First Floor	63.33	63.33	63.33	63.33	6	0
Terrace Floor	0.00	0.00	0.00	0.00	0	0
Total :	126.66	95.57	126.66	95.57	9	1

LTP NAME AND SIGNATURE RAVI KUMAR CMC/DFTM/0024/2017	STRUCTURAL ENG'S NAME AND SIGNATURE	BUILDER NAME AND SIGNATURE	DIGITAL SIGNATURE
--	-------------------------------------	----------------------------	-------------------