

AREA STATEMENT	VERSION NO. : 1.0.17	
JAMSHEDPUR NAC	VERSION DATE: 16/10/2017	
PROJECT DETAIL:		
Region: JHARKHAND URBAN	Plot Use: Residential	
LOCAL BODIES	Plot SubUse: Residential Bldg/Apartment	
District: EAST SINGHBHUM	Plot SubPlot No. 3394	
Authority: JAMSHEDPUR NAC	Plot Neoby/Religious Structure: NA	
Inward No: JNAC/EP/075/W/11/2017	Plot/SubPlot No. 3394	
Application Type: General Proposal	North: Road Width - 12.19 MTR.	
Project Type: Building Permission	South: Road Width - ALLEY	
Nature of Development: New	East: -	
Location of Development Area: Old Area	West: Plot No. - H.NO. - 319	
AREA DETAILS:		
AREA OF PLOT (Minimum)	(A)	111.48
NET AREA OF PLOT (Gross Plot Area - Deduction from Gross Plot area)	(A-Deductions)	111.48
Deduction for Balance Plot Area (from Gross Plot Area)		
Common Plot		11.91
Total		11.91
BALANCE AREA OF PLOT (Net Plot Area - Recreational/Amenity space)	(A-Deductions)	99.57
PLOT AREA FOR COVERAGE (Net Plot Area)	(A-Deductions)	111.48
Plot Area for FAR (Net Plot Area + Road Widening Area)	(A-Deductions)	111.48
COVERAGE CHECK		
Permissible Coverage area (70.00 %)		78.04
Proposed Coverage Area (64.14 %)		71.50
Total Prop. Coverage Area (64.14 %)		71.50
Balance coverage area (5.87 %)		6.54
FAR CHECK		
Perm. FAR Area (2.50)		278.70
Total Perm. FAR area		278.70
Residential FAR		143.00
Proposed FAR Area		154.79
Total Proposed FAR Area		154.79
Consumed FAR (Factor)		1.39
Balance FAR Area		123.91
BUILT UP AREA CHECK		
Total Proposed BuiltUp Area		214.50
ARCHITECT (Regd)		MUKESH KUMAR
ENGINEER (Regd)		
SUPERVISOR (Regd)		
OWNER (Regd)		Smt. ASHAPURNA GHOSH
DEVELOPMENT AUTHORITY		LOCAL BODY

COLOR INDEX	
PLOT BOUNDARY	Black
ABUTTING ROAD	Red
PROPOSED CONSTRUCTION	Green
COMMON PLOT	Yellow
ROAD WIDENING AREA	Blue
EXISTING (To be retained)	Orange
EXISTING (To be demolished)	Purple

Floor Name	Building Name		Total	
	Proposed Built Up Area (Sq.mt.)	Proposed FAR Area (Sq.mt.)	Total Proposed Built Up Area (Sq.mt.)	Total FAR Area (Sq.mt.)
Ground Floor	71.50	11.80	71.50	11.80
First Floor	71.50	71.50	71.50	71.50
Second Floor	71.50	71.50	71.50	71.50
Terrace Floor	0.00	0.00	0.00	0.00
Total :	214.50	154.80	214.50	154.80

Building	No. of Same Bldg	Total Built Up Area (Sq.mt.)	Deductions (Area in Sq.mt.)		Proposed FAR Area (Sq.mt.)	Add Area In FAR (Sq.mt.)	Total FAR Area (Sq.mt.)	Total Consumed Additional FAR Area (Sq.mt.)	Trmt (No.)
			Parking	Resi.					
A (BUILDING)	1	214.50	59.70	143.00	11.80	154.80	154.80	02	
Grand Total :	1	214.50	59.70	143.00	11.80	154.80	154.80	02	

Floor Name	Total Built Up Area (Sq.mt.)	Deductions (Area in Sq.mt.)		Proposed FAR Area (Sq.mt.)	Add Area In FAR (Sq.mt.)	Total FAR Area (Sq.mt.)	Total Consumed Additional FAR Area (Sq.mt.)	Trmt (No.)
		Parking	Resi.					
Ground Floor	71.50	59.70	0.00	11.80	11.80	11.80	11.80	00
First Floor	71.50	0.00	71.50	0.00	71.50	71.50	71.50	01
Second Floor	71.50	0.00	71.50	0.00	71.50	71.50	71.50	01
Terrace Floor	0.00	0.00	0.00	0.00	0.00	0.00	0.00	00
Total :	214.50	59.70	143.00	11.80	154.80	154.80	154.80	02
Total Number of Same Buildings :	1							
Total :	214.50	59.70	143.00	11.80	154.80	154.80	154.80	02

Building Name	Building Use	Building SubUse	Building Structure
A (BUILDING)	Residential	Residential Bldg/Apartment	Non-Highrise

SITE PLAN

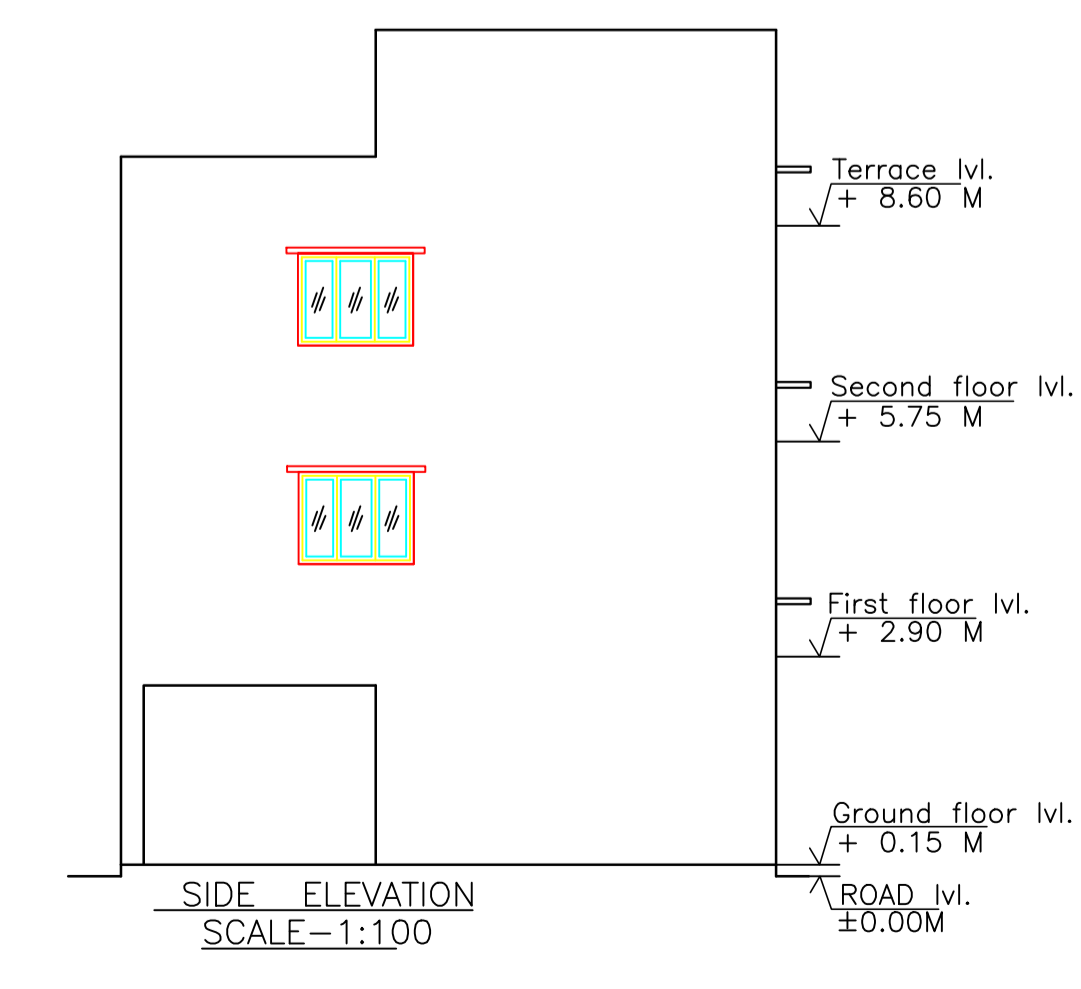
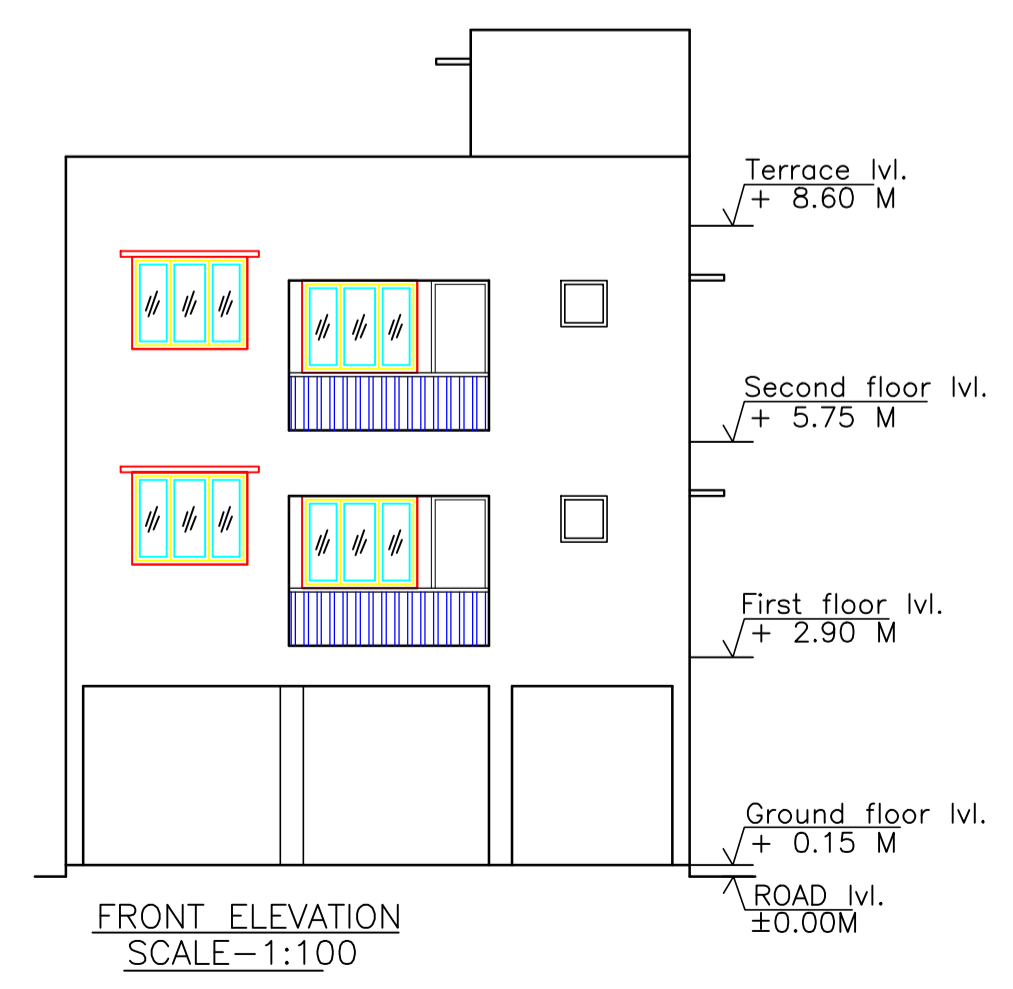
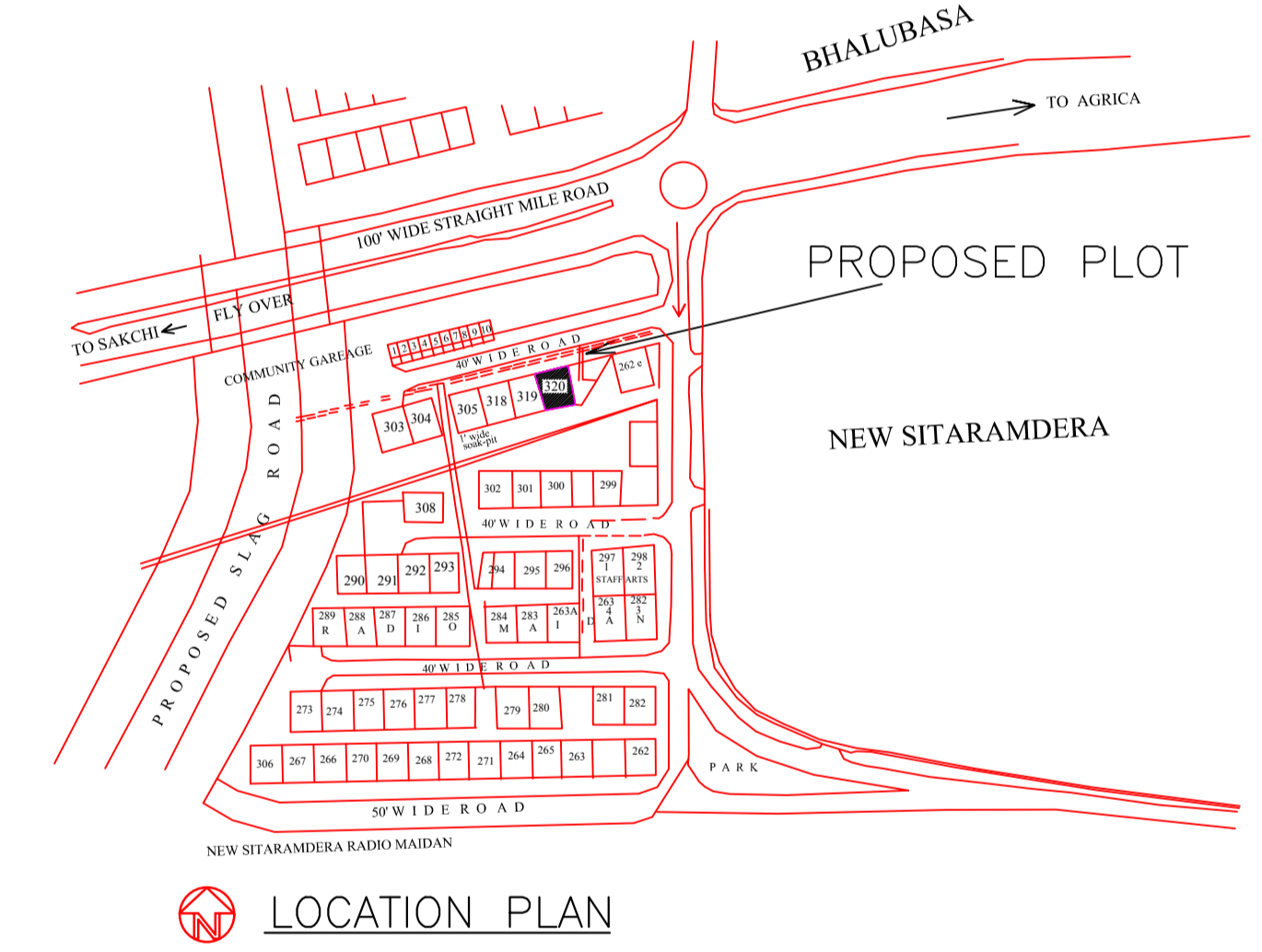
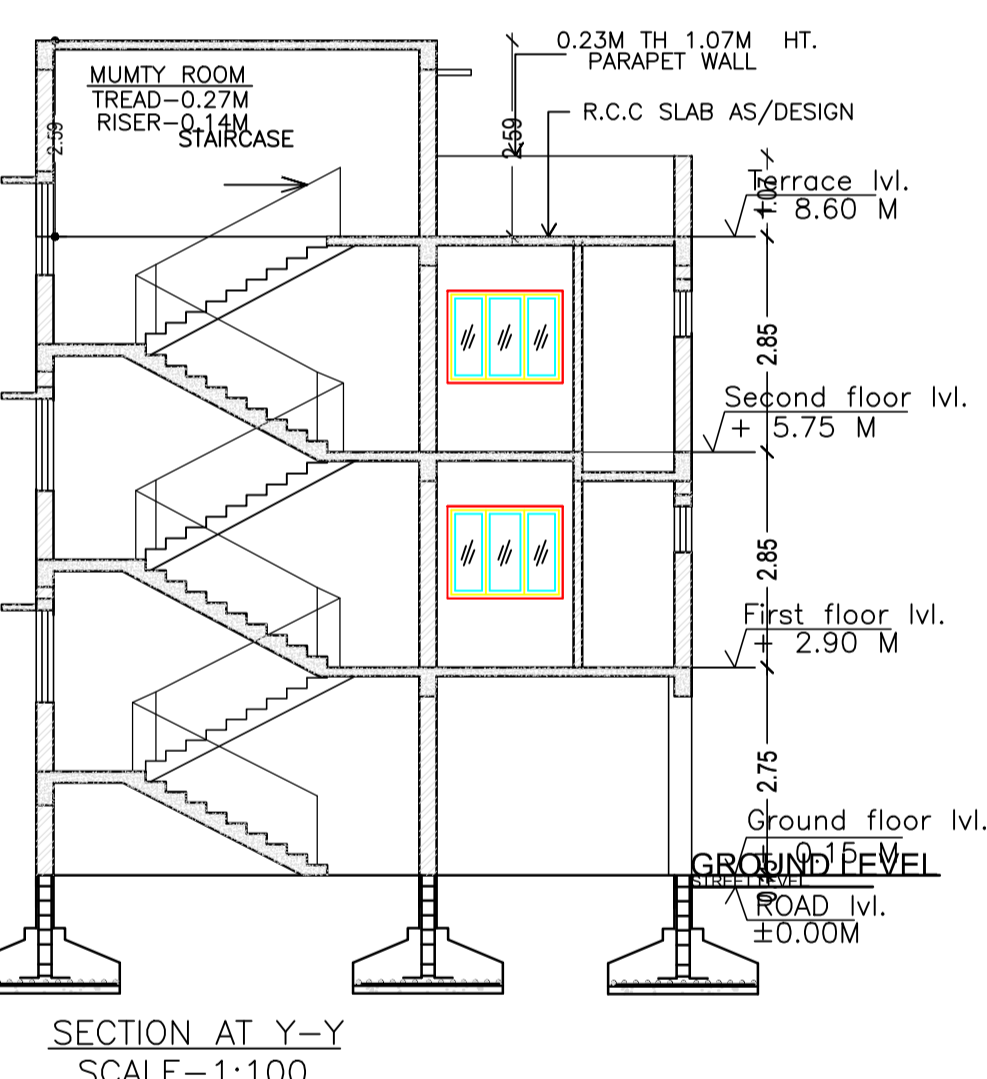
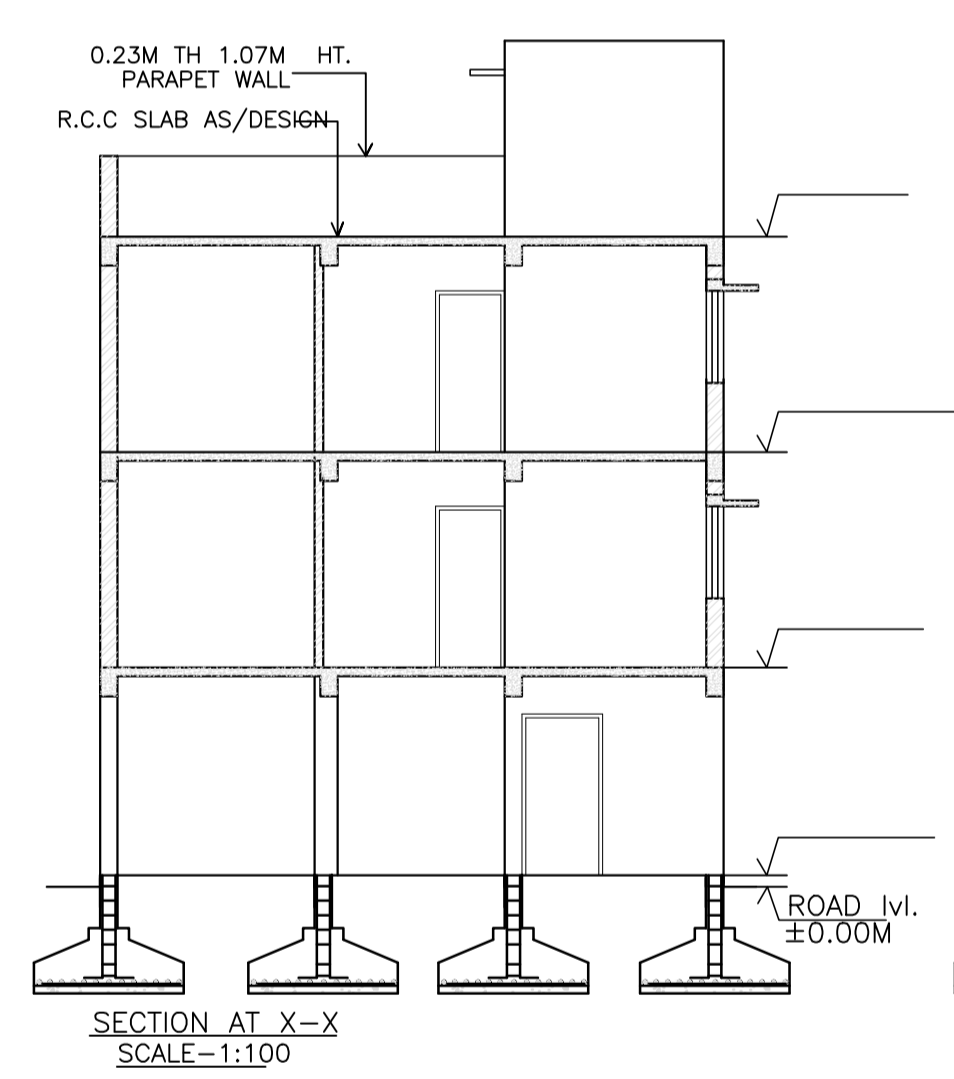
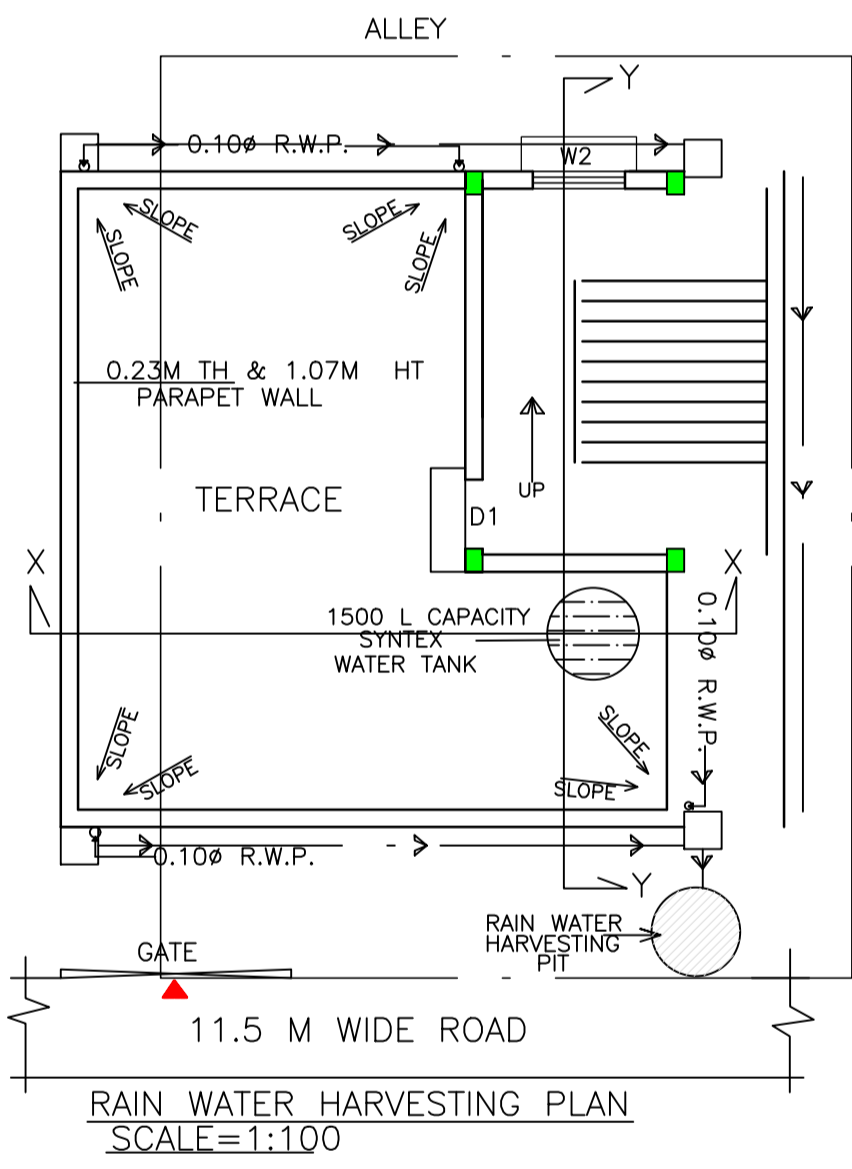

SCHEDULE OF DOOR:

BUILDING NAME	NAME	LENGTH	HEIGHT	NOS
A (BUILDING)	D2	0.76	2.10	04
A (BUILDING)	D1	0.91	2.10	06

SCHEDULE OF WINDOW/VENTILATION:

BUILDING NAME	NAME	LENGTH	HEIGHT	NOS
A (BUILDING)	V	0.61	0.61	02
A (BUILDING)	D	1.07	1.20	02
A (BUILDING)	W2	1.22	1.22	06
A (BUILDING)	W1	1.52	1.22	08

Required Parking (Table 7a)

Building Name	Type	SubUse	Area (Sq.mt.)	Units		Car		Visitors Car		TwoWheeler	
				Reqd.	Prop.	Reqd./Unit	Prop.	Reqd./Unit	Prop.	Reqd./Unit	Prop.
A (BUILDING)	Residential	Residential Bldg/Apartment	> 0	1	2.00	1.00	2	-	-	1	2
			> 0	1	2.00	-	-	-	-	-	-
			> 0	1	2.00	-	-	1	1	-	-
Total :			-	-	-	-	2	2	-	1	2

Parking Check (Table 7b)

Vehicle Type	Reqd.		Prop.	
	No.	Area	No.	Area
Car	2	25.00	2	25.00
Visitor's Car Parking	1	12.50	1	12.50
TwoWheeler	2	4.00	2	4.00
Other Parking	-	-	-	18.20
Total		41.50		59.70

LTP NAME AND SIGNATURE	STRUCTURAL ENG'S NAME AND SIGNATURE	BUILDER NAME AND SIGNATURE
MUKESH KUMAR JNAC/ENG/003/2017		