

SITE PLAN SCALE=1:100

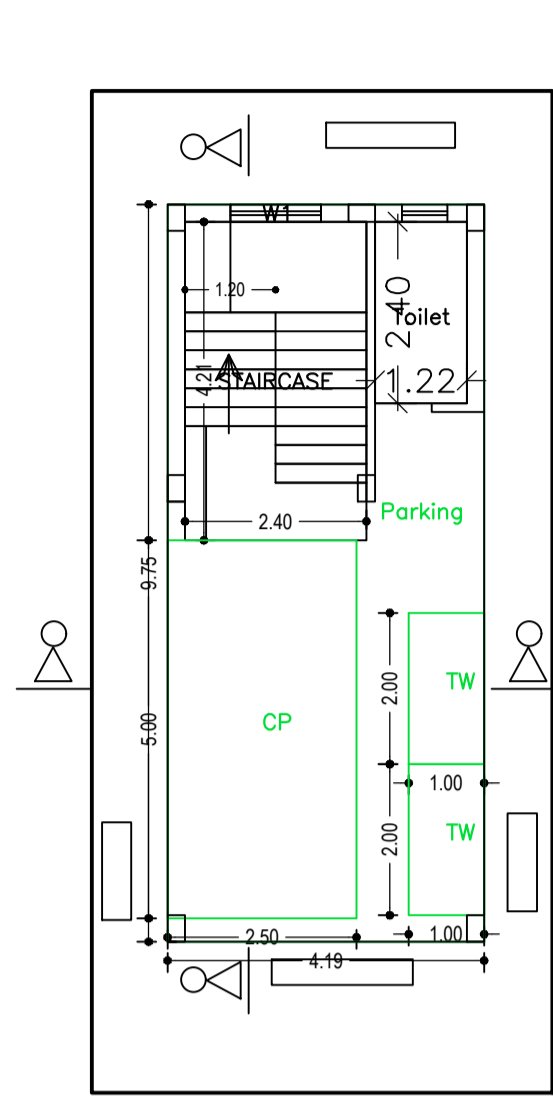

GROUND AND PARKING FLOOR PLAN (SCALE 1:100)

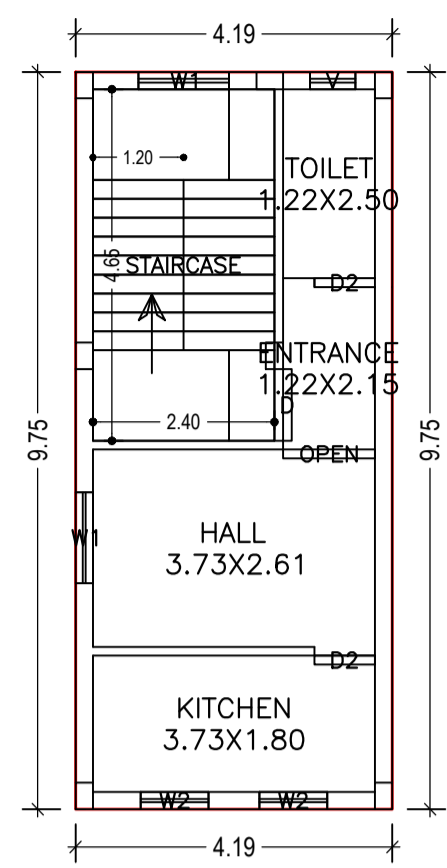

FIRST FLOOR PLAN (Proposed) (SCALE 1:100)

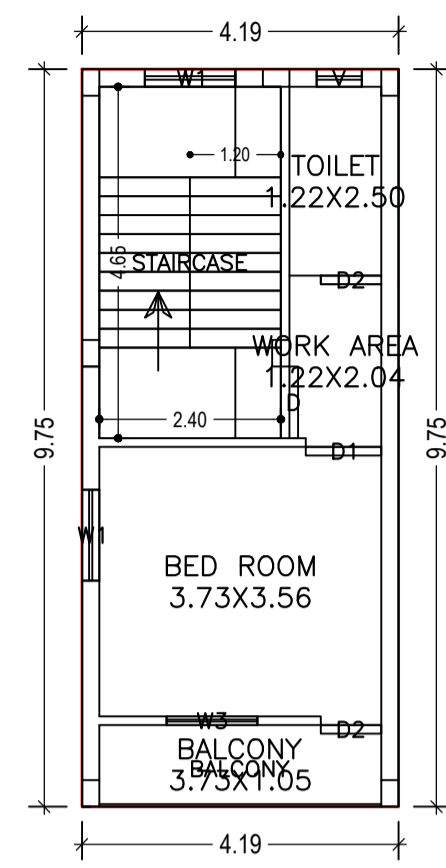

SECOND FLOOR PLAN (Proposed) (SCALE 1:100)

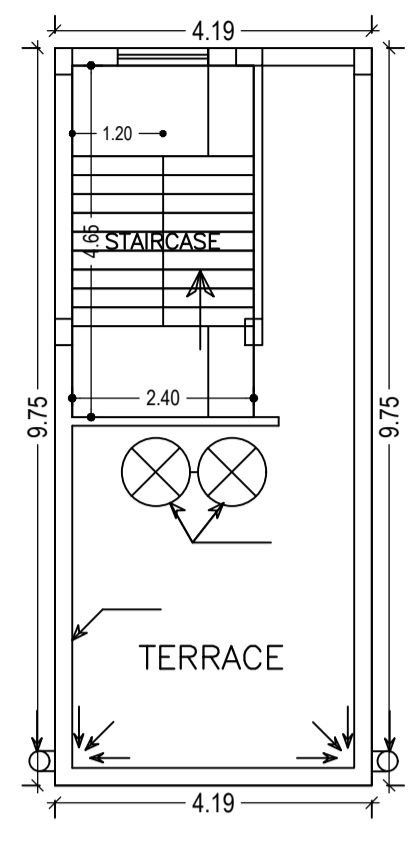

TERRACE FLOOR PLAN (SCALE 1:100)

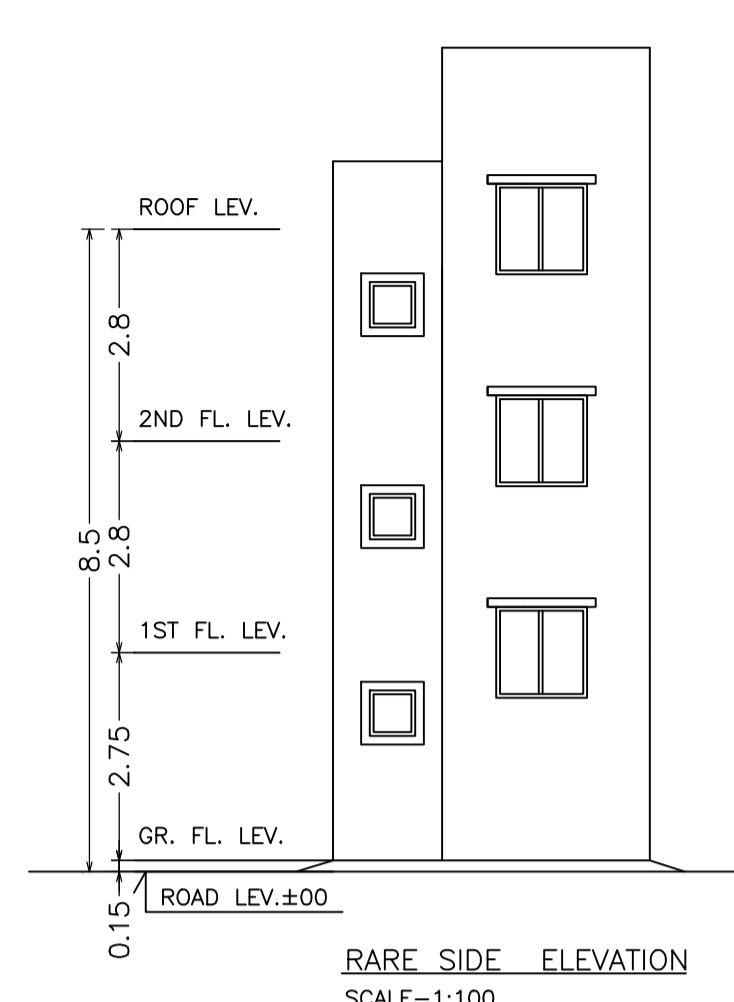

RARE SIDE ELEVATION SCALE=1:100

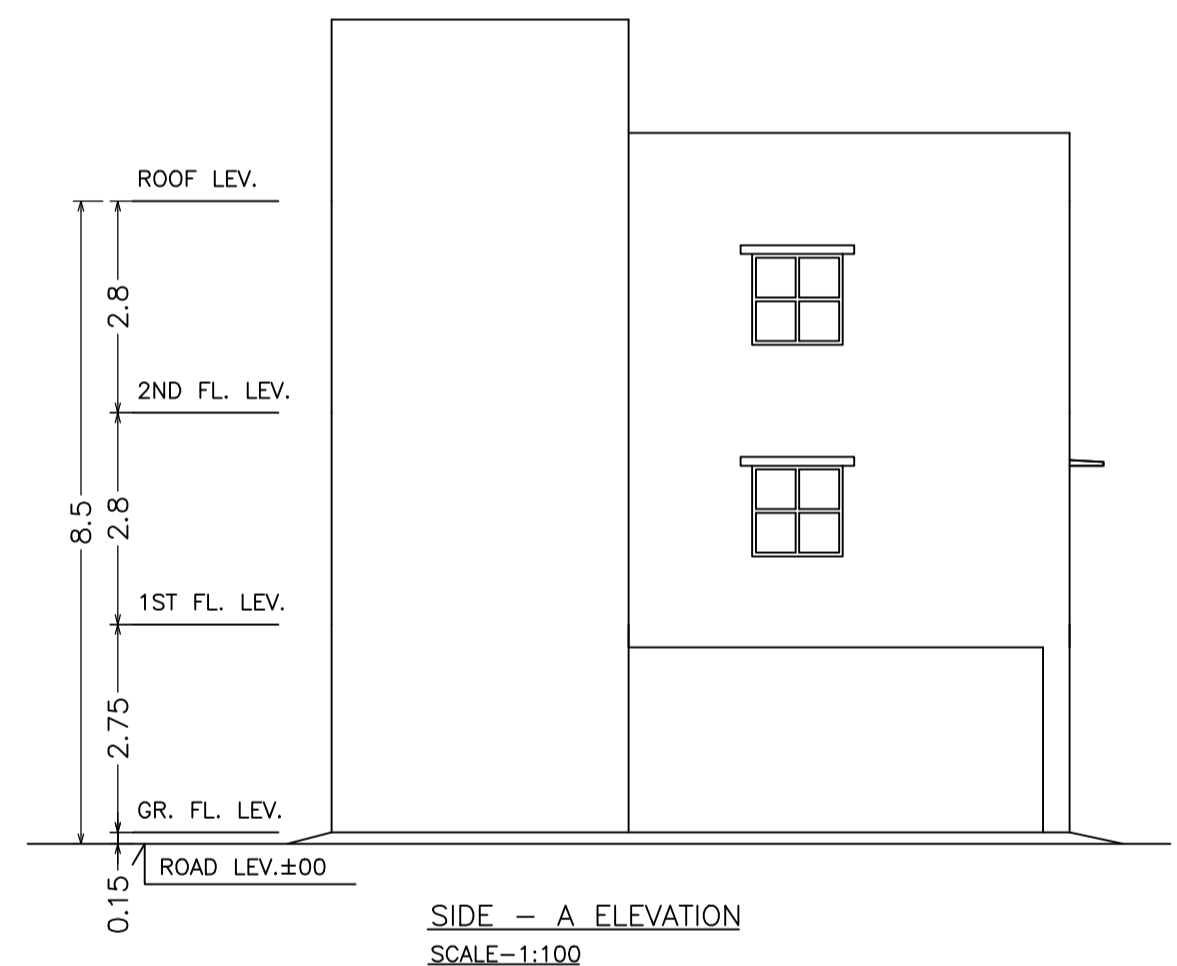

SIDE - A ELEVATION SCALE=1:100

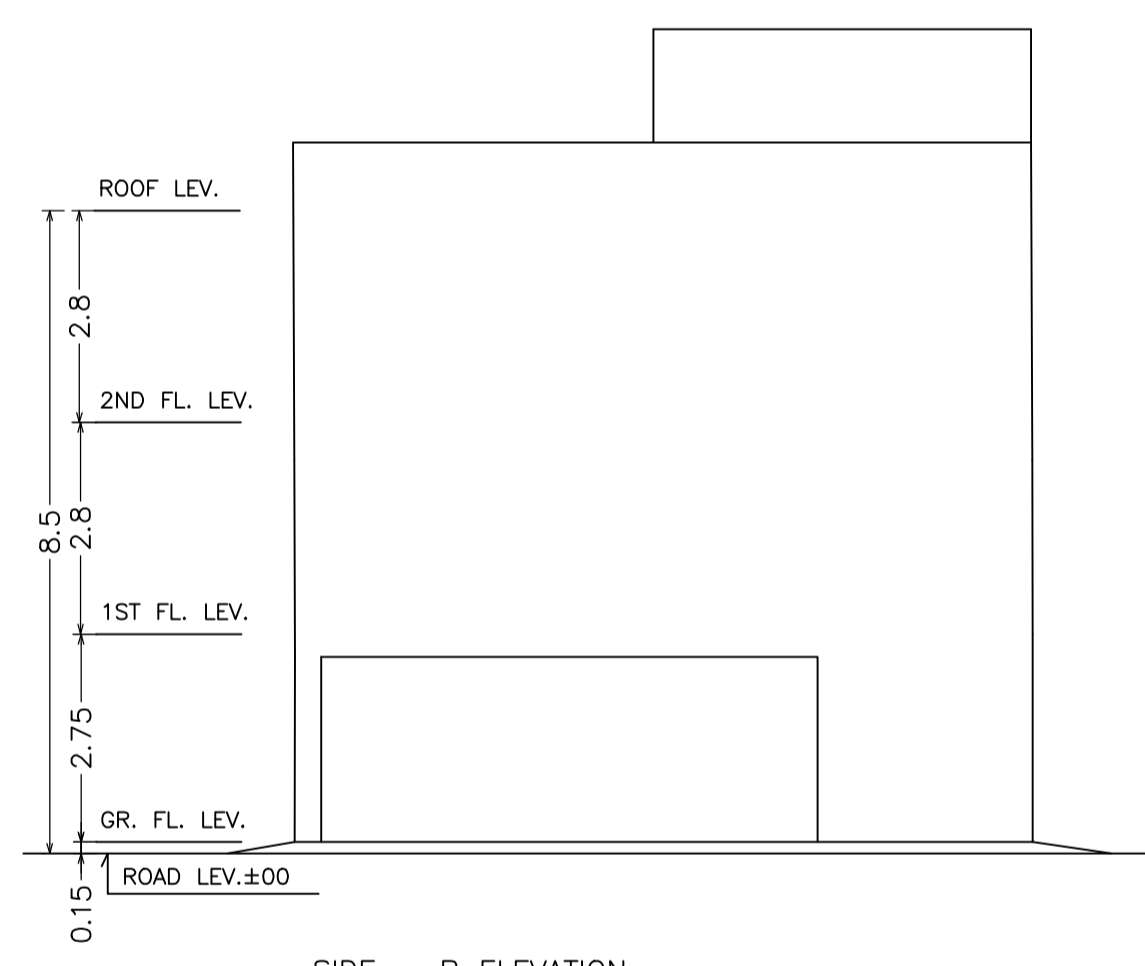

SIDE - B ELEVATION SCALE=1:100

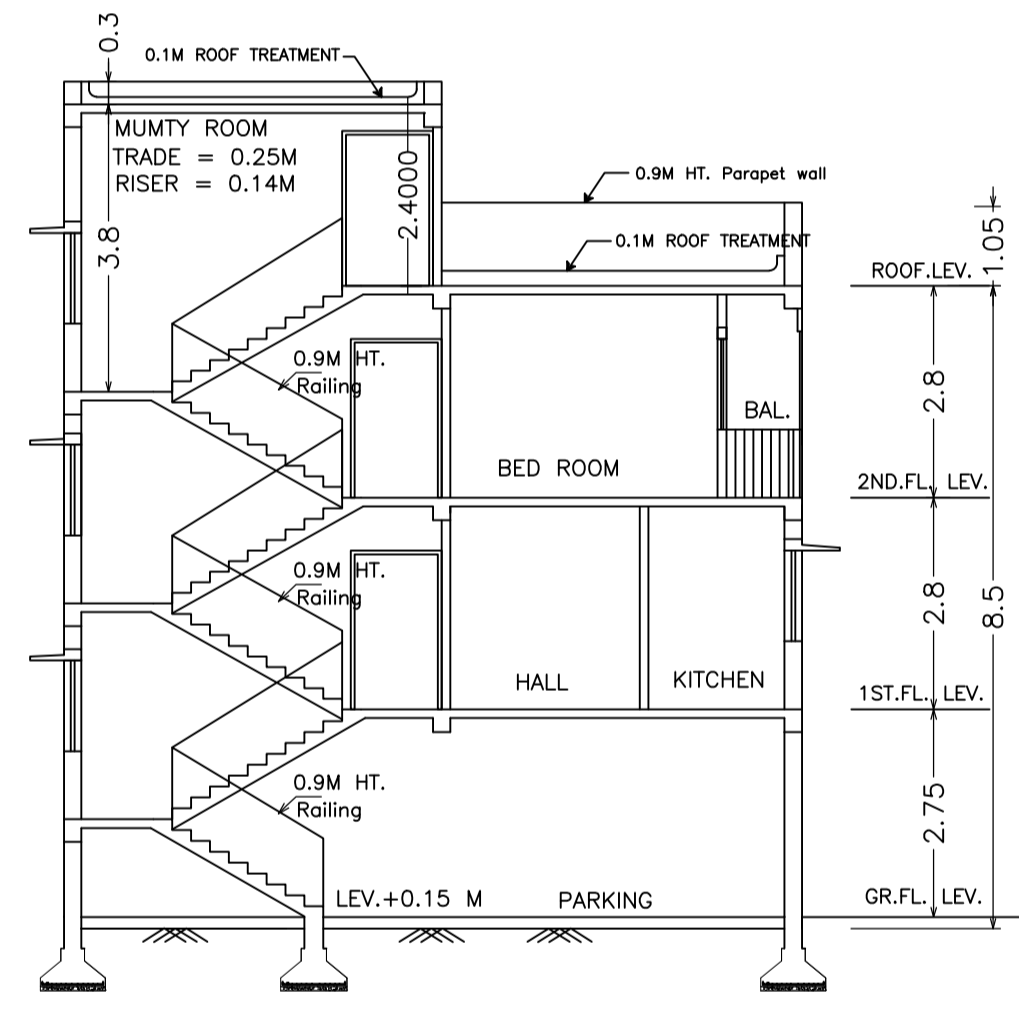

SECTION Y-Y SCALE=1:100

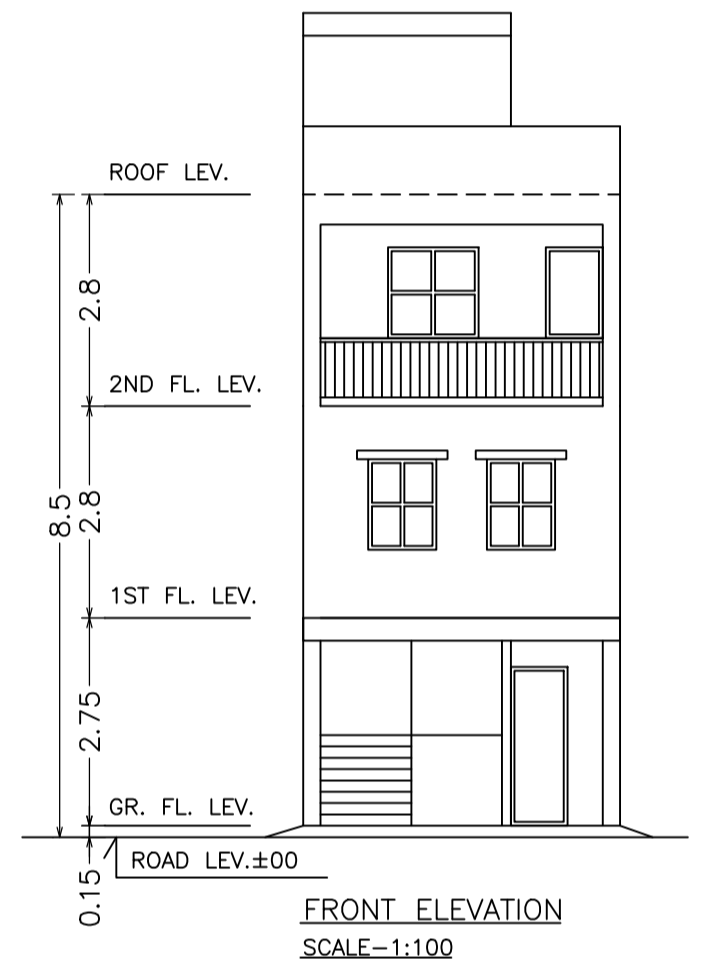

FRONT ELEVATION SCALE=1:100

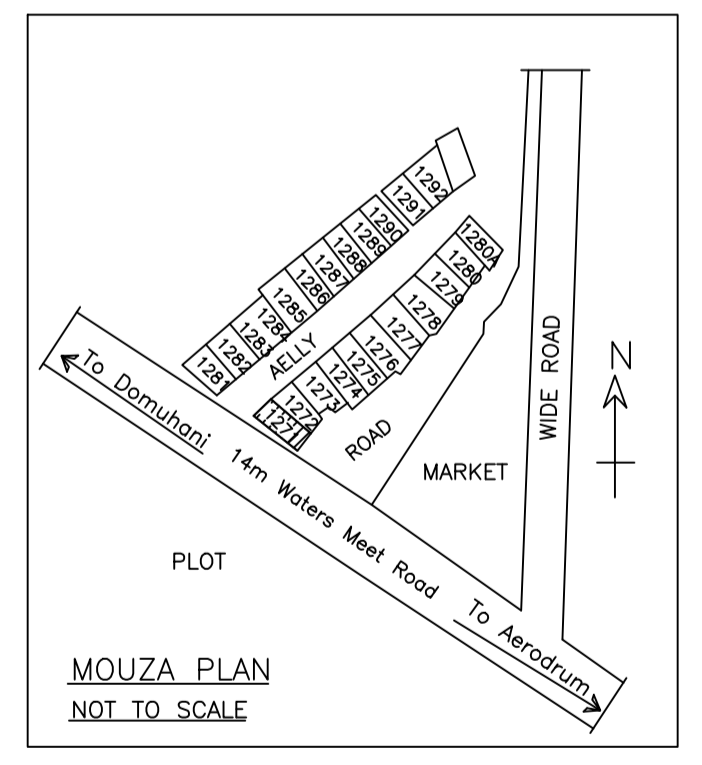

MOUZA PLAN NOT TO SCALE

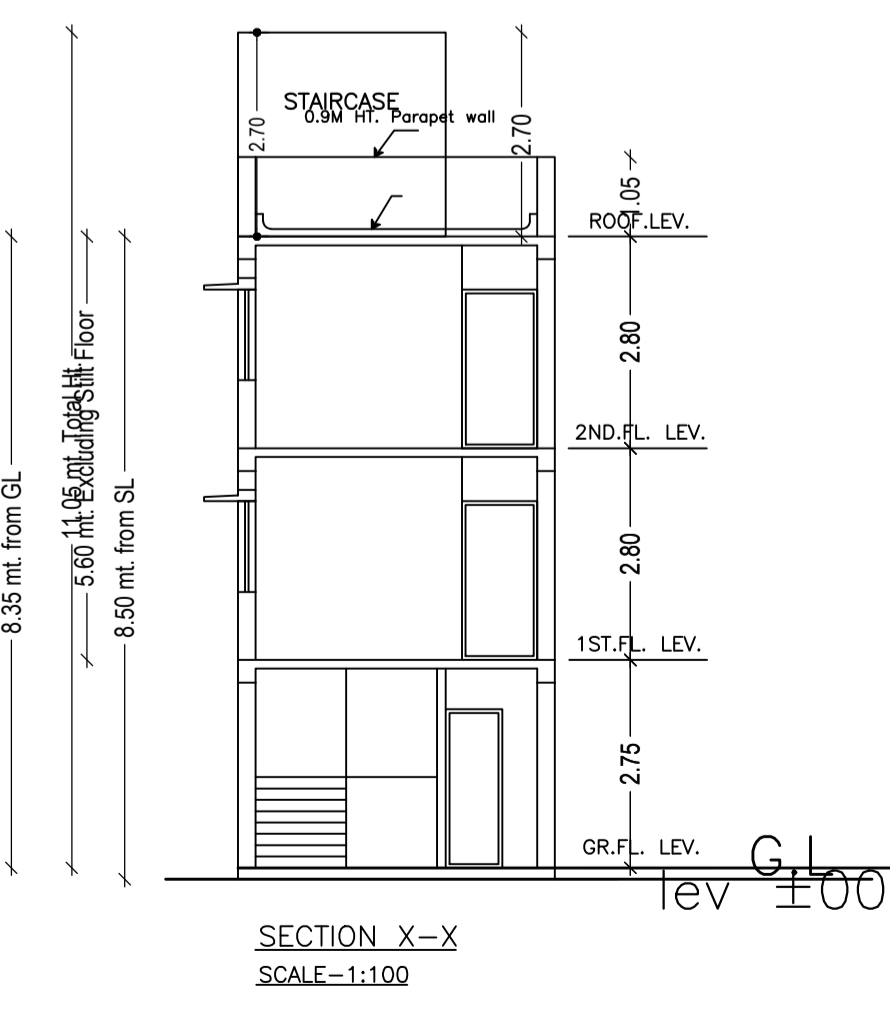

SECTION X-X SCALE=1:100

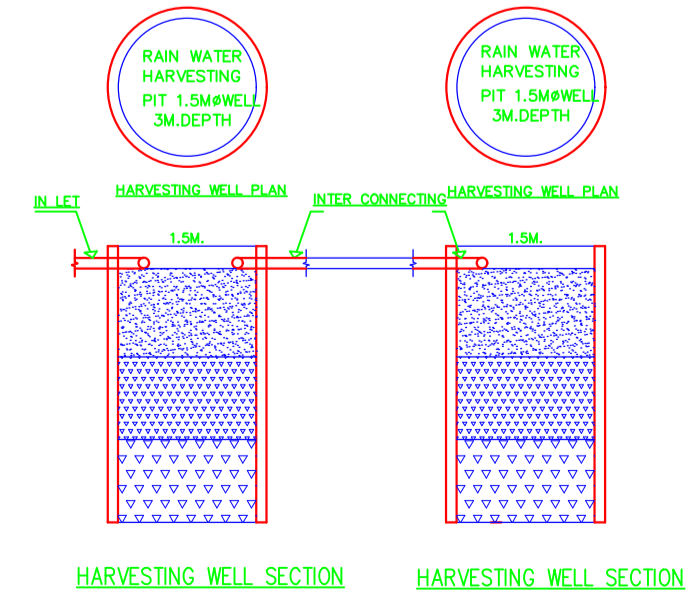

HARVESTING WELL SECTION

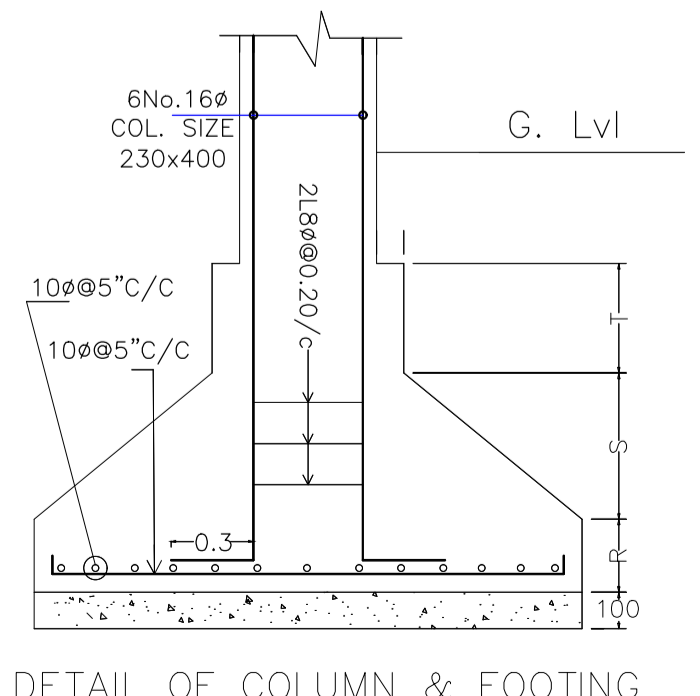

DETAIL OF COLUMN & FOOTING

Building :A1 (LUN KARAN)

Floor Name	Total Built Up Area (Sq.mt.)	Deductions (Area in Sq.mt.)	Proposed FAR Area (Sq.mt.)	Add Area In FAR (Sq.mt.)	Total FAR Area (Sq.mt.)	Total Consumed Additional FAR Area (Sq.mt.)	Tnmt (No.)
Ground And Parking Floor	40.86	2.92	27.83	0.00	10.11	10.11	00
First Floor	40.86	0.00	40.86	0.00	40.86	40.86	01
Second Floor	40.86	0.00	40.86	0.00	40.86	40.86	01
Terrace Floor	0.00	0.00	0.00	0.00	0.00	0.00	00
Total:	122.58	2.92	27.83	10.11	91.83	91.83	02
Total Number of Same Buildings	1						
Total:	122.58	2.92	27.83	10.11	91.83	91.83	02

SCHEDULE OF DOOR:

BUILDING NAME	NAME	LENGTH	HEIGHT	NOS
A1 (LUN KARAN)	D2	0.80	2.10	04
A1 (LUN KARAN)	D	0.95	2.10	02
A1 (LUN KARAN)	D1	1.00	2.10	01
A1 (LUN KARAN)	OPEN	1.22	2.10	01

SCHEDULE OF WINDOW/VENTILATION:

BUILDING NAME	NAME	LENGTH	HEIGHT	NOS
A1 (LUN KARAN)	V	0.60	0.60	02
A1 (LUN KARAN)	W2	0.90	1.20	02
A1 (LUN KARAN)	W1	1.20	1.20	05
A1 (LUN KARAN)	W3	1.20	1.20	01

AREA STATEMENT (JAMSHEDPUR NAC)		VERSION NO. : 1.0.14
PROJECT DETAIL :		VERSION DATE: 11/07/2017
Region: JHARKHAND URBAN LOCAL BODIES	Plot Use: Residential	
District: EAST SINGHBHUM	Plot SubUse: Residential Bldg/Apartment	
Authority: JAMSHEDPUR NAC	Plot/Nearby/Religious/Structure: NA	
Inward_No: JNAC/BP/0030/W2/2017	Plot/SubPlot No: 1271	
Application Type: General Proposal	North: Survey No. - Alley	
Project Type: Building Permission	South: Road Width - 8.35	
Nature of Development: New	East: Plot No. - 1272	
Location of Development Area: Old Area		
AREA DETAILS :		SQ.MT.
AREA OF PLOT (Minimum)	(A)	80.70
NET AREA OF PLOT (Gross Plot Area - Deduction from Gross Plot area)	(A-Deductions)	80.70
Deduction for Balance Plot Area (from Gross Plot Area)		
Common Plot		9.95
Total		9.95
BALANCE AREA OF PLOT (Net Plot Area - Recreational/Amenity space)	(A-Deductions)	70.75
PLOT AREA FOR COVERAGE (Net Plot Area)	(A-Deductions)	80.70
Plot Area for FAR (Net Plot Area - Road/Widening Area)	(A-Deductions)	80.70
COVERAGE CHECK		
Permissible Coverage area ( 70.00 % )		56.49
Proposed Coverage Area ( 50.63 % )		40.86
Total Prop. Coverage Area ( 50.63 % )		40.86
Balance coverage area ( 19.37 % )		15.63
FAR CHECK		
Perm. FAR Area ( 2.50 )		201.75
Total Perm. FAR area		201.75
Residential FAR		81.72
Proposed FAR Area		91.83
Total Proposed FAR Area		91.83
Consumed FAR (Factor)		1.14
Balance FAR Area		109.92
BUILT UP AREA CHECK		
Total Proposed BuiltUp Area		122.58
ARCHITECT (Regd)	shreyashi halder	
ENGINEER (Regd)		
SUPERVISOR (Regd)		
OWNER (Regd)	SRI LUN KARAN JAIN AND OTHERS	
DEVELOPMENT AUTHORITY		LOCAL BODY

COLOR INDEX	
PLOT BOUNDARY	Black
ABUTTING ROAD	Green
PROPOSED CONSTRUCTION	Red
COMMON PLOT	Yellow
ROAD WIDENING AREA	Blue
EXISTING (To be retained)	Orange
EXISTING (To be demolished)	Light Blue

Building USE/SUBUSE Details				
Building Name	Building Use	Building SubUse	Building Structure	
A1 (LUN KARAN)	Residential	Individual Row House	Non-Highrise	

Required Parking (Table 7a)										
Building Name	Type	SubUse	Area (Sq.mt.)	Units	Reqd./Unit	Car	TwoWheeler	Reqd./Unit	Reqd.	Prop.
Total:	-	-	-	-	0	1	-	0	2	

Parking Check (Table 7b)				
Vehicle Type	Reqd.	Prop.	Area	
Car	-	1	12.50	
TwoWheeler	-	2	4.00	
Other Parking	-	-	11.33	
Total	0.00	-	27.83	

Buildingwise Floor FAR Details					
Floor Name	Building Name	Proposed Built Up Area (Sq.mt.)	Proposed FAR Area (Sq.mt.)	Total Proposed Built Up Area (Sq.mt.)	Total FAR Area (Sq.mt.)
Ground And Parking Floor	A1 (LUN KARAN)	40.86	10.11	40.86	10.11
First Floor	A1 (LUN KARAN)	40.86	40.86	40.86	40.86
Second Floor	A1 (LUN KARAN)	40.86	40.86	40.86	40.86
Terrace Floor	A1 (LUN KARAN)	0.00	0.00	0.00	0.00
Total:		122.58	91.83	122.58	91.83

FAR & Tenement Details (Table 4c-1)								
Building	No. of Same Bldg	Total Built Up Area (Sq.mt.)	Deductions (Area in Sq.mt.)	Proposed FAR Area (Sq.mt.)	Add Area In FAR (Sq.mt.)	Total FAR Area (Sq.mt.)	Total Consumed Additional FAR Area (Sq.mt.)	Tnmt (No.)
A1 (LUN KARAN)	1	122.58	2.92	27.83	10.11	91.83	91.83	02
Grand Total	1	122.58	2.92	27.83	10.11	91.83	91.83	2.00

LTP NAME AND SIGNATURE	STRUCTURAL ENG'S NAME AND SIGNATURE	BUILDER NAME AND SIGNATURE
shreyashi halder JNAC/DFTM/0009/2016		