

SITE PLAN

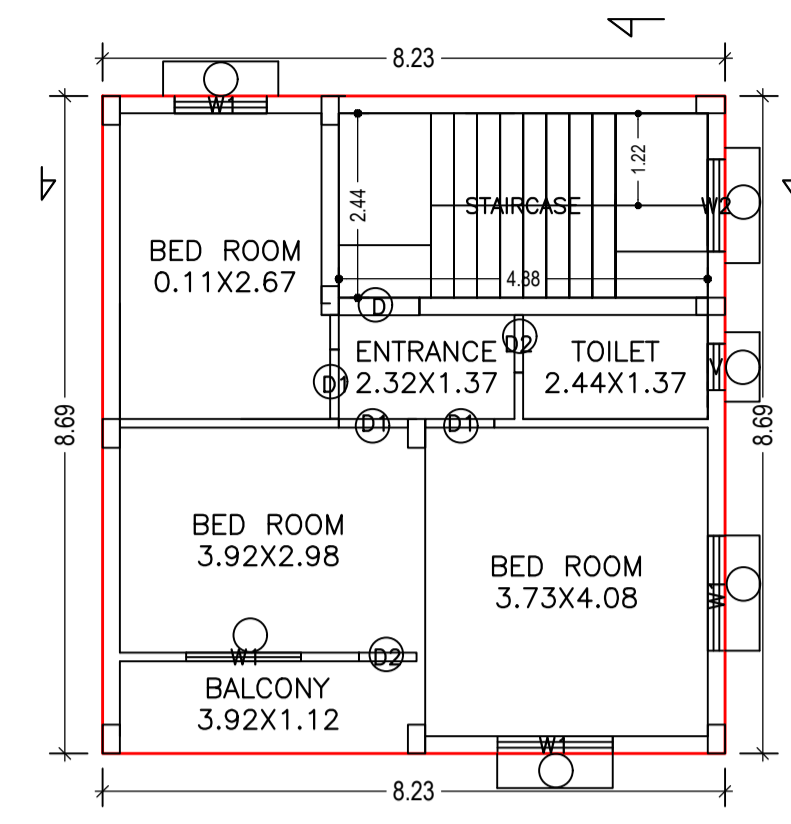

SECOND FLOOR PLAN (Proposed) (SCALE 1:100)

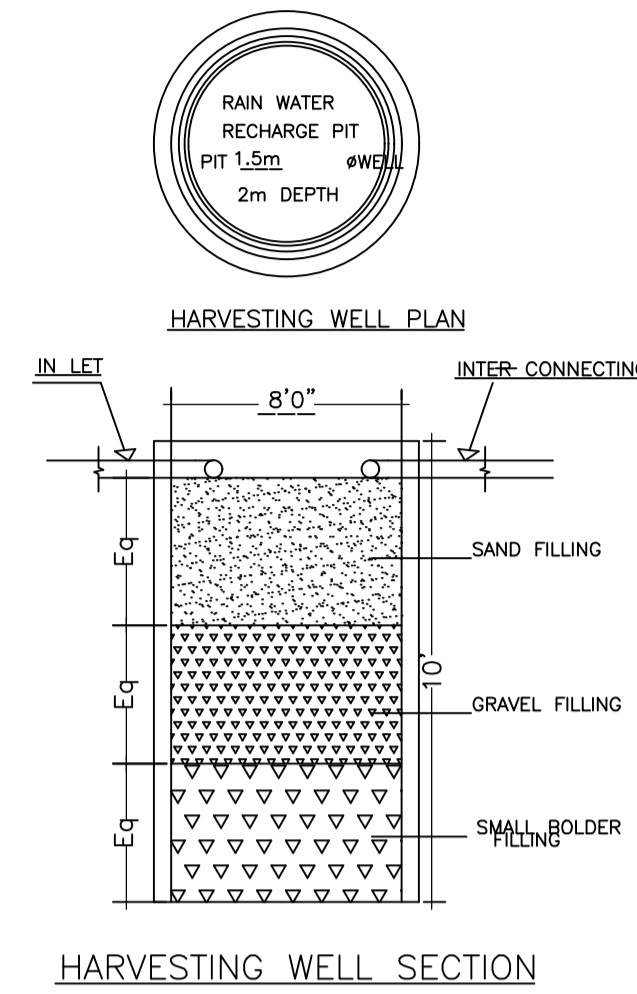

HARVESTING WELL SECTION

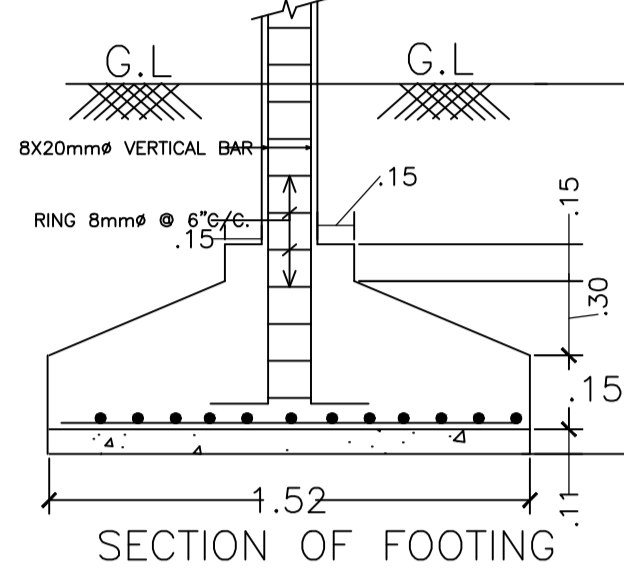

SECTION OF FOOTING

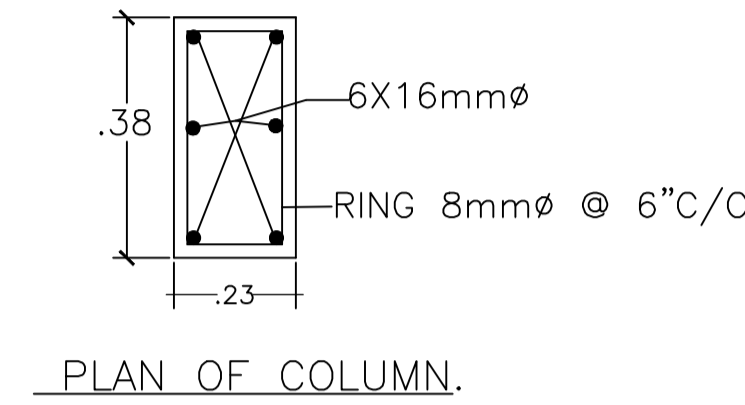

PLAN OF COLUMN.

FAR & Tenement Details (Table 4c-1)

Building	No. of Same Bldg	Total Built Up Area (Sq.mt.)	Deductions (Area in Sq.mt.)		Proposed FAR Area (Sq.mt.)	Add Area in FAR (Sq.mt.)	Total FAR Area (Sq.mt.)	Total Consumed Additional FAR Area (Sq.mt.)	Tnmt (No.)
			Parking	Resi.					
A (SRI HEMANT KUMAR AND OTHERS)	1	214.72	59.68	143.14	143.14	11.90	155.04	155.04	02
Grand Total :	1	214.72	59.68	143.14	143.14	11.90	155.04	155.04	2.00

AREA STATEMENT (JAMSHEDPUR NAC)		VERSION NO. : 1.0.14
PROJECT DETAIL :		VERSION DATE: 11/07/2017
Region: JHARKHAND URBAN LOCAL BODIES	Plot Use: Residential	
District: EAST SINGHBHUM	Plot SubUse: Residential Bldg/Apartment	
Authority: JAMSHEDPUR NAC	Plot/Nearby/Religious/Structure: NA	
Inward No.: JNAC/EP/020/W2/2017	Plot/SubPlot No.: 1235	
Application Type: General Proposal	North: Plot No. - 1234	
Project Type: Building Permission	South: Plot No. - 1236	
Nature of Development: New	East: Road Width - 6	
Location of Development Area: Old Area	West: Survey No. - ALLEY	
AREA DETAILS :		SQ.MT.
AREA OF PLOT (Minimum)	(A)	111.48
NET AREA OF PLOT (Gross Plot Area - Deduction from Gross Plot area)	(A-Deductions)	111.48
Deduction for Balance Plot Area (from Gross Plot Area)		
Common Plot		14.81
Total		14.81
BALANCE AREA OF PLOT (Net Plot Area - Recreational/Amenity space)	(A-Deductions)	96.67
PLOT AREA FOR COVERAGE (Net Plot Area)	(A-Deductions)	111.48
Plot Area for FAR (Net Plot Area + Road Widening Area)	(A-Deductions)	111.48
COVERAGE CHECK		
Permissible Coverage area (70.00 %)		78.04
Proposed Coverage Area (64.20 %)		71.57
Total Prop. Coverage Area (64.2 %)		71.57
Balance coverage area (5.80 %)		6.47
FAR CHECK		
Perm. FAR Area (1.80)		200.66
Total Perm. FAR area		200.66
Residential FAR		143.14
Proposed FAR Area		155.04
Total Proposed FAR Area		155.04
Consumed FAR (Factor)		1.39
Balance FAR Area		45.62
BUILT UP AREA CHECK		
Total Proposed BuiltUp Area		214.72
ARCHITECT (Regd)	L K Suman	
ENGINEER (Regd)		
SUPERVISOR (Regd)		
OWNER (Regd)	SRI HEMANT KUMAR AND OTHERS	
DEVELOPMENT AUTHORITY	LOCAL BODY	

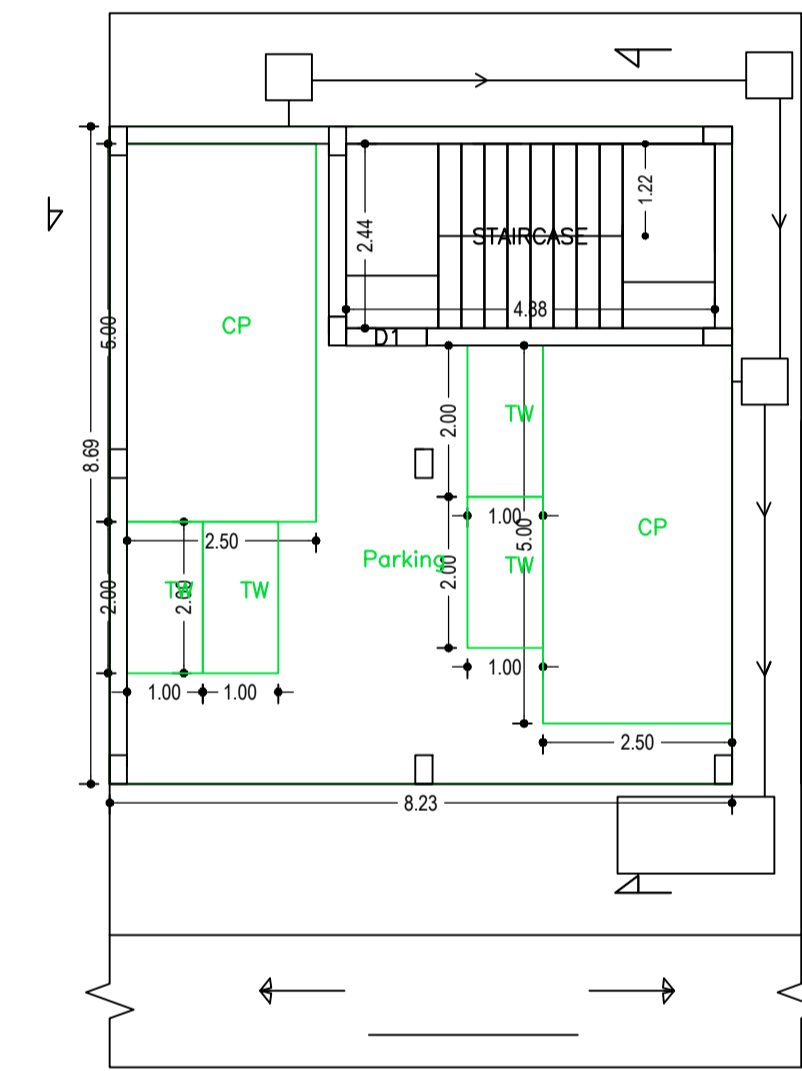

GROUND AND PARKING FLOOR PLAN (SCALE 1:100)

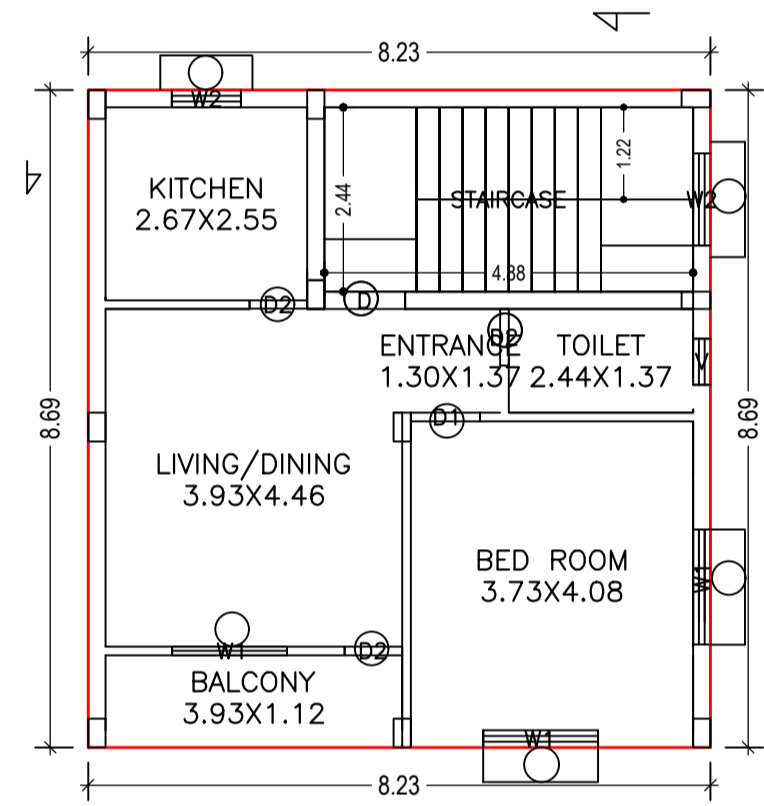

FIRST FLOOR PLAN (Proposed) (SCALE 1:100)

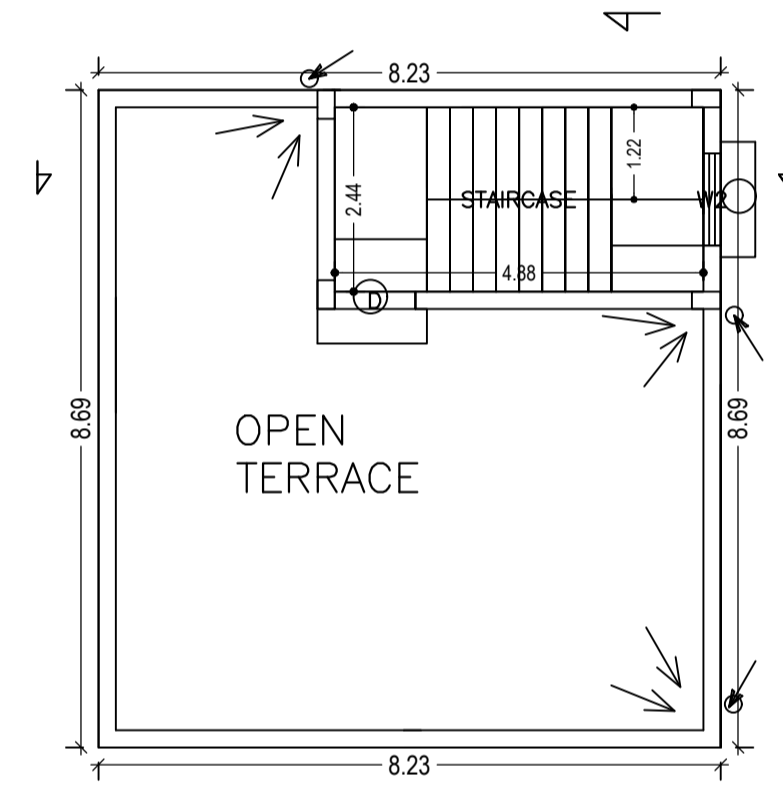

TERRACE FLOOR PLAN (SCALE 1:100)

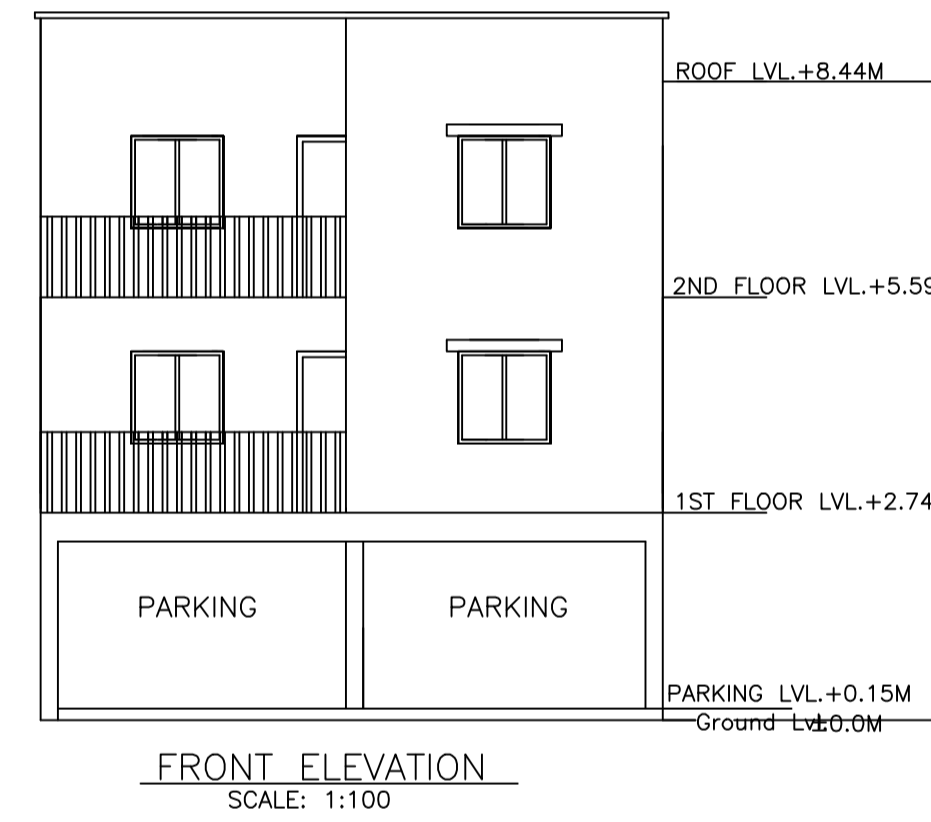

FRONT ELEVATION (SCALE: 1:100)

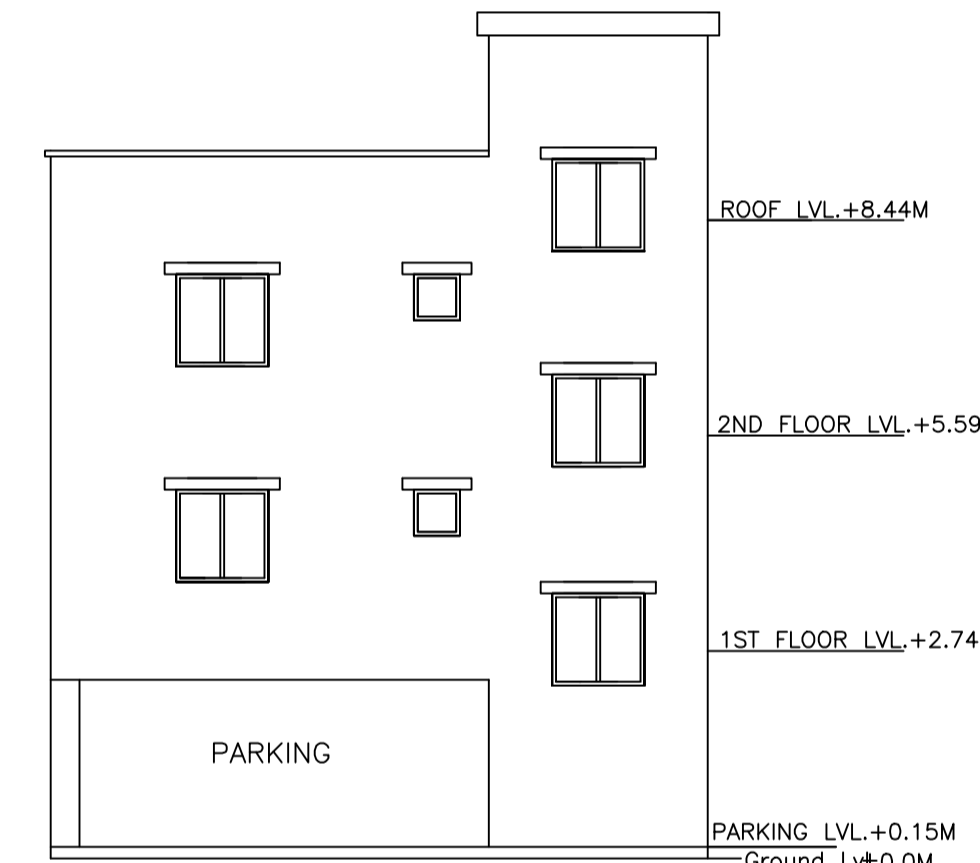

SIDE ELEVATION (SCALE: 1:100)

COLOR INDEX	
PLOT BOUNDARY	Black
ABUTTING ROAD	Green
PROPOSED CONSTRUCTION	Red
COMMON PLOT	Yellow
ROAD WIDENING AREA	Blue
EXISTING (To be retained)	Light Blue
EXISTING (To be demolished)	Dark Blue

Buildingwise Floor FAR Details

Floor Name	Building Name		Total	
	A (SRI HEMANT KUMAR AND OTHERS) Proposed Built Up Area (Sq.mt.)	Proposed FAR Area (Sq.mt.)	Total Proposed Built Up Area (Sq.mt.)	Total FAR Area (Sq.mt.)
Ground And Parking Floor	71.58	11.90	71.58	11.90
First Floor	71.57	71.57	71.57	71.57
Second Floor	71.57	71.57	71.57	71.57
Terrace Floor	0.00	0.00	0.00	0.00
Total :	214.72	155.04	214.72	155.04

Building USE/SUBUSE Details

Building Name	Building Use	Building SubUse	Building Structure
A (SRI HEMANT KUMAR AND OTHERS)	Residential	Individual Row House	Non-Highrise

Required Parking (Table 7a)

Building Name	Type	SubUse	Area (Sq.mt.)		Units		Car		TwoWheeler	
			Reqd.	Prop.	Reqd./Unit	Prop.	Reqd./Unit	Prop.		
Total :	-	-	-	-	-	-	0	2	-	0

Parking Check (Table 7b)

Vehicle Type	Reqd.		Prop.	
	No.	Area	No.	Area
Car	-	-	2	25.00
TwoWheeler	-	-	4	8.00
Other Parking	-	-	-	26.68
Total		0.00		59.68

Building :A (SRI HEMANT KUMAR AND OTHERS)

Floor Name	Total Built Up Area (Sq.mt.)	Deductions (Area in Sq.mt.)		Proposed FAR Area (Sq.mt.)	Add Area in FAR (Sq.mt.)	Total FAR Area (Sq.mt.)	Total Consumed Additional FAR Area (Sq.mt.)	Tnmt (No.)
		Parking	Resi.					
Ground And Parking Floor	71.58	59.68	0.00	11.90	11.90	11.90	11.90	00
First Floor	71.57	0.00	71.57	0.00	71.57	71.57	71.57	01
Second Floor	71.57	0.00	71.57	0.00	71.57	71.57	71.57	01
Terrace Floor	0.00	0.00	0.00	0.00	0.00	0.00	0.00	00
Total :	214.72	59.68	143.14	11.90	155.04	155.04	155.04	02
Total Number of Same Buildings	1							
Total :	214.72	59.68	143.14	11.90	155.04	155.04	155.04	02

SCHEDULE OF DOOR:

BUILDING NAME	NAME	LENGTH	HEIGHT	NOS
A (SRI HEMANT KUMAR AND OTHERS)	D2	0.75	2.10	01
A (SRI HEMANT KUMAR AND OTHERS)	D2	0.76	2.10	04
A (SRI HEMANT KUMAR AND OTHERS)	D1	0.91	2.10	04
A (SRI HEMANT KUMAR AND OTHERS)	D	1.07	2.10	02

SCHEDULE OF WINDOW/VENTILATION:

BUILDING NAME	NAME	LENGTH	HEIGHT	NOS
A (SRI HEMANT KUMAR AND OTHERS)	V	0.61	0.60	02
A (SRI HEMANT KUMAR AND OTHERS)	W2	0.91	1.20	01
A (SRI HEMANT KUMAR AND OTHERS)	W2	1.22	1.20	03
A (SRI HEMANT KUMAR AND OTHERS)	W1	1.22	1.20	01
A (SRI HEMANT KUMAR AND OTHERS)	W1	1.52	1.20	06

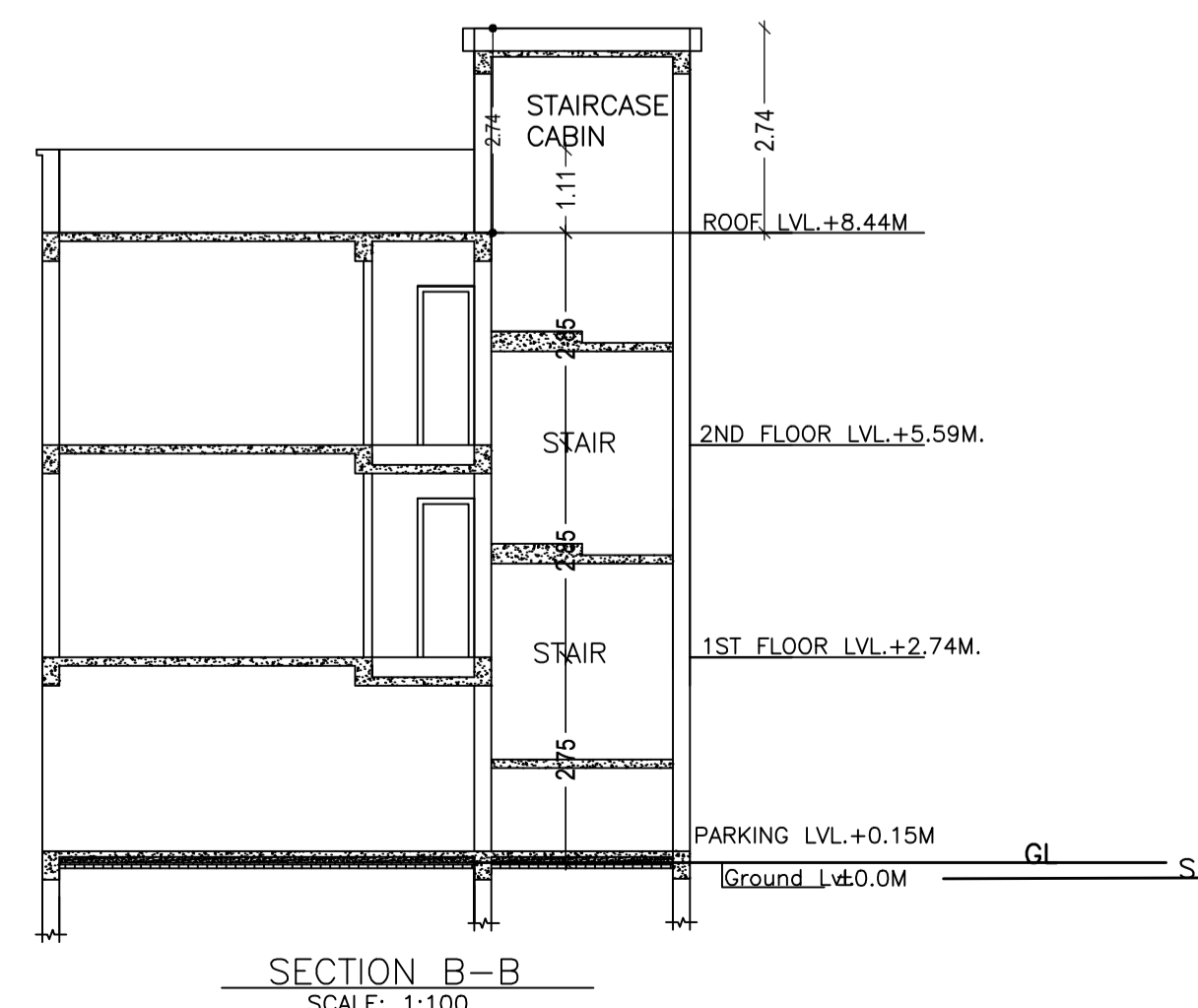

SECTION B-B (SCALE: 1:100)

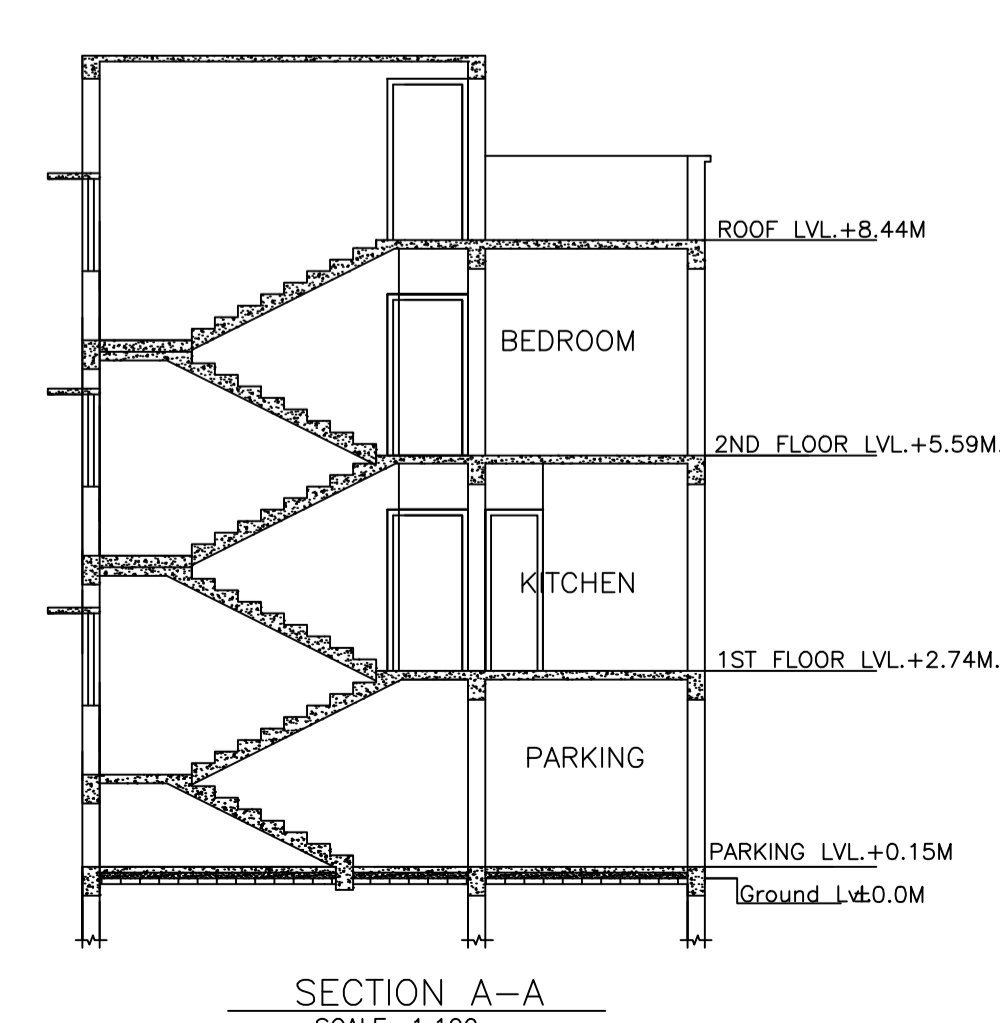

SECTION A-A (SCALE: 1:100)

LTP NAME AND SIGNATURE	STRUCTURAL ENG'S NAME AND SIGNATURE	BUILDER NAME AND SIGNATURE
L K Suman JNAC/ENG/0006/2016		