

Proposal Basic Information	
Proposal File No.	JNAC/BP/0104/W7/2018
Owner Name	MADHUBAN KUMAR AND RAGHUBIR PRASAD
Khata No	245
Plot No	3297
Village Name	SAKCHI
Use	Residential
SubUse	Residential Bldg/Apartment

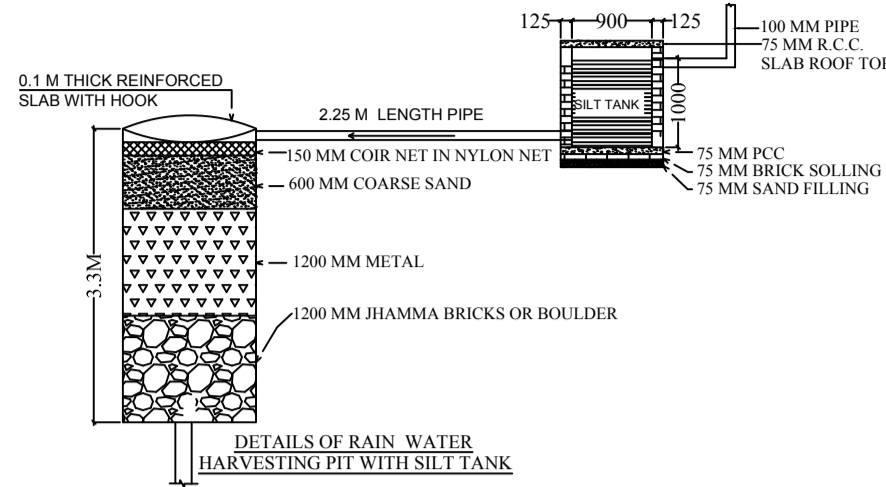
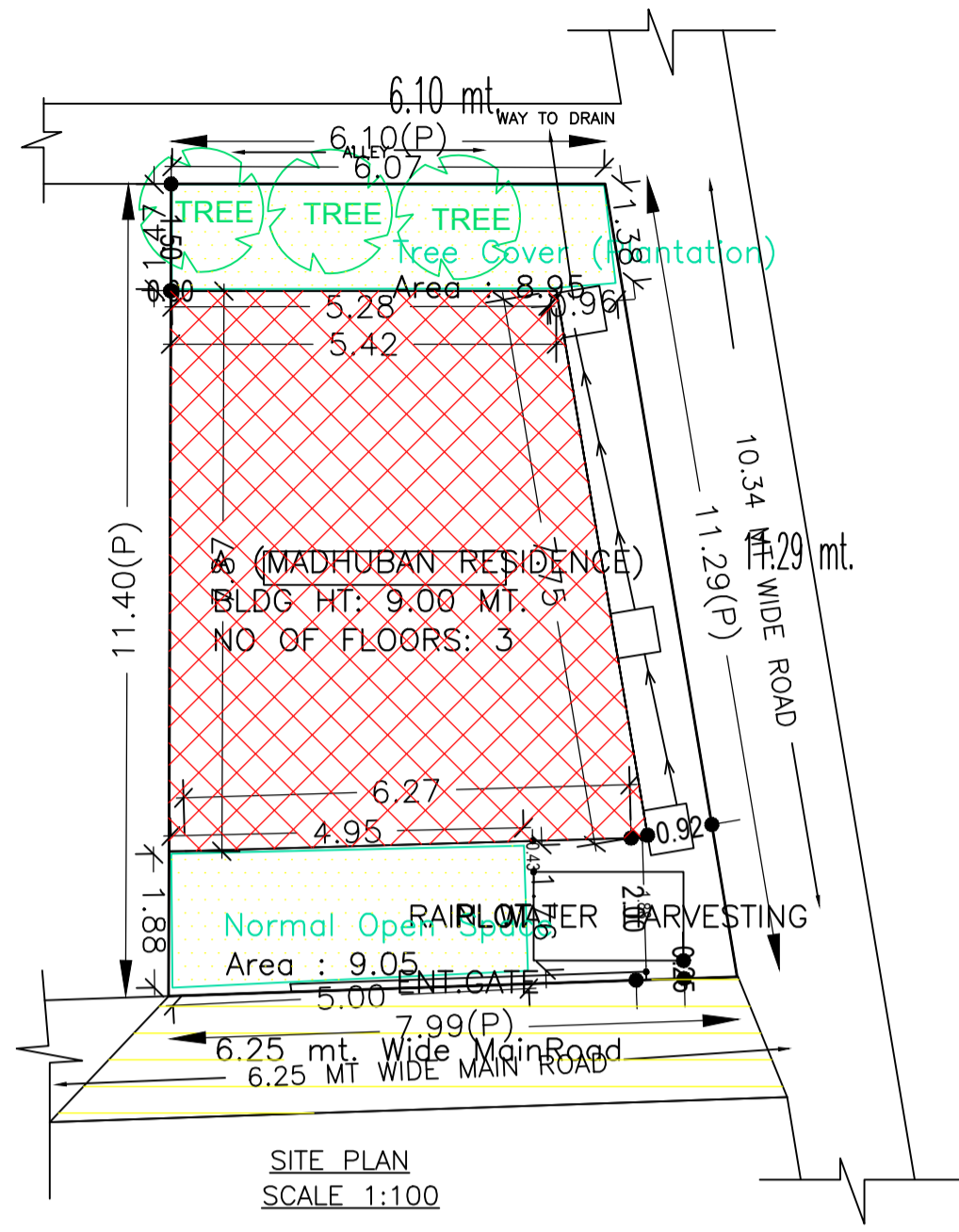

UnitBUA Table for Building :A (MADHUBAN RESIDENCE)

FLOOR	Name	UnitBUA Type	UnitBUA Area	Carpet Area	No. of Rooms	No. of Tenement
FIRST FLOOR PLAN	SPLIT UNIT 1	FLAT	82.04	80.11	5	1
SECOND FLOOR PLAN	SPLIT UNIT 1	FLAT	0.00	0.00	5	0
Total:	-	-	82.04	80.11	10	1

SCHEDULE OF DOOR:

BUILDING NAME	NAME	LENGTH	HEIGHT	NOS
A (MADHUBAN RESIDENCE)	D2	0.75	2.10	04
A (MADHUBAN RESIDENCE)	D1	0.91	2.10	04

SCHEDULE OF WINDOW/VENTILATION:

BUILDING NAME	NAME	LENGTH	HEIGHT	NOS
A (MADHUBAN RESIDENCE)	V	0.61	0.61	02
A (MADHUBAN RESIDENCE)	W2	1.20	1.20	02
A (MADHUBAN RESIDENCE)	WK	1.50	1.00	02
A (MADHUBAN RESIDENCE)	W1	1.50	1.20	02
A (MADHUBAN RESIDENCE)	W	1.80	1.20	02

Building :A (MADHUBAN RESIDENCE)

Floor Name	Total Built Up Area (Sq.mt.)	Deductions (Area in Sq.mt.)			Proposed FAR Area (Sq.mt.)	Add Area in FAR (Sq.mt.)	Total FAR Area (Sq.mt.)	Total Consumed Additional FAR Area (Sq.mt.)	Tnmt (No.)
		Lift	Accessory Use	Parking					
Ground Floor	47.30	0.00	3.05	33.78	0.00	7.23	10.47	10.47	00
First Floor	47.25	3.24	0.00	0.00	44.01	0.00	44.01	44.01	01
Second Floor	47.25	3.24	0.00	0.00	44.01	0.00	44.01	44.01	00
Terrace Floor	0.00	0.00	0.00	0.00	0.00	0.00	0.00	0.00	00
Total :	141.80	6.48	3.05	33.78	88.02	7.23	98.49	98.49	01

FAR & Tenement Details (Table 4c-1)

Building	No. of Same Bldg	Total Built Up Area (Sq.mt.)	Deductions (Area in Sq.mt.)			Proposed FAR Area (Sq.mt.)	Add Area in FAR (Sq.mt.)	Total FAR Area (Sq.mt.)	Total Consumed Additional FAR Area (Sq.mt.)	Tnmt (No.)
			Lift	Accessory Use	Parking					
A (MADHUBAN RESIDENCE)	1	141.80	6.48	3.05	33.78	88.02	7.23	98.49	98.49	01
Grand Total :	1	141.80	6.48	3.05	33.78	88.02	7.23	98.49	98.49	01

AREA STATEMENT		VERSION NO. : 1.0.30
JAMSHEDPUR NAC		VERSION DATE: 30/06/2018
PROJECT DETAIL:		
Region: JHARKHAND URBAN LOCAL BODIES	Plot Use: Residential	
District: EAST SINGBHUM	Plot SubUse: Residential Bldg/Apartment	
Authority: JAMSHEDPUR NAC	Plot/Nearby/Religious Structure: NA	
Inward No: JNAC/BP/0104/W7/2018	Plot/SubPlot No: 3297	
Application Type: General Proposal	North: -	
Project Type: Building Permission	South: -	
Nature of Development: New	East: -	
Location of Development Area: Old Area	West: -	
AREA DETAILS:		
AREA OF PLOT (Minimum)	(A)	SQ.MT. 79.46
NET AREA OF PLOT(Gross Plot Area - Deduction from Gross Plot area)	(A-Deductions)	79.46
Deduction for Balance Plot Area(from Gross Plot Area)		
Common Plot		18.00
Total		18.00
BALANCE AREA OF PLOT(Net Plot Area - Recreational/Amenity space)	(A-Deductions)	61.46
PLOT AREA FOR COVERAGE(Net Plot Area)	(A-Deductions)	79.46
Plot Area for FAR (Net Plot Area + Road/Widening Area)	(A-Deductions)	79.46
COVERAGE CHECK		
Permissible Coverage area ( 70.00 % )		55.62
Proposed Coverage Area ( 59.53 % )		47.30
Total Prop. Coverage Area ( 59.53 % )		47.30
Balance coverage area ( 10.47 % )		8.32
FAR CHECK		
Perm. FAR Area ( 2.50 )		198.65
Total Perm. FAR area		198.65
Residential FAR		88.01
Proposed FAR Area		98.48
Total Proposed FAR Area		98.48
Consumed FAR (Factor)		1.24
Balance FAR Area		100.17
BUILT UP AREA CHECK		
Total Proposed BuiltUp Area		141.80
ARCHITECT (Regd)	LAWRENCE FRANCIS	
ENGINEER (Regd)		
SUPERVISOR (Regd)		
OWNER (Regd)	MADHUBAN KUMAR AND RAGHUBIR PRASAD	
DEVELOPMENT AUTHORITY		LOCAL BODY

COLOR INDEX	
PLOT BOUNDARY	Black
ABUTTING ROAD	Green
PROPOSED CONSTRUCTION	Red
COMMON PLOT	Yellow
ROAD WIDENING AREA	Blue
EXISTING (To be retained)	Light Blue
EXISTING (To be demolished)	Dark Blue

Buildingwise Floor FAR Details

Floor Name	Building Name		Total	
	Proposed Built Up Area (Sq.mt.)	Proposed FAR Area (Sq.mt.)	Total Proposed Built Up Area (Sq.mt.)	Total FAR Area (Sq.mt.)
Ground Floor	47.30	10.47	47.30	10.47
First Floor	47.25	44.01	47.25	44.01
Second Floor	47.25	44.01	47.25	44.01
Terrace Floor	0.00	0.00	0.00	0.00
Total :	141.80	98.49	141.80	98.49

Building USE/SUBUSE Details

Building Name	Building Use	Building SubUse	Building Structure
A (MADHUBAN RESIDENCE)	Residential	Residential Bldg/Apartment	Non-Highrise

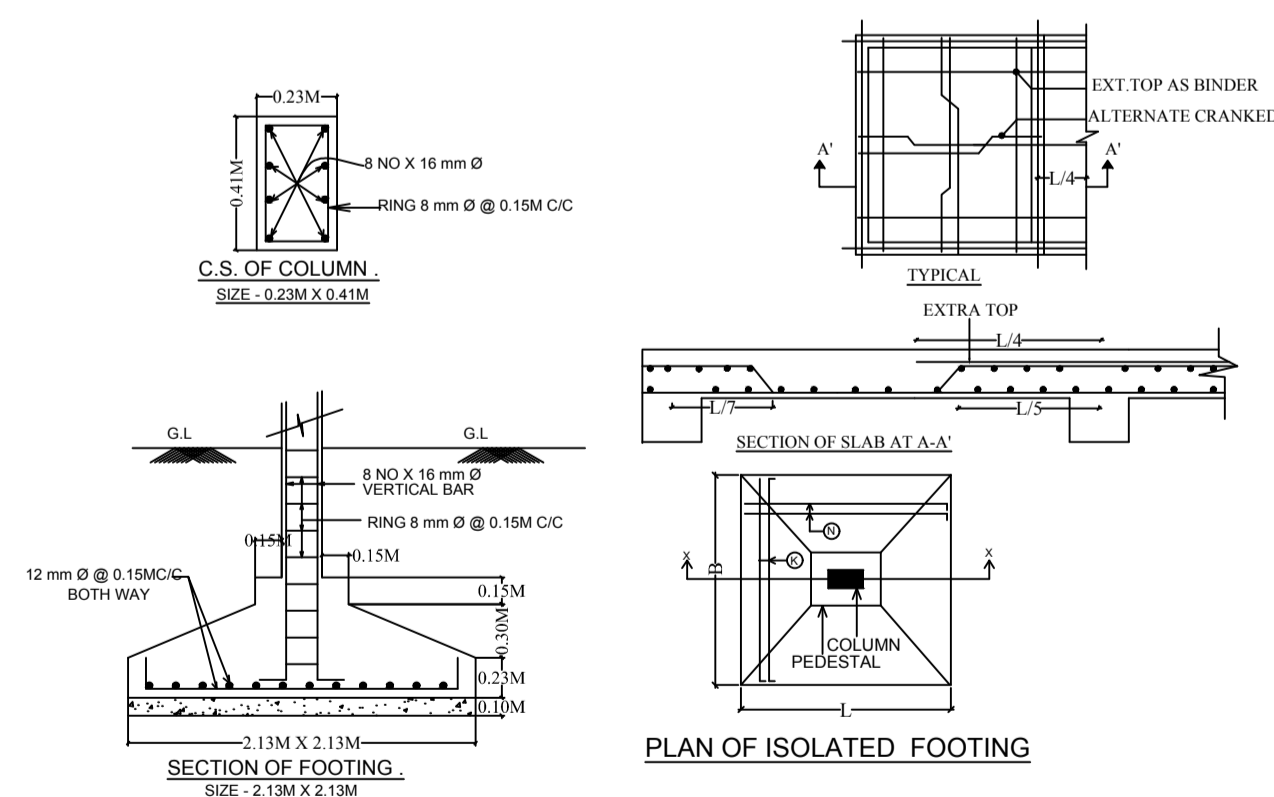
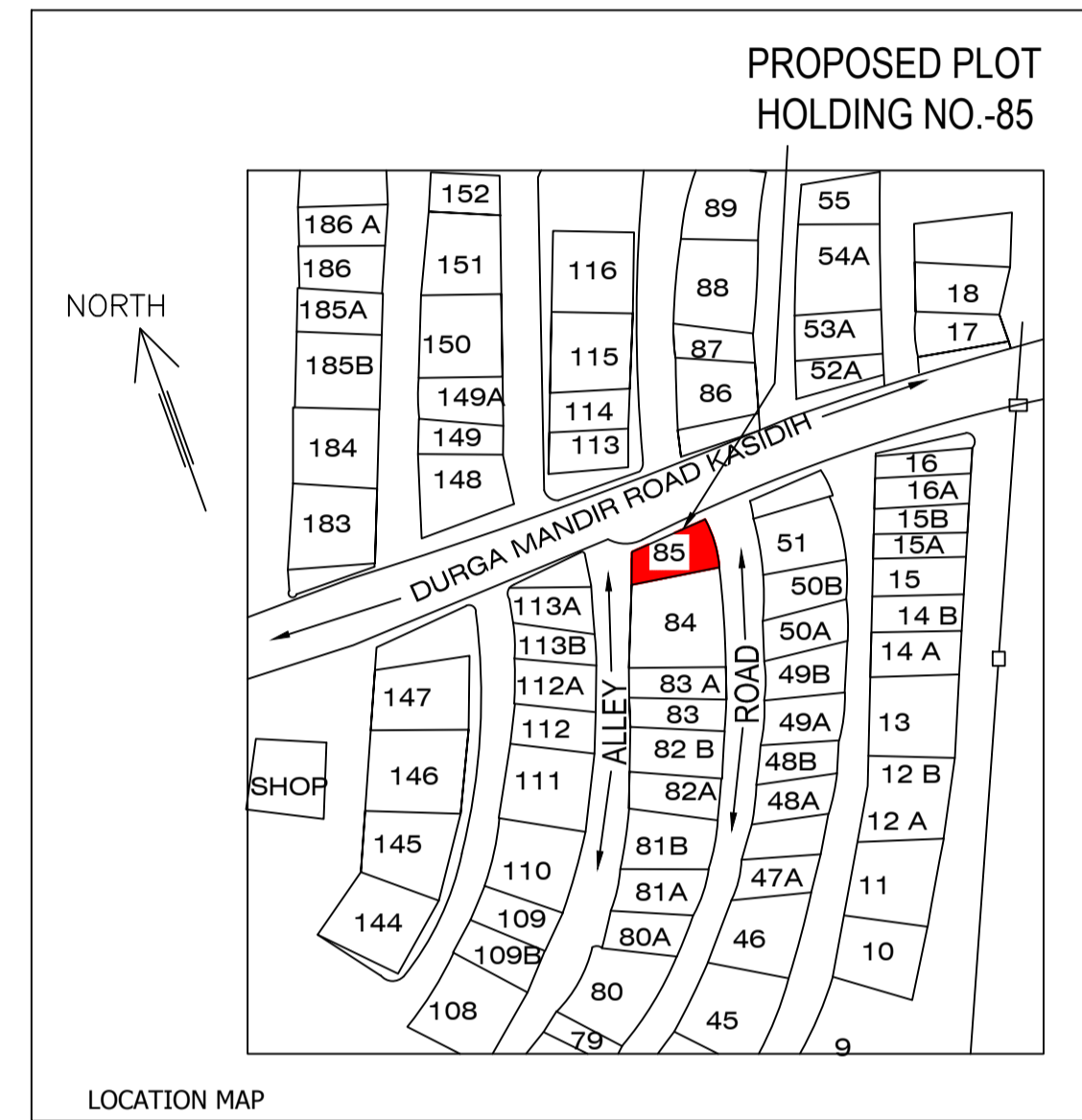

LTP NAME AND SIGNATURE	STRUCTURAL ENG'S NAME AND SIGNATURE	BUILDER NAME AND SIGNATURE	DIGITAL SIGNATURE
LAWRENCE FRANCIS JNAC/ARC/0003/2016			

Proposal Basic Information

Proposal File No.	JNAC/BP/0104/W7/2018
Owner Name	MADHUBAN KUMAR AND RAGHUBIR PRASAD
Khata No	245
Plot No	3297
Village Name	SAKCHI
Use	Residential
SubUse	Residential Bldg/Apartment

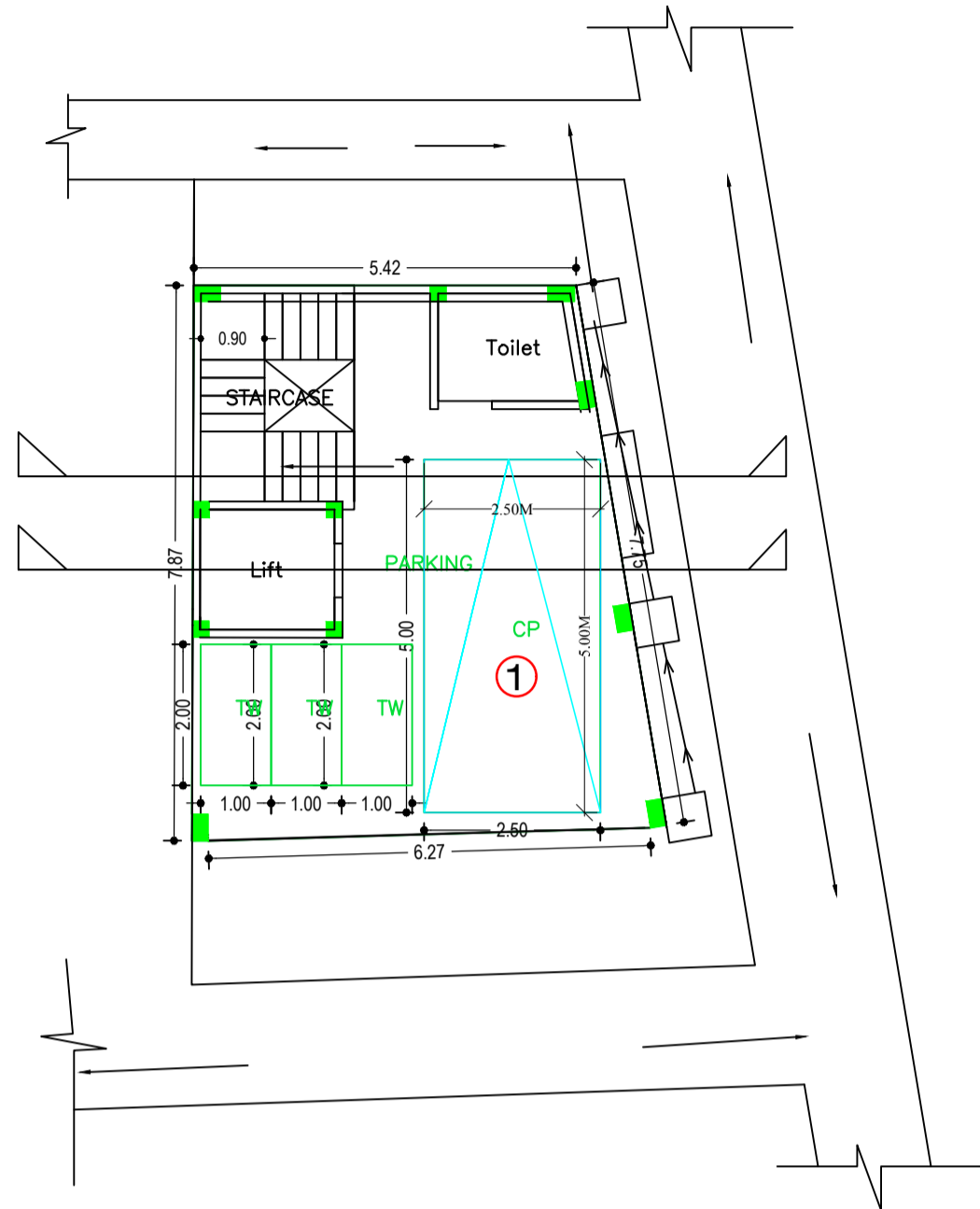

GROUND FLOOR PLAN  
(SCALE 1:100)

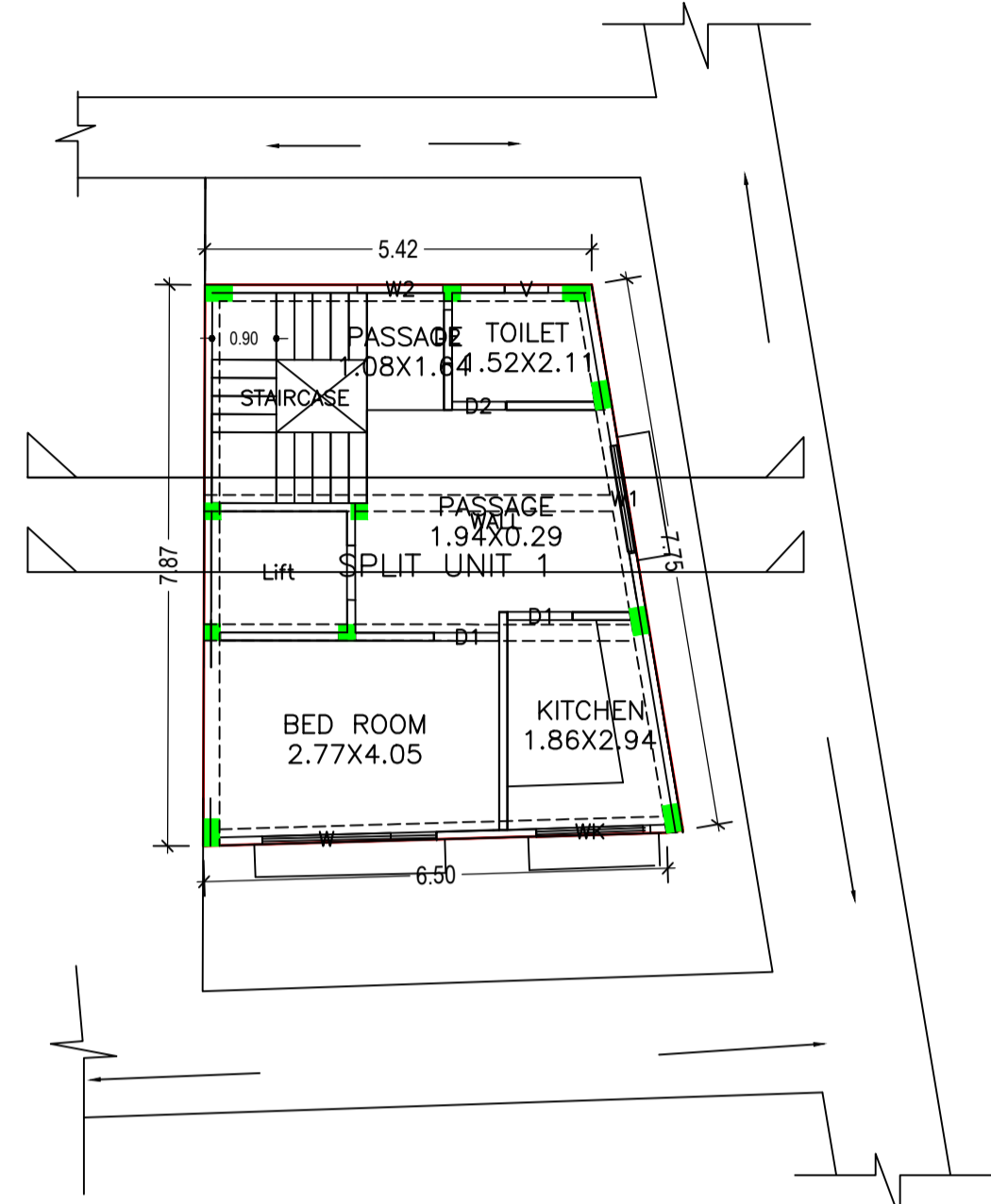

FIRST FLOOR PLAN  
(Proposed)  
(SCALE 1:100)

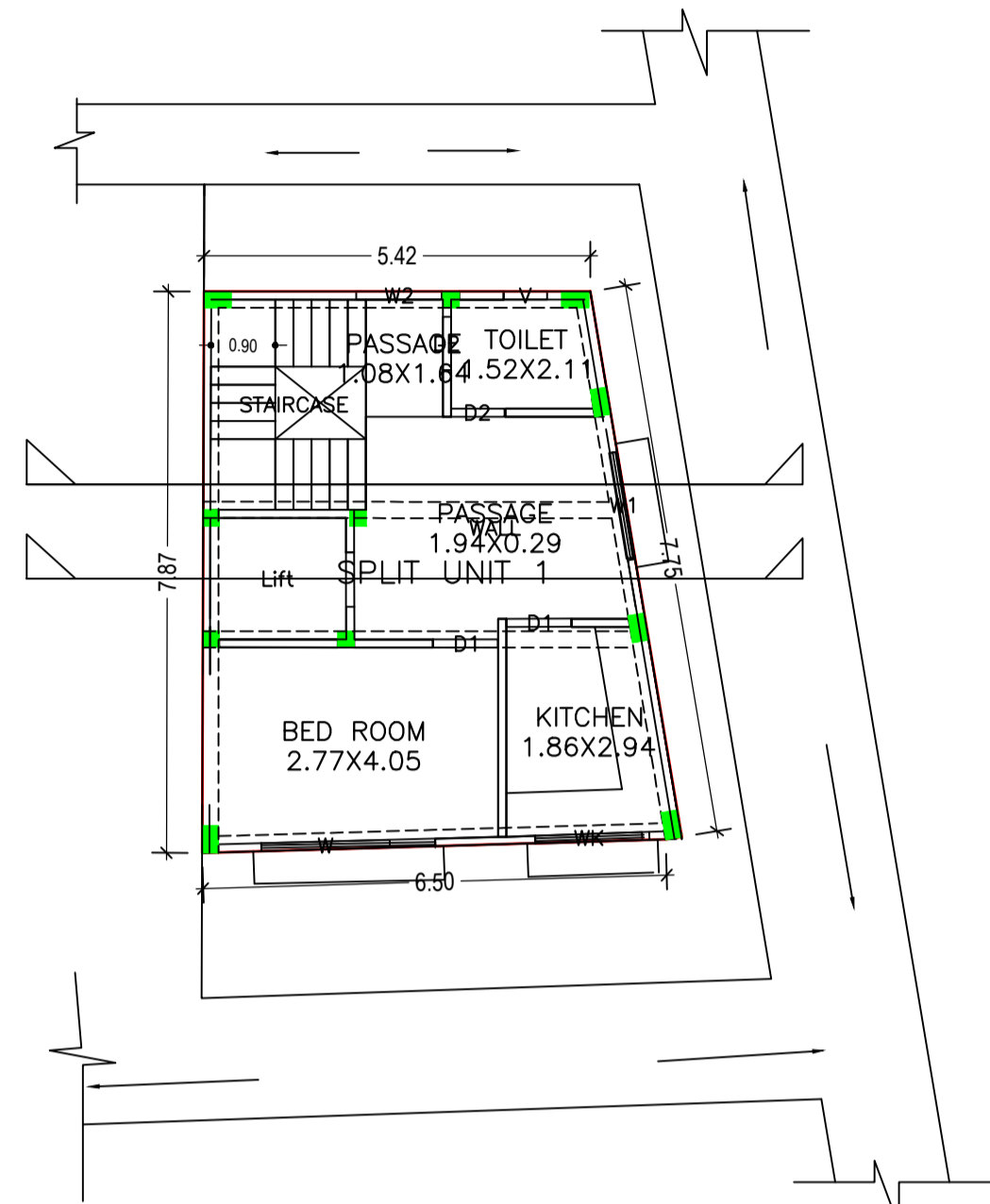

SECOND FLOOR PLAN  
(Proposed)  
(SCALE 1:100)

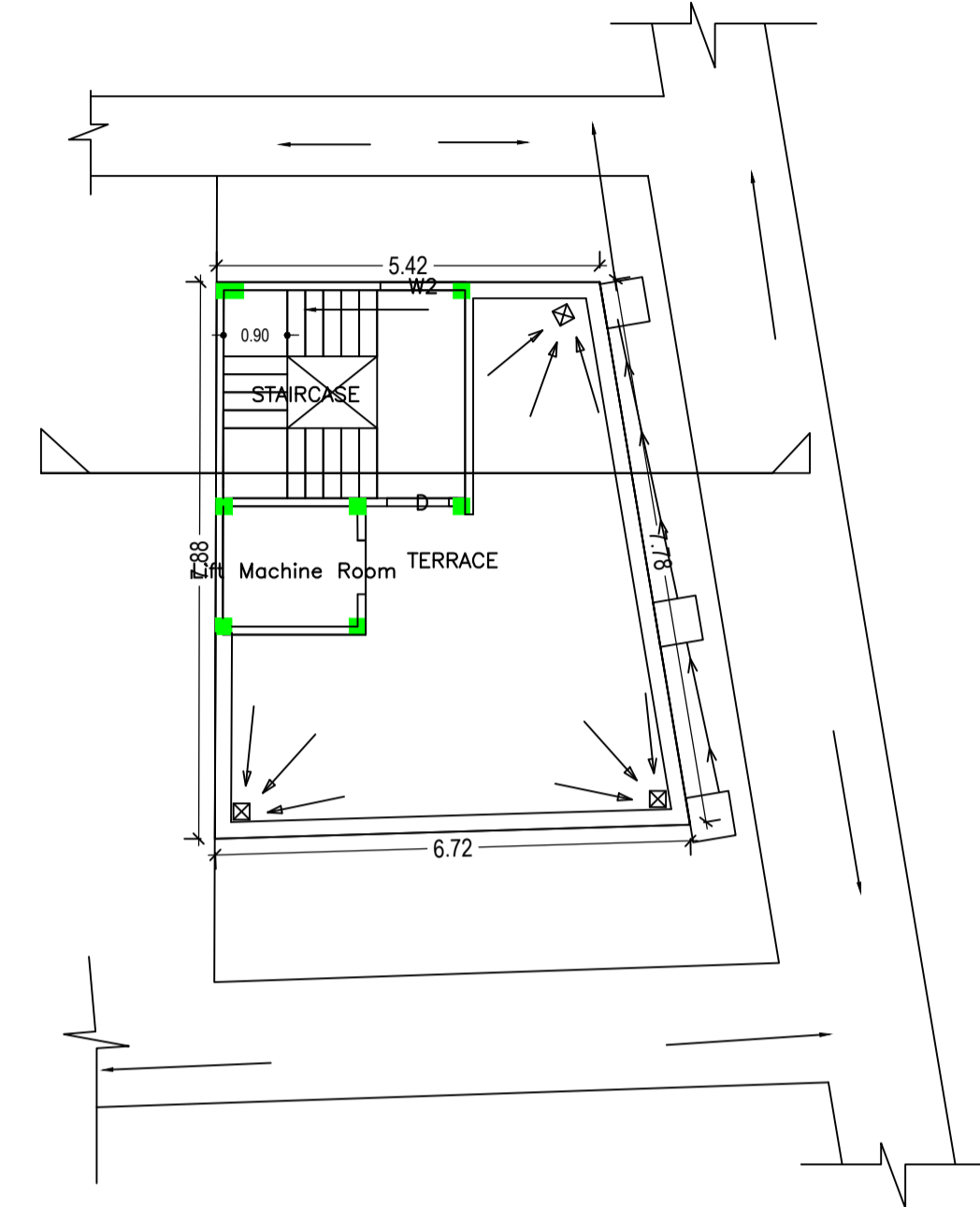

TERRACE FLOOR PLAN  
(SCALE 1:100)

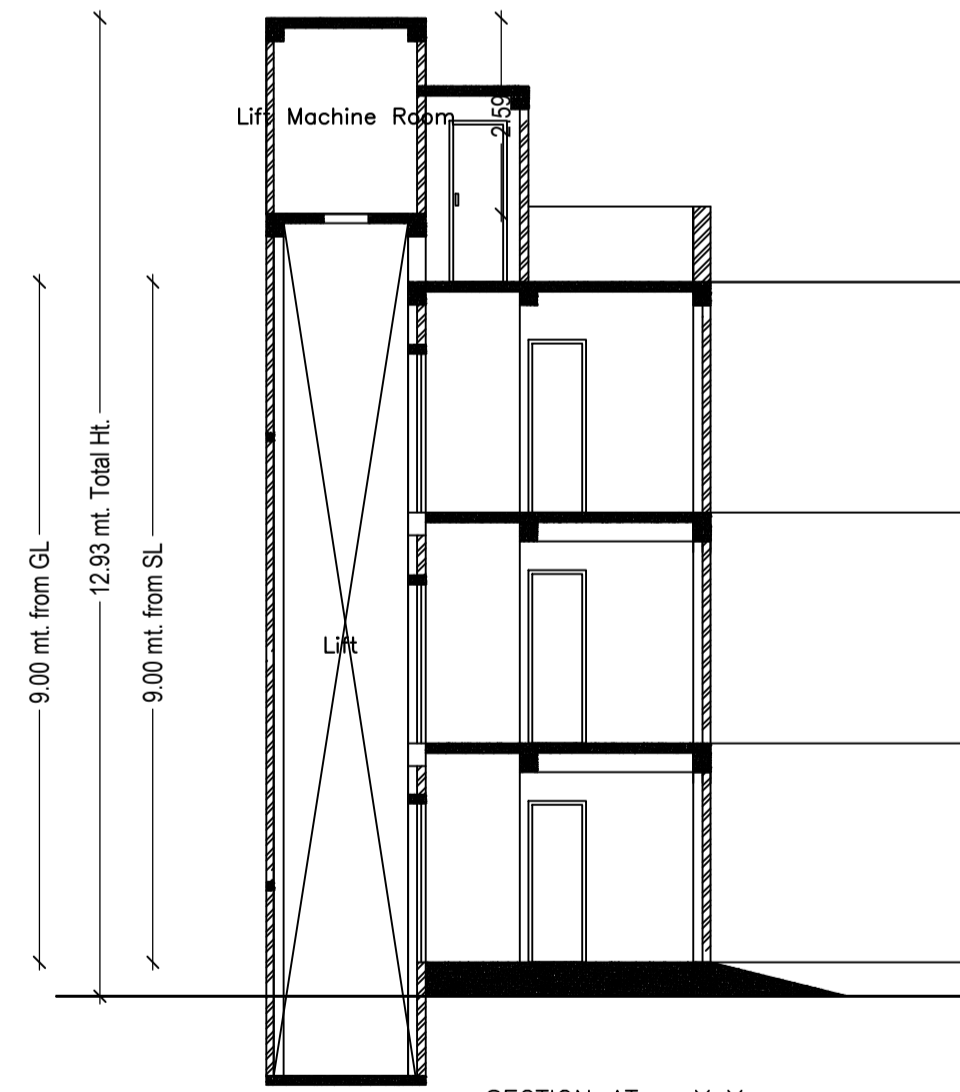

SECTION AT - Y Y

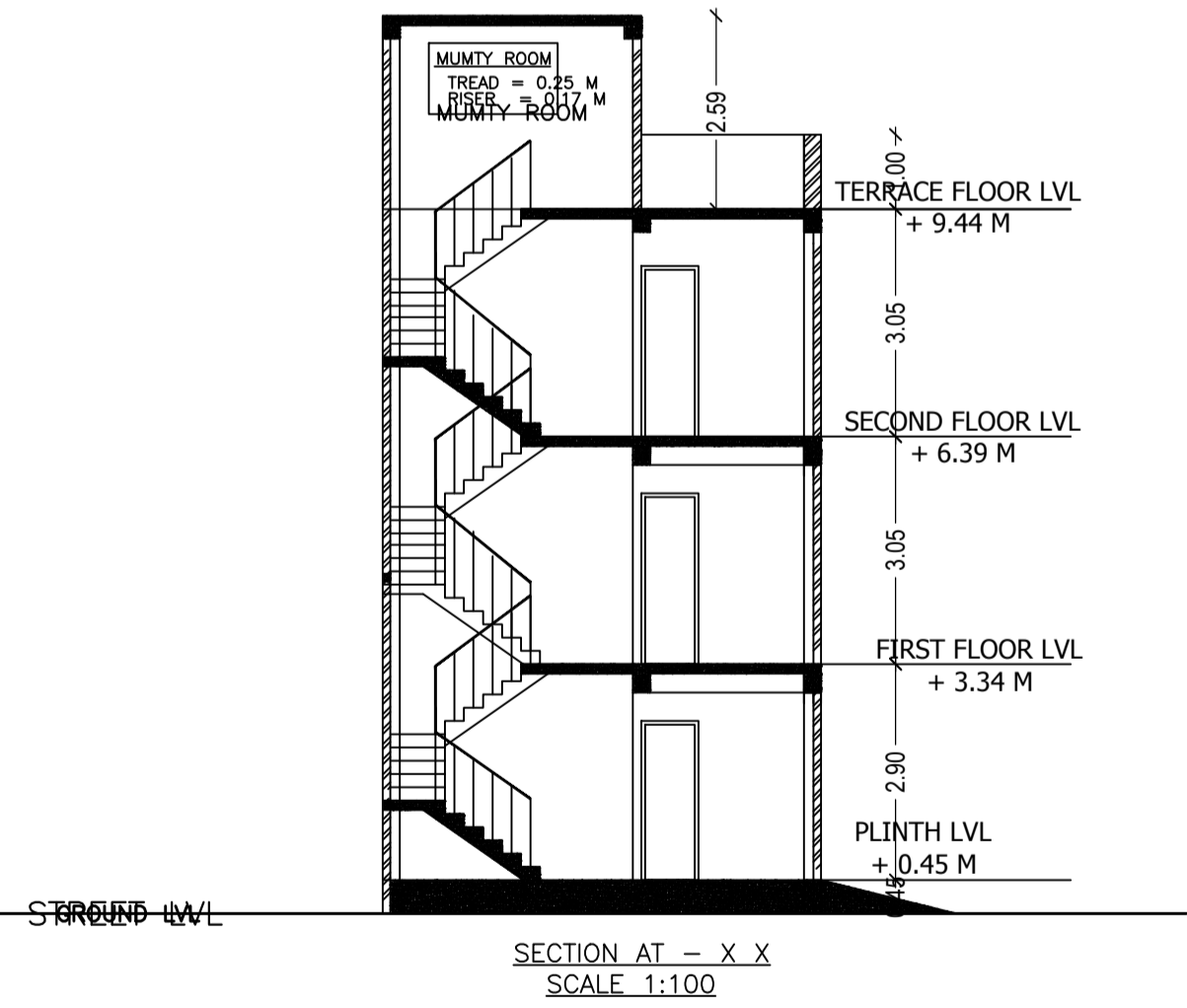

SECTION AT - X X  
SCALE 1:100

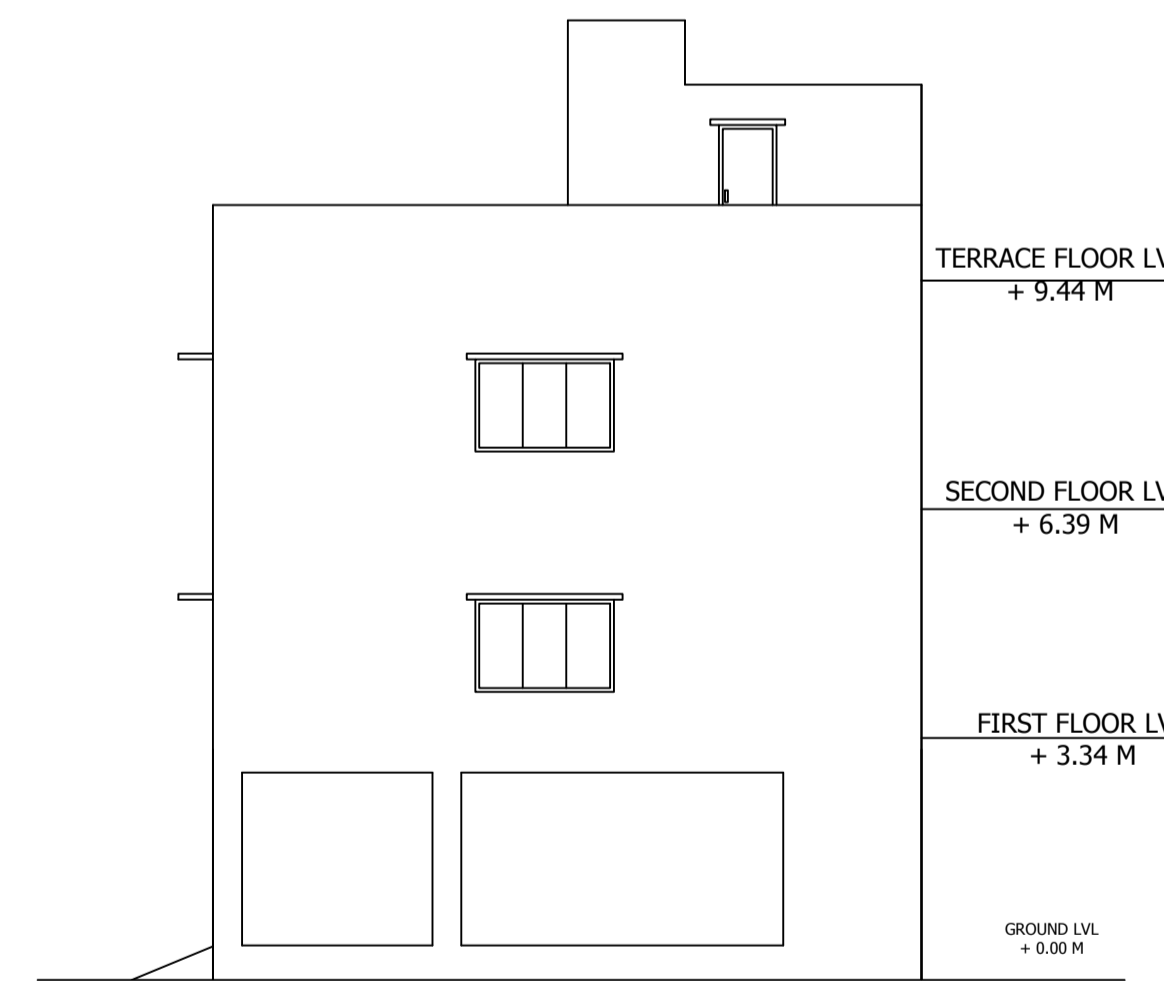

SIDE ELEVATION  
SCALE 1:100

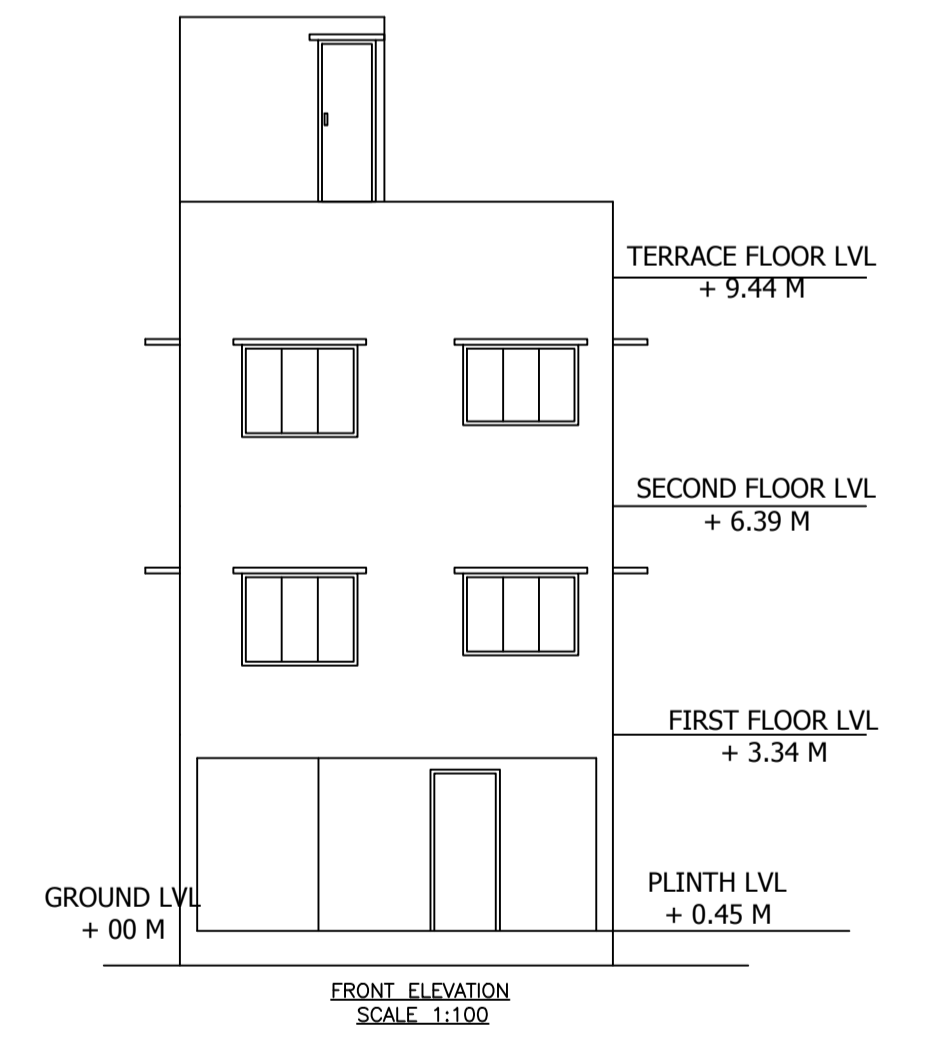

FRONT ELEVATION  
SCALE 1:100

LTP NAME AND SIGNATURE	STRUCTURAL ENG'S NAME AND SIGNATURE	BUILDER NAME AND SIGNATURE	DIGITAL SIGNATURE
LAWRENCE FRANCIS JNACIARC/0003/2016			