

Proposal Basic Information	
Proposal File No.	JNAC/BP/0100/W11/2018
Owner Name	ANJU PRASAD
Khata No	NIL
Plot No	3
Village Name	Sitaramdera
Use	Residential
SubUse	Row House

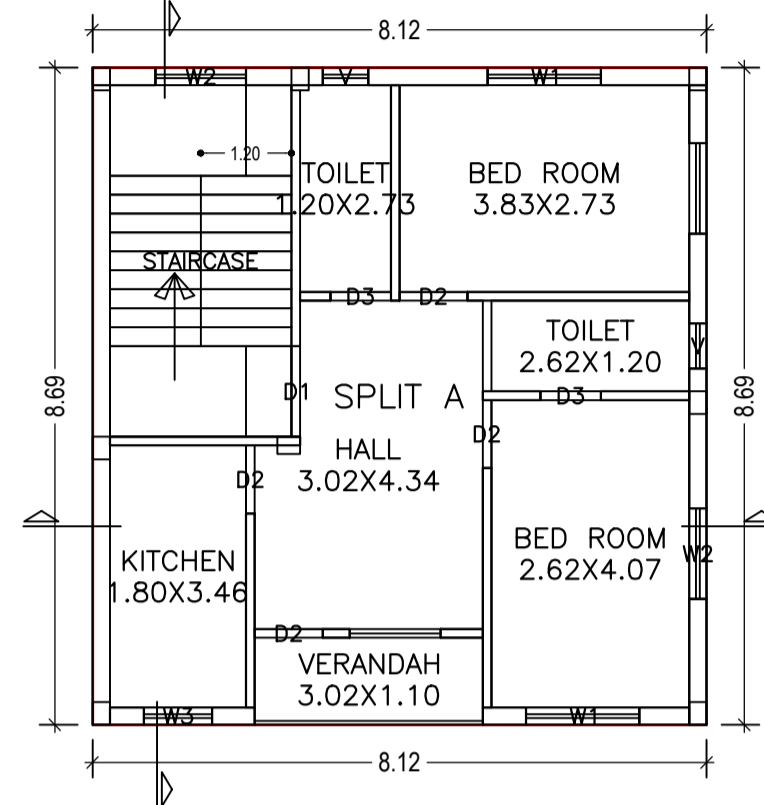

SITE PLAN

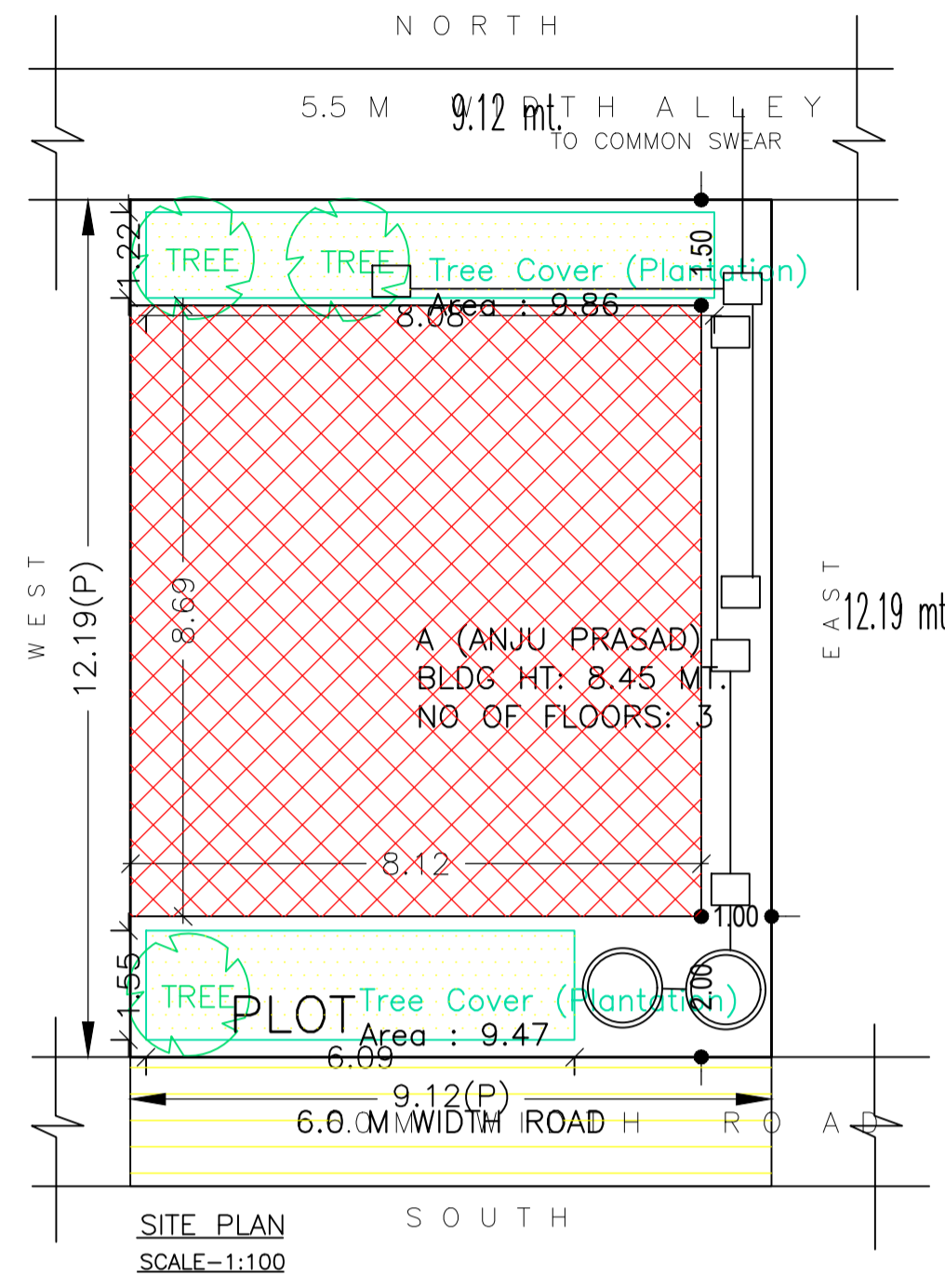
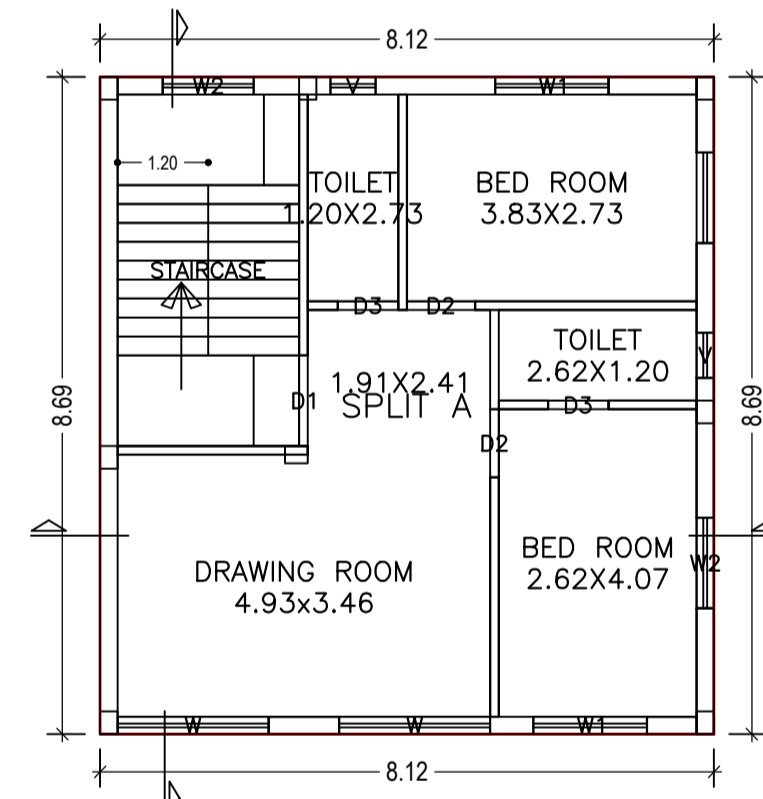
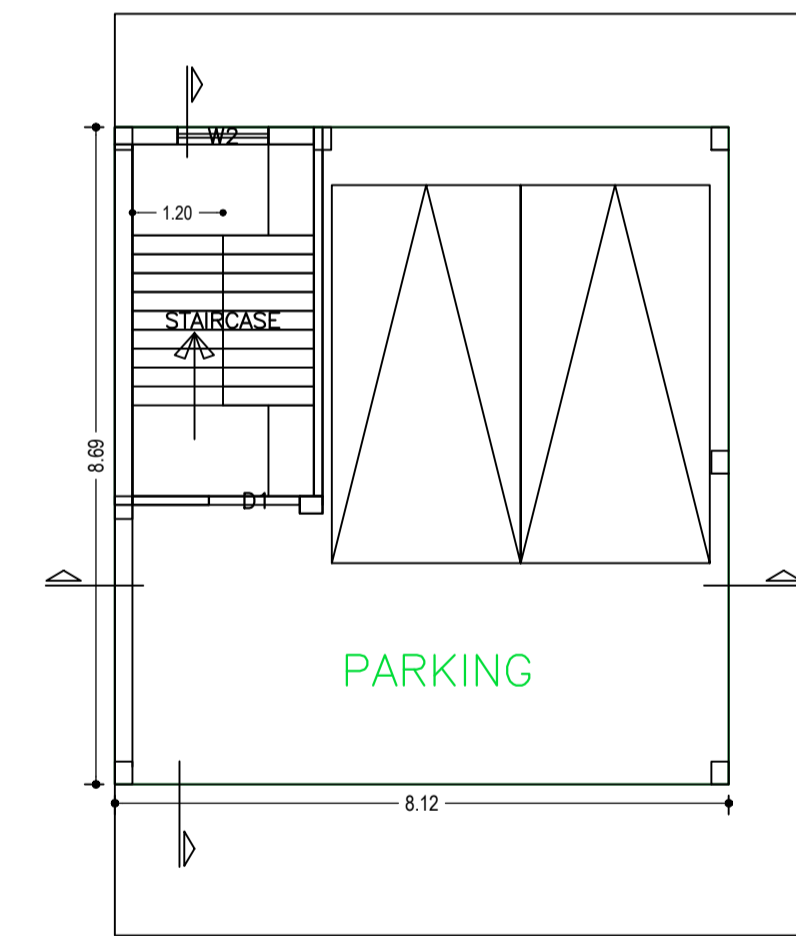

SECOND FLOOR PLAN
(Proposed)
SCALE 1:100

AREA STATEMENT		VERSION NO.: 1.0.28
JAMSHEDPUR NAC		VERSION DATE: 30/06/2018
PROJECT DETAIL:		
Region: JHARKHAND URBAN LOCAL BODIES	Plot Use: Residential	
District: EAST SINGHBHUM	Plot SubUse: Row House	
Authority: JAMSHEDPUR NAC	Plot/Nearby/Religious Structure: NA	
Inward No: JNAC/BP/0100/W11/2018	Plot/SubPlot No: 3	
Application Type: General Proposal	North: Road Width - 5.5M	
Project Type: Building Permission	South: Road Width - 6.5M	
Nature of Development: New	East: Plot No. - 4	
Location of Development Area: Old Area	West: Plot No. - 2	
AREA DETAILS:		
AREA OF PLOT (Minimum)	(A)	111.17
NET AREA OF PLOT(Gross Plot Area - Deduction from Gross Plot area)		111.17
Deduction for Balance Plot Area(from Gross Plot Area)		
Common Plot		19.33
Total		19.33
BALANCE AREA OF PLOT(Net Plot Area - Recreational/Amenity space)	(A-Deductions)	91.84
PLOT AREA FOR COVERAGE(Net Plot Area)	(A-Deductions)	111.17
Plot Area for FAR (Net Plot Area + Road/Widening Area)	(A-Deductions)	111.17
COVERAGE CHECK		
Permissible Coverage area (70.00 %)		77.82
Proposed Coverage Area (63.47 %)		70.56
Total Prop. Coverage Area (63.47 %)		70.56
Balance coverage area (6.53 %)		7.26
FAR CHECK		
Perm. FAR Area (1.80)		200.11
Total Perm. FAR area		200.11
Residential FAR		141.13
Proposed FAR Area		152.29
Total Proposed FAR Area		152.29
Consumed FAR (Factor)		1.37
Balance FAR Area		47.82
BUILT UP AREA CHECK		
Total Proposed BuiltUp Area		211.68
ARCHITECT (Regd)	Shreyashi Halder	
ENGINEER (Regd)		
SUPERVISOR (Regd)		
OWNER (Regd)	ANJU PRASAD	
DEVELOPMENT AUTHORITY		
	LOCAL BODY	

COLOR INDEX	
PLOT BOUNDARY	Black
ABUTTING ROAD	Red
PROPOSED CONSTRUCTION	Green
COMMON PLOT	Yellow
ROAD WIDENING AREA	Orange
EXISTING (To be retained)	Blue
EXISTING (To be demolished)	Light Blue

Buildingwise Floor FAR Details

Floor Name	Building Name A (ANJU PRASAD)		Total	
	Proposed Built Up Area (Sq.mt.)	Proposed FAR Area (Sq.mt.)	Total Proposed Built Up Area (Sq.mt.)	Total FAR Area (Sq.mt.)
Ground And Parking Floor	70.56	11.16	70.56	11.16
First Floor	70.56	70.56	70.56	70.56
Second Floor	70.56	70.56	70.56	70.56
Terrace Floor	0.00	0.00	0.00	0.00
Total :	211.68	152.28	211.68	152.28

Building USE/SUBUSE Details

Building Name	Building Use	Building SubUse	Building Structure
A (ANJU PRASAD)	Residential	Row House	Non-Highrise

FAR & Tenement Details (Table 4c-1)

Building	No. of Same Bldg	Total Built Up Area (Sq.mt.)	Deductions (Area in Sq.mt.)		Proposed FAR Area (Sq.mt.)	Add Area In FAR (Sq.mt.)	Total FAR Area (Sq.mt.)	Total Consumed Additional FAR Area (Sq.mt.)	Tnmt (No.)
			Parking	Resi.					
A (ANJU PRASAD)	1	211.68	59.40	141.12	11.16	152.28	152.28	01	
Grand Total :	1	211.68	59.40	141.12	11.16	152.28	152.28	01	

LTP NAME AND SIGNATURE	STRUCTURAL ENG'S NAME AND SIGNATURE	BUILDER NAME AND SIGNATURE
Shreyashi Halder JNAC/DFTM/0009/2016		

Proposal Basic Information	
Proposal File No.	JNAC/BP/0100/W11/2018
Owner Name	ANJU PRASAD
Khata No	NIL
Plot No	3
Village Name	Sitaramdera
Use	Residential
SubUse	Row House

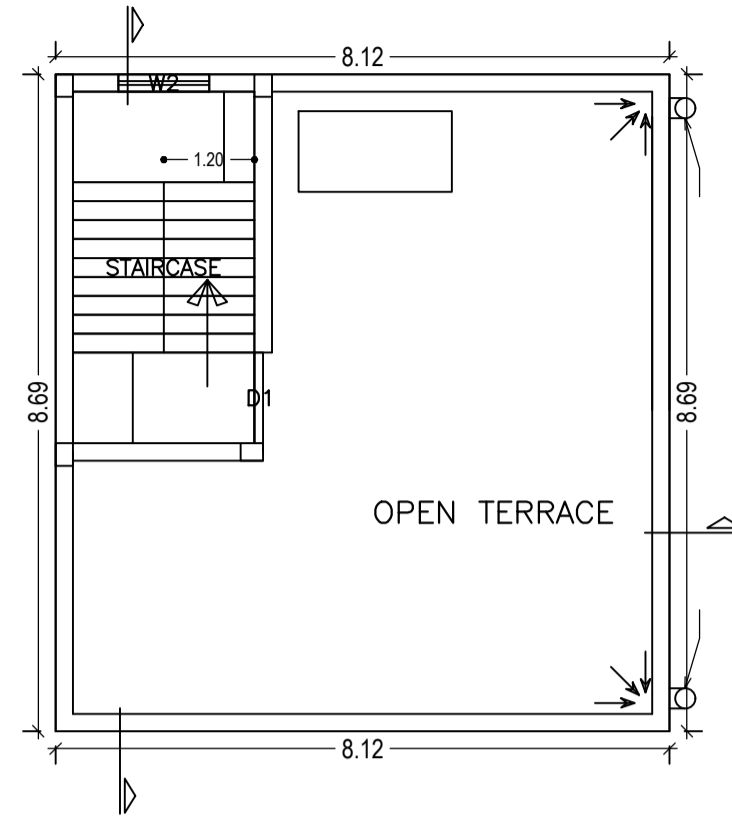

Building :A (ANJU PRASAD)

Floor Name	Total Built Up Area (Sq.mt.)	Deductions (Area in Sq.mt.)		Proposed FAR Area (Sq.mt.)		Add Area In FAR (Sq.mt.)	Total FAR Area (Sq.mt.)	Total Consumed Additional FAR Area (Sq.mt.)	Trmt (No.)
		Parking	Resi.	Stair	Stair				
Ground And Parking Floor	70.56	59.40	0.00	11.16	11.16	11.16	11.16	00	
First Floor	70.56	0.00	70.56	0.00	70.56	70.56	70.56	01	
Second Floor	70.56	0.00	70.56	0.00	70.56	70.56	70.56	00	
Terrace Floor	0.00	0.00	0.00	0.00	0.00	0.00	0.00	00	
Total :	211.68	59.40	141.12	11.16	152.28	152.28	152.28	01	
Total Number of Same Buildings :	1								
Total :	211.68	59.40	141.12	11.16	152.28	152.28	152.28	01	

TERRACE FLOOR PLAN (SCALE 1:100)

SCHEDULE OF DOOR:

BUILDING NAME	NAME	LENGTH	HEIGHT	NOS
A (ANJU PRASAD)	D3	0.80	2.10	04
A (ANJU PRASAD)	D2	0.90	2.10	06
A (ANJU PRASAD)	D1	1.20	2.10	02

SCHEDULE OF WINDOW/VENTILATION:

BUILDING NAME	NAME	LENGTH	HEIGHT	NOS
A (ANJU PRASAD)	V	0.60	0.60	04
A (ANJU PRASAD)	W3	0.90	1.20	01
A (ANJU PRASAD)	W2	1.20	1.20	06
A (ANJU PRASAD)	W1	1.50	1.20	04
A (ANJU PRASAD)	W	2.00	1.20	02

UnitBUA Table for Building :A (ANJU PRASAD)

FLOOR	Name	UnitBUA Type	UnitBUA Area	Carpet Area	No. of Rooms	No. of Tenement
FIRST FLOOR PLAN	SPLIT A	FLAT	141.13	132.21	7	1
SECOND FLOOR PLAN	SPLIT A	FLAT	0.00	0.00	5	0
Total:	-	-	141.13	132.21	12	1

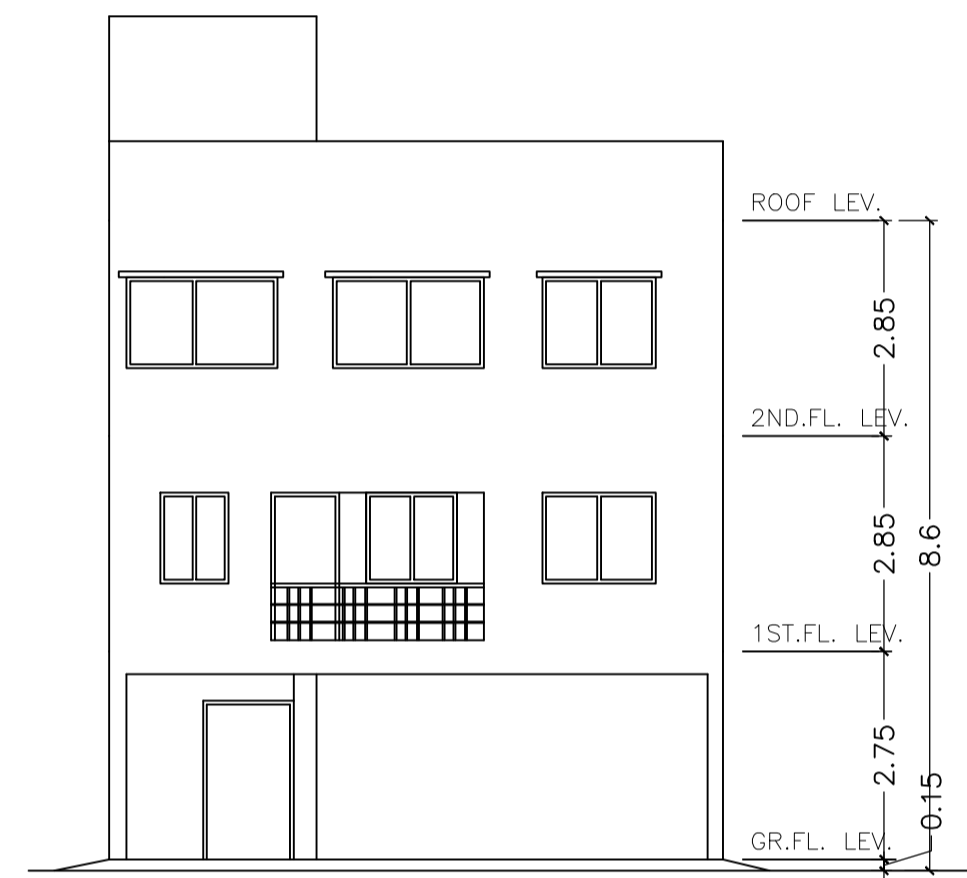

FRONT ELEVATION SCALE=1:100

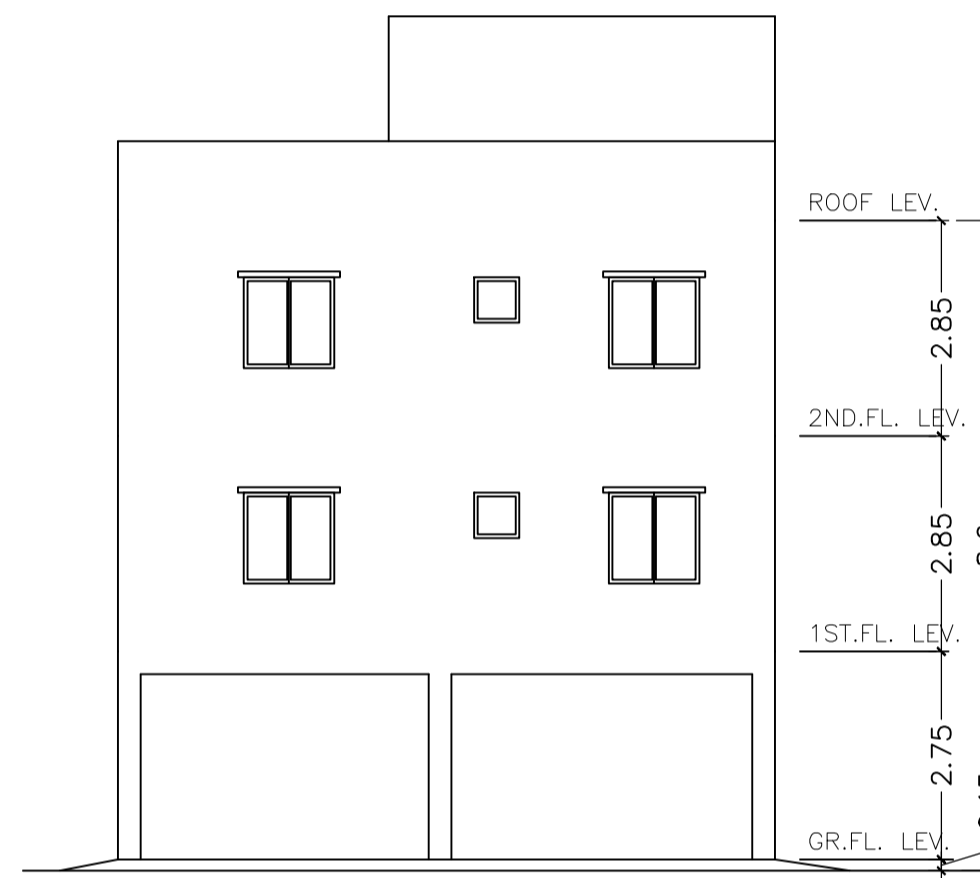

SIDE ELEVATION SCALE=1:100



RARE ELEVATION SCALE=1:100

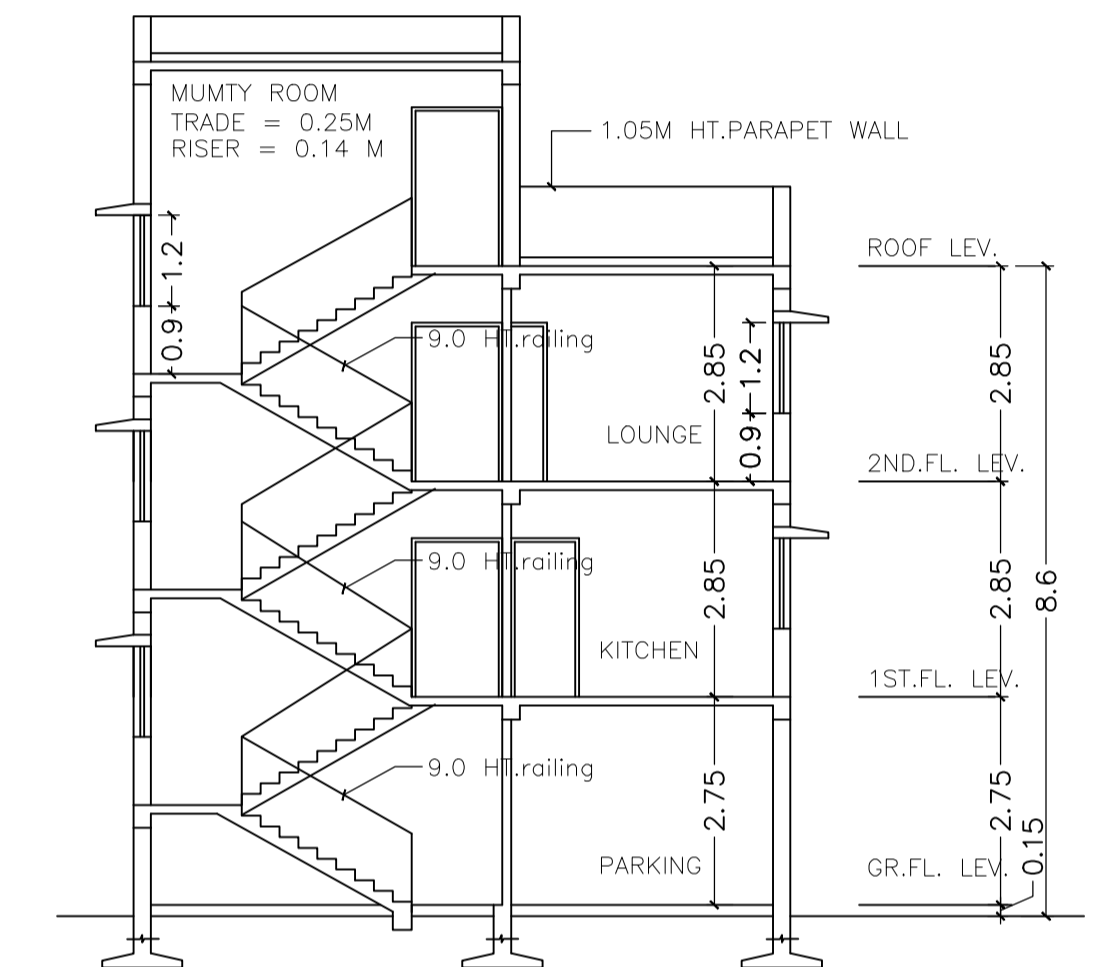

SECTION - Y-Y SCALE=1:100

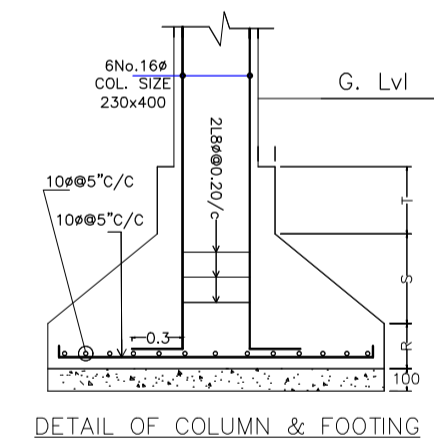

DETAIL OF COLUMN & FOOTING

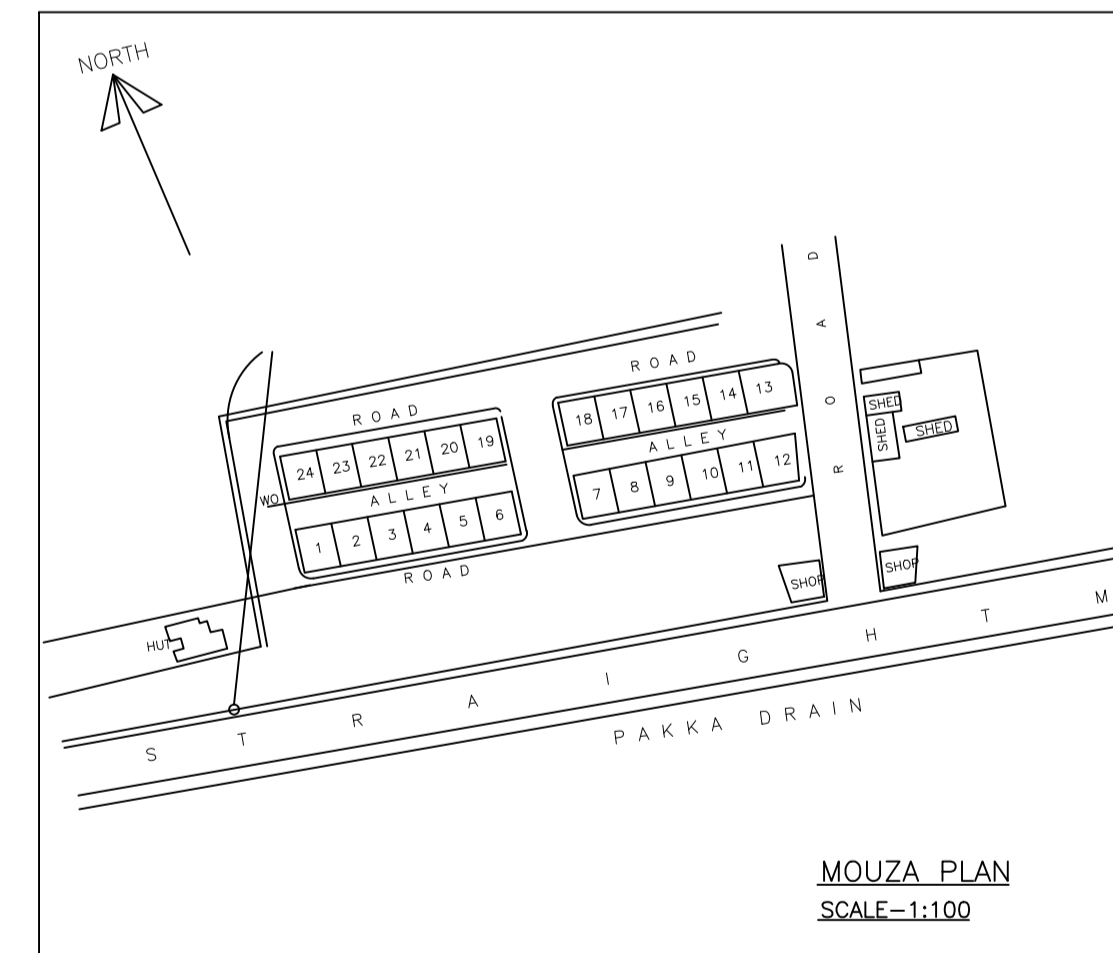

MOUZA PLAN SCALE=1:100

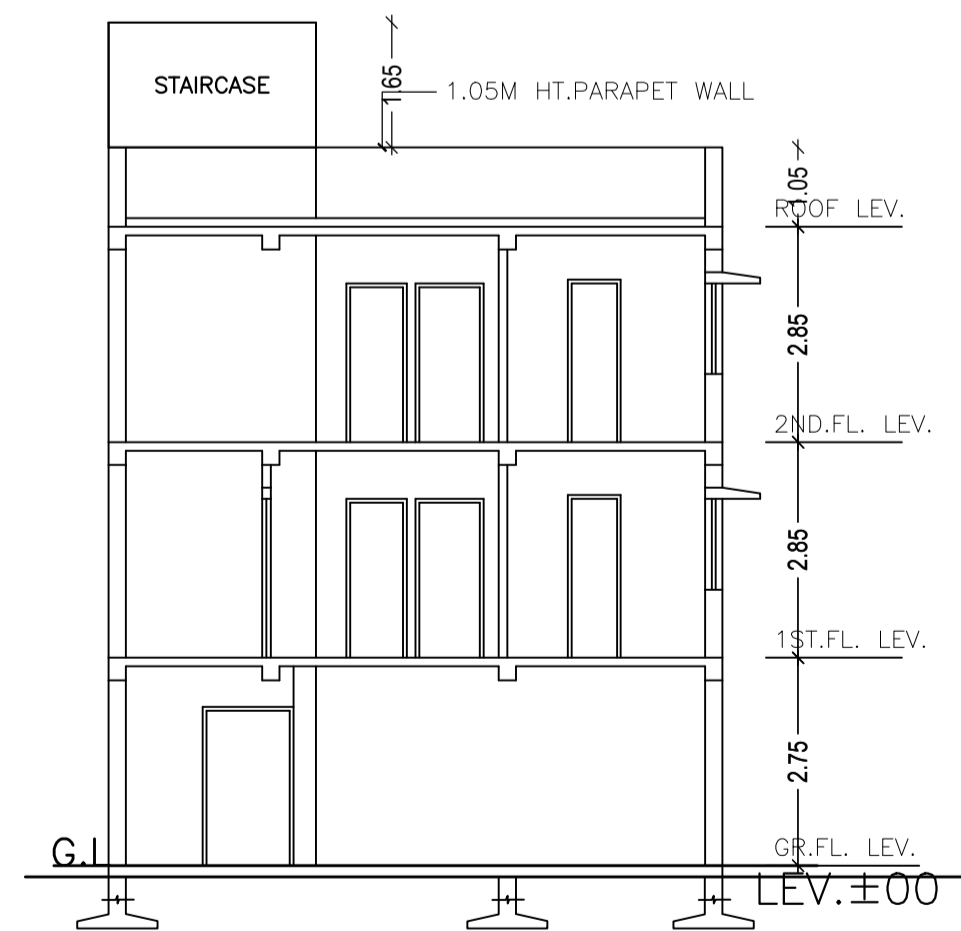

SECTION X-X SCALE=1:100

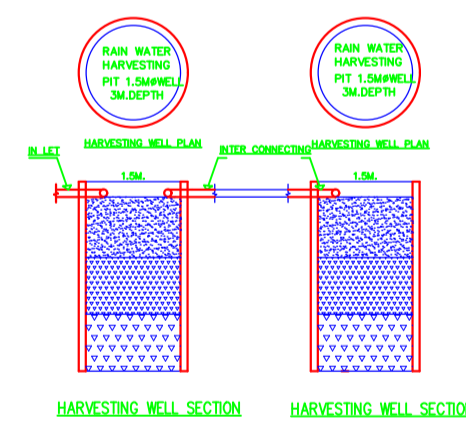

HARVESTING WELL SECTION

LTP NAME AND SIGNATURE	STRUCTURAL ENG'S NAME AND SIGNATURE	BUILDER NAME AND SIGNATURE
Shreyashi Halder JNAC/DFTM/0009/2016		