

Proposal Basic Information	
Proposal File No.	JNAC/BP/0004/W11/2018
Owner Name	Smt. Kanta Khanna and Others
Khata No	Nil
Plot No	H. No- 376-A
Village Name	Sitaramdera
Use	Residential
SubUse	Bungalow/ Dwelling / Non Apartment

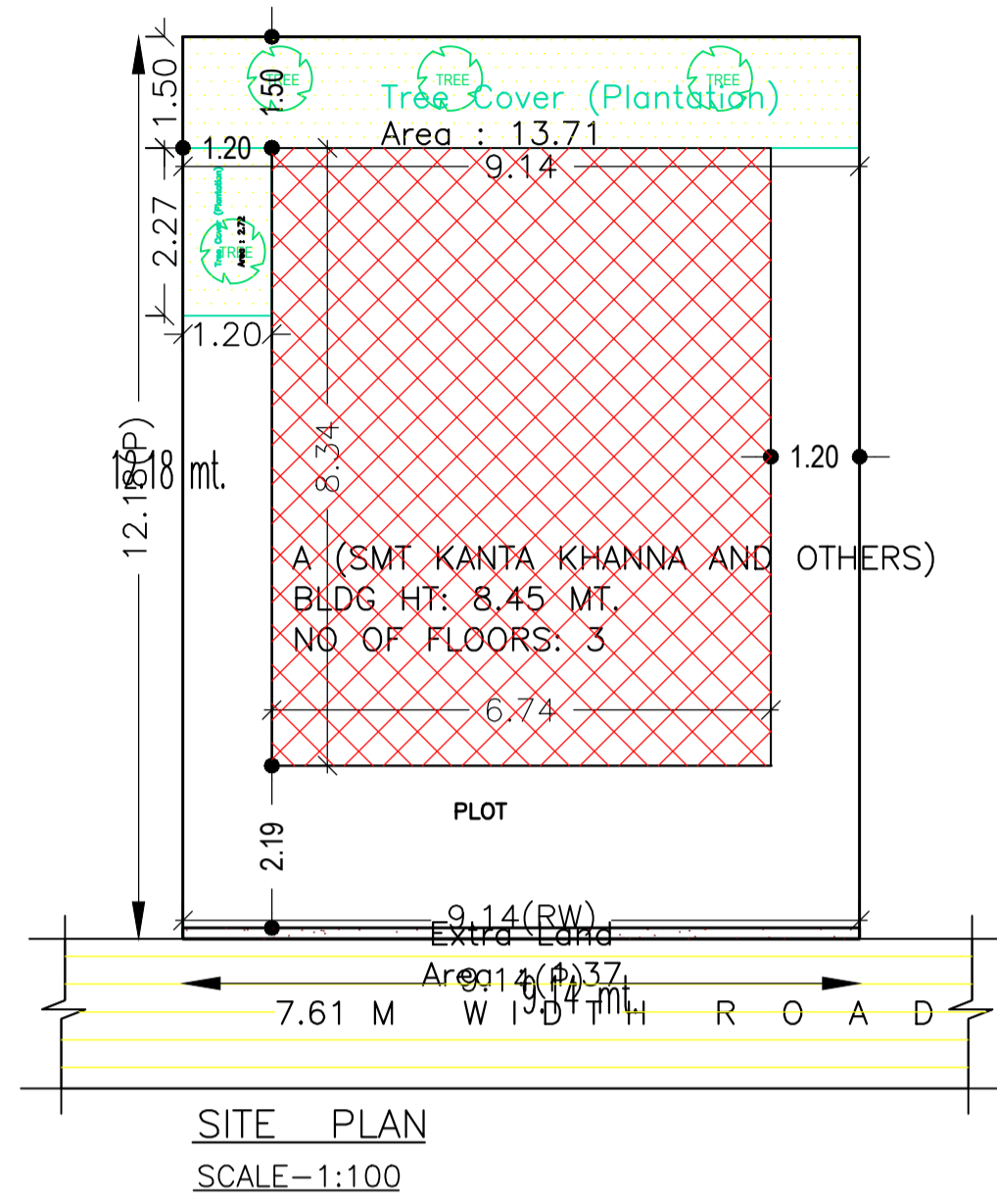

AREA STATEMENT	VERSION NO.: 1.0.27
JAMSHEDPUR NAC	VERSION DATE: 18/05/2018
PROJECT DETAIL:	
Region: JHARKHAND URBAN	Plot Use: Residential
LOCAL BODIES	Plot SubUse: Bungalow/ Dwelling / Non Apartment
District: EAST SINGHBHUM	PlotNearby/ReligiousStructure: NA
Authority: JAMSHEDPUR NAC	Plot/Plot No: H. No- 376-A
Inward No.: JNAC/BP/0004/W11/2018	North: Road Width - 7.62
Application Type: General Proposal	South: Survey No. - Alley
Project Type: Building Permission	East: Plot No. - 376-B
Nature of Development: New	West: Survey No. - Open Land (Road)
Location of Development Area: Old Area	
AREA DETAILS:	
AREA OF PLOT (Minimum)	(A) 111.33
Deduction for NetPlot Area	
Extra Land Area	1.37
Total	1.37
NET AREA OF PLOT(Gross Plot Area - Deduction from Gross Plot area)	(A-Deductions) 109.95
Deduction for Balance Plot Area(from Gross Plot Area)	
Extra Land Area	1.37
Common Plot	16.43
Total	17.80
BALANCE AREA OF PLOT(Net Plot Area - Recreational/Amenity space)	(A-Deductions) 93.53
PLOT AREA FOR COVERAGE(Net Plot Area)	(A-Deductions) 109.95
Plot Area for FAR (Net Plot Area + RoadWidening Area)	(A-Deductions) 109.95
COVERAGE CHECK	
Permissible Coverage area (70.00 %)	76.97
Proposed Coverage Area (51.12 %)	56.21
Total Prop. Coverage Area (51.12 %)	56.21
Balance coverage area (18.88 %)	20.76
FAR CHECK	
Perm. FAR Area (2.50)	274.89
Total Perm. FAR area	274.89
Residential FAR	112.42
Proposed FAR Area	124.66
Total Proposed FAR Area	124.66
Consumed FAR (Factor)	1.13
Balance FAR Area	150.23
BUILT UP AREA CHECK	
Total Proposed BuiltUp Area	168.63
ARCHITECT (Regd)	L. K Suman
ENGINEER (Regd)	
SUPERVISOR (Regd)	
OWNER (Regd)	Smt. Kanta Khanna and Others
DEVELOPMENT AUTHORITY	LOCAL BODY

COLOR INDEX	
PLOT BOUNDARY	[Red Line]
ABUTTING ROAD	[Green Line]
PROPOSED CONSTRUCTION	[Yellow Line]
COMMON PLOT	[Blue Line]
ROAD WIDENING AREA	[Orange Line]
EXISTING (To be retained)	[Black Line]
EXISTING (To be demolished)	[Grey Line]

Buildingwise Floor FAR Details

Floor Name	Building Name		Total	
	A (SMT KANTA KHANNA AND OTHERS)		Total Proposed Built Up Area (Sq.mt.)	Total FAR Area (Sq.mt.)
Ground Floor	56.21	12.24	56.21	12.24
First Floor	56.21	56.21	56.21	56.21
Second Floor	56.21	56.21	56.21	56.21
Terrace Floor	0.00	0.00	0.00	0.00
Total :	168.63	124.66	168.63	124.66

Building USE/SUBUSE Details

Building Name	Building Use	Building SubUse	Building Structure
A (SMT KANTA KHANNA AND OTHERS)	Residential	Bungalow/ Dwelling / Non Apartment	Non-Highrise

FAR & Tenement Details (Table 4c-1)

Building	No. of Same Bldg	Total Built Up Area (Sq.mt.)	Deductions (Area in Sq.mt.)		Proposed FAR Area (Sq.mt.)	Add Area In FAR (Sq.mt.)	Total FAR Area (Sq.mt.)	Total Consumed Additional FAR Area (Sq.mt.)	Tnmt (No.)
			Accessory Use	Parking					
A (SMT KANTA KHANNA AND OTHERS)	1	168.63	3.00	40.97	112.42	12.24	124.66	124.66	01
Grand Total :	1	168.63	3.00	40.97	112.42	12.24	124.66	124.66	01

LTP NAME AND SIGNATURE	STRUCTURAL ENG'S NAME AND SIGNATURE	BUILDER NAME AND SIGNATURE
L. K Suman JNAC/ENG/0006/2016		

Proposal Basic Information	
Proposal File No.	JNAC/BP/0004/W11/2018
Owner Name	Smt. Kanta Khanna and Others
Khata No	Nil
Plot No	H. No- 376-A
Village Name	Sitaramdera
Use	Residential
SubUse	Bungalow/ Dwelling / Non Apartment

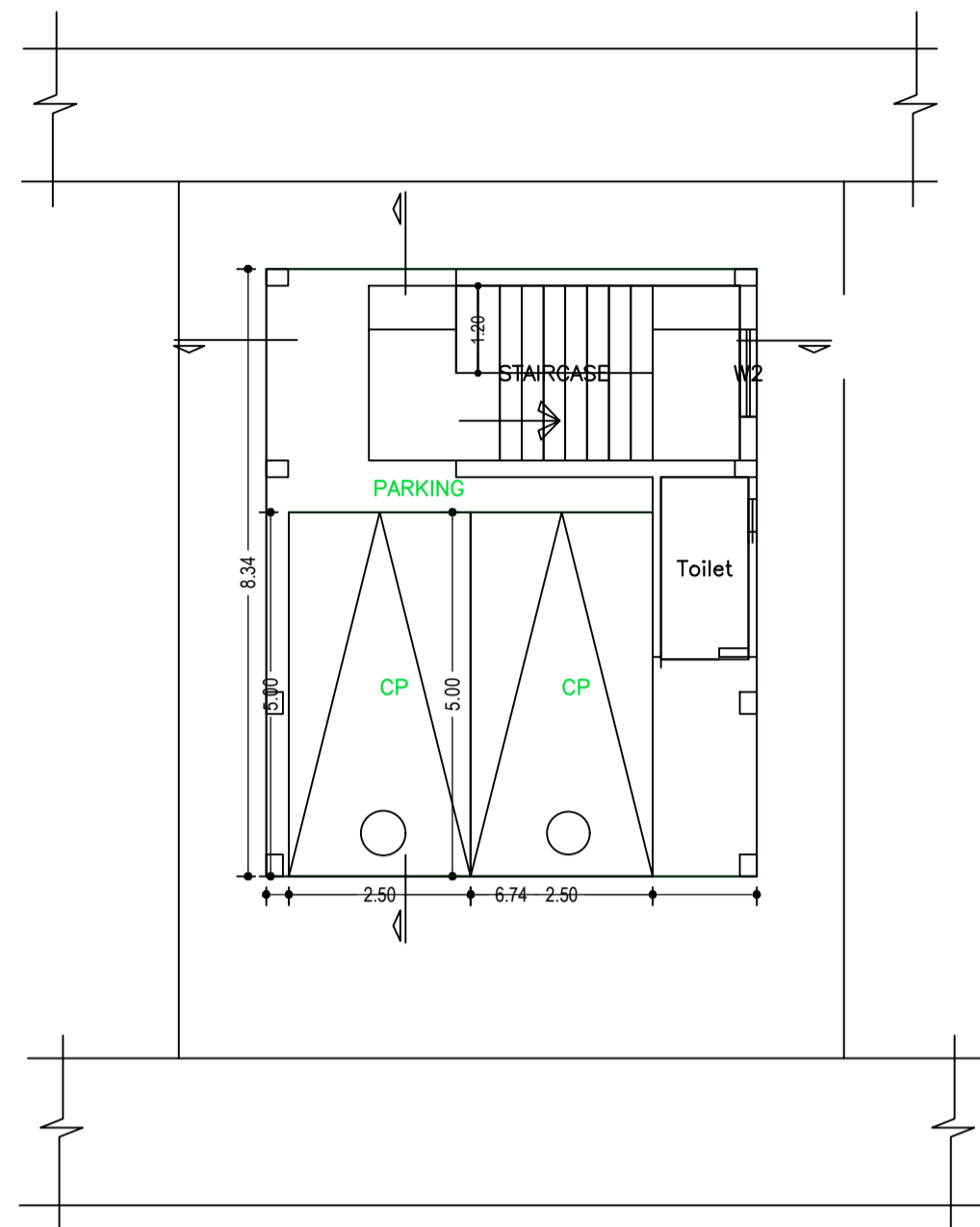

GROUND FLOOR PLAN
(SCALE 1:100)

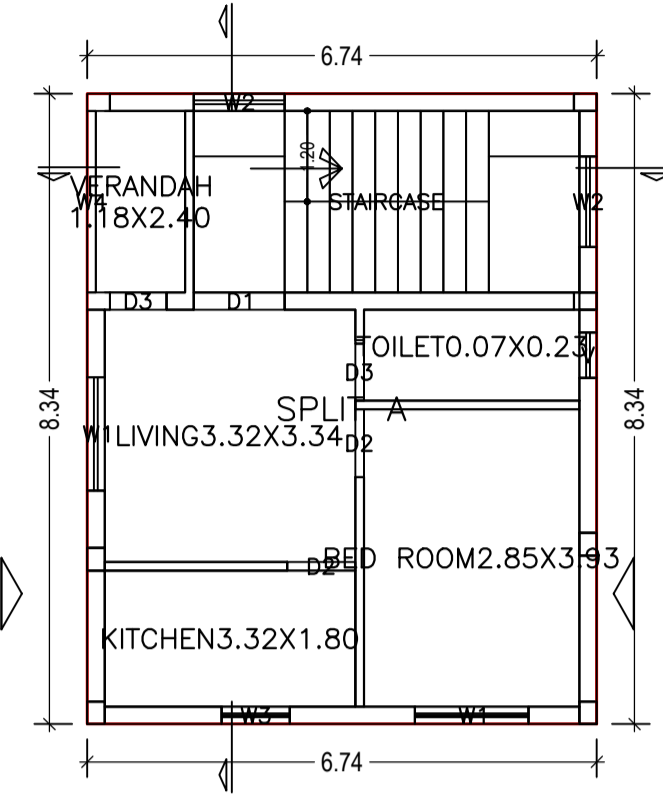

FIRST FLOOR PLAN
(Proposed)
(SCALE 1:100)

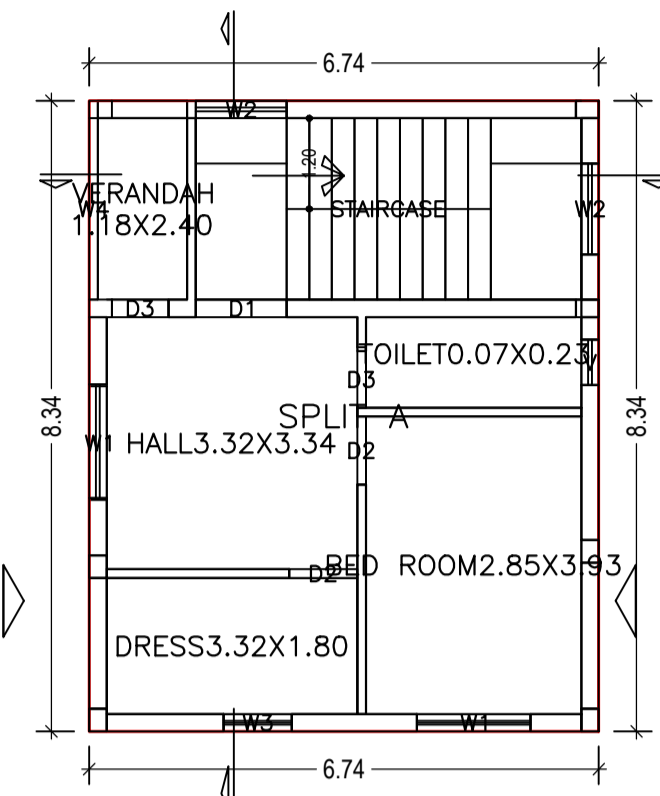

SECOND FLOOR PLAN
(Proposed)
(SCALE 1:100)

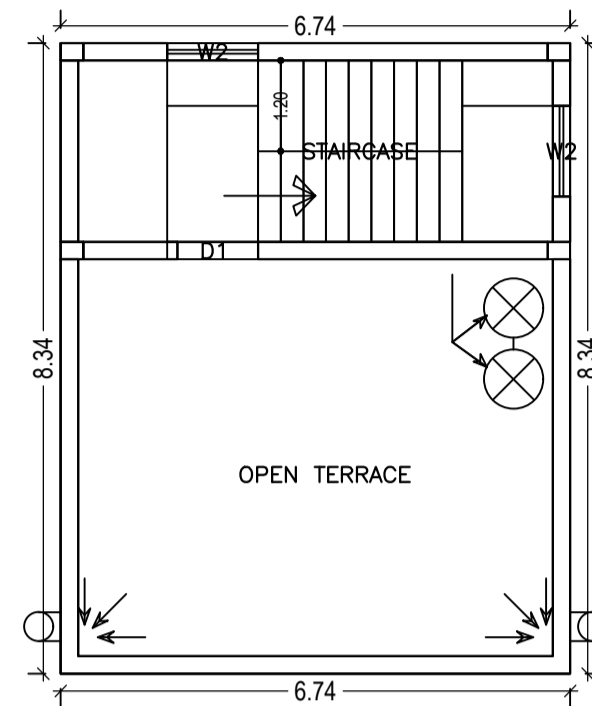

TERRACE FLOOR PLAN
(SCALE 1:100)

Building :A (SMT KANTA KHANNA AND OTHERS)

Floor Name	Total Built Up Area (Sq.mt.)	Deductions (Area in Sq.mt.)		Proposed FAR Area (Sq.mt.)	Add Area In FAR (Sq.mt.)	Total FAR Area (Sq.mt.)	Total Consumed Additional FAR Area (Sq.mt.)	Trmt (No.)
		Accessory Use	Parking					
Ground Floor	56.21	3.00	40.97	0.00	12.24	12.24	12.24	00
First Floor	56.21	0.00	0.00	56.21	0.00	56.21	56.21	01
Second Floor	56.21	0.00	0.00	56.21	0.00	56.21	56.21	00
Terrace Floor	0.00	0.00	0.00	0.00	0.00	0.00	0.00	00
Total :	168.63	3.00	40.97	112.42	12.24	124.66	124.66	01
Total Number of Same Buildings :	1							
Total :	168.63	3.00	40.97	112.42	12.24	124.66	124.66	01

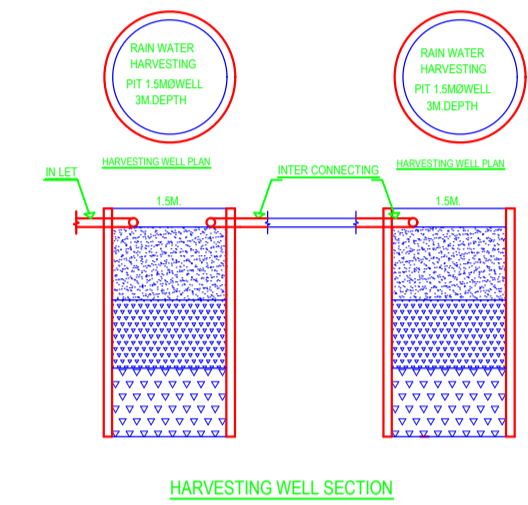

HARVESTING WELL SECTION

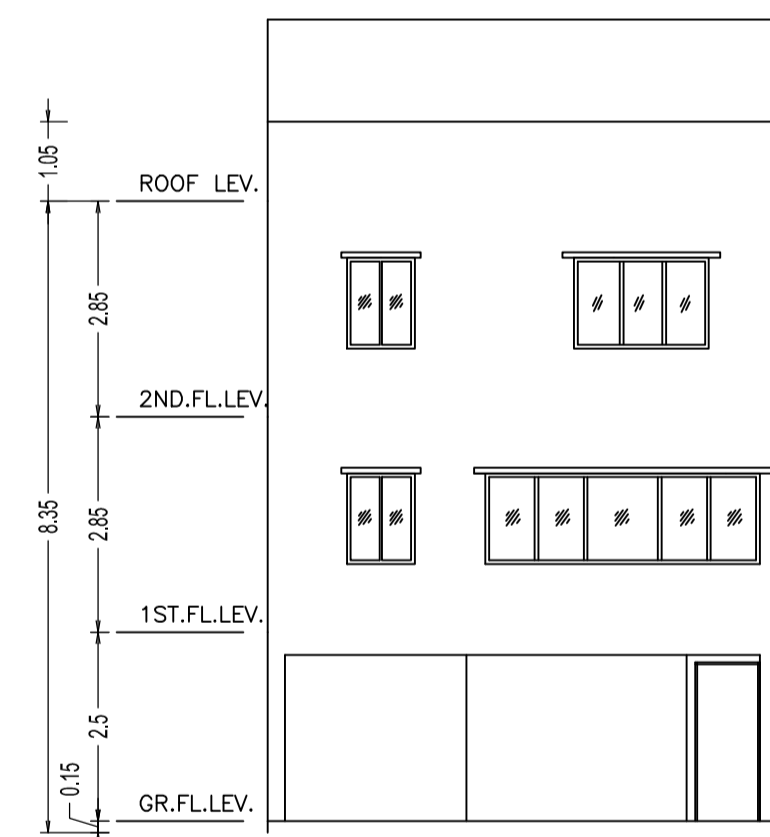

FRONT ELEVATION
SCALE-1:100

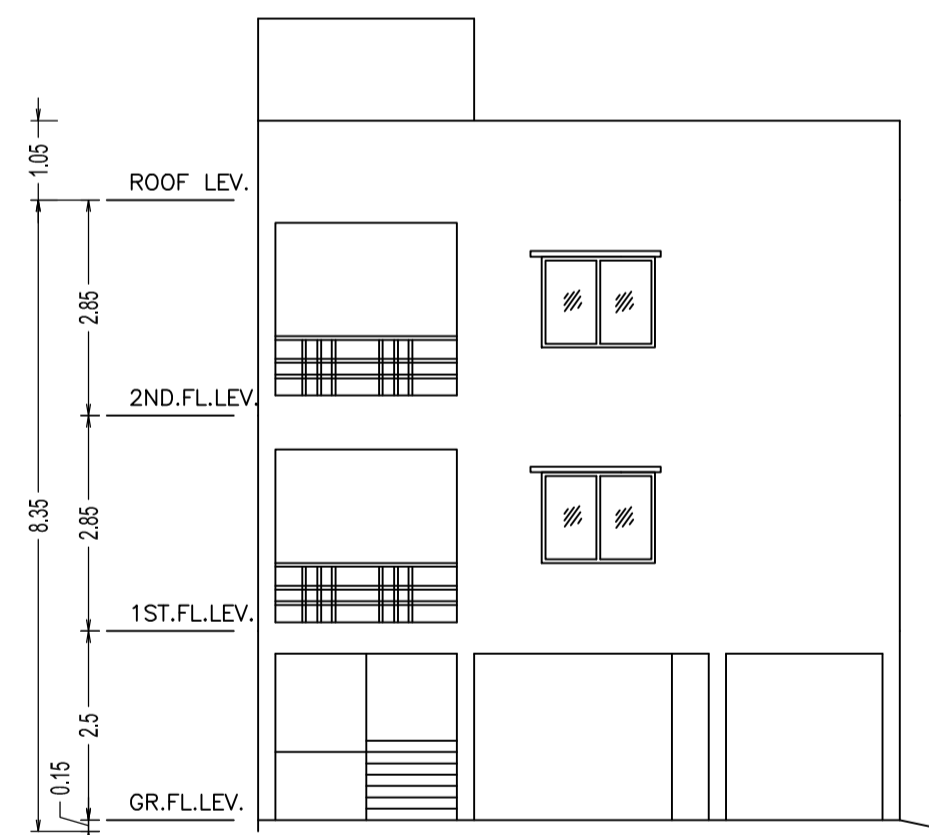

SIDE - A ELEVATION
SCALE-1:100

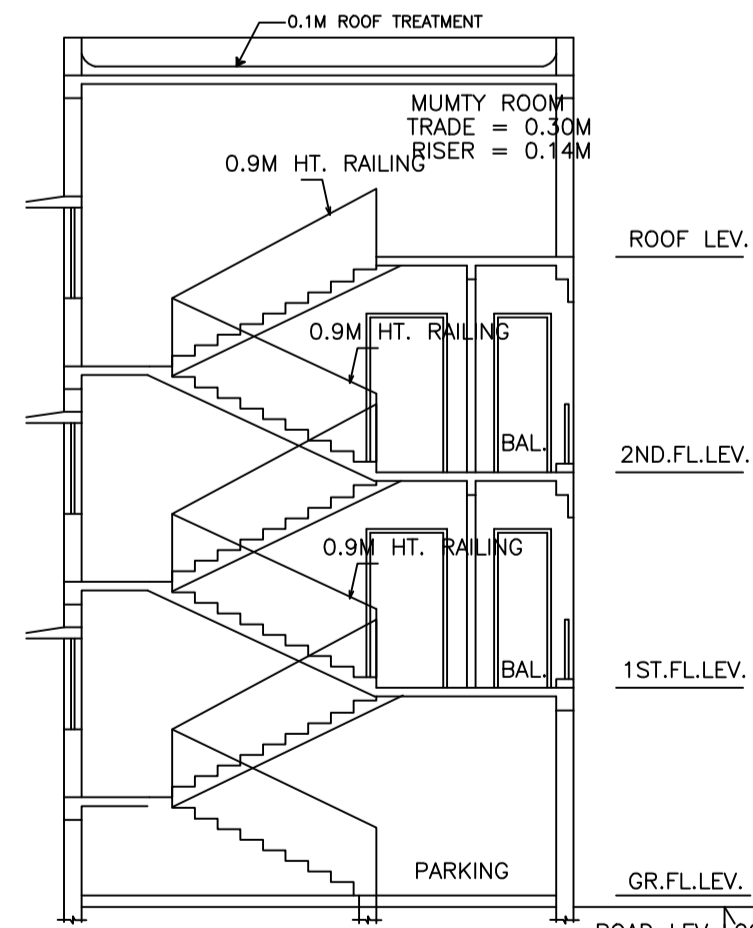

SCALE-1:100

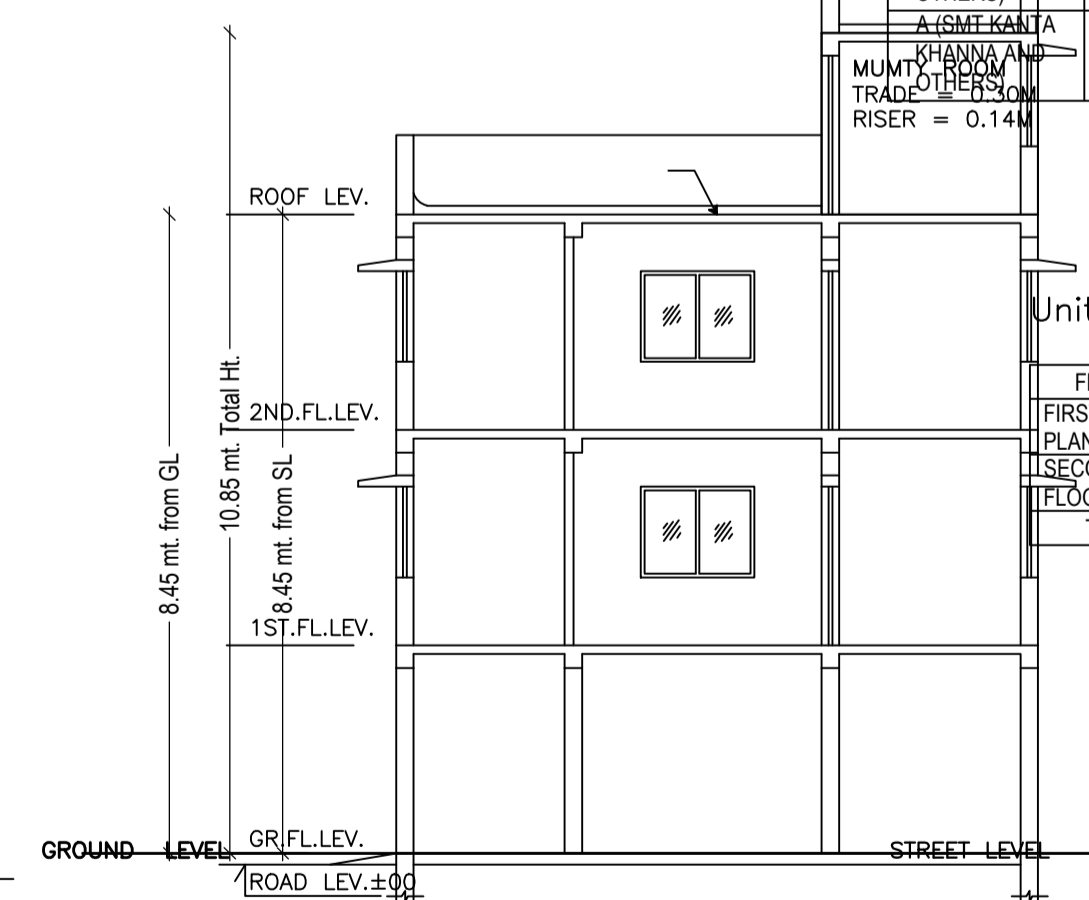

SECTION - Y-Y
SCALE-1:100

SCHEDULE OF DOOR:

BUILDING NAME	NAME	LENGTH	HEIGHT	NOS
A (SMT KANTA KHANNA AND OTHERS)	D3	0.75	2.10	04
A (SMT KANTA KHANNA AND OTHERS)	D2	0.90	2.10	04
A (SMT KANTA KHANNA AND OTHERS)	D1	1.20	2.10	02

SCHEDULE OF WINDOW/VENTILATION:

BUILDING NAME	NAME	LENGTH	HEIGHT	NOS
A (SMT KANTA KHANNA AND OTHERS)	V	0.60	0.60	02
A (SMT KANTA KHANNA AND OTHERS)	W3	0.90	1.20	02
A (SMT KANTA KHANNA AND OTHERS)	W2	1.20	1.20	07
A (SMT KANTA KHANNA AND OTHERS)	W1	1.50	1.20	04
A (SMT KANTA KHANNA AND OTHERS)	W4	2.40	1.20	02

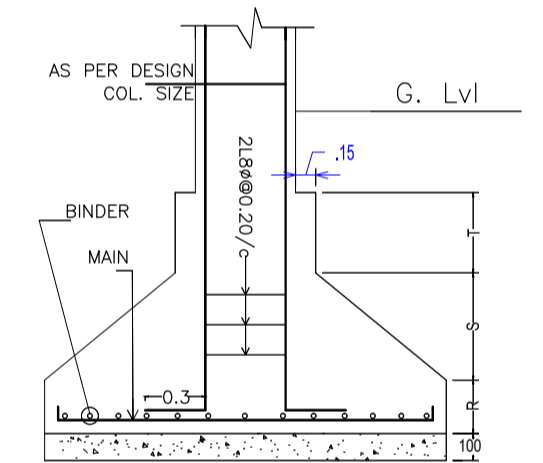

DETAIL OF COLUMN & FOOTING

UnitBUA Table for Building :A (SMT KANTA KHANNA AND OTHERS)

FLOOR	Name	UnitBUA Type	UnitBUA Area	Carpet Area	No. of Rooms	No. of Tenement
FIRST FLOOR PLAN	SPLIT A	FLAT	99.58	95.06	5	1
SECOND FLOOR PLAN	SPLIT A	FLAT	0.00	0.00	5	0
TERRACE FLOOR PLAN	-	-	99.58	95.06	10	1

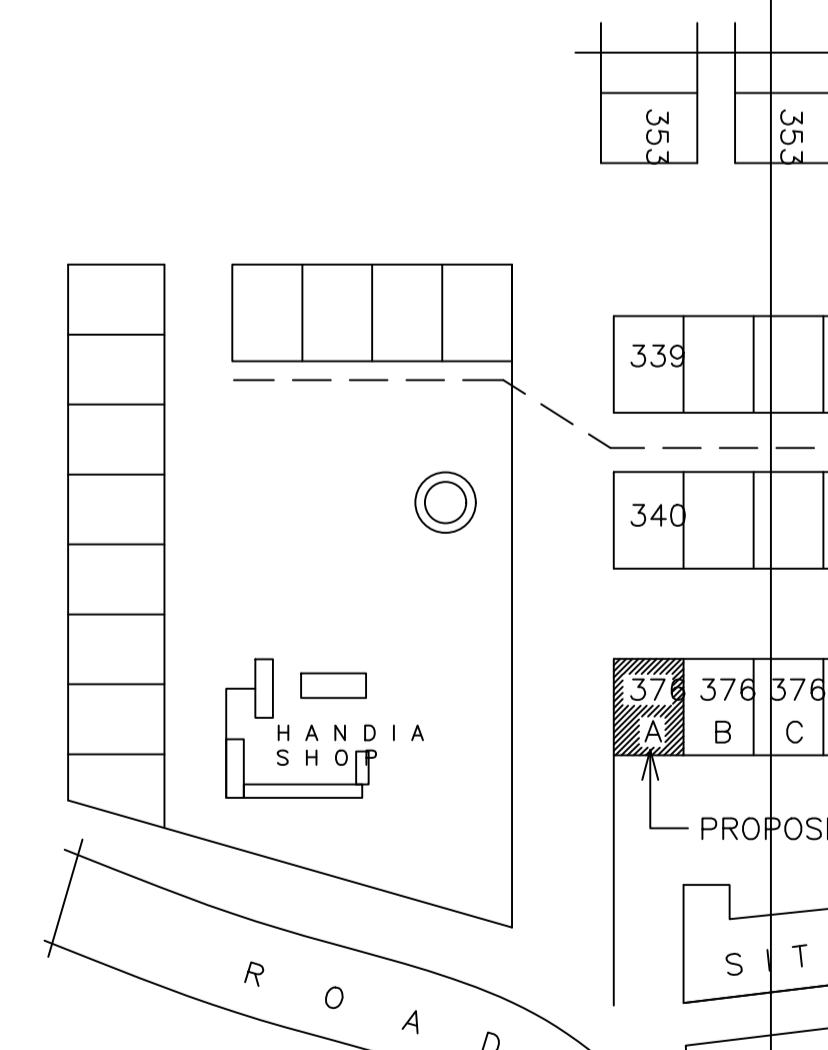

LTP NAME AND SIGNATURE	STRUCTURAL ENG'S NAME AND SIGNATURE	BUILDER NAME AND SIGNATURE
L K Suman JNAC/ENG/0006/2016		

MOUZA PLAN
NOT TO SCALE