

Proposal Basic Information

Proposal File No.	JNAC/BP/0022/W7/2018
Owner Name	SRI BINAY KUMAR SAHU
Khata No	NIL
Plot No	NIL
Village Name	SAKCHI
Use	Residential
SubUse	Bungalow/ Dwelling / Non Apartment

Building USE/SUBUSE Details

Building Name	Building Use	Building SubUse	Building Structure
A (SRI BINAY KUMAR SAHU)	Residential	Residential Bldg/Apartment	Non-Highrise

FAR & Tenement Details (Table 4c-1)

Building	No. of Same Bldg	Total Built Up Area (Sq.mt.)	Deductions (Area in Sq.mt.)			Proposed FAR Area (Sq.mt.)	Add Area In FAR (Sq.mt.)	Total FAR Area (Sq.mt.)	Total Consumed Additional FAR Area (Sq.mt.)	Tnmt (No.)
			Parking	Resi.	Stair					
A (SRI BINAY KUMAR SAHU)	1	268.04	77.67	179.21	11.16	190.37	190.37	01		
Grand Total :	1	268.04	77.67	179.21	11.16	190.37	190.37	01		

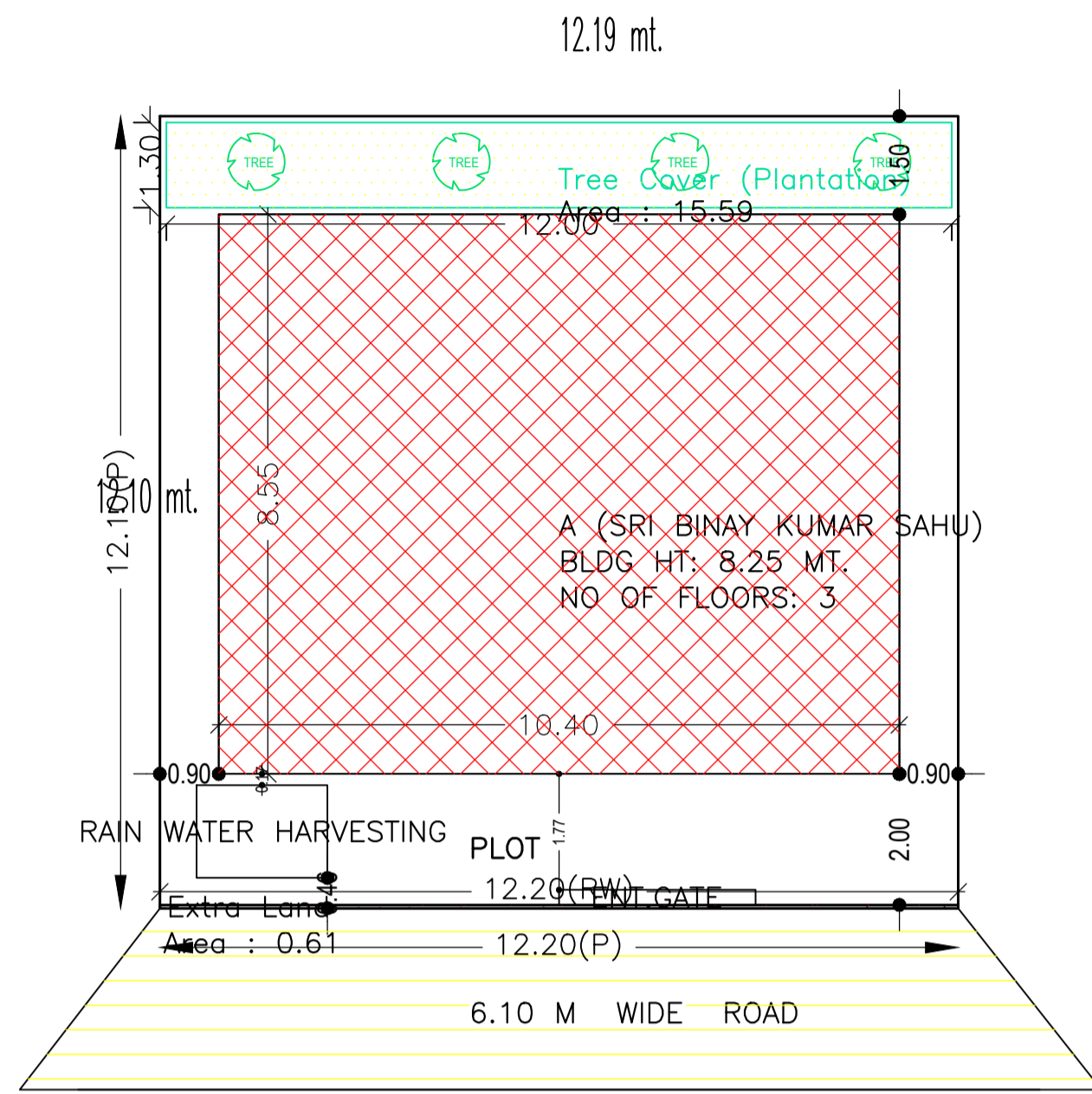

SITE PLAN
SCALE : 1:100

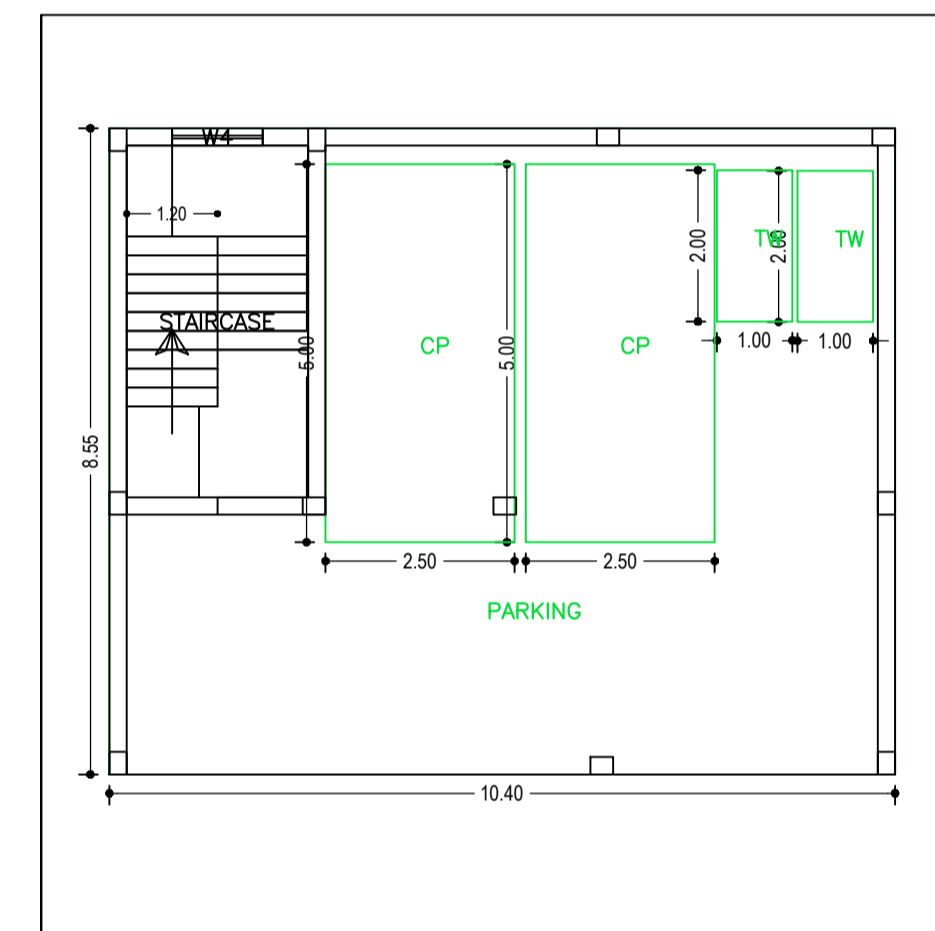

GROUND FLOOR PLAN
(SCALE 1:100)

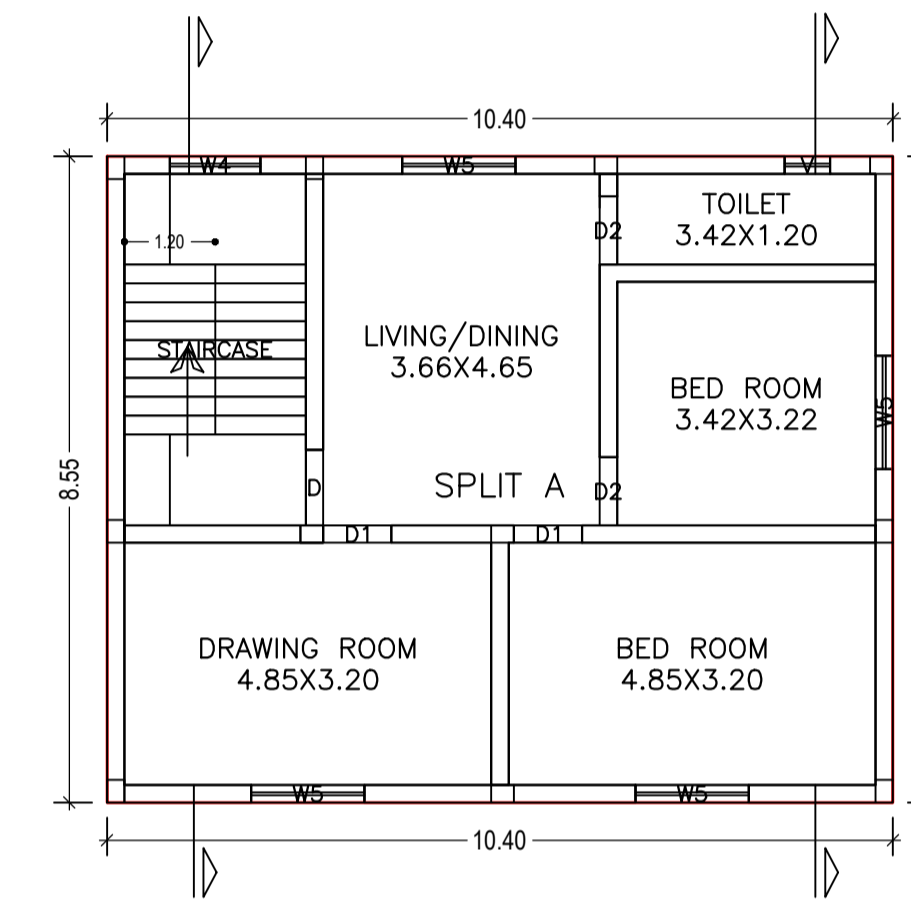

SECOND FLOOR PLAN
(Proposed)
(SCALE 1:100)

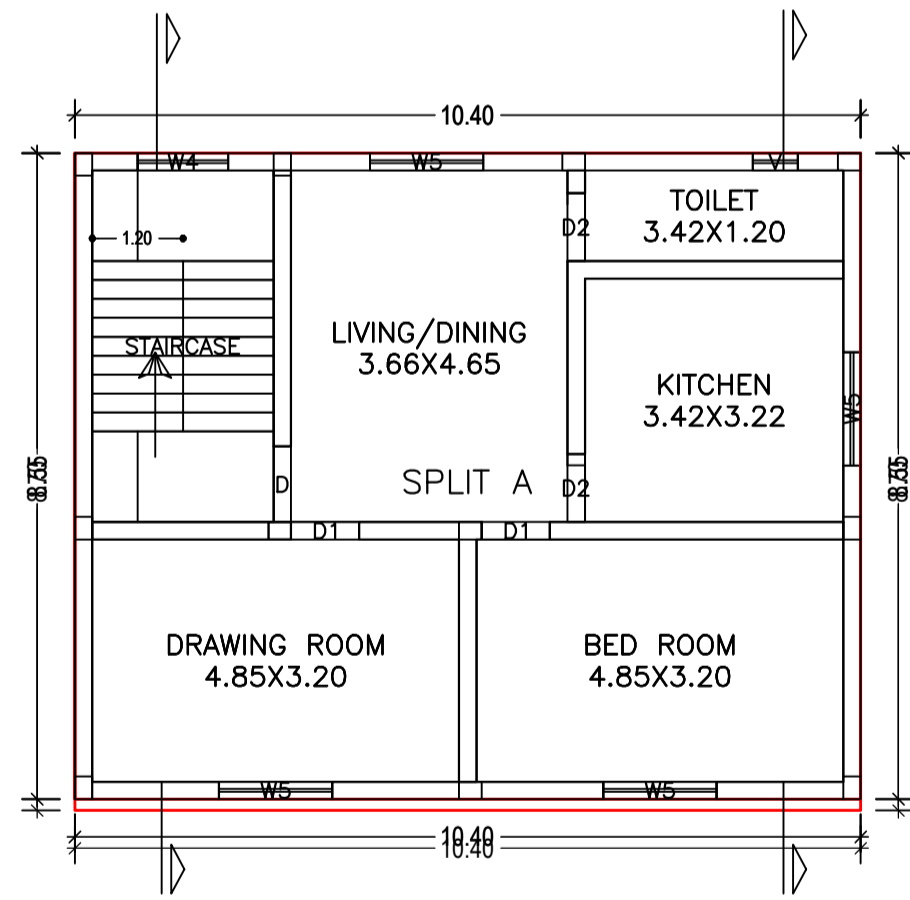

FIRST FLOOR PLAN
(Proposed)
(SCALE 1:100)

Building :A (SRI BINAY KUMAR SAHU)

Floor Name	Total Built Up Area (Sq.mt.)	Deductions (Area in Sq.mt.)			Proposed FAR Area (Sq.mt.)	Add Area In FAR (Sq.mt.)	Total FAR Area (Sq.mt.)	Total Consumed Additional FAR Area (Sq.mt.)	Tnmt (No.)
		Parking	Resi.	Stair					
Ground Floor	88.83	77.67	0.00	11.16	11.16	11.16	0.00	00	
First Floor	90.38	0.00	90.38	0.00	90.38	90.38	0.00	01	
Second Floor	88.83	0.00	88.83	0.00	88.83	88.83	0.00	00	
Terrace Floor	0.00	0.00	0.00	0.00	0.00	0.00	0.00	00	
Total :	268.04	77.67	179.21	11.16	190.37	190.37	01		
Total Number of Same Buildings :	1								
Total :	268.04	77.67	179.21	11.16	190.37	190.37	01		

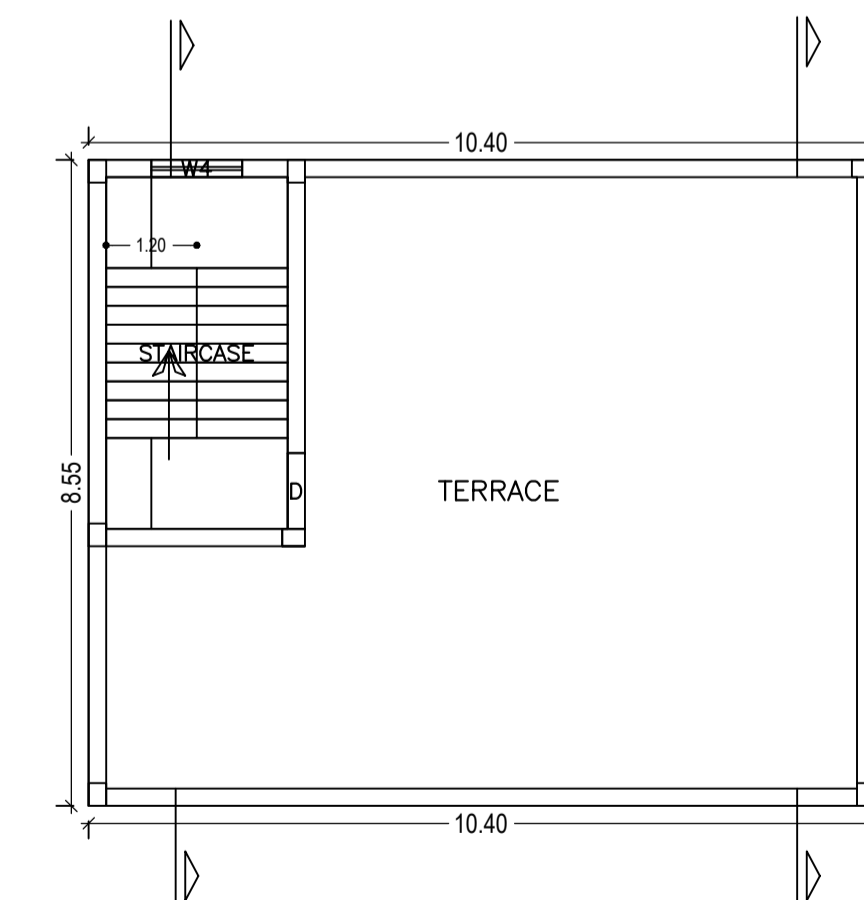

TERRACE FLOOR PLAN
(SCALE 1:100)

AREA STATEMENT		VERSION NO. : 1.0.28
JAMSHEDPUR NAC		VERSION DATE: 30/06/2018
PROJECT DETAIL:		
Region : JHARKHAND URBAN LOCAL BODIES	Plot Use: Residential	
District: EAST SINGHBHUM	Plot SubUse: Bungalow/ Dwelling / Non Apartment	
Authority: JAMSHEDPUR NAC	PlotNearby/ReligiousStructure: NA	
Inward_No : JNAC/BP/0022/W7/2018	Plot/SubPlot No: NIL	
Application Type: General Proposal	North: Plot No. - 200	
Project Type: Building Permission	South: Plot No. - 198	
Nature of Development: New	East: Survey No. - ALLEY	
Location of Development Area: Old Area	West: Road Width - 6.1	
AREA DETAILS:		
AREA OF PLOT (Minimum)	(A)	147.50
Deduction for NetPlot Area		
Extra Land Area		0.61
Total		0.61
NET AREA OF PLOT(Gross Plot Area - Deduction from Gross Plot area)	(A-Deductions)	146.89
Deduction for Balance Plot Area(from Gross Plot Area)		
Extra Land Area		0.61
Common Plot		15.59
Total		16.20
BALANCE AREA OF PLOT(Net Plot Area - Recreational/Amenity space)	(A-Deductions)	131.30
PLOT AREA FOR COVERAGE(Net Plot Area)	(A-Deductions)	146.89
Plot Area for FAR (Net Plot Area + RoadWidening Area)	(A-Deductions)	146.89
COVERAGE CHECK		
Permissible Coverage area (70.00 %)		102.82
Proposed Coverage Area (60.47 %)		88.83
Total Prop. Coverage Area (60.47 %)		88.83
Balance coverage area (9.52 %)		13.99
FAR CHECK		
Perm. FAR Area (2.50)		367.23
Total Perm. FAR area		367.23
Residential FAR		179.21
Proposed FAR Area		190.37
Total Proposed FAR Area		190.37
Consumed FAR (Factor)		1.30
Balance FAR Area		176.86
BUILT UP AREA CHECK		
Total Proposed BuiltUp Area		268.04
ARCHITECT (Regd)	L K Suman	
ENGINEER (Regd)		
SUPERVISOR (Regd)		
OWNER (Regd)	SRI BINAY KUMAR SAHU	
DEVELOPMENT AUTHORITY		LOCAL BODY

COLOR INDEX	
PLOT BOUNDARY	Black
ABUTTING ROAD	Red
PROPOSED CONSTRUCTION	Green
COMMON PLOT	Yellow
ROAD WIDENING AREA	Blue
EXISTING (To be retained)	Orange
EXISTING (To be demolished)	Grey

Buildingwise Floor FAR Details

Floor Name	Building Name		Total	
	A (SRI BINAY KUMAR SAHU)	Total	Total Proposed Built Up Area (Sq.mt.)	Total FAR Area (Sq.mt.)
Ground Floor	88.83	11.16	88.83	11.16
First Floor	90.38	0.00	90.38	90.38
Second Floor	88.83	0.00	88.83	88.83
Terrace Floor	0.00	0.00	0.00	0.00
Total :	268.04	190.37	268.04	190.37

LTP NAME AND SIGNATURE	STRUCTURAL ENG'S NAME AND SIGNATURE	BUILDER NAME AND SIGNATURE
L K Suman JNAC/ENG/0006/2016		

Proposal Basic Information

Proposal File No.	JNAC/BP/0022/W7/2018
Owner Name	SRI BINAY KUMAR SAHU
Khata No	NIL
Plot No	NIL
Village Name	SAKCHI
Use	Residential
SubUse	Bungalow/ Dwelling / Non Apartment

SCHEDULE OF DOOR:

BUILDING NAME	NAME	LENGTH	HEIGHT	NOS
A (SRI BINAY KUMAR SAHU)	D1	0.90	2.10	04
A (SRI BINAY KUMAR SAHU)	D2	0.90	2.10	04
A (SRI BINAY KUMAR SAHU)	D	1.00	2.10	02

SCHEDULE OF WINDOW/VENTILATION:

BUILDING NAME	NAME	LENGTH	HEIGHT	NOS
A (SRI BINAY KUMAR SAHU)	V	0.60	0.60	02
A (SRI BINAY KUMAR SAHU)	W4	1.20	1.20	04
A (SRI BINAY KUMAR SAHU)	W5	1.50	1.20	08

UnitBUA Table for Building :A (SRI BINAY KUMAR SAHU)

FLOOR	Name	UnitBUA Type	UnitBUA Area	Carpet Area	No. of Rooms	No. of Tenement
FIRST FLOOR PLAN	SPLIT A	FLAT	240.97	226.31	5	1
SECOND FLOOR PLAN	SPLIT A	FLAT	0.00	0.00	5	0
Total:	-	-	240.97	226.31	15	1

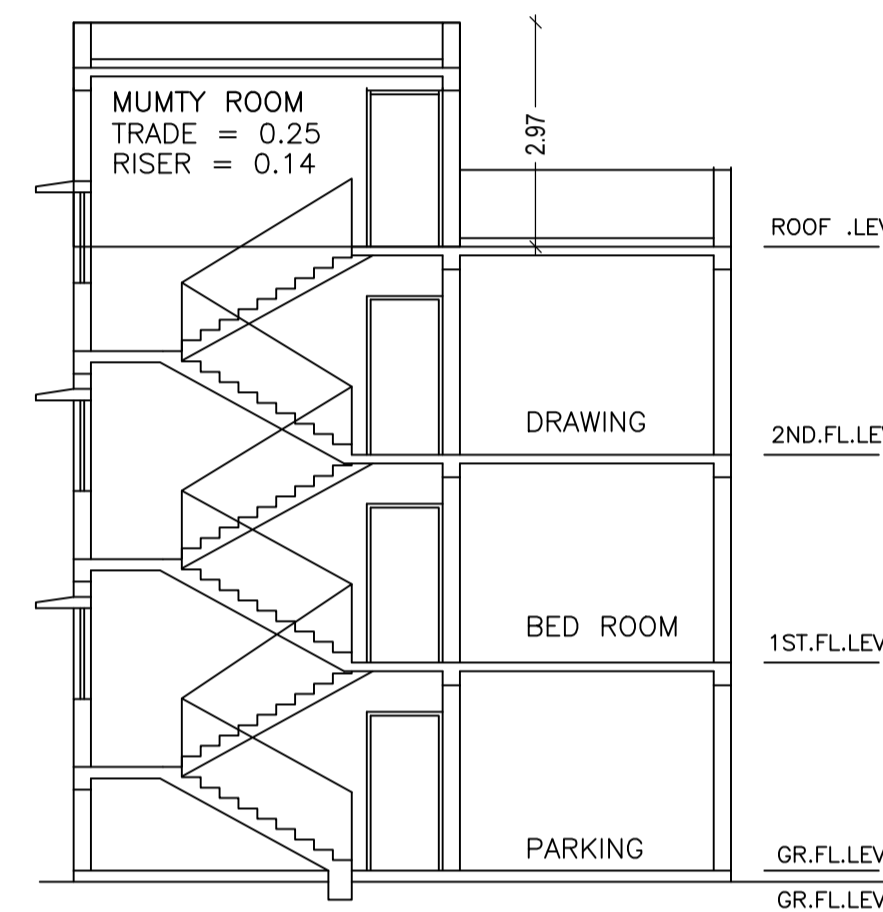
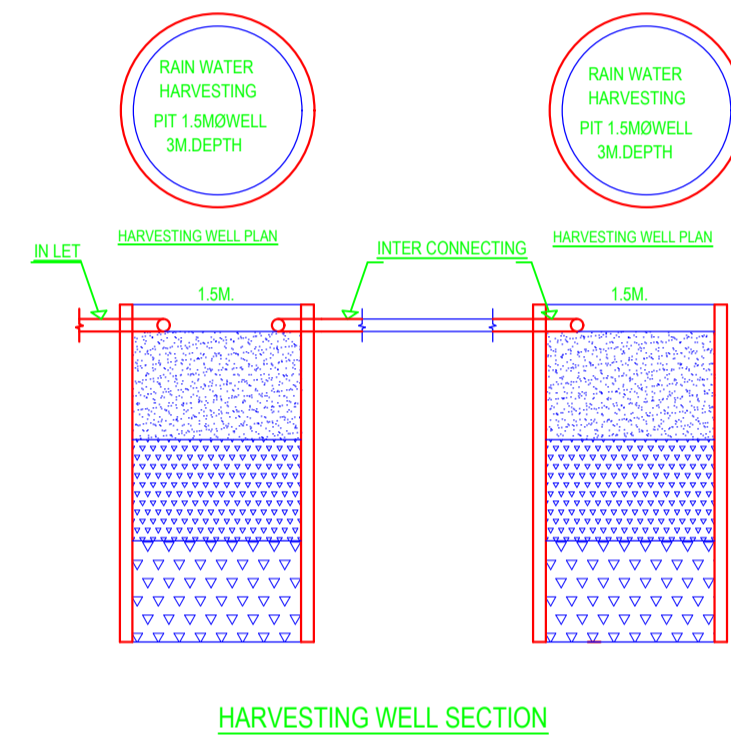

SCALE : 1:100

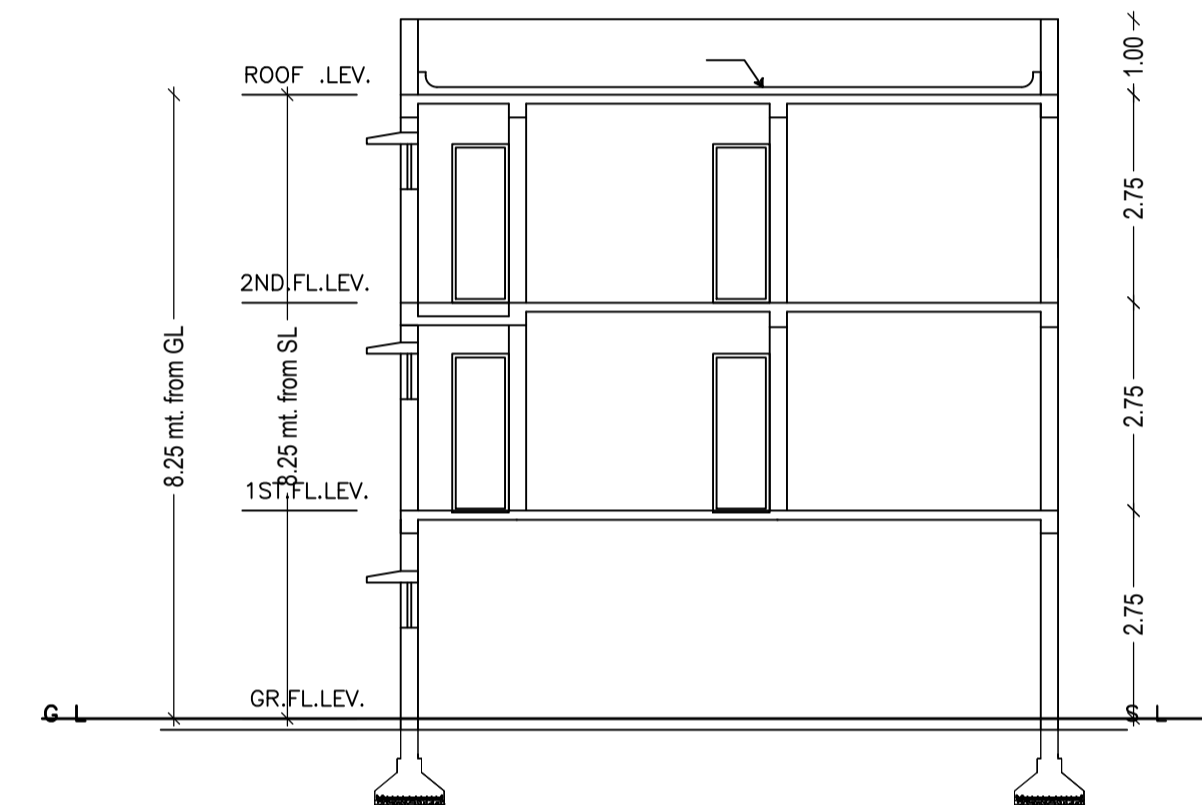

SECTION -Y-Y'
SCALE : 1:100

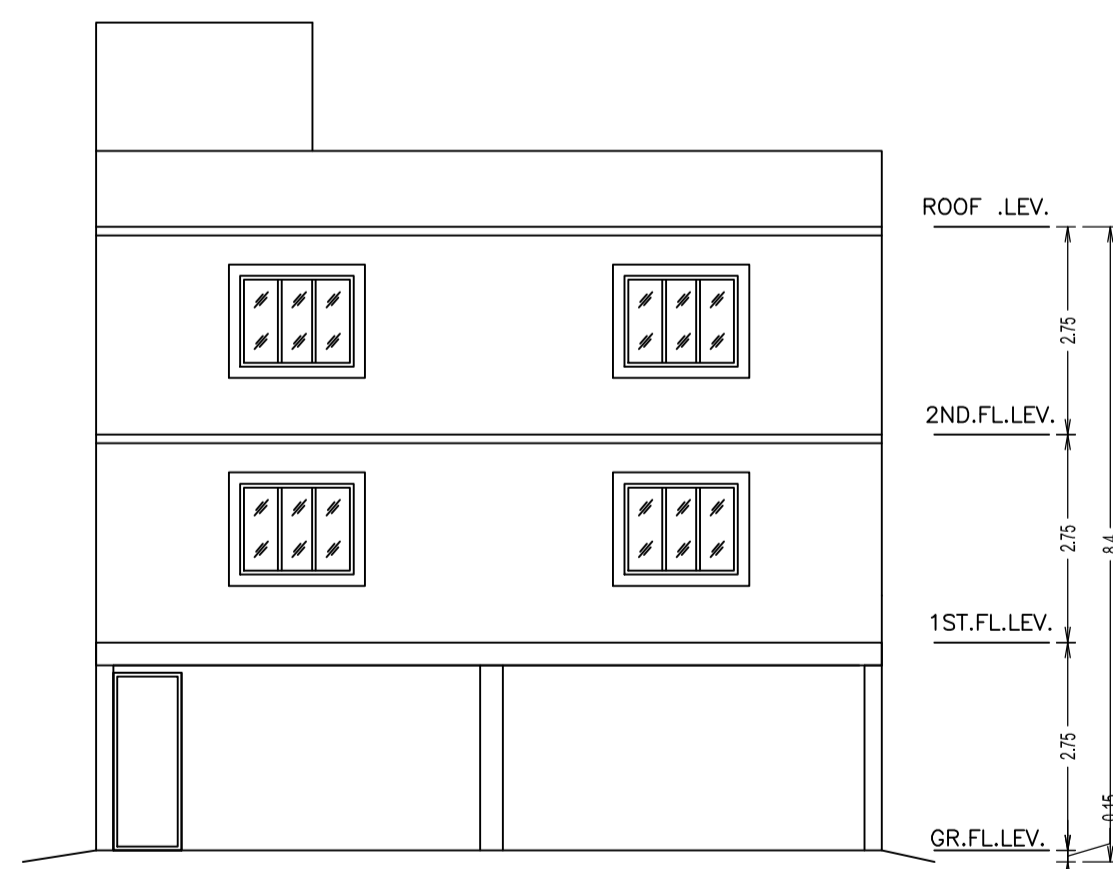
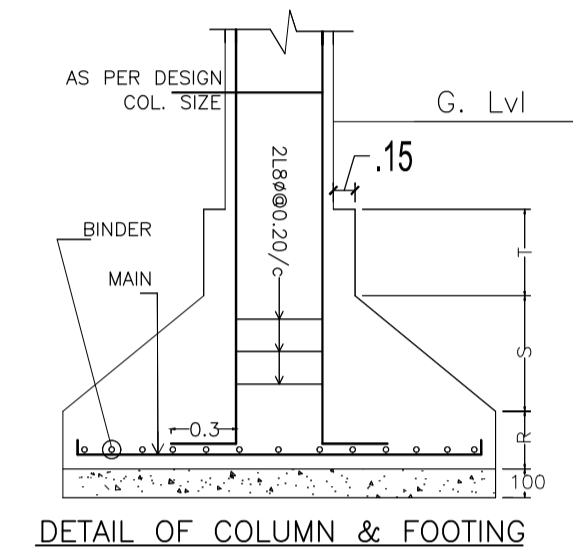

FRONT ELEVATION
SCALE : 1:100

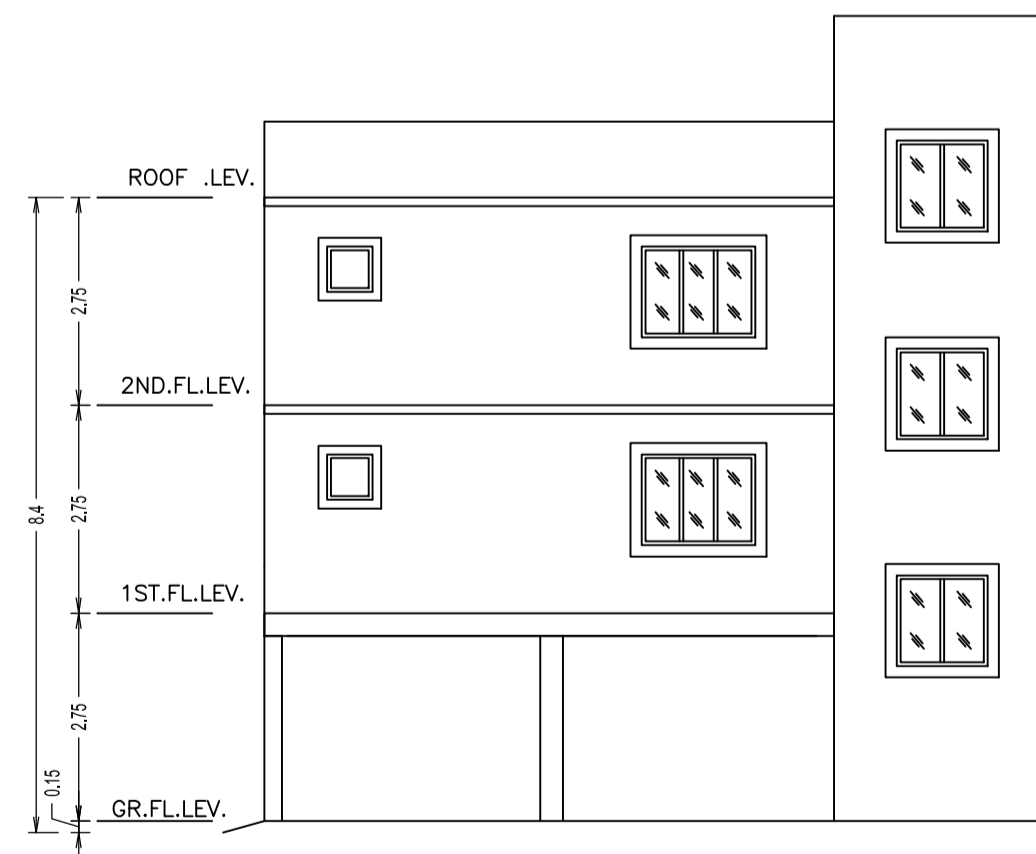

REAR ELEVATION
SCALE : 1:100

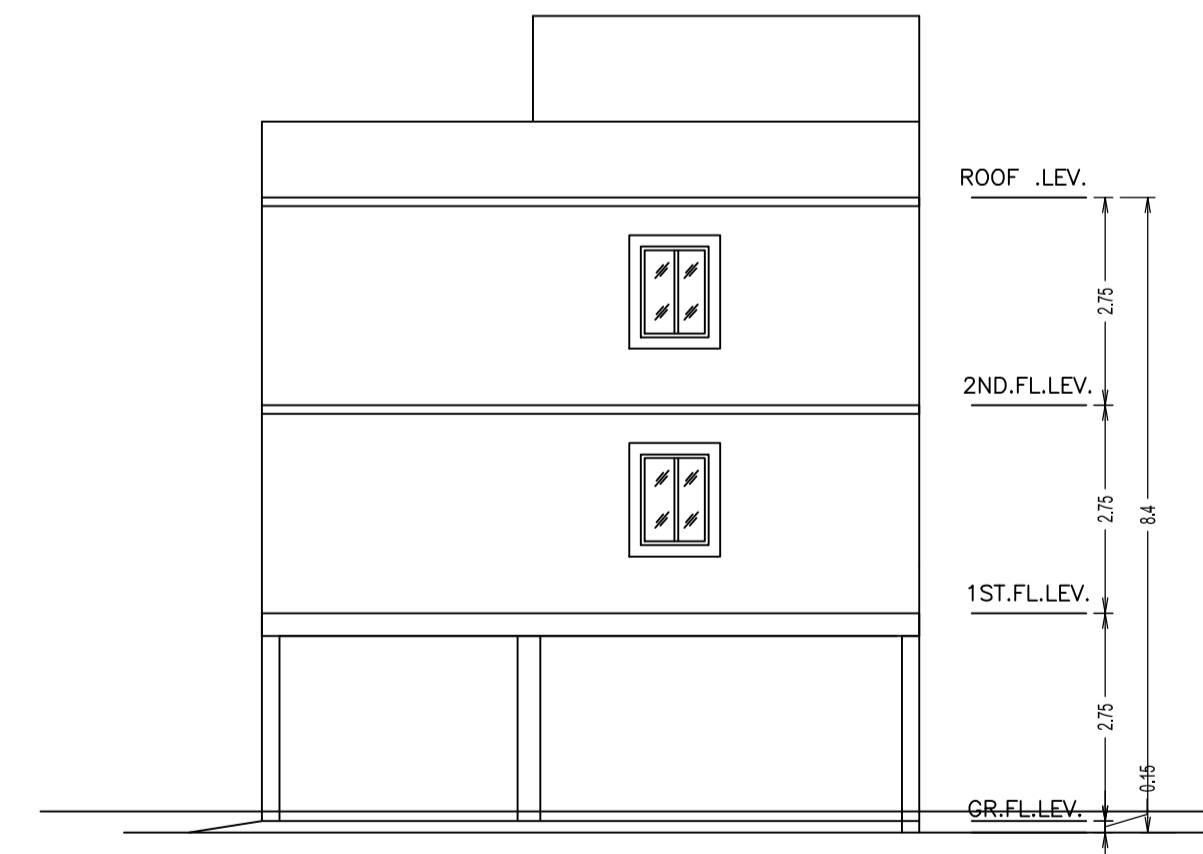

SIDE ELEVATION
SCALE : 1:100

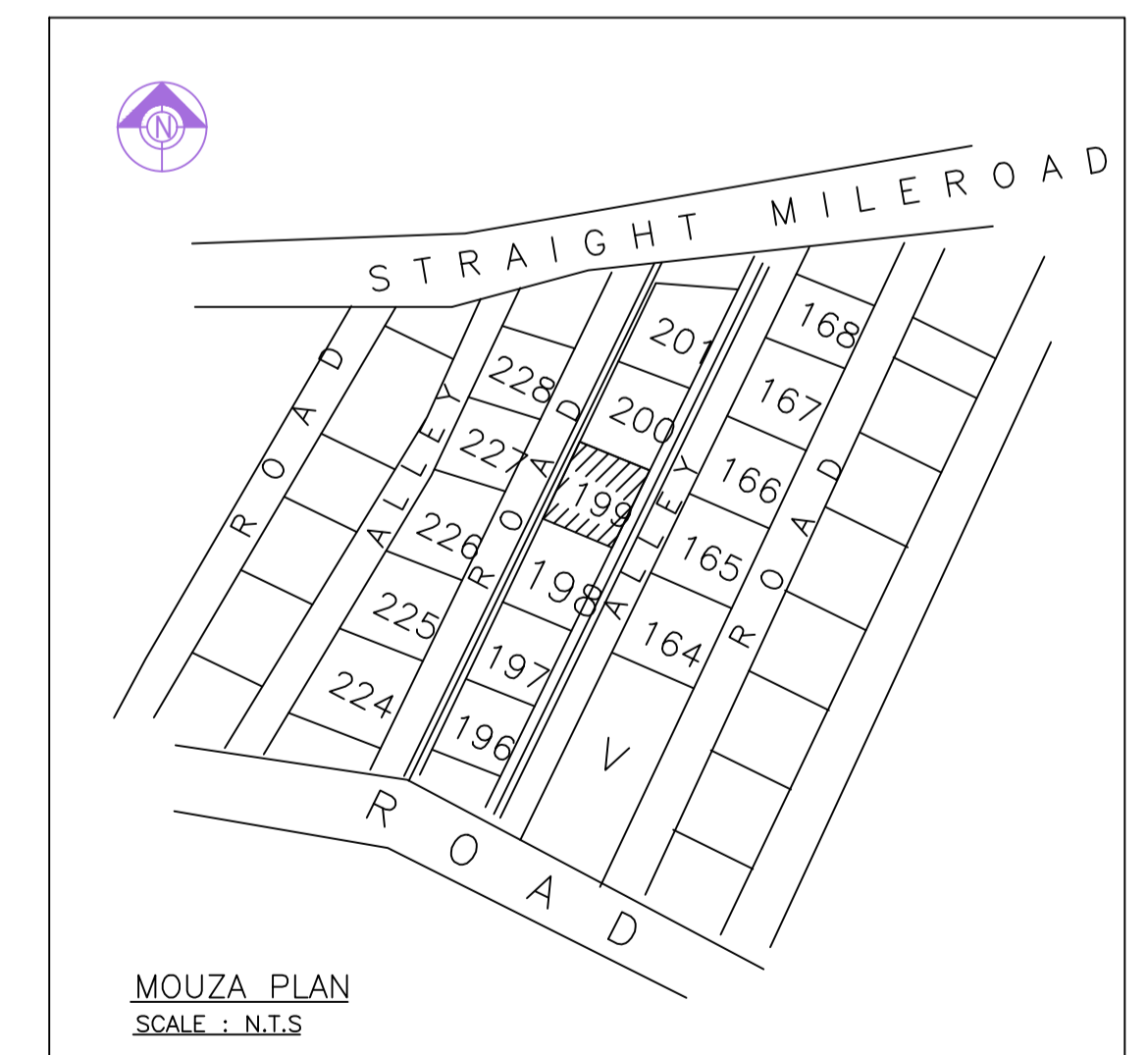

LTP NAME AND SIGNATURE	STRUCTURAL ENG'S NAME AND SIGNATURE	BUILDER NAME AND SIGNATURE
L K Suman JNAC/ENG/0006/2016		