

PLAN

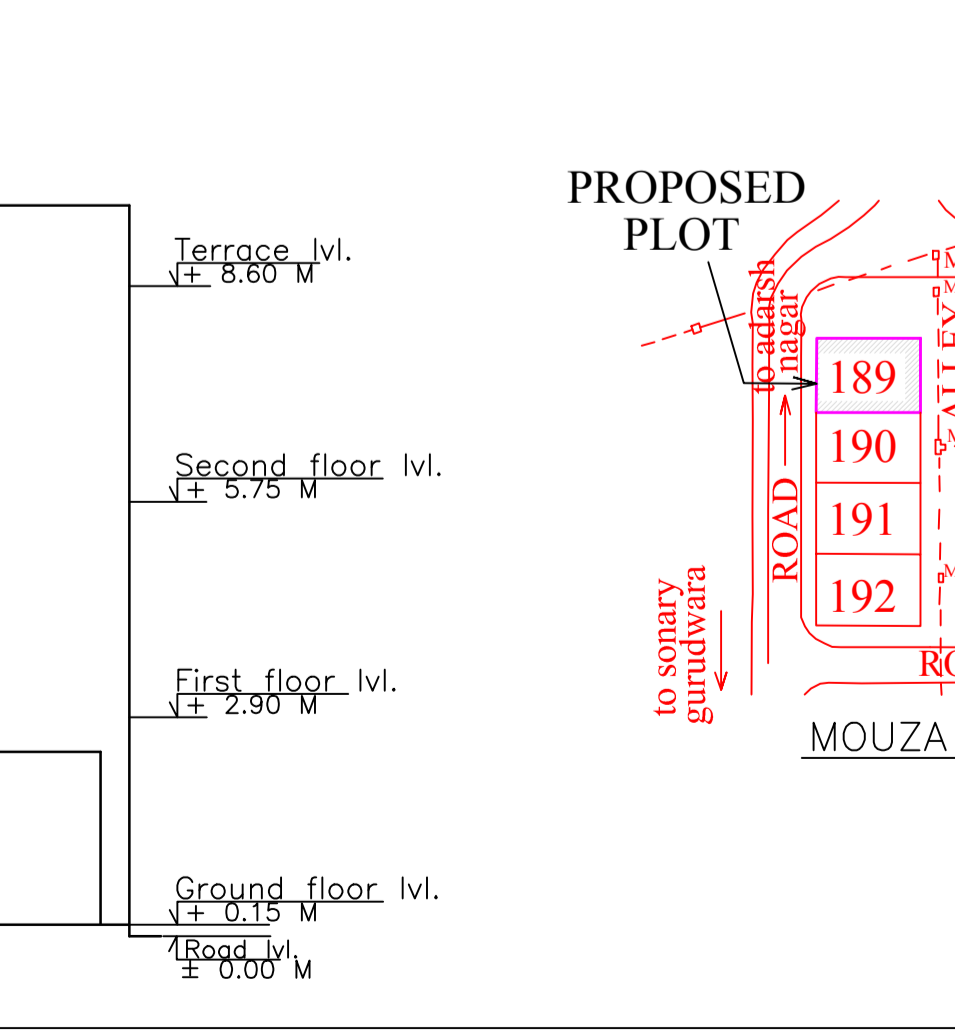
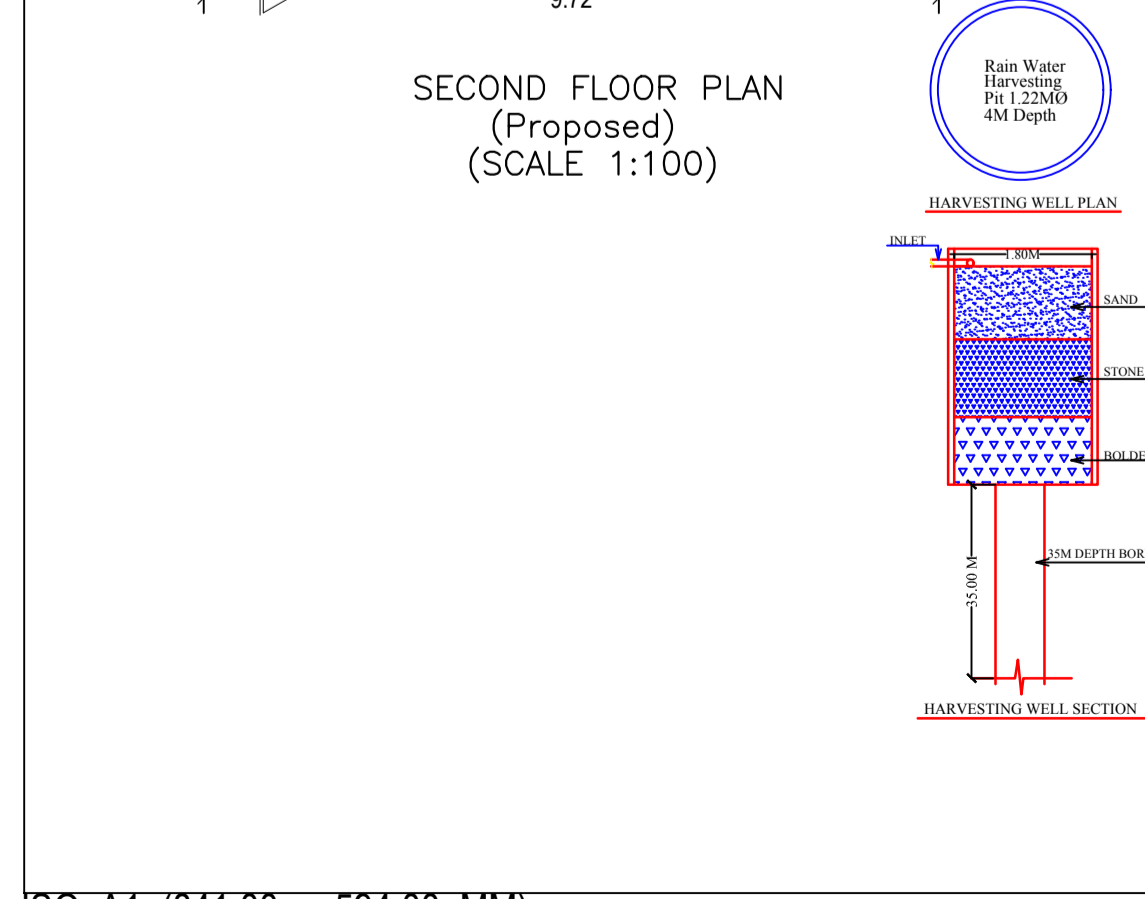
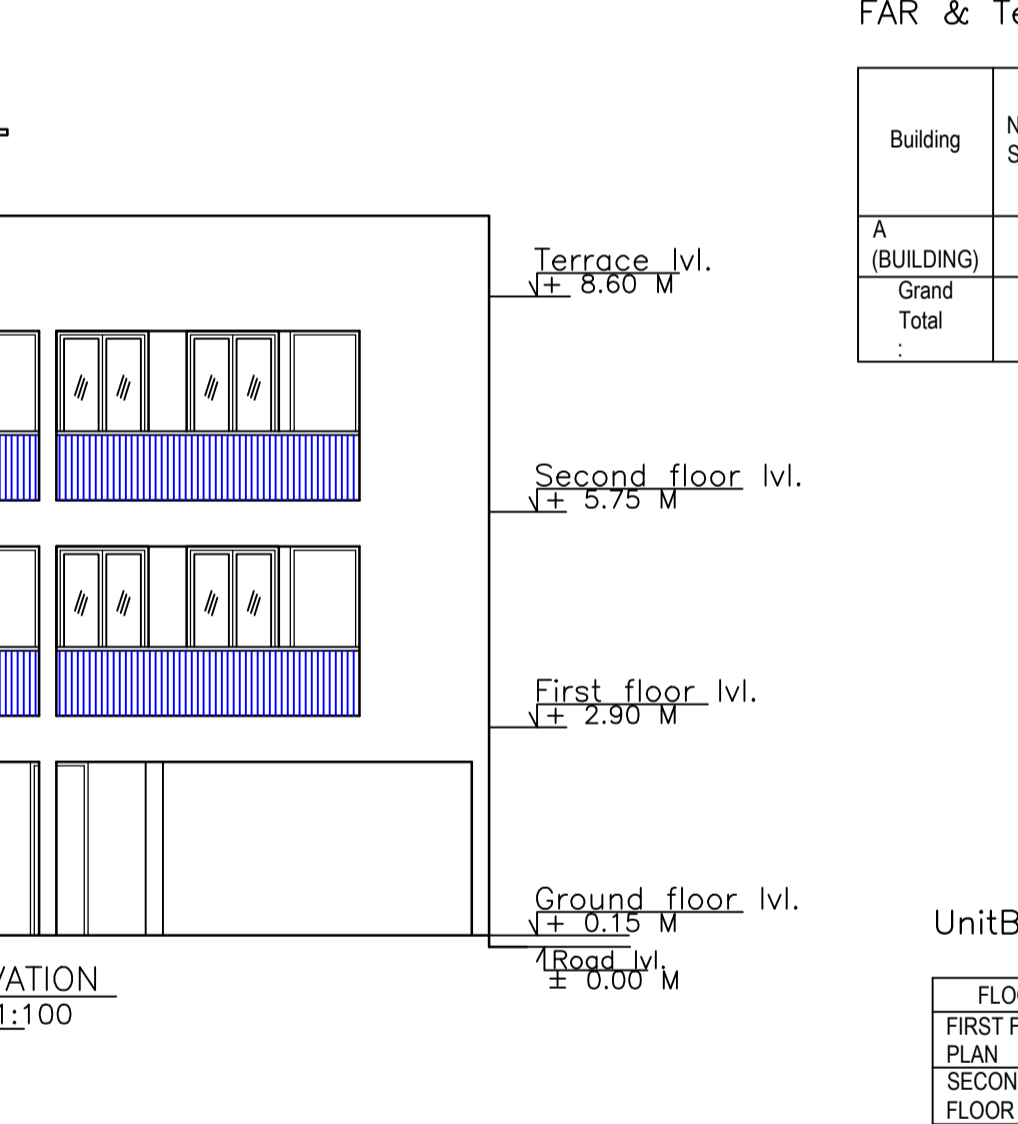
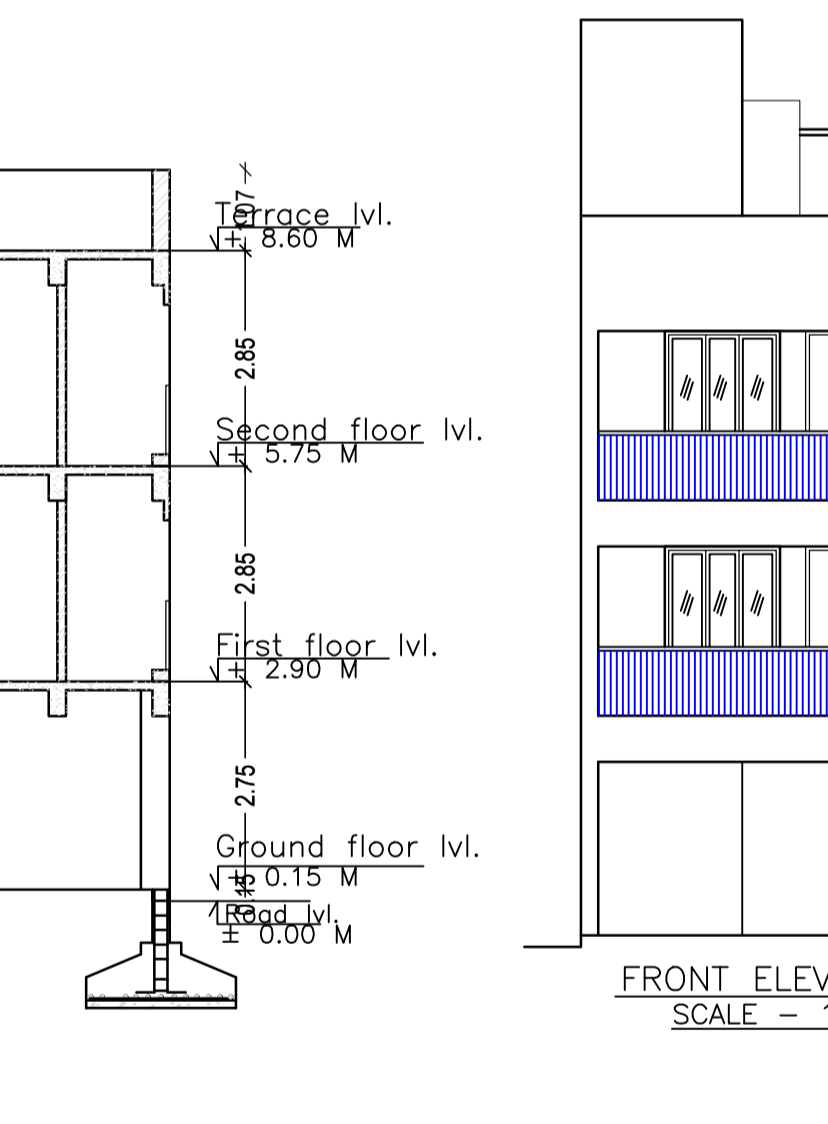
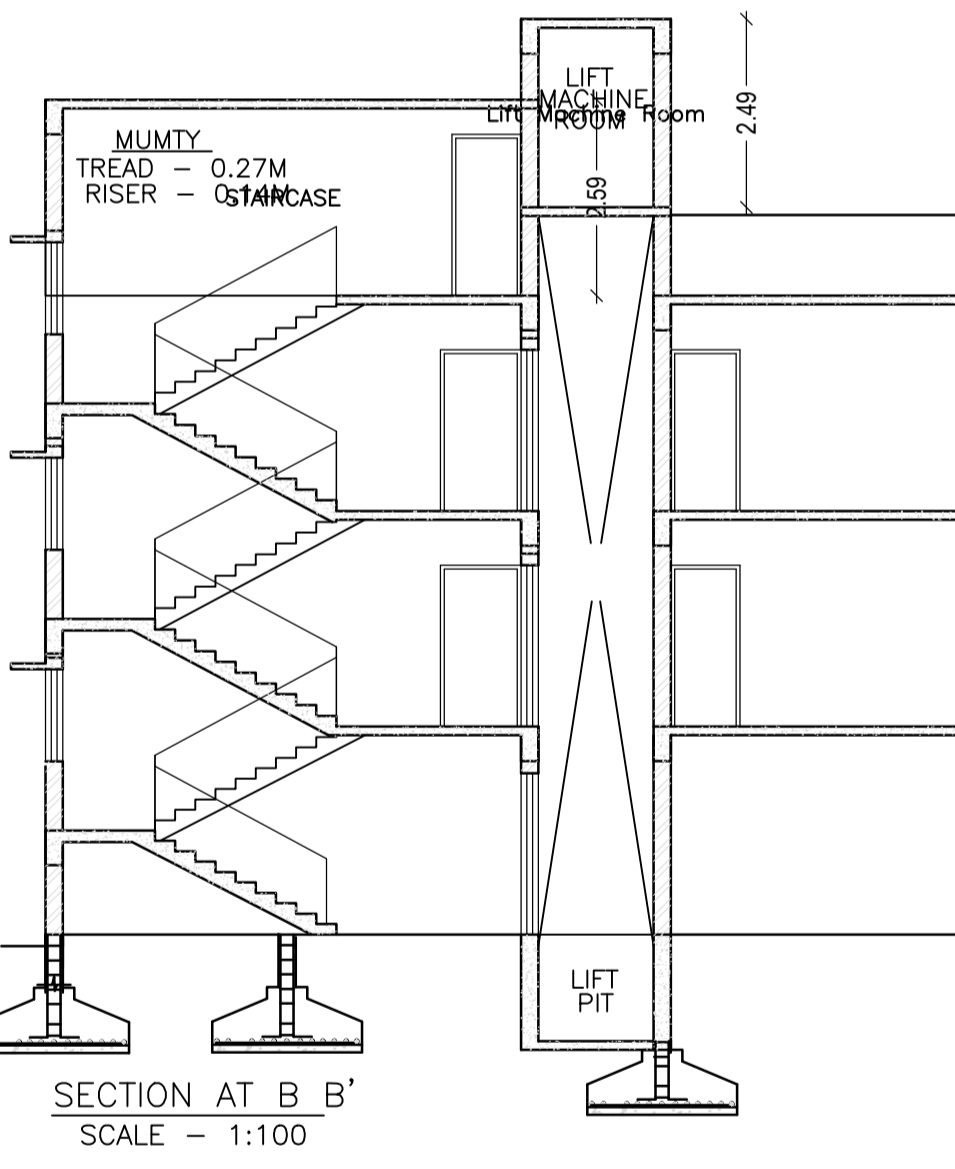
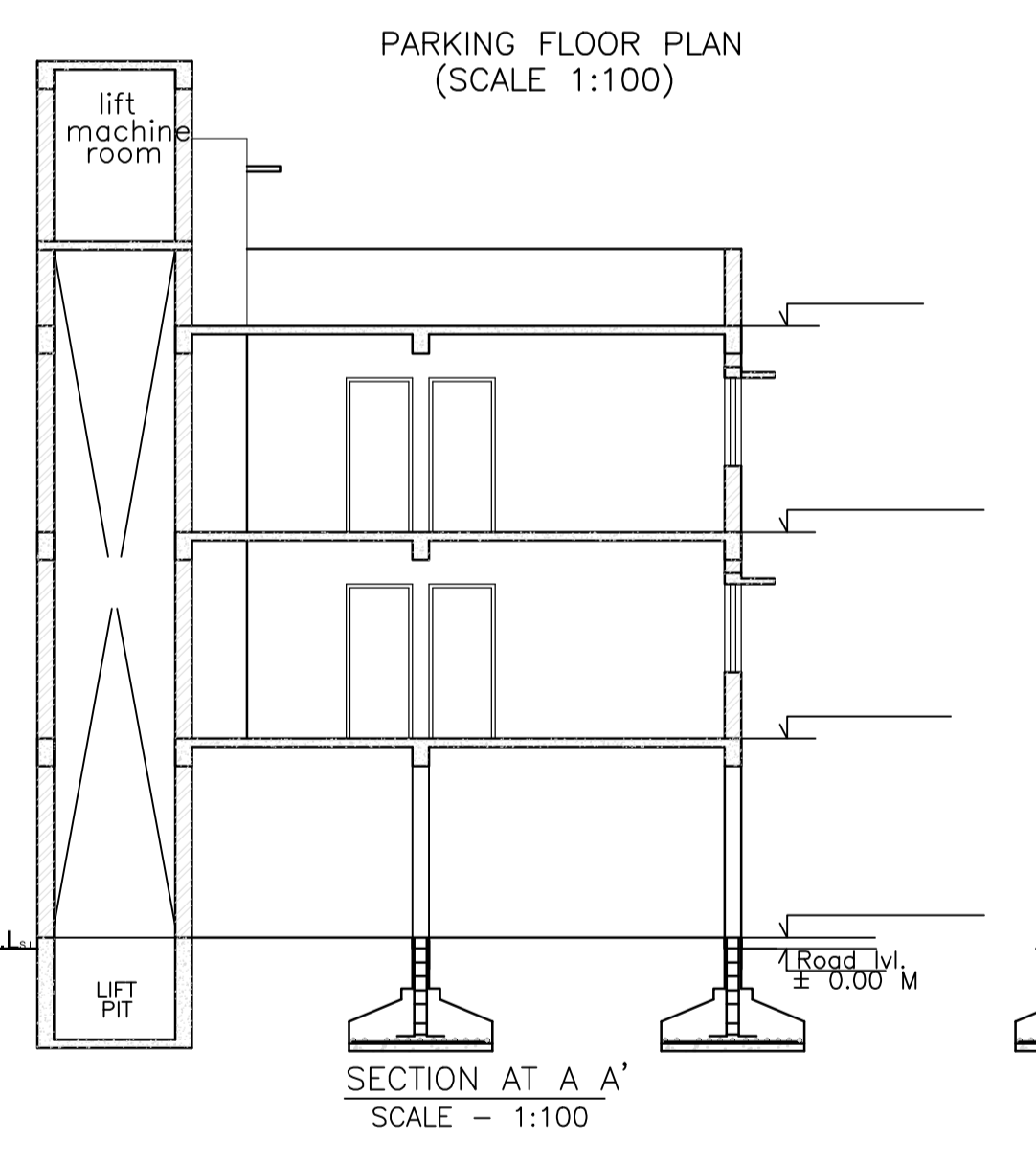
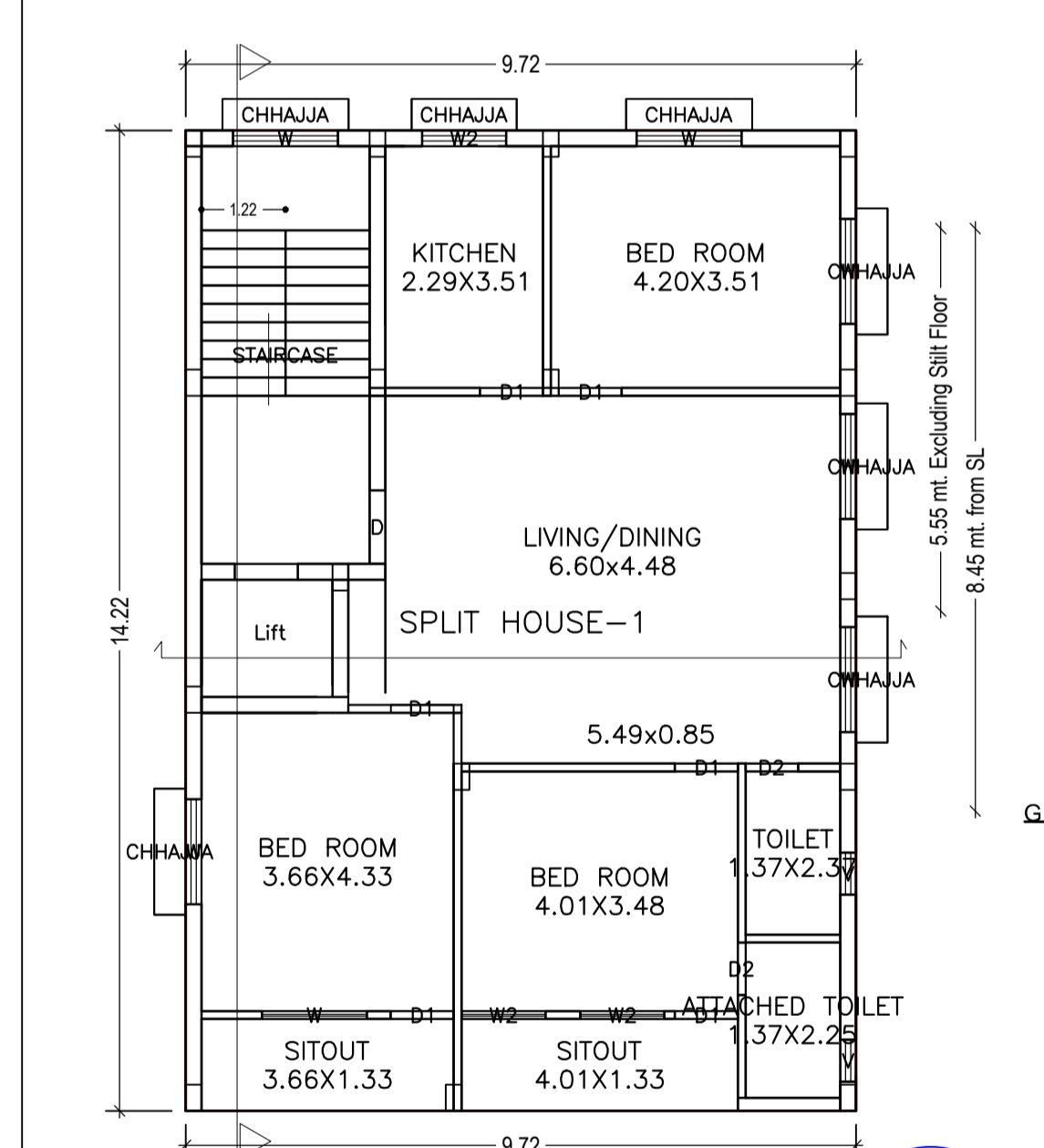

Buildingwise Floor FAR Details

| Floor Name | Building Name A (BUILDING) | | Total | |
|----------------|---------------------------------|----------------------------|---------------------------------------|-------------------------|
| | Proposed Built Up Area (Sq.mt.) | Proposed FAR Area (Sq.mt.) | Total Proposed Built Up Area (Sq.mt.) | Total FAR Area (Sq.mt.) |
| Parking Floor | 138.29 | 17.99 | 138.29 | 17.99 |
| First Floor | 138.29 | 135.06 | 138.29 | 135.06 |
| Second Floor | 138.29 | 135.06 | 138.29 | 135.06 |
| Terrace Floor | 0.00 | 0.00 | 0.00 | 0.00 |
| Total : | 414.87 | 288.11 | 414.87 | 288.11 |

FAR & Tenement Details (Table 4c-1)

| Building | No. of Same Bldg | Total Built Up Area (Sq.mt.) | Deductions (Area in Sq.mt.) | | | Proposed FAR Area (Sq.mt.) | Add Area In FAR (Sq.mt.) | Total FAR Area (Sq.mt.) | Total Consumed Additional FAR Area (Sq.mt.) | Tnmt (No.) |
|--------------------|------------------|------------------------------|-----------------------------|---------------|---------------|----------------------------|--------------------------|-------------------------|---|------------|
| | | | Lift | Accessory Use | Parking | | | | | |
| A (BUILDING) | 1 | 414.87 | 6.46 | 4.82 | 115.48 | 270.12 | 14.77 | 288.11 | 288.11 | 01 |
| Grand Total | 1 | 414.87 | 6.46 | 4.82 | 115.48 | 270.12 | 14.77 | 288.11 | 288.11 | 01 |

SCHEDULE OF DOOR:

| BUILDING NAME | NAME | LENGTH | HEIGHT | NOS |
|---------------|------|--------|--------|-----|
| A (BUILDING) | D2 | 0.76 | 2.10 | 04 |
| A (BUILDING) | D1 | 0.91 | 2.10 | 12 |
| A (BUILDING) | D | 1.07 | 2.10 | 02 |

SCHEDULE OF WINDOW/VENTILATION:

| BUILDING NAME | NAME | LENGTH | HEIGHT | NOS |
|---------------|------|--------|--------|-----|
| A (BUILDING) | V | 0.61 | 0.61 | 04 |
| A (BUILDING) | W2 | 1.22 | 1.20 | 06 |
| A (BUILDING) | W | 1.52 | 1.20 | 16 |

UnitBUA Table for Building :A (BUILDING)

| FLOOR | Name | UnitBUA Type | UnitBUA Area | Carpet Area | No. of Rooms | No. of Tenement |
|-------------------|---------------|--------------|---------------|---------------|--------------|-----------------|
| FIRST FLOOR PLAN | SPLIT HOUSE-1 | FLAT | 270.12 | 238.32 | 9 | 1 |
| SECOND FLOOR PLAN | SPLIT HOUSE-1 | FLAT | 0.00 | 0.00 | 9 | 0 |
| Total: | - | - | 270.12 | 238.32 | 18 | 1 |

Building :A (BUILDING)

| Floor Name | Total Built Up Area (Sq.mt.) | Deductions (Area in Sq.mt.) | | | Proposed FAR Area (Sq.mt.) | Add Area In FAR (Sq.mt.) | Total FAR Area (Sq.mt.) | Total Consumed Additional FAR Area (Sq.mt.) | Tnmt (No.) |
|----------------|------------------------------|-----------------------------|---------------|---------------|----------------------------|--------------------------|-------------------------|---|------------|
| | | Lift | Accessory Use | Parking | Resi. | Stair | | | |
| Parking Floor | 138.29 | 0.00 | 4.82 | 115.48 | 0.00 | 14.77 | 17.99 | 17.99 | 00 |
| First Floor | 138.29 | 3.23 | 0.00 | 0.00 | 135.06 | 0.00 | 135.06 | 135.06 | 01 |
| Second Floor | 138.29 | 3.23 | 0.00 | 0.00 | 135.06 | 0.00 | 135.06 | 135.06 | 00 |
| Terrace Floor | 0.00 | 0.00 | 0.00 | 0.00 | 0.00 | 0.00 | 0.00 | 0.00 | 00 |
| Total : | 414.87 | 6.46 | 4.82 | 115.48 | 270.12 | 14.77 | 288.11 | 288.11 | 01 |

Total Number of Same Buildings : 1

| LTP NAME AND SIGNATURE | STRUCTURAL ENG'S NAME AND SIGNATURE | BUILDER NAME AND SIGNATURE |
|-------------------------------------|-------------------------------------|----------------------------|
| SATISH KUMAR JNAC/DFTM/0004/2017 | | |